

+5V, Single Chip WAN Multi-Mode Serial Transceiver

- Interface Modes Supported:
 - ✓ RS-232 (v.28) ✓ X.21/RS-422 (v.11)
 - ✓ EIA-530 (v.10 & v.11) ✓ EIA-530A (v.10 & v.11)
 - ✓ RS-449 (v.10 & v.11) ✓ V.35 (v.35 & v.28)
- Software Selectable Protocols
- Highest Differential Transmission Rates available at over 20Mbps
- +5V Only Operation
- Seven (7) Drivers and Seven (7) Receivers
- Driver and Receiver Tri-state Control
- Internal Transceiver Termination Resistors for V.11 and V.35 Protocols
- Improved ESD Tolerance for Analog I/Os
- Compliant to NET1/2 and TBR2 Physical Layer Requirements
- Used in WAN Serial Ports in Routers Switches, DSU/CSU's and other Access Devices
- Available in 132-Lead Small Scale Ball Grid Array and 80-Lead MQFP

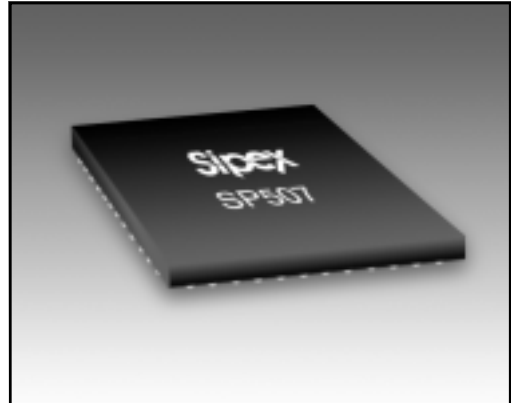

DESCRIPTION

The **SP507** is a monolithic IC that supports seven (7) popular serial interface standards for DTE/DCE connectivity. The seven (7) drivers and seven (7) receivers transmit and receive signals at over 20Mbps. The **SP507** requires no additional external components for compliant operation for all seven (7) modes of operation. All necessary termination is integrated within the **SP507** and is switchable when V.35 drivers, V.35 receivers, and V.11 receivers are used. The **SP507** can operate as either a DTE or DCE.

Additional features include a latch enable pin with the driver and receiver address decoder. Tri-state ability for the driver and receiver outputs is controlled by supplying a 3-bit word into the address decoder. Four (4) drivers and four (4) receivers in the **SP507** include separate enable pins for added convenience.

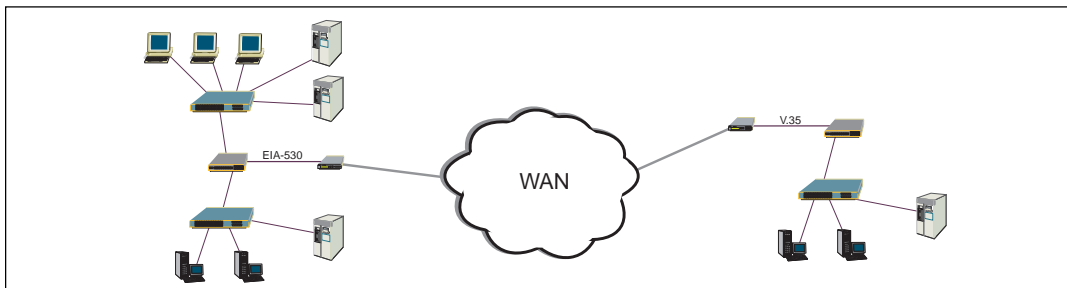

ABSOLUTE MAXIMUM RATINGS

These are stress ratings only and functional operation of the device at these ratings or any other above those indicated in the operation sections of the specifications below is not implied. Exposure to absolute maximum rating conditions for extended periods of time may affect reliability.

V_{CC}+7V

Input Voltages:

Logic.....-0.3V to ($V_{CC} + 0.5V$)

Drivers.....-0.3V to ($V_{CC} + 0.5V$)

Receivers..... $\pm 15.5V$

Output Voltages:

Logic.....-0.3V to ($V_{CC} + 0.5V$)

Drivers..... $\pm 15V$

Receivers.....-0.3V to ($V_{CC} + 0.5V$)

Storage Temperature.....-65°C to +150°C

Power Dissipation per package

80-pin QFP (derate 18.3mW/°C above +70°C)...1500mW

STORAGE CONSIDERATIONS

Due to the relatively large package size of the 80-pin quad flat-pack, storage in a low humidity environment is preferred. Large high density plastic packages are moisture sensitive and should be stored in Dry Vapor Barrier Bags. Prior to usage, the parts should remain bagged and stored below 40°C and 60%RH. If the parts are removed from the bag, they should be used within 48 hours or stored in an environment at or below 20%RH. If the above conditions cannot be followed, the parts should be baked for four hours at 125°C in order to remove moisture prior to soldering. Sipex ships the 80-pin QFP in Dry Vapor Barrier Bags with a humidity indicator card and desiccant pack. The humidity indicator should be below 30%RH.

SPECIFICATIONS

$T_A = +25^\circ\text{C}$ and $V_{CC} = +4.75V$ to $+5.25V$ unless otherwise noted.

| | MIN. | TYP. | MAX. | UNITS | CONDITIONS |
|-------------------------|-----------|------|-----------|------------------|----------------------------------|
| LOGIC INPUTS | | | | | |
| V_{IL} | | | 0.8 | Volts | |
| V_{IH} | 2.0 | | | Volts | |
| LOGIC OUTPUTS | | | | | |
| V_{OL} | | | 0.4 | Volts | $I_{OUT} = -3.2\text{mA}$ |
| V_{OH} | 2.4 | | | Volts | $I_{OUT} = 1.0\text{mA}$ |
| V.28 DRIVER | | | | | |
| DC Parameters | | | | | |
| Outputs | | | | | |
| Open Circuit Voltage | | | ± 15 | Volts | per Figure 1 |
| Loaded Voltage | ± 5.0 | | ± 15 | Volts | per Figure 2 |
| Short-Circuit Current | | | ± 100 | mA | per Figure 4 |
| Power-Off Impedance | 300 | | | Ω | per Figure 5 |
| AC Parameters | | | | | |
| Outputs | | | | | |
| Transition Time | | | 1.5 | μs | per Figure 6; +3V to -3V |
| Instantaneous Slew Rate | | | 30 | V/ μs | per Figure 3 |
| Propagation Delay | | | | | |
| t_{PHL} | 0.5 | 1 | 5 | μs | |
| t_{PLH} | 0.5 | 1 | 5 | μs | |
| Max. Transmission Rate | 120 | 230 | | kbps | |
| V.28 RECEIVER | | | | | |
| DC Parameters | | | | | |
| Inputs | | | | | |
| Input Impedance | 3 | | 7 | k Ω | per Figure 7 |
| Open-Circuit Bias | | | +2.0 | Volts | per Figure 8 |
| HIGH Threshold | | 1.7 | 3.0 | Volts | |
| LOW Threshold | 0.8 | 1.2 | | Volts | |
| AC Parameters | | | | | |
| Propagation Delay | | | | | |
| t_{PHL} | 50 | 100 | 500 | ns | $V_{CC} = +5V$ for AC parameters |
| t_{PLH} | 50 | 100 | 500 | ns | |

SPECIFICATIONS

T_A = +25°C and V_{CC} = +4.75V to +5.25V unless otherwise noted.

| | MIN. | TYP. | MAX. | UNITS | CONDITIONS |
|---------------------------------------------------------------------------------------------------------------------------------------------------------------------------------------------------------------------------------------------------------------------------------------------------------------------------------------------------|----------------------------|------|-------------------------------------------------------------------------------------------|------------------------------------------------------------------------------|-----------------------------------------------------------------------------------------------------------------------------------------------------------------------------------------------------------------------------------------------------------------------------------------------------------------------------------------------------------------------------------------------------------------|
| V.28 RECEIVER (continued) AC Parameters (cont.) Max. Transmission Rate | 120 | 230 | | kbps | |
| V.10 DRIVER DC Parameters Outputs Open Circuit Voltage Test-Terminated Voltage Short-Circuit Current Power-Off Current AC Parameters Outputs Transition Time Propagation Delay t _{PHL} t _{PLH} Max. Transmission Rate | ±4.0 0.9V _{OC} | | ±6.0 ±150 ±100 200 50 50 120 | Volts Volts mA μA ns ns kbps | per Figure 9 per Figure 10 per Figure 11 per Figure 12 V_{CC} = +5V for AC parameters per Figure 13; 10% to 90% |
| V.10 RECEIVER DC Parameters Inputs Input Current Input Impedance Sensitivity AC Parameters Propagation Delay t _{PHL} t _{PLH} Max. Transmission Rate | -3.25 4 | | +3.25 ±0.3 50 50 120 | mA kΩ Volts ns ns kbps | per Figures 14 and 15 V_{CC} = +5V for AC parameters |
| V.11 DRIVER DC Parameters Outputs Open Circuit Voltage Test Terminated Voltage Balance Offset Short-Circuit Current Power-Off Current AC Parameters Outputs Transition Time Propagation Delay t _{PHL} t _{PLH} Differential Skew Max. Transmission Rate | ±2.0 0.5V _{OC} | | ±5.0 0.67V _{OC} ±0.4 +3.0 ±150 ±100 20 50 50 10 20 | Volts Volts Volts Volts mA μA ns ns ns ns Mbps | per Figure 16 per Figure 17 per Figure 17 per Figure 17 per Figure 18 per Figure 19 V_{CC} = +5V for AC parameters per Figures 21 and 36; 10% to 90% per Figures 33 and 36, C _L = 50pF per Figures 33 and 36, C _L = 50pF per Figures 33 and 36, C _L = 50pF per Figure 33, C _L = 50pF f _{IN} = 10MHz |
| V.11 RECEIVER DC Parameters Inputs Common Mode Range Sensitivity | -7 | | +7 ±0.3 | Volts Volts | |

SPECIFICATIONS

T_A = +25°C and V_{CC} = +4.75V to +5.25V unless otherwise noted.

| | MIN. | TYP. | MAX. | UNITS | CONDITIONS |
|-------------------------------------|-------|------|--------|-------|----------------------------------------------------------------------|
| V.11 RECEIVER (continued) | | | | | |
| DC Parameters (cont.) | | | | | |
| Input Current | -3.25 | | ±3.25 | mA | per Figure 20 and 22 |
| Current w/ 100Ω Termination | | | ±60.75 | mA | per Figure 23 and 24 |
| Input Impedance | 4 | | | kΩ | |
| AC Parameters | | | | | |
| Propagation Delay | | | | | V_{CC} = +5V for AC parameters |
| t _{PHL} | 30 | 65 | 85 | ns | per Figures 33 and 38; C _L = 50pF |
| t _{PLH} | 30 | 65 | 85 | ns | per Figures 33 and 38; C _L = 50pF |
| Differential Skew | | 10 | | ns | per Figure 33; C _L = 50pF |
| Max.Transmission Rate | 20 | | | Mbps | per Figure 33; C _L = 50pF f _{IN} = 10MHz |
| V.35 DRIVER | | | | | |
| DC Parameters | | | | | |
| Outputs | | | | | |
| Open Circuit Voltage | | | ±1.20 | Volts | per Figure 16 |
| Test Terminated Voltage | ±0.44 | | ±0.66 | Volts | per Figure 25 |
| Offset | | | ±0.6 | Volts | per Figure 25 |
| Source Impedance | 50 | | 150 | Ω | per Figure 27; Z _S = V ₂ /V ₁ x 50Ω |
| Short-Circuit Impedance | 135 | | 165 | Ω | per Figure 28 |
| AC Parameters | | | | | |
| Outputs | | | | | |
| Transition Time | | 30 | 40 | ns | per Figure 29; 10% to 90% |
| Propagation Delay | | | | | |
| t _{PHL} | 50 | 70 | 90 | ns | per Figures 33 and 36; C _L = 20pF |
| t _{PLH} | 50 | 70 | 90 | ns | per Figures 33 and 36; C _L = 20pF |
| Differential Skew | | 7 | 10 | ns | per Figures 33 and 36; C _L = 20pF |
| Max.Transmission Rate | 20 | | | Mbps | per Figure 33; C _L = 20pF f _{IN} = 10MHz |
| V.35 RECEIVER | | | | | |
| DC Parameters | | | | | |
| Inputs | | | | | |
| Sensitivity | | ±80 | | mV | |
| Source Impedance | 90 | | 110 | Ω | per Figure 30; Z _S = V ₂ /V ₁ x 50Ω |
| Short-Circuit Impedance | 135 | | 165 | Ω | per Figure 31 |
| AC Parameters | | | | | |
| Propagation Delay | | | | | V_{CC} = +5V for AC parameters |
| t _{PHL} | 30 | 75 | 90 | ns | per Figures 33 and 38; C _L = 20pF |
| t _{PLH} | 30 | 75 | 90 | ns | per Figures 33 and 38; C _L = 20pF |
| Differential Skew | | 10 | | ns | per Figure 33; C _L = 20pF |
| Max.Transmission Rate | 20 | | | Mbps | per Figure 33; C _L = 20pF f _{IN} = 10MHz |
| TRANSCEIVER LEAKAGE CURRENTS | | | | | |
| Driver Output 3-State Current | | 500 | | μA | per Figure 32; Drivers disabled |
| Rcvr Output 3-State Current | | 1 | 10 | μA | Mx = 111, 0.4V ≤ V _O ≤ 2.4V |

OTHER AC CHARACTERISTICS

$T_A = +25^\circ\text{C}$ and $V_{CC} = +5.0\text{V}$ unless otherwise noted.

| PARAMETER | MIN. | TYP. | MAX. | UNITS | CONDITIONS |
|-------------------------------------------------------------------|------|------|------|---------------|---------------------------------------------------|
| DRIVER DELAY TIME BETWEEN ACTIVE MODE AND TRI-STATE MODE | | | | | |
| RS-232/V.28 | | | | | |
| t_{PZL} ; Tri-state to Output LOW | | 0.70 | 5.0 | μs | $C_L = 100\text{pF}$, Fig. 34 & 40; S_1 closed |
| t_{PZH} ; Tri-state to Output HIGH | | 0.40 | 2.0 | μs | $C_L = 100\text{pF}$, Fig. 34 & 40; S_2 closed |
| t_{PLZ} ; Output LOW to Tri-state | | 0.20 | 2.0 | μs | $C_L = 100\text{pF}$, Fig. 34 & 40; S_1 closed |
| t_{PHZ} ; Output HIGH to Tri-state | | 0.40 | 2.0 | μs | $C_L = 100\text{pF}$, Fig. 34 & 40; S_2 closed |
| RS-423/V.10 | | | | | |
| t_{PZL} ; Tri-state to Output LOW | | 0.15 | 2.0 | μs | $C_L = 100\text{pF}$, Fig. 34 & 40; S_1 closed |
| t_{PZH} ; Tri-state to Output HIGH | | 0.20 | 2.0 | μs | $C_L = 100\text{pF}$, Fig. 34 & 40; S_2 closed |
| t_{PLZ} ; Output LOW to Tri-state | | 0.20 | 2.0 | μs | $C_L = 100\text{pF}$, Fig. 34 & 40; S_1 closed |
| t_{PHZ} ; Output HIGH to Tri-state | | 0.15 | 2.0 | μs | $C_L = 100\text{pF}$, Fig. 34 & 40; S_2 closed |
| RS-422/V.11 | | | | | |
| t_{PZL} ; Tri-state to Output LOW | | 2.80 | 10.0 | μs | $C_L = 100\text{pF}$, Fig. 34 & 37; S_1 closed |
| t_{PZH} ; Tri-state to Output HIGH | | 0.10 | 2.0 | μs | $C_L = 100\text{pF}$, Fig. 34 & 37; S_2 closed |
| t_{PLZ} ; Output LOW to Tri-state | | 0.10 | 2.0 | μs | $C_L = 15\text{pF}$, Fig. 34 & 37; S_1 closed |
| t_{PHZ} ; Output HIGH to Tri-state | | 0.10 | 2.0 | μs | $C_L = 15\text{pF}$, Fig. 34 & 37; S_2 closed |
| V.35 | | | | | |
| t_{PZL} ; Tri-state to Output LOW | | 2.60 | 10.0 | μs | $C_L = 100\text{pF}$, Fig. 34 & 37; S_1 closed |
| t_{PZH} ; Tri-state to Output HIGH | | 0.10 | 2.0 | μs | $C_L = 100\text{pF}$, Fig. 34 & 37; S_2 closed |
| t_{PLZ} ; Output LOW to Tri-state | | 0.10 | 2.0 | μs | $C_L = 15\text{pF}$, Fig. 34 & 37; S_1 closed |
| t_{PHZ} ; Output HIGH to Tri-state | | 0.15 | 2.0 | μs | $C_L = 15\text{pF}$, Fig. 34 & 37; S_2 closed |
| RECEIVER DELAY TIME BETWEEN ACTIVE MODE AND TRI-STATE MODE | | | | | |
| RS-232/V.28 | | | | | |
| t_{PZL} ; Tri-state to Output LOW | | 0.12 | 2.0 | μs | $C_L = 100\text{pF}$, Fig. 35 & 38; S_1 closed |
| t_{PZH} ; Tri-state to Output HIGH | | 0.10 | 2.0 | μs | $C_L = 100\text{pF}$, Fig. 35 & 38; S_2 closed |
| t_{PLZ} ; Output LOW to Tri-state | | 0.10 | 2.0 | μs | $C_L = 100\text{pF}$, Fig. 35 & 38; S_1 closed |
| t_{PHZ} ; Output HIGH to Tri-state | | 0.10 | 2.0 | μs | $C_L = 100\text{pF}$, Fig. 35 & 38; S_2 closed |
| RS-423/V.10 | | | | | |
| t_{PZL} ; Tri-state to Output LOW | | 0.10 | 2.0 | μs | $C_L = 100\text{pF}$, Fig. 35 & 38; S_1 closed |
| t_{PZH} ; Tri-state to Output HIGH | | 0.10 | 2.0 | μs | $C_L = 100\text{pF}$, Fig. 35 & 38; S_2 closed |
| t_{PLZ} ; Output LOW to Tri-state | | 0.10 | 2.0 | μs | $C_L = 100\text{pF}$, Fig. 35 & 38; S_1 closed |
| t_{PHZ} ; Output HIGH to Tri-state | | 0.10 | 2.0 | μs | $C_L = 100\text{pF}$, Fig. 35 & 38; S_2 closed |

OTHER AC CHARACTERISTICS (Continued)

T_A = +25°C and V_{CC} = +5.0V unless otherwise noted.

| PARAMETER | MIN. | TYP. | MAX. | UNITS | CONDITIONS |
|-----------------------------------------------------------------|------|------|------|-------|---------------------------------------------------------------------------------|
| RS-422/V.11 | | | | | |
| t _{PZL} ; Tri-state to Output LOW | | 0.10 | 2.0 | μs | C _L = 100pF, Fig. 35 & 39; S ₁ closed |
| t _{PZH} ; Tri-state to Output HIGH | | 0.10 | 2.0 | μs | C _L = 100pF, Fig. 35 & 39; S ₂ closed |
| t _{PLZ} ; Output LOW to Tri-state | | 0.10 | 2.0 | μs | C _L = 15pF, Fig. 35 & 39; S ₁ closed |
| t _{PHZ} ; Output HIGH to Tri-state | | 0.10 | 2.0 | μs | C _L = 15pF, Fig. 35 & 39; S ₂ closed |
| V.35 | | | | | |
| t _{PZL} ; Tri-state to Output LOW | | 0.10 | 2.0 | μs | C _L = 100pF, Fig. 35 & 39; S ₁ closed |
| t _{PZH} ; Tri-state to Output HIGH | | 0.10 | 2.0 | μs | C _L = 100pF, Fig. 35 & 39; S ₂ closed |
| t _{PLZ} ; Output LOW to Tri-state | | 0.10 | 2.0 | μs | C _L = 15pF, Fig. 35 & 39; S ₁ closed |
| t _{PHZ} ; Output HIGH to Tri-state | | 0.10 | 2.0 | μs | C _L = 15pF, Fig. 35 & 39; S ₂ closed |
| TRANSCEIVER TO TRANSCEIVER SKEW (per Figures 33, 36, 38) | | | | | |
| V.28 Driver | | 100 | | ns | [(t _{phi}) _{Tx1} - (t _{phi}) _{Tx6,7}] |
| | | 100 | | ns | [(t _{phi}) _{Tx1} - (t _{phi}) _{Tx6,7}] |
| V.28 Receiver | | 20 | | ns | [(t _{phi}) _{Rx1} - (t _{phi}) _{Rx2,7}] |
| | | 20 | | ns | [(t _{phi}) _{Rx1} - (t _{phi}) _{Rx2,7}] |
| V.11 Driver | | 2 | | ns | [(t _{phi}) _{Tx1} - (t _{phi}) _{Tx6,7}] |
| | | 2 | | ns | [(t _{phi}) _{Tx1} - (t _{phi}) _{Tx6,7}] |
| V.11 Receiver | | 3 | | ns | [(t _{phi}) _{Rx1} - (t _{phi}) _{Rx2,7}] |
| | | 3 | | ns | [(t _{phi}) _{Rx1} - (t _{phi}) _{Rx2,7}] |
| V.10 Driver | | 5 | | ns | [(t _{phi}) _{Tx2} - (t _{phi}) _{Tx3,4,5}] |
| | | 5 | | ns | [(t _{phi}) _{Tx2} - (t _{phi}) _{Tx3,4,5}] |
| V.10 Receiver | | 5 | | ns | [(t _{phi}) _{Rx2} - (t _{phi}) _{Rx3,4,5}] |
| | | 5 | | ns | [(t _{phi}) _{Rx2} - (t _{phi}) _{Rx3,4,5}] |
| V.35 Driver | | 4 | | ns | [(t _{phi}) _{Tx1} - (t _{phi}) _{Tx6,7}] |
| | | 4 | | ns | [(t _{phi}) _{Tx1} - (t _{phi}) _{Tx6,7}] |
| V.35 Receiver | | 6 | | ns | [(t _{phi}) _{Rx1} - (t _{phi}) _{Rx2,7}] |
| | | 6 | | ns | [(t _{phi}) _{Rx1} - (t _{phi}) _{Rx2,7}] |

POWER REQUIREMENTS

| PARAMETER | MIN. | TYP. | MAX. | UNITS | CONDITIONS |
|----------------------------------------------------------------------------------------------------|------|-------------------------------|------|----------------------------|--------------------------------------------------------------------------------------------------------------------------------------------------------------------------------------------------------------------------------------------------------------------------------------------------------------|
| V _{CC} | 4.75 | 5.00 | 5.25 | Volts | |
| I _{CC} (No Mode Selected) (V.28/RS-232) (V.11/X.21) (EIA-530 & RS-449) (V.35) | | 30 65 175 250 100 | | mA mA mA mA mA | All I _{CC} values are with V _{CC} = +5V f _{IN} = 120kbps; Drivers active & loaded. f _{IN} = 10Mbps; Drivers active & loaded. f _{IN} = 10Mbps; Drivers active & loaded. V.35 @ f _{IN} = 10Mbps, V.28 @ 120kbps; Drivers active & loaded. |

TEST CIRCUITS

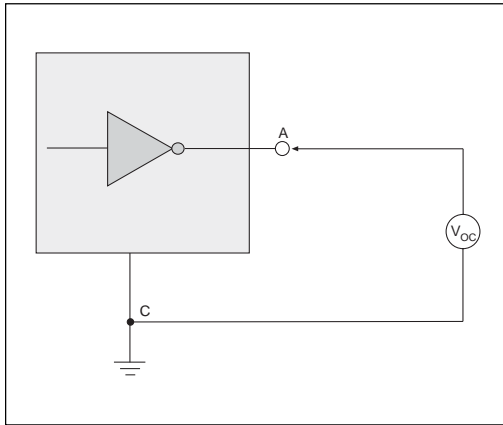

Figure 1. V.28 Driver Output Open Circuit Voltage

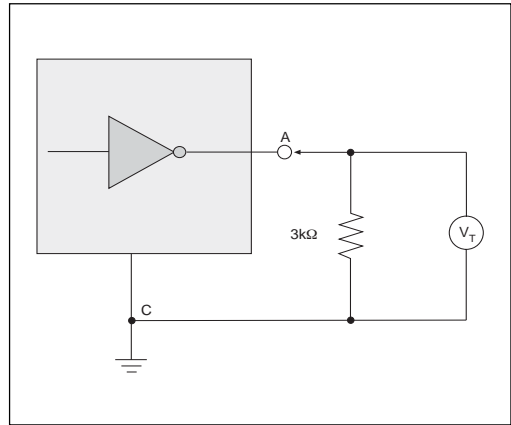

Figure 2. V.28 Driver Output Loaded Voltage

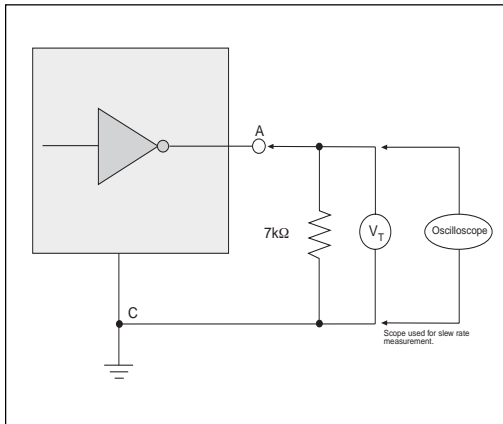

Figure 3. V.28 Driver Output Slew Rate

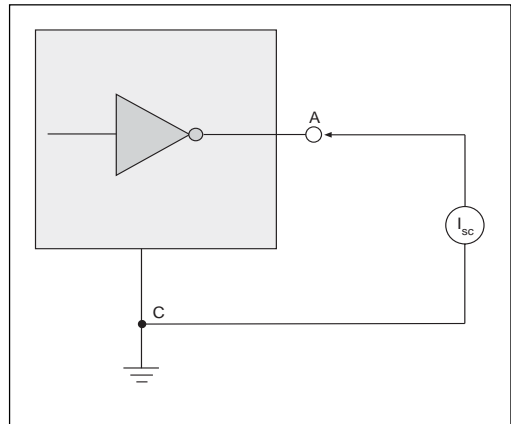

Figure 4. V.28 Driver Output Short-Circuit Current

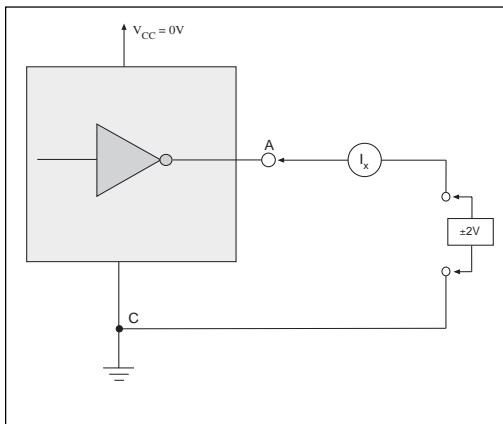

Figure 5. V.28 Driver Output Power-Off Impedance

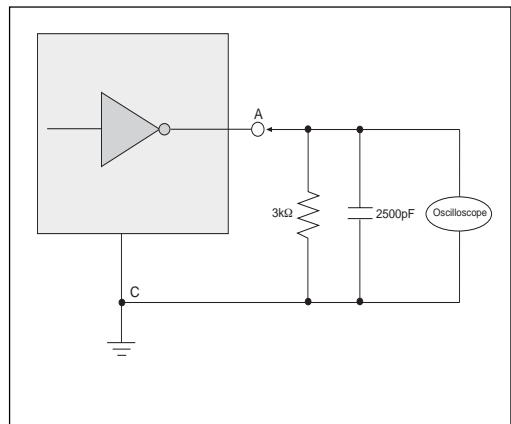

Figure 6. V.28 Driver Output Rise/Fall Times

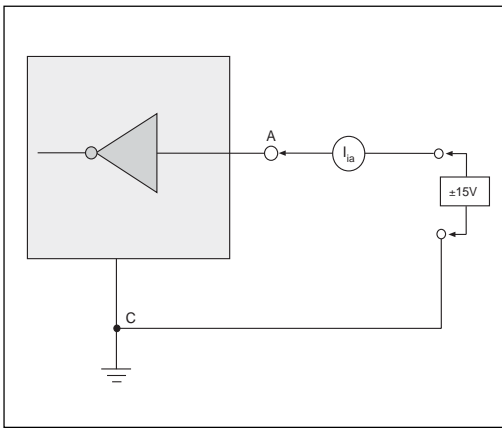

Figure 7. V.28 Receiver Input Impedance

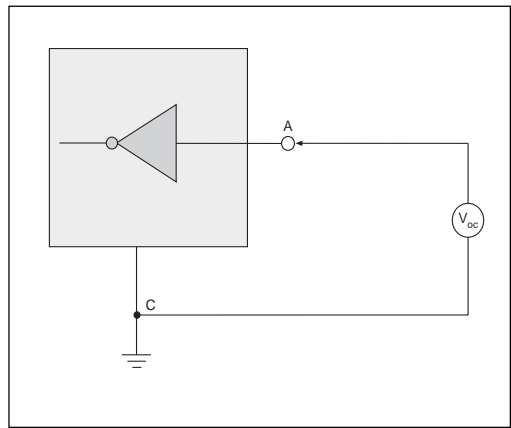

Figure 8. V.28 Receiver Input Open Circuit Bias

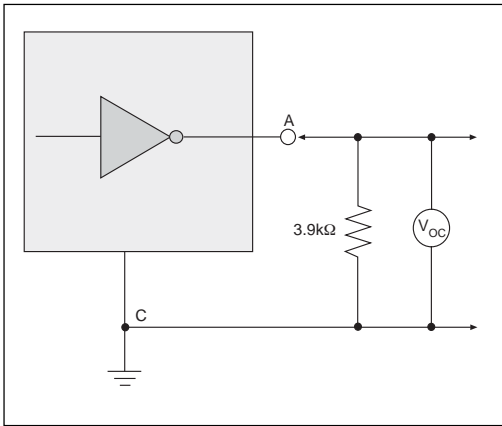

Figure 9. V.10 Driver Output Open-Circuit Voltage

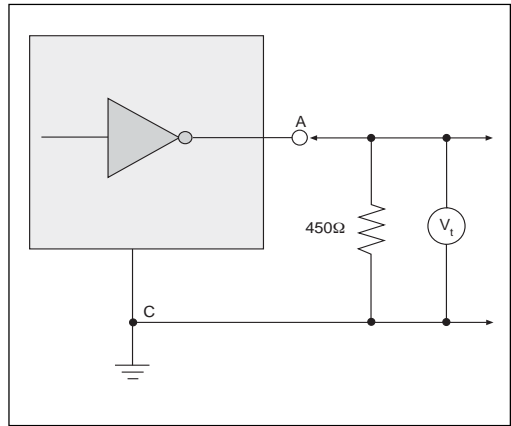

Figure 10. V.10 Driver Output Test Terminated Voltage

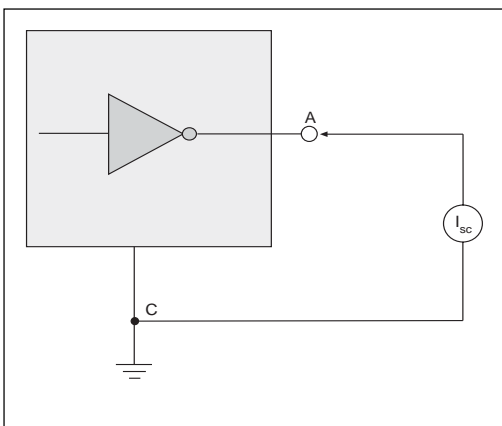

Figure 11. V.10 Driver Output Short-Circuit Current

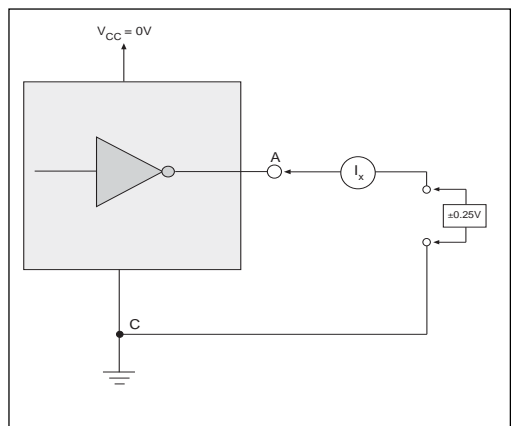

Figure 12. V.10 Driver Output Power-Off Current

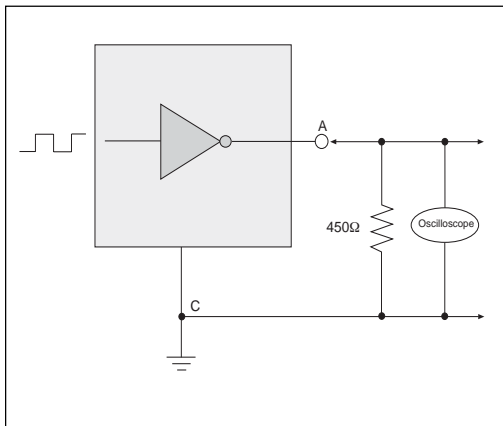

Figure 13. V.10 Driver Output Transition Time

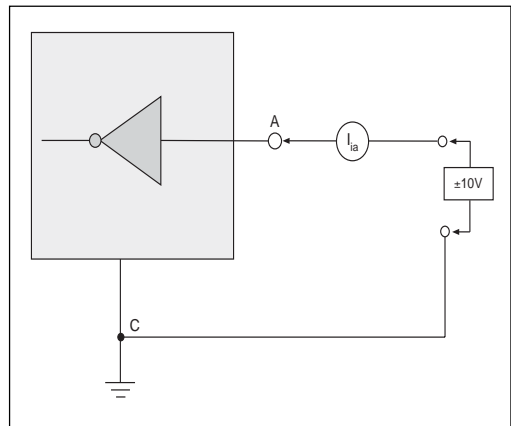

Figure 14. V.10 Receiver Input Current

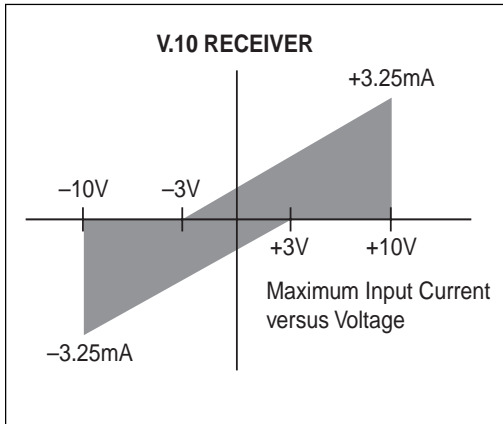

Figure 15. V.10 Receiver Input IV Graph

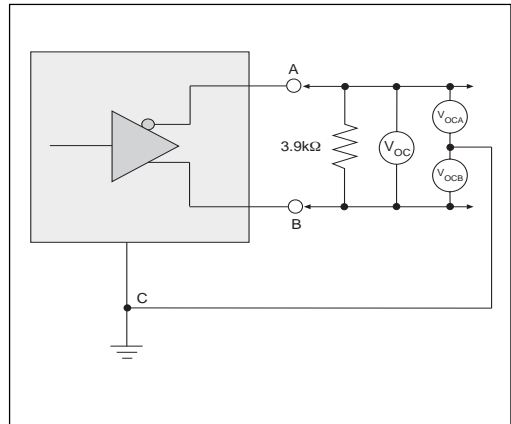

Figure 16. V.11 and V.35 Driver Output Open-Circuit Voltage

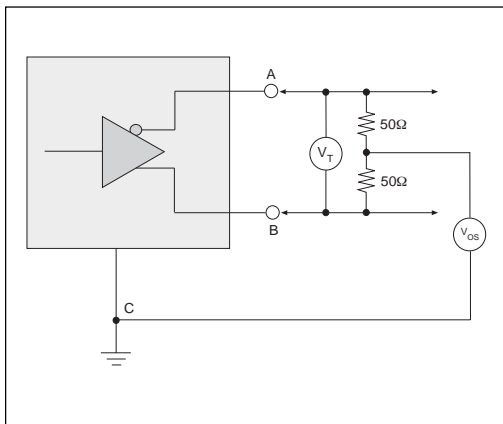

Figure 17. V.11 Driver Output Test Terminated Voltage

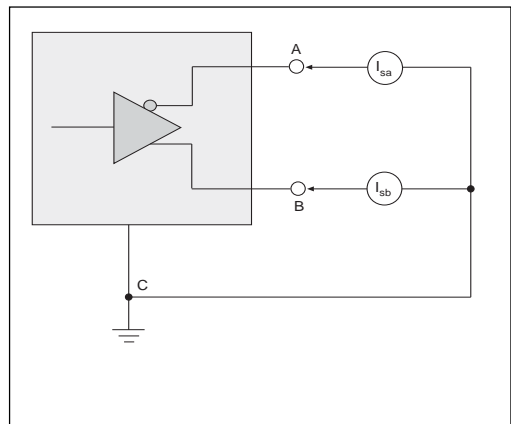

Figure 18. V.11 Driver Output Short-Circuit Current

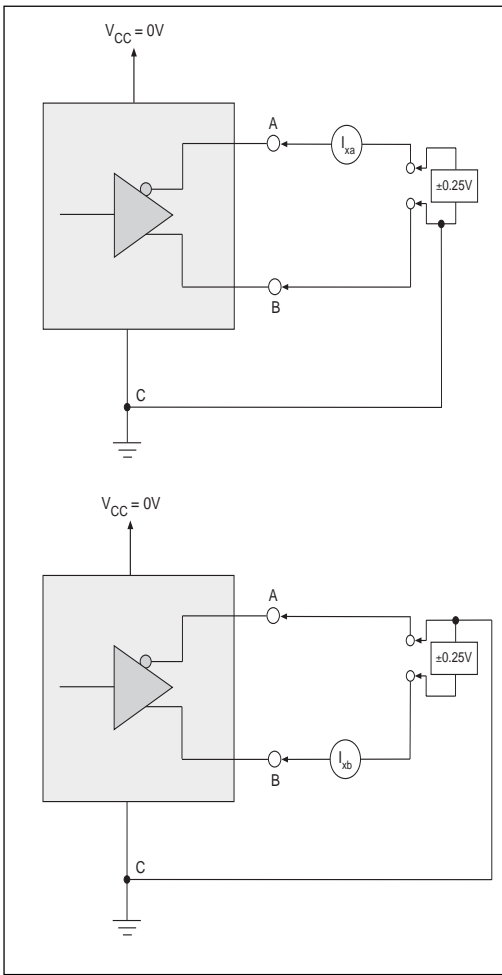

Figure 19. V.11 Driver Output Power-Off Current

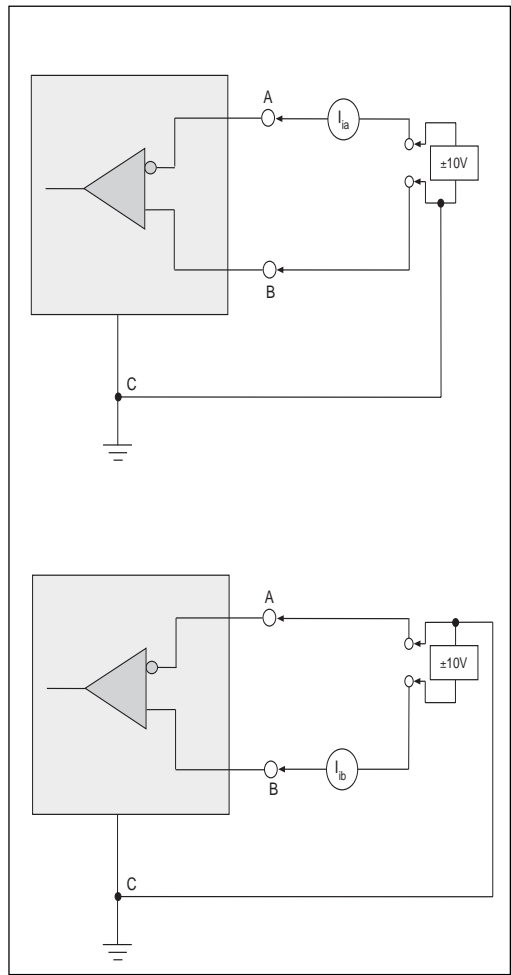

Figure 20. V.11 Receiver Input Current

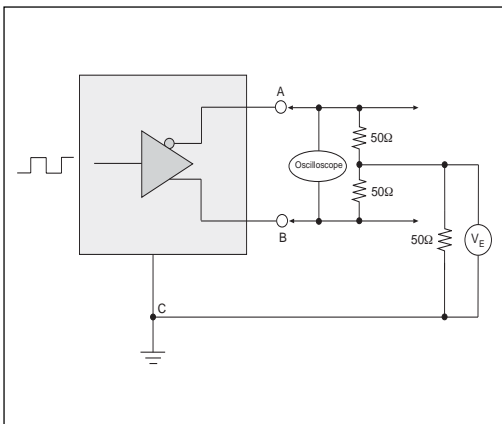

Figure 21. V.11 Driver Output Rise/Fall Time

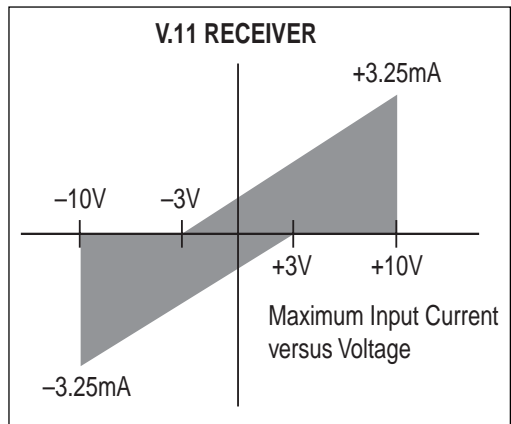

Figure 22. V.11 Receiver Input IV Graph

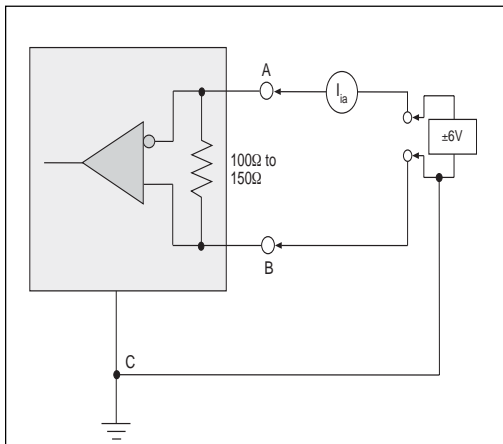

Figure 23. V.11 Receiver Input Current w/ Termination

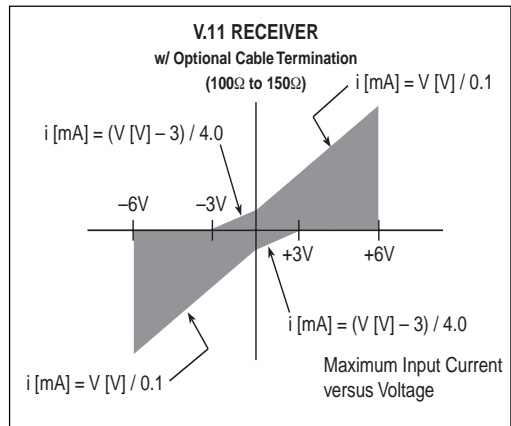

Figure 24. V.11 Receiver Input Graph w/ Termination

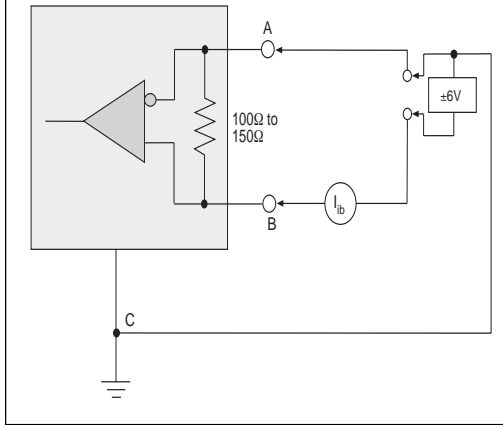

Figure 25. V.35 Driver Output Test Terminated Voltage

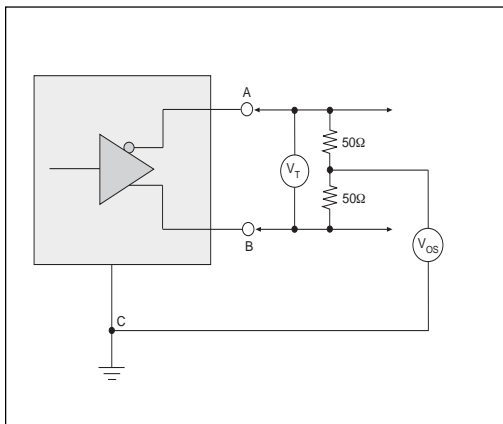

Figure 26. V.35 Driver Output Offset Voltage

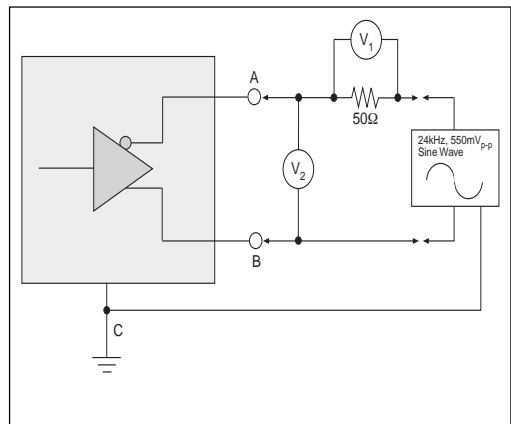

Figure 27. V.35 Driver Output Source Impedance

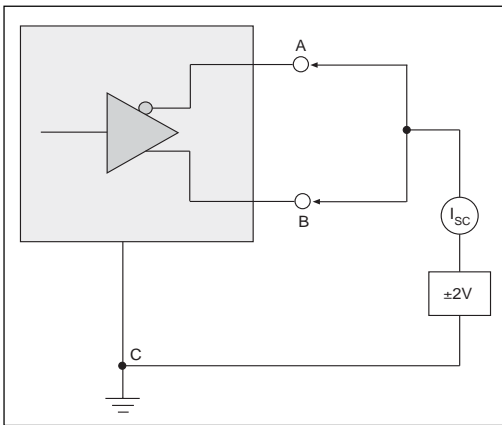

Figure 28. V.35 Driver Output Short-Circuit Impedance

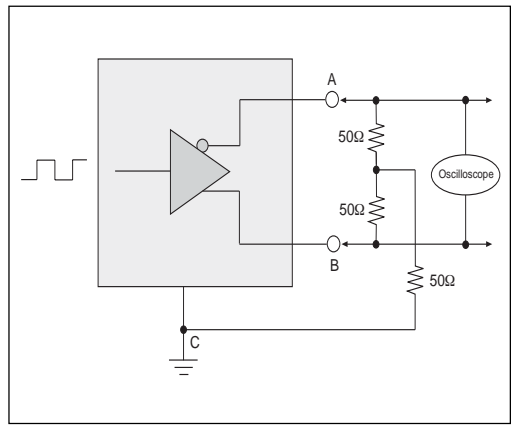

Figure 29. V.35 Driver Output Rise/Fall Time

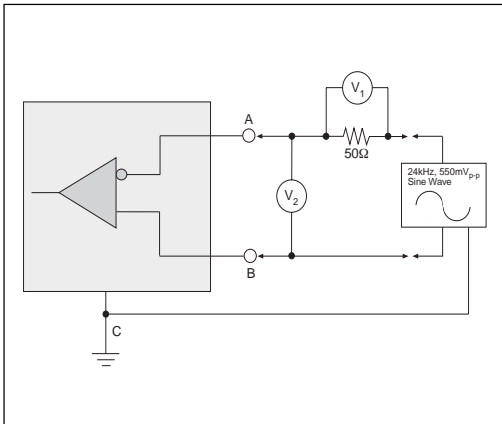

Figure 30. V.35 Receiver Input Source Impedance

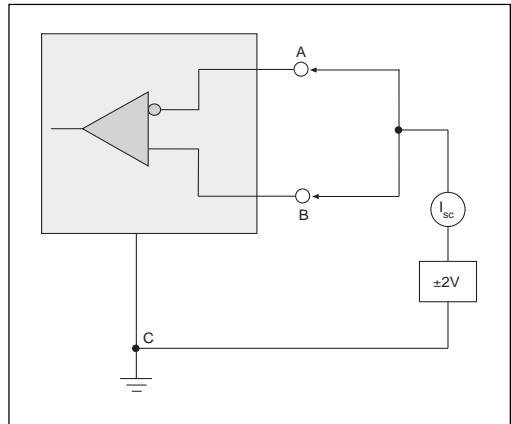

Figure 31. V.35 Receiver Input Short-Circuit Impedance

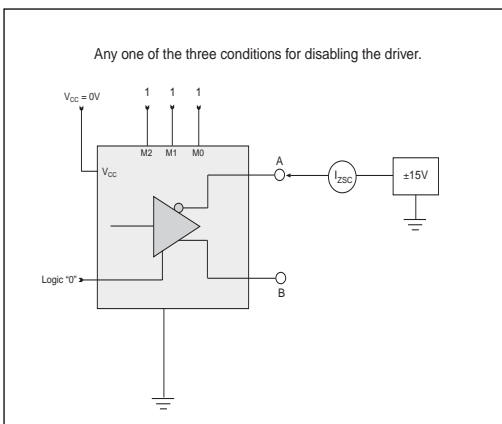

Figure 32. Driver Output Leakage Current Test

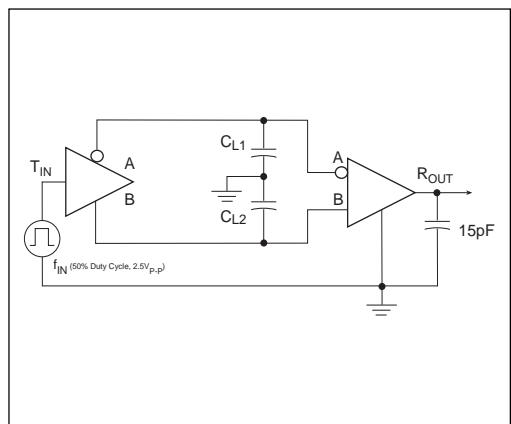

Figure 33. Driver/Receiver Timing Test Circuit

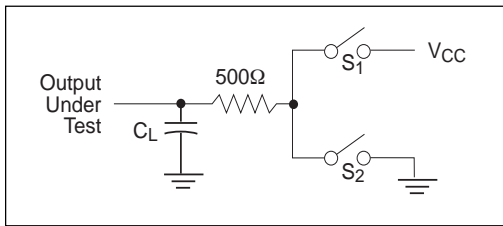

Figure 34. Driver Timing Test Load Circuit

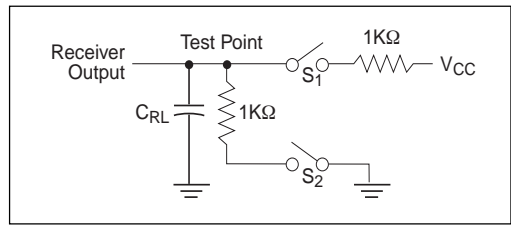

Figure 35. Receiver Timing Test Load Circuit

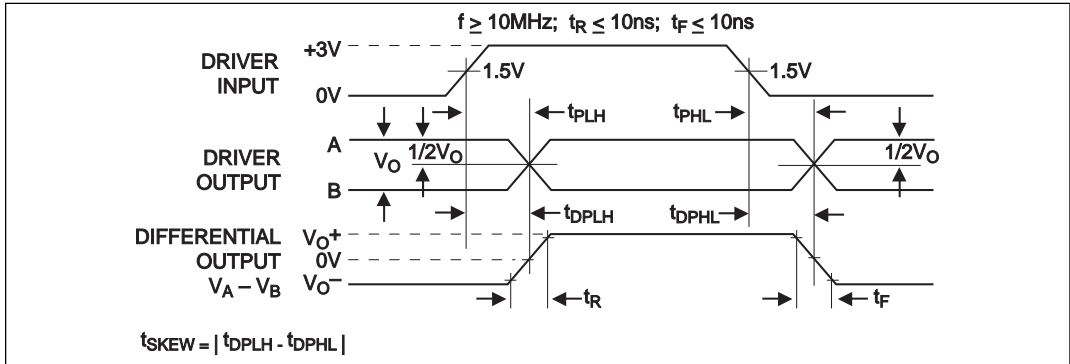

Figure 36. Driver Propagation Delays

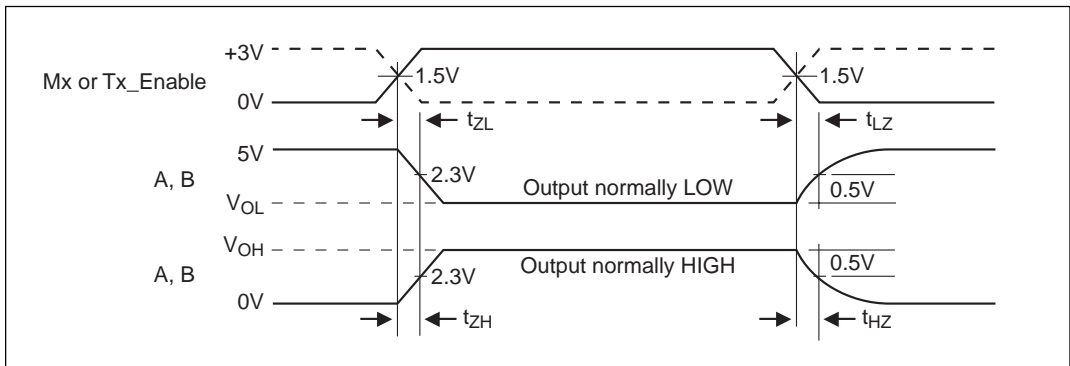

Figure 37. Driver Enable and Disable Times

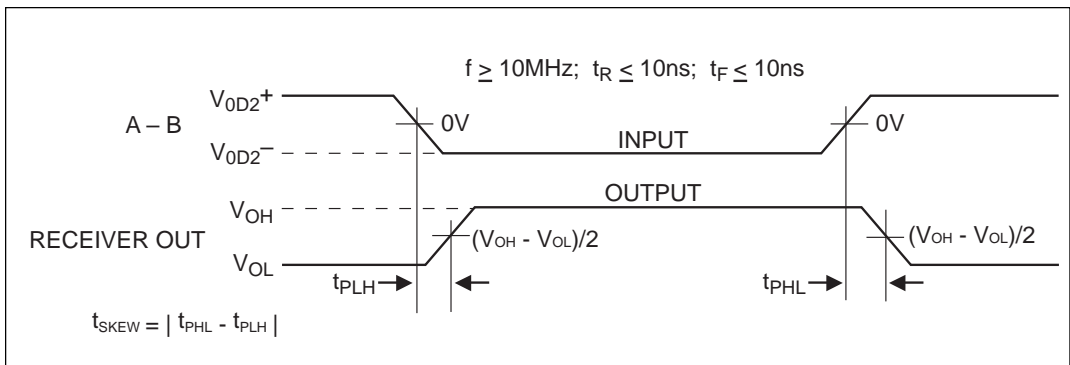

Figure 38. Receiver Propagation Delays

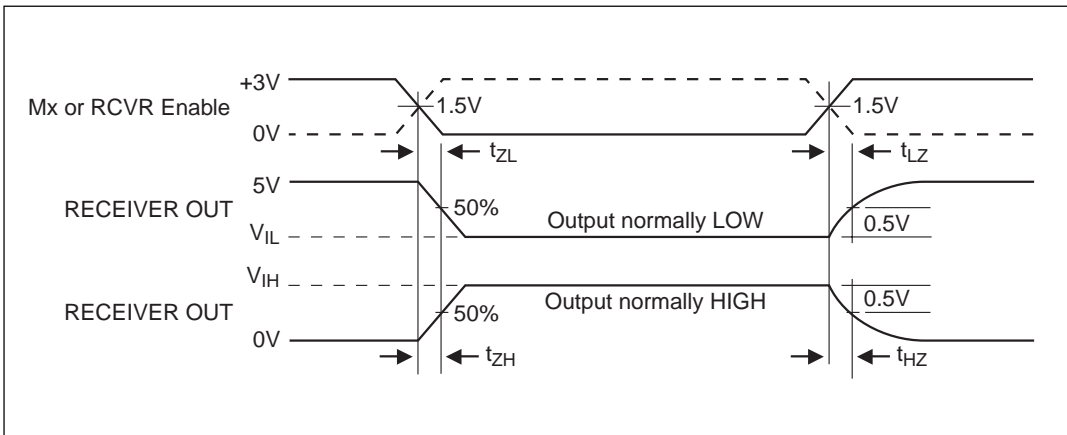

Figure 39. Receiver Enable and Disable Times

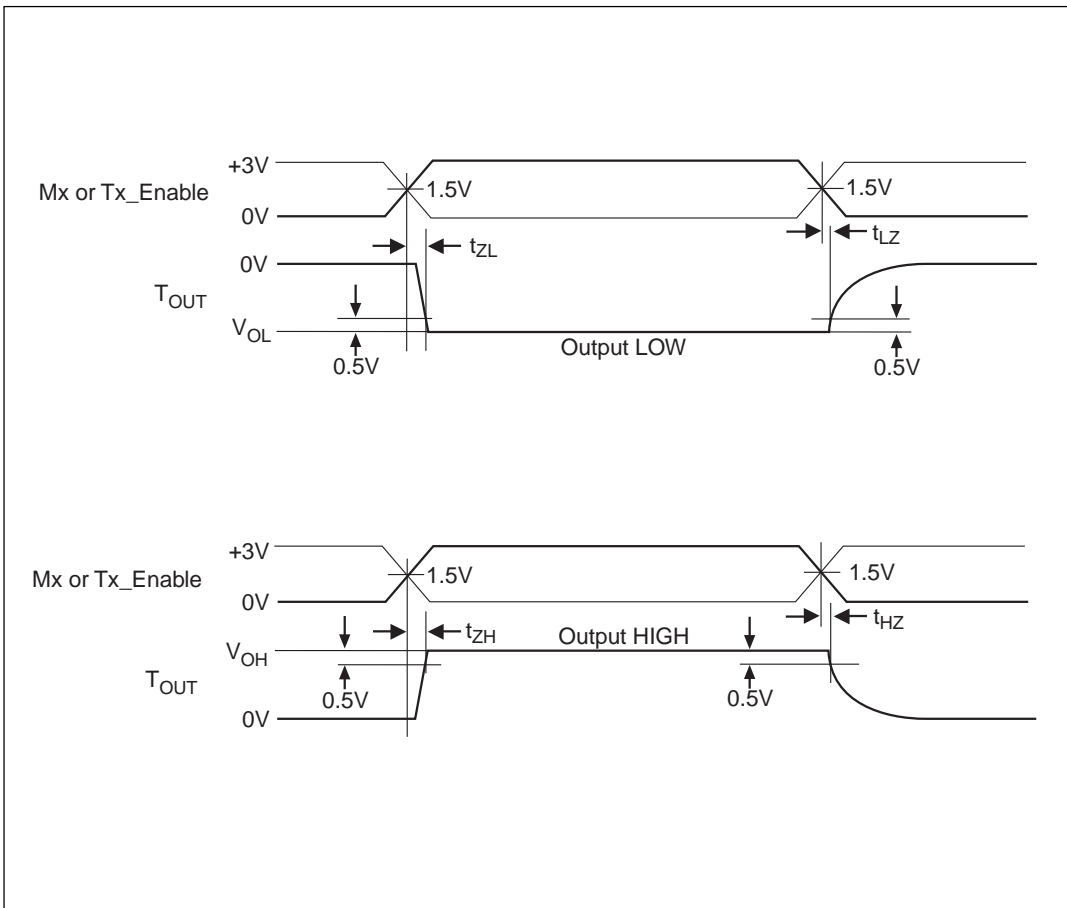

Figure 40. V.28 (RS-232) and V.10 (RS-423) Driver Enable and Disable Times

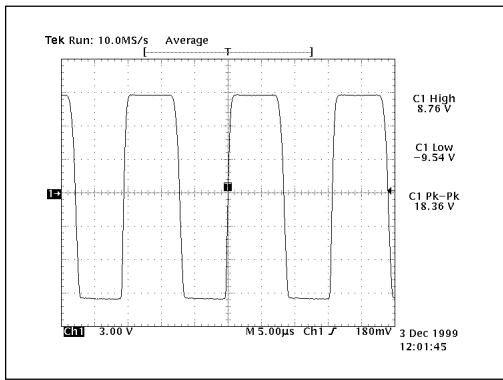

Figure 41. Typical V.28 Driver Output Waveform

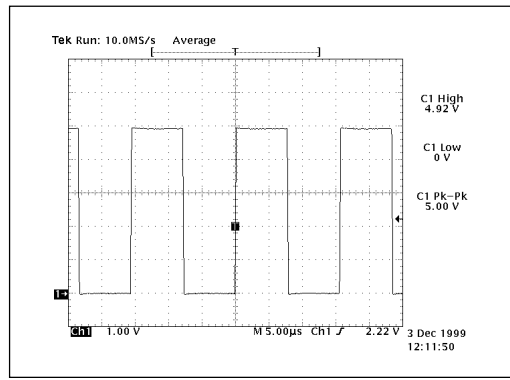

Figure 42. Typical V.10 Driver Output Waveform

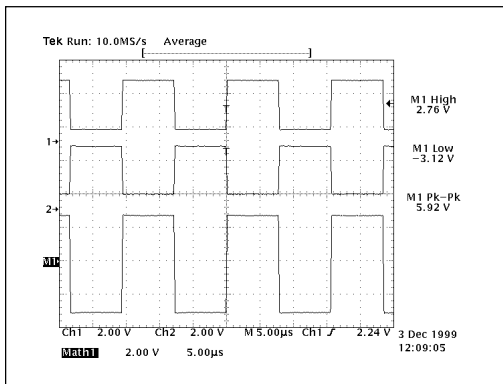

Figure 43. Typical V.11 Driver Output Waveforms

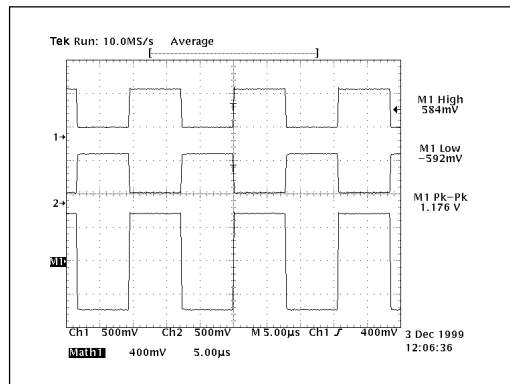
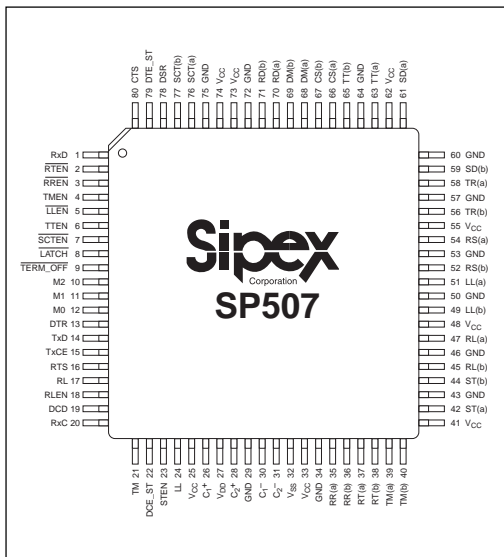

Figure 44. Typical V.35 Driver Output Waveforms

PINOUT (QFP)



PIN ASSIGNMENTS CLOCK AND DATA GROUP

Pin 1 — RxD — Receive Data; TTL output, sourced from RD(a) and RD(b) inputs.

Pin 14 — TxD — TTL input ; transmit data source for SD(a) and SD(b) outputs.

Pin 15 — TxCE — Transmit Clock; TTL input for TT driver outputs.

Pin 20 — RxC — Receive Clock; TTL output sourced from RT(a) and RT(b) inputs.

Pin 22 — DCE_ST — Send Timing; TTL input; source for ST(a) and ST(b) outputs.

Pin 37 — RT(a) — Receive Timing; analog input, inverted; source for RxC.

Pin 38 — RT(b) — Receive Timing; analog input, non-inverted; source for RxC.

Pin 42 — ST(a) — Send Timing; analog output, inverted; sourced from DCE_ST.

Pin 44 — ST(b) — Send Timing; analog output, non-inverted; sourced from DCE_ST.

Pin 59 — SD(b) — Analog Out — Send data, non-inverted; sourced from TxD.

Pin 61 — SD(a) — Analog Out — Send data, inverted; sourced from TxD.

Pin 63 — TT(a) — Analog Out — Terminal Timing, inverted; sourced from TxCE.

Pin 65 — TT(b) — Analog Out — Terminal Timing, non-inverted; sourced from TxCE.

Pin 70 — RD(a) — Receive Data, analog input; inverted; source for RxD.

Pin 71 — RD(b) — Receive Data; analog input; non-inverted; source for RxD.

Pin 76 — SCT(a) — Serial Clock Transmit; analog input, inverted; source for DCE_ST.

Pin 77 — SCT(b) — Serial Clock Transmit; analog input, non-inverted; source for DCE_ST.

Pin 79 — DTE_ST — Serial Clock Transmit; TTL output; sources from SCT(a) and SCT(b) inputs.

CONTROL LINE GROUP

Pin 13 — DTR — Data Terminal Ready; TTL input; source for TR(a) and TR(b) outputs.

Pin 16 — RTS — Ready To Send; TTL input; source for RS(a) and RS(b) outputs.

Pin 17 — RL — Remote Loopback; TTL input; source for RL(a) and RL(b) outputs.

Pin 19 — DCD — Data Carrier Detect; TTL output; sourced from RR(a) and RR(b) inputs.

Pin 21 — TM — Ring In; TTL output; sourced from TM(a) and TM(b) inputs.

Pin 24 — LL — Local Loopback; TTL input; source for LL(a) and LL(b) outputs.

Pin 35 — RR(a) — Receiver Ready; analog input, inverted; source for DCD.

Pin 36 — RR(b) — Receiver Ready; analog input, non-inverted; source for DCD.

Pin 39 — TM(a) — Incoming Call; analog input, inverted; source for TM.

Pin 40 — TM(b) — Incoming Call; analog input, non-inverted; source for TM.

Pin 45 — RL(b) — Remote Loopback; analog output, non-inverted; sourced from RL.

Pin 47 — RL(a) — Remote Loopback; analog output inverted; sourced from RL.

Pin 49 — LL(b) — Local Loopback; analog output, non-inverted; sourced from LL.

Pin 51 — LL(a) — Local Loopback; analog output, inverted; sourced from LL.

Pin 52 — RS(b) — Ready To Send; analog output, non-inverted; sourced from RTS.

Pin 54 — RS(a) — Ready To Send; analog output, inverted; sourced from RTS.

Pin 56 — TR(b) — Terminal Ready; analog output, non-inverted; sourced from DTR.

Pin 58 — TR(a) — Terminal Ready; analog output, inverted; sourced from DTR.

Pin 66 — CS(a) — Clear To Send; analog input, inverted; source for CTS.

Pin 67 — CS(b) — Clear To Send; analog input, non-inverted; source for CTS.

Pin 68 — DM(a) — Data Mode; analog input, inverted; source for DSR.

Pin 69 — DM(b) — Data Mode; analog input, non-inverted; source for DSR

Pin 78 — DSR — Data Set Ready; TTL output; sourced from DM(a) and DM(b) inputs.

Pin 80 — CTS — Clear To Send; TTL output; sourced from CS(a) and CS(b) inputs.

CONTROL REGISTERS

Pin 2 — $\overline{\text{RTEN}}$ — Enables RxC receiver, active low; TTL input.

Pin 3 — $\overline{\text{RREN}}$ — Enables DCD receiver, active low; TTL input.

Pin 4 — TMEN — Enables TM receiver, active high; TTL input.

Pin 5 — $\overline{\text{LLEN}}$ — Enables LL driver, active low; TTL input.

Pin 6 — TTEN — Enables TxCE driver, active high; TTL input.

Pin 7 — $\overline{\text{SCTEN}}$ — Enables DTE_ST receiver; active low; TTL input.

Pin 8 — $\overline{\text{LATCH}}$ — Latch control for decoder bits (pins 10-12), active low. Logic high input will make decoder transparent.

Pin 9 — $\overline{\text{TERM_OFF}}$ — Disables receiver termination networks for RxD, RxC, and DTE_ST; TTL input.

Pins 10,11, 12 — M2, M1, M0 — Transmitter and receiver decode register; configures transmitter and receiver modes; TTL inputs.

Pin 18 — RLEN — Enables RL driver; active high; TTL input.

Pin 23 — STEN — Enables DTE_ST driver; active high; TTL input.

POWER SUPPLIES

Pins 25, 33, 41, 48, 55, 62, 73, 74 — V_{CC} — +5V input.

Pins 29, 34, 43, 46, 50, 53, 57, 60, 64, 72, 75 — GND — Ground.

Pin 27 — $V_{DD} + 10V$ Charge Pump Capacitor — Connects from V_{DD} to V_{CC} . Suggested capacitor size is 22 μ F, 16V.

Pin 32 — $V_{SS} - 10V$ Charge Pump Capacitor — Connects from ground to V_{SS} . Suggested capacitor size is 22 μ F, 16V.

Pins 26 and 30 — C_1^+ and C_1^- — Charge Pump Capacitor — Connects from C_1^+ to C_1^- . Suggested capacitor size is 22 μ F, 16V.

Pins 28 and 31 — C_2^+ and C_2^- — Charge Pump Capacitor — Connects from C_2^+ to C_2^- . Suggested capacitor size is 22 μ F, 16V.

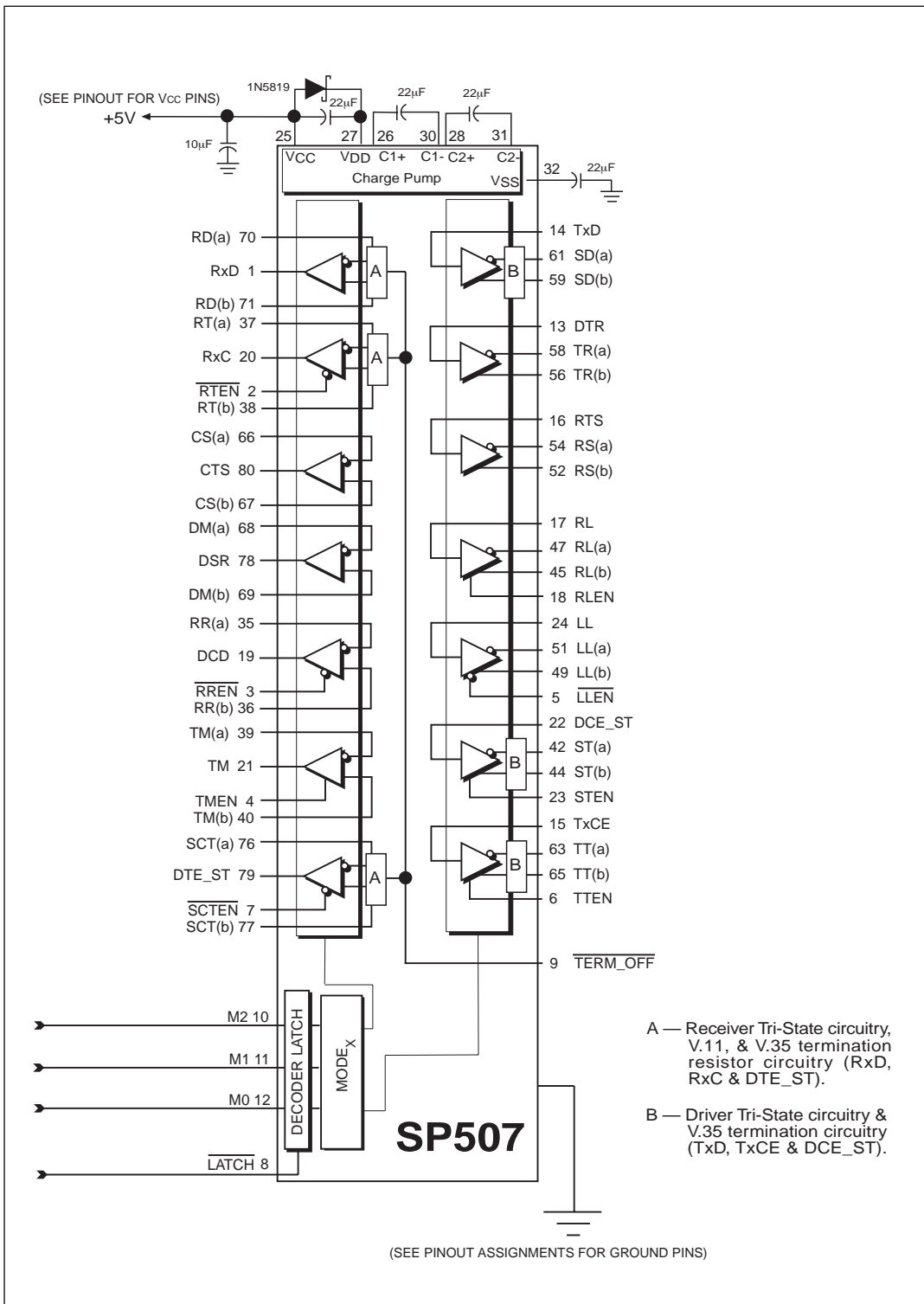

Figure 45. Typical Operating Circuit

SP507 Driver Mode Selection

| Pin Label | Mode | V.11 | EIA-530A | EIA-530 | X.21 | V.35 | RS-449 | RS-232 |
|----------------|------------|------------|------------|------------|------------|-----------------------------------------------------------------------------------------|------------|------------|
| M2 - M0 | 111 | 000 | 001 | 010 | 011 | 100 | 101 | 110 |
| SD(a) | 3-state | V.11- | V.11- | V.11- | V.11- | V.35-  | V.11- | V.28 |
| SD(b) | 3-state | V.11+ | V.11+ | V.11+ | V.11+ | V.35+  | V.11+ | 3-state |
| TR(a) | 3-state | V.11- | V.10 | V.11- | V.11- | V.28 | V.11- | V.28 |
| TR(b) | 3-state | V.11+ | 3-state | V.11+ | V.11+ | 3-state | V.11+ | 3-state |
| RS(a) | 3-state | V.11- | V.11- | V.11- | V.11- | V.28 | V.11- | V.28 |
| RS(b) | 3-state | V.11+ | V.11+ | V.11+ | V.11+ | 3-state | V.11+ | 3-state |
| RL(a) | 3-state | V.11- | V.11- | V.11- | V.11- | V.28 | V.11- | V.28 |
| RL(b) | 3-state | V.11+ | V.11+ | V.11+ | V.11+ | 3-state | V.11+ | 3-state |
| LL(a) | 3-state | V.10 | V.10 | V.10 | V.10 | V.28 | V.10 | V.28 |
| LL(b) | 3-state | 3-state | 3-state | 3-state | 3-state | 3-state | 3-state | 3-state |
| ST(a) | 3-state | V.11- | V.11- | V.11- | V.11- | V.35-  | V.11- | V.28 |
| ST(b) | 3-state | V.11+ | V.11+ | V.11+ | V.11+ | V.35+  | V.11+ | 3-state |
| TT(a) | 3-state | V.11- | V.11- | V.11- | V.11- | V.35-  | V.11- | V.28 |
| TT(b) | 3-state | V.11+ | V.11+ | V.11+ | V.11+ | V.35+  | V.11+ | 3-state |

Table 1. SP507 Driver Decoder Table

SP507 Receiver Mode Selection





































| Pin Label | Mode | V.11 | EIA-530A | EIA-530 | X.21 | V.35 | RS-449 | RS-232 |
|----------------|--------------|-------------------------------------------------------------------------------------------|-------------------------------------------------------------------------------------------|-------------------------------------------------------------------------------------------|-------------------------------------------------------------------------------------------|--------------------------------------------------------------------------------------------|---------------------------------------------------------------------------------------------|--------------|
| M2 - M0 | 111 | 000 | 001 | 010 | 011 | 100 | 101 | 110 |
| RD(a) | >10kΩ to GND | V.11-  | V.11-  | V.11-  | V.11-  | V.35-  | V.11-  | V.28 |
| RD(b) | >10kΩ to GND | V.11+  | V.11+  | V.11+  | V.11+  | V.35+  | V.11+  | >10kΩ to GND |
| RT(a) | >10kΩ to GND | V.11-  | V.11-  | V.11-  | V.11-  | V.35-  | V.11-  | V.28 |
| RT(b) | >10kΩ to GND | V.11+  | V.11+  | V.11+  | V.11+  | V.35+  | V.11+  | >10kΩ to GND |
| CS(a) | >10kΩ to GND | V.11- | V.11- | V.11- | V.11- | V.28 | V.11- | V.28 |
| CS(b) | >10kΩ to GND | V.11+ | V.11+ | V.11+ | V.11+ | >10kΩ to GND | V.11+ | >10kΩ to GND |
| DM(a) | >10kΩ to GND | V.11- | V.10 | V.11- | V.11- | V.28 | V.11- | V.28 |
| DM(b) | >10kΩ to GND | V.11+ | >10kΩ to GND | V.11+ | V.11+ | >10kΩ to GND | V.11+ | >10kΩ to GND |
| RR(a) | >10kΩ to GND | V.11- | V.11- | V.11- | V.11- | V.28 | V.11- | V.28 |
| RR(b) | >10kΩ to GND | V.11+ | V.11+ | V.11+ | V.11+ | >10kΩ to GND | V.11+ | >10kΩ to GND |
| TM(a) | >10kΩ to GND | V.10 | V.10 | V.10 | V.10 | V.28 | V.10 | V.28 |
| TM(b) | >10kΩ to GND | >10kΩ to GND | >10kΩ to GND | >10kΩ to GND | >10kΩ to GND | >10kΩ to GND | >10kΩ to GND | >10kΩ to GND |
| SCT(a) | >10kΩ to GND | V.11-  | V.11-  | V.11-  | V.11-  | V.35-  | V.11-  | V.28 |
| SCT(b) | >10kΩ to GND | V.11+  | V.11+  | V.11+  | V.11+  | V.35+  | V.11+  | >10kΩ to GND |

Table 2. SP507 Receiver Decoder Table

| MODE: V.11 | | |
|-----------------|----|----|
| DRIVER/RECEIVER | | |
| M2 | M1 | M0 |
| 0 | 0 | 0 |

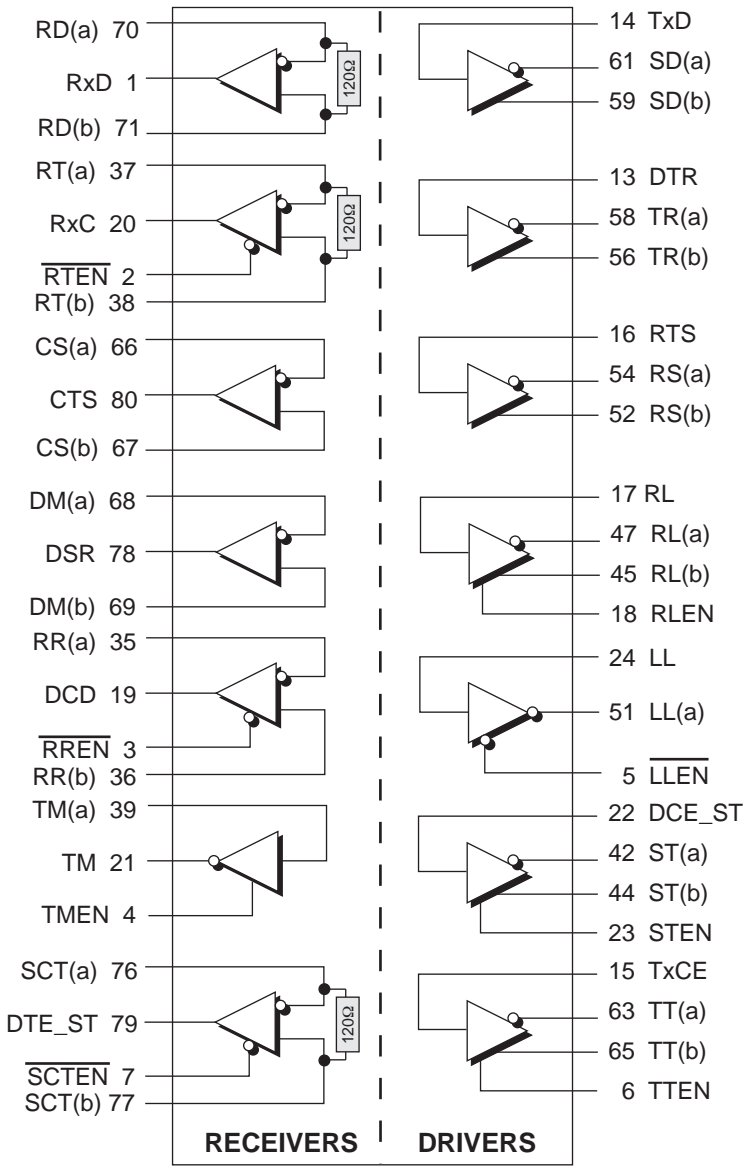

Figure 46. Mode Diagram - V.11

| MODE: EIA-530A | | |
|-----------------|----|----|
| DRIVER/RECEIVER | | |
| M2 | M1 | M0 |
| 0 | 0 | 1 |

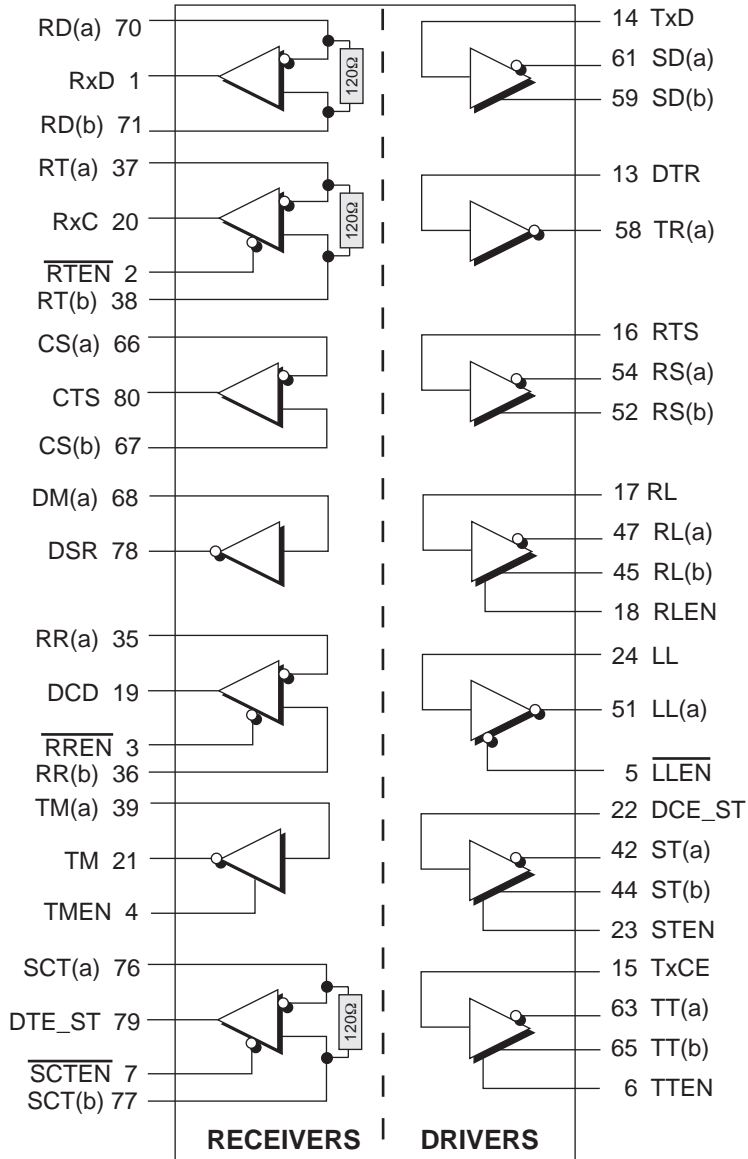

Figure 47. Mode Diagram – EIA-530A

| MODE: EIA-530 | | |
|-----------------|----|----|
| DRIVER/RECEIVER | | |
| M2 | M1 | M0 |
| 0 | 1 | 0 |

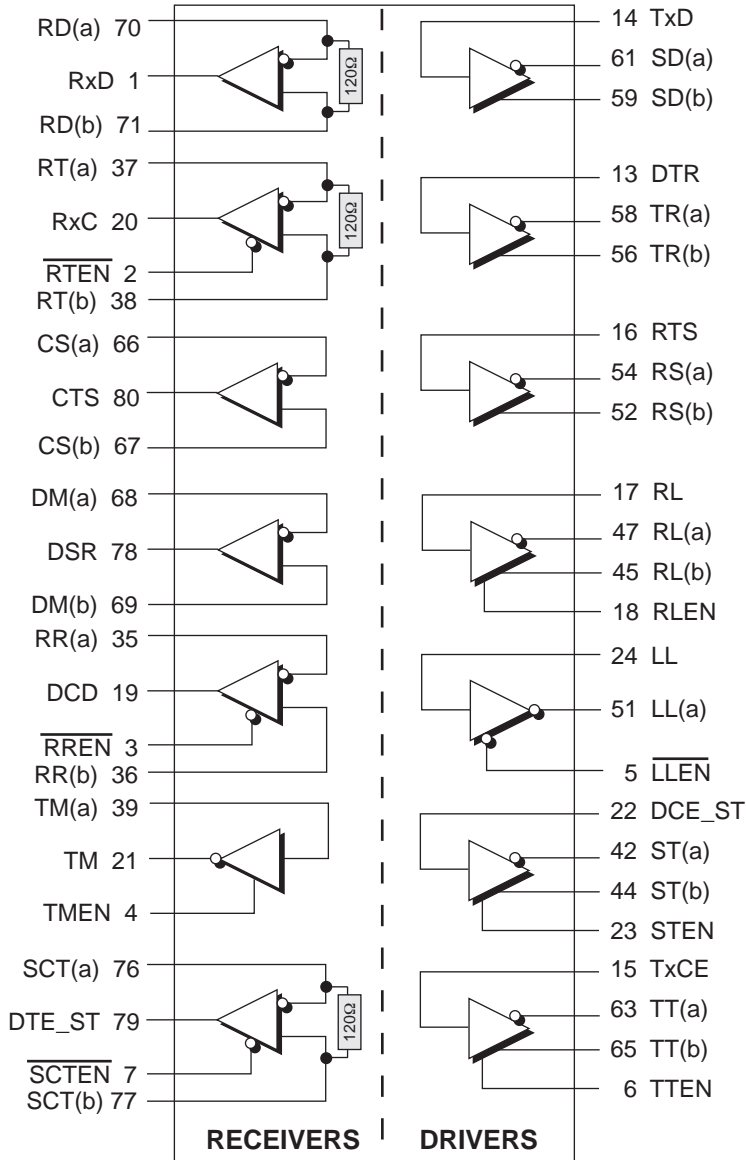

Figure 48. Mode Diagram – EIA-530

| MODE: X.21 | | |
|-----------------|----|----|
| DRIVER/RECEIVER | | |
| M2 | M1 | M0 |
| 0 | 1 | 1 |

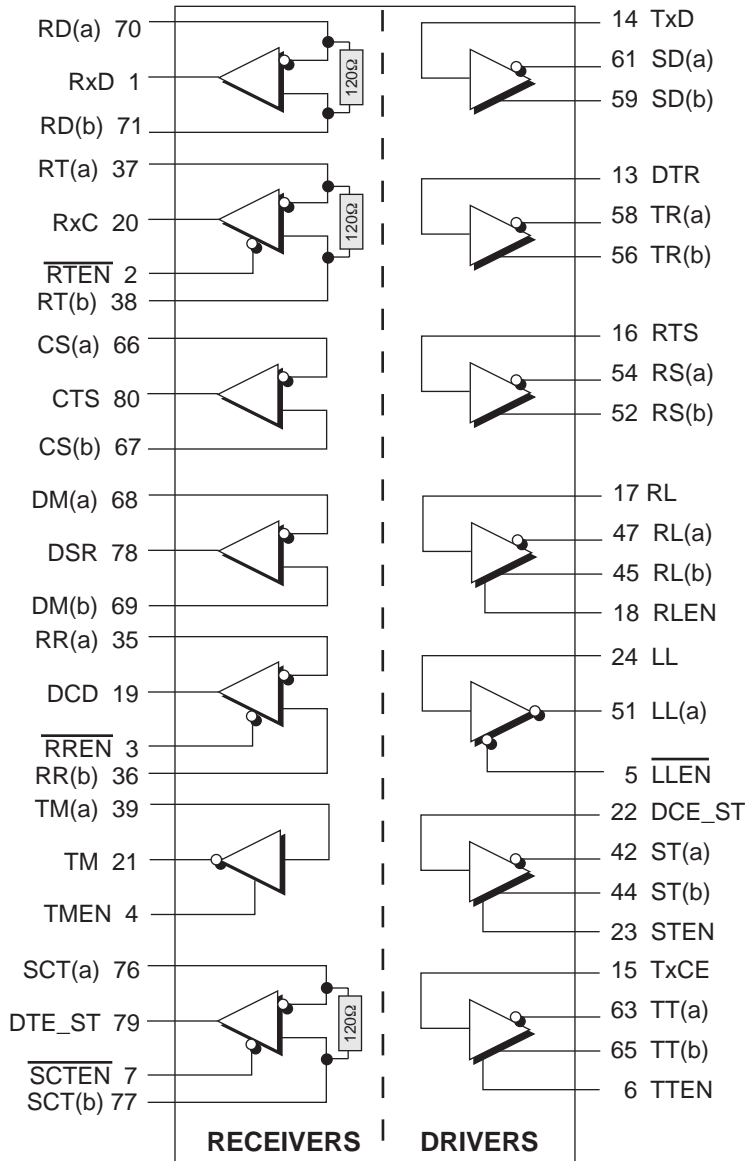

Figure 49. Mode Diagram - X.21

| MODE: V.35 | | |
|-----------------|----|----|
| DRIVER/RECEIVER | | |
| M2 | M1 | M0 |
| 1 | 0 | 0 |

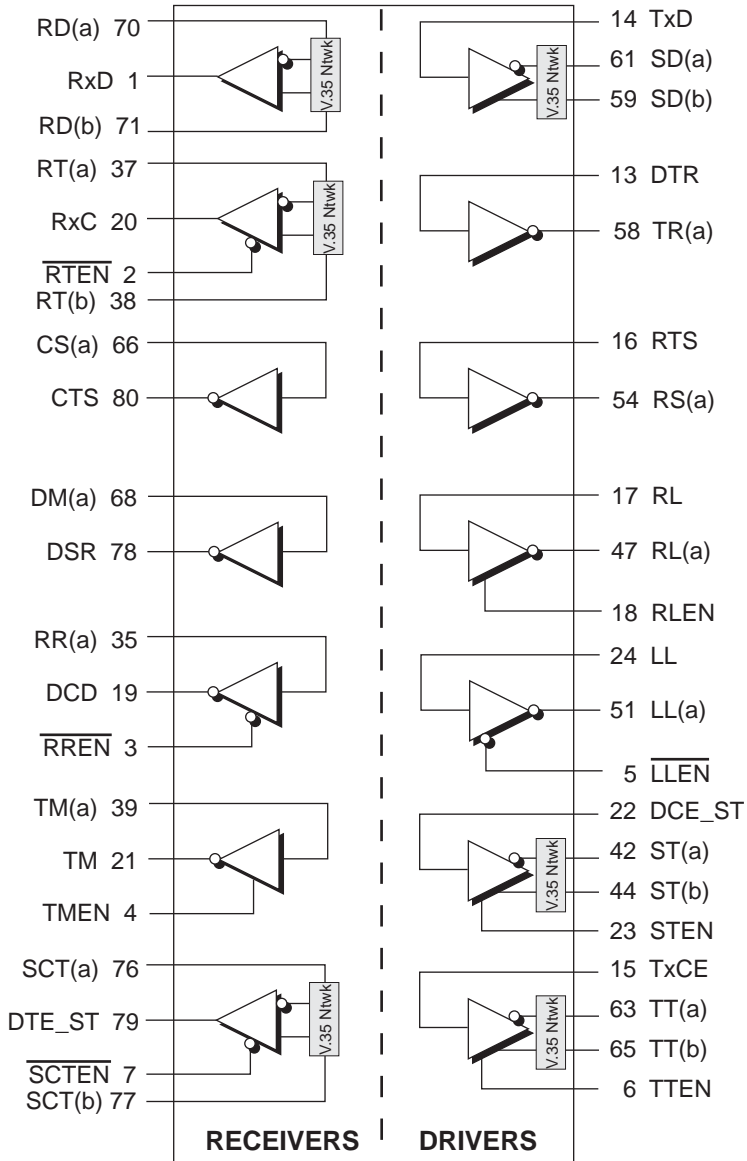

Figure 50. Mode Diagram – V.35

| MODE: RS-449 | | |
|-----------------|----|----|
| DRIVER/RECEIVER | | |
| M2 | M1 | M0 |
| 1 | 0 | 1 |

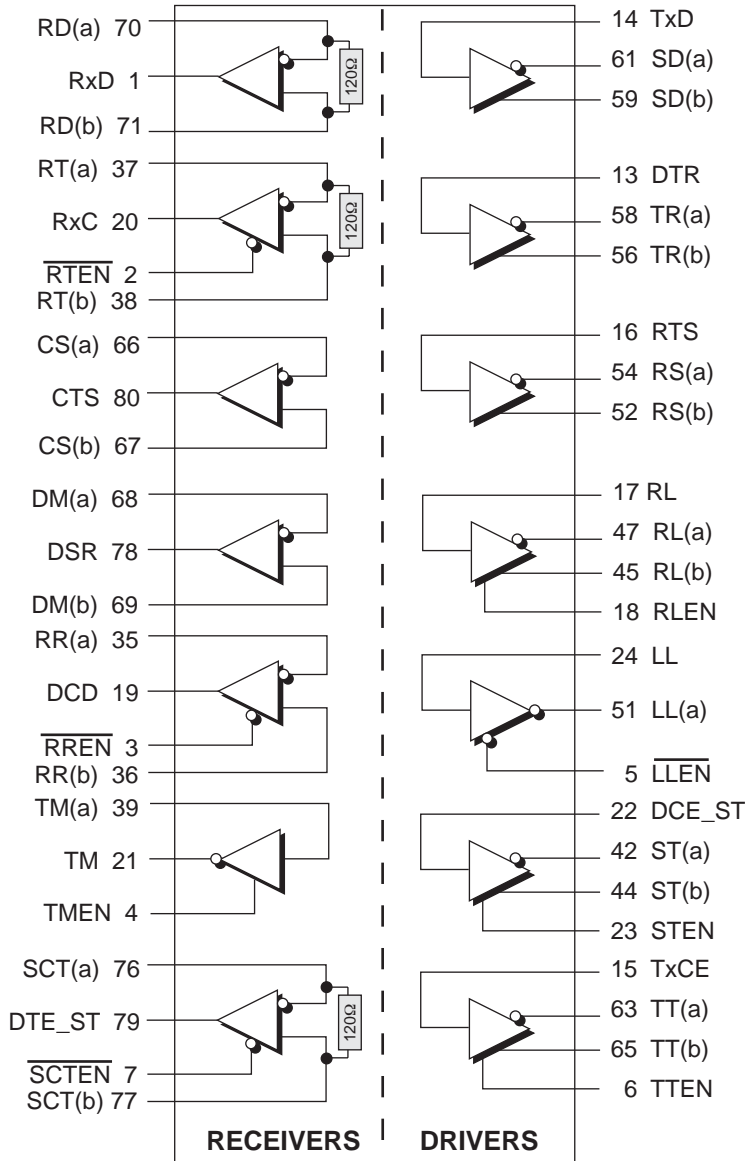

Figure 51. Mode Diagram – RS-449

| MODE: RS-232 (V.28) | | |
|---------------------|----|----|
| DRIVER/RECEIVER | | |
| M2 | M1 | M0 |
| 1 | 1 | 0 |

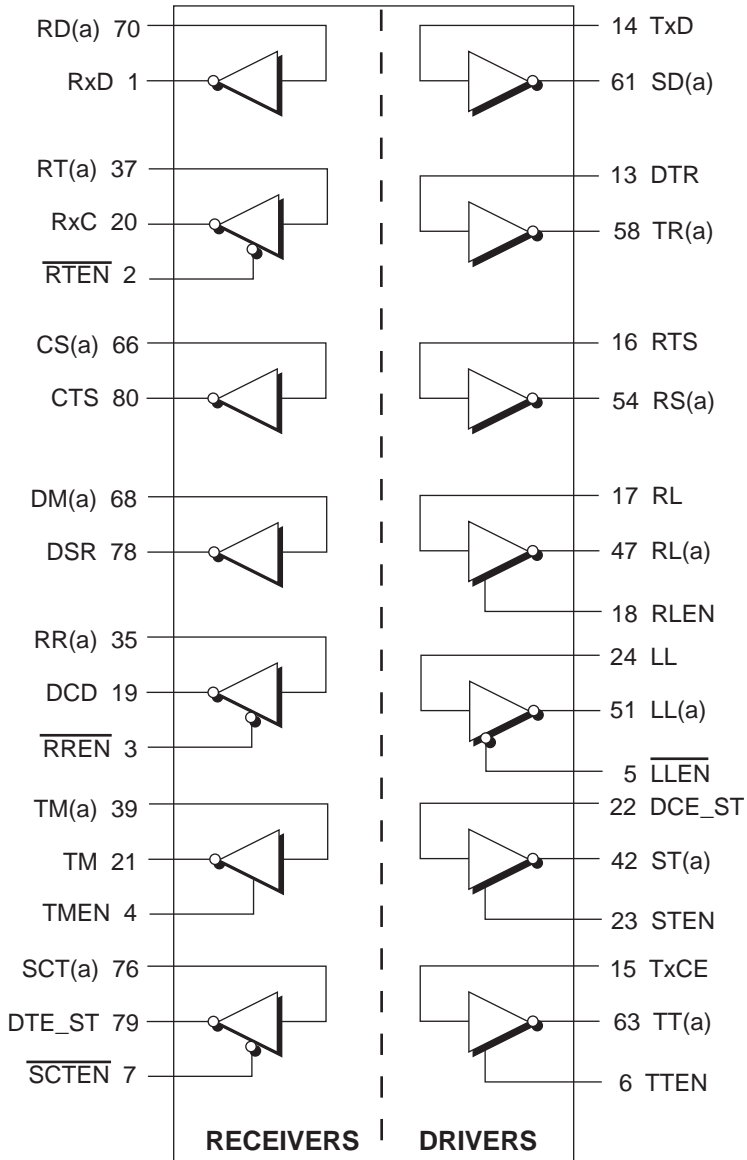
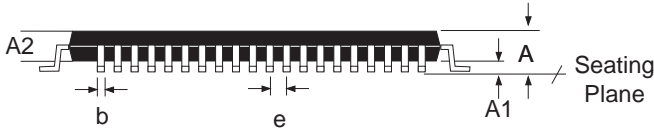
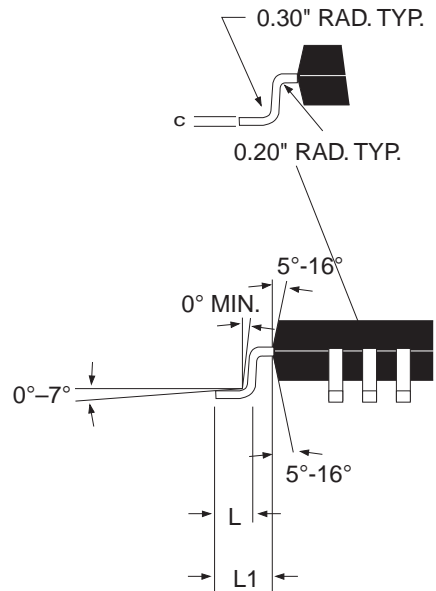
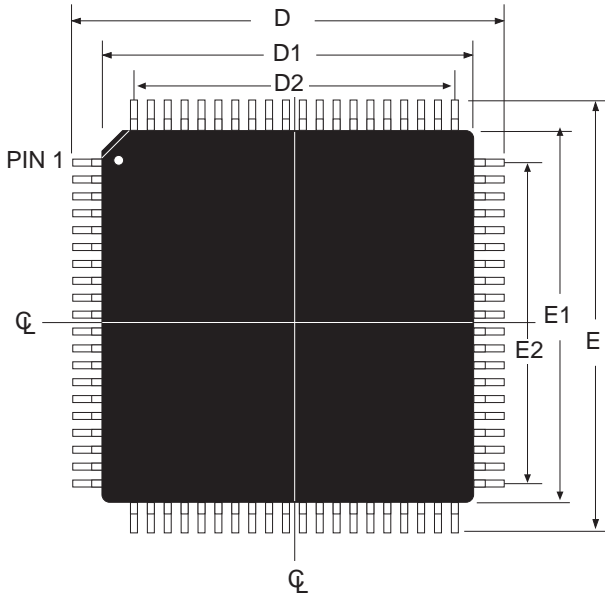

Figure 52. Mode Diagram – RS-232

PACKAGE: 80 PIN MQFP



| DIMENSIONS Minimum/Maximum (mm) | 80-PIN MQFP JEDEC MS-22 (BEC) Variation | | |
|---------------------------------------|-----------------------------------------------|------|------|
| | MIN | NOM | MAX |
| A | | | 2.45 |
| A1 | 0.00 | | 0.25 |
| A2 | 1.80 | 2.00 | 2.20 |
| b | 0.22 | | 0.40 |
| D | 17.20 BSC | | |
| D1 | 14.00 BSC | | |
| D2 | 12.35 REF | | |
| E | 17.20 BSC | | |
| E1 | 14.00 BSC | | |
| E2 | 12.35 REF | | |
| e | 0.65 BSC | | |
| N | 80 | | |

| COMMON DIMENSIONS | | | |
|-------------------|------------|------|-------|
| SYMBL | MIN | NOM | MAX |
| c | 0.11 | | 23.00 |
| L | 0.73 | 0.88 | 1.03 |
| L1 | 1.60 BASIC | | |

80 PIN MQFP (MS-022 BC)

ORDERING INFORMATION

| Model | Temperature Range | Package Types |
|---------------|--------------------|----------------------------------|
| SP507CF | 0°C to +70°C | 80-pin JEDEC (BE-2 Outline) MQFP |

Please consult the factory for pricing and availability on a Tape-On-Reel option.

REVISION HISTORY

| DATE | REVISION | DESCRIPTION |
|---------|----------|--------------------------------|
| 1/27/04 | A | Implemented tracking revision. |
| | | |
| | | |



ANALOG EXCELLENCE

Sipex Corporation

Headquarters and Sales Office

233 South Hillview Drive
Milpitas, CA 95035
TEL: (408) 934-7500
FAX: (408) 935-7600

Sales Office

22 Linnell Circle
Billerica, MA 01821
TEL: (978) 667-8700
FAX: (978) 670-9001
e-mail: sales@sipex.com

Sipex Corporation reserves the right to make changes to any products described herein. Sipex does not assume any liability arising out of the application or use of any product or circuit described herein; neither does it convey any license under its patent rights nor the rights of others.