

## WAN Multi-Mode Serial Transceiver

- Low-Cost Programmable Serial Transceiver
- Four (4) Drivers and Four (4) Receivers
- Driver and Receiver Tri-state Control
- Software Selectable Protocol Selection
- Interface Modes:
  - ✓ RS-232 (V.28)
  - ✓ RS-422 (V.11, X.21)
  - ✓ EIA-530 or RS-449 (V.10, V.11)
- Designed to Meet All NET1/2 Compliancy Requirements
- High ESD Tolerance
  - ✓ ±15kV per Human Body Model
  - ✓ ±15kV per IEC1000-4-2 Air Discharge
  - ✓ ±8kV per IEC1000-4-2 Contact Discharge

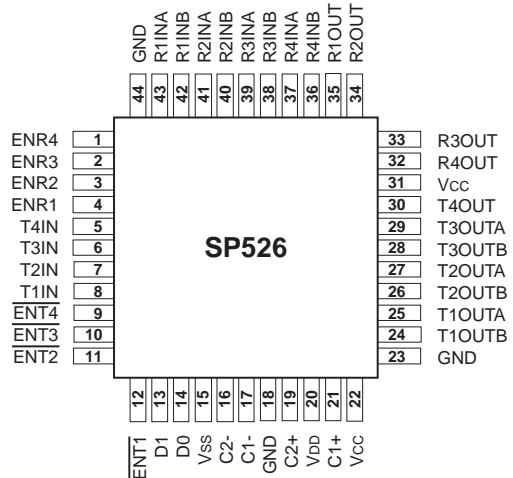

*Now Available in Lead Free Packaging*

### DESCRIPTION

The **SP526** is a monolithic device that supports three (3) physical layer serial interface standards. The **SP526** is fabricated using a low power BiCMOS process technology, and incorporates four (4) drivers and four (4) receivers can be configured via software for the selected interface modes at any time. The **SP526** includes tri-state ability for the driver and receiver outputs through separate enable lines. A shutdown mode is also included through the mode select pins for power savings. When mated with the **SP322** V.11/V.35 Programmable Transceiver, the **SP526** provides the four (4) channels needed for handshaking/control lines such as CTS, RTS, etc. The two transceiver ICs are an ideal solution for WAN serial ports in networking equipment such as routers, DSU/CSU's, and other access devices.

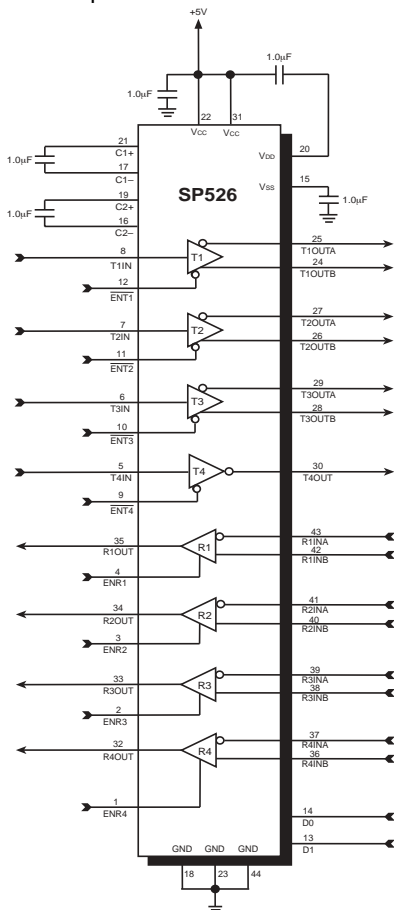

## ABSOLUTE MAXIMUM RATINGS

These are stress ratings only and functional operation of the device at these ratings or any other above those indicated in the operation sections of the specifications below is not implied. Exposure to absolute maximum rating conditions for extended periods of time may affect reliability.

$V_{CC}$ .....+7V

Input Voltages:

Logic.....-0.3V to ( $V_{CC}+0.5V$ )

Drivers.....-0.3V to ( $V_{CC}+0.5V$ )

Receivers..... $\pm 15.5V$

Output Voltages:

Logic.....-0.3V to ( $V_{CC}+0.5V$ )

Drivers..... $\pm 15V$

Receivers.....-0.3V to ( $V_{CC}+0.5V$ )

Storage Temperature.....-65°C to +150°C

Power Dissipation

(derate 14.3mW/°C above 70°C).....1144mW

## STORAGE CONSIDERATIONS

Due to the relatively large package size of the 44-pin quad flat-pack, storage in a low humidity environment is preferred. Large high density plastic packages are moisture sensitive and should be stored in Dry Vapor Barrier Bags. Prior to usage, the parts should remain bagged and stored below 40°C and 60%RH. If the parts are removed from the bag, they should be used within 48 hours or stored in an environment at or below 20%RH. If the above conditions cannot be followed, the parts should be baked for four hours at 125°C in order to remove moisture prior to soldering. Sipex ships the 44-pin QFP in Dry Vapor Barrier Bags with a humidity indicator card and desiccant pack. The humidity indicator should be below 30%RH.

## ELECTRICAL CHARACTERISTICS

$T_A = +25^\circ\text{C}$  and  $V_{CC} = +4.75V$  to  $+5.25V$  unless otherwise noted.

PARAMETER	MIN.	TYP.	MAX.	UNITS	CONDITIONS
<b>LOGIC INPUTS</b>					
$V_{IL}$ $V_{IH}$	2.0		0.8	Volts Volts	
<b>LOGIC OUTPUTS</b>					
$V_{OL}$ $V_{OH}$	2.4		0.4	Volts Volts	$I_{OUT} = -3.2\text{mA}$ $I_{OUT} = 1.0\text{mA}$
<b>V.28 DRIVER</b>					
<b>DC Parameters</b>					
Outputs					
Open Circuit Voltage			$\pm 15$	Volts	per Figure 1
Loaded Voltage	$\pm 5.0$		$\pm 15$	Volts	per Figure 2
Short-Circuit Current			$\pm 100$	mA	per Figure 4
Power-Off Impedance	300			$\Omega$	per Figure 5
<b>AC Parameters</b>					
Outputs					
Transition Time			1.5	$\mu\text{s}$	per Figure 6; +3V to -3V
Instantaneous Slew Rate			30	V/ $\mu\text{s}$	per Figure 3
Propagation Delay					
$t_{PHL}$	0.5	1	5	$\mu\text{s}$	
$t_{PLH}$	0.5	1	5	$\mu\text{s}$	
Max. Transmission Rate	120	230		kbps	
<b>V.28 RECEIVER</b>					
<b>DC Parameters</b>					
Inputs					
Input Impedance	3		7	k $\Omega$	per Figure 7
Open-Circuit Bias			+2.0	Volts	per Figure 8
HIGH Threshold		1.7	3.0	Volts	
LOW Threshold	0.8	1.2		Volts	
<b>AC Parameters</b>					
Propagation Delay					
$t_{PHL}$	50	100	500	ns	$V_{CC} = +5V$ for AC parameters
$t_{PLH}$	50	100	500	ns	

## ELECTRICAL CHARACTERISTICS

$T_A = +25^\circ\text{C}$  and  $V_{CC} = +4.75\text{V}$  to  $+5.25\text{V}$  unless otherwise noted.

PARAMETER	MIN.	TYP.	MAX.	UNITS	CONDITIONS
<b>V.28 RECEIVER (continued)</b>					
<b>AC Parameters (cont.)</b>					
Max. Transmission Rate	120	230		kbps	
<b>V.10 DRIVER</b>					
<b>DC Parameters</b>					
Outputs					
Open Circuit Voltage	$\pm 4.0$		$\pm 6.0$	Volts	per Figure 9
Test-Terminated Voltage	$0.9V_{OC}$			Volts	per Figure 10
Short-Circuit Current			$\pm 150$	mA	per Figure 11
Power-Off Current			$\pm 100$	$\mu\text{A}$	per Figure 12
<b>AC Parameters</b>					
Outputs					
Transition Time			200	ns	per Figure 10; 10% to 90%
Propagation Delay					
$t_{PHL}$	50	100	500	ns	
$t_{PLH}$	50	100	500	ns	
Max. Transmission Rate	120			kbps	
<b>V.11 DRIVER</b>					
<b>DC Parameters</b>					
Outputs					
Open Circuit Voltage			$\pm 5.0$	Volts	per Figure 14
Test Terminated Voltage	$\pm 2.0$			Volts	per Figure 15
	$0.5V_{OC}$		$0.67V_{OC}$	Volts	
Balance			$\pm 0.4$	Volts	per Figure 15
Offset			+3.0	Volts	per Figure 15
Short-Circuit Current			$\pm 150$	mA	per Figure 16
Power-Off Current			$\pm 100$	$\mu\text{A}$	per Figure 17
<b>AC Parameters</b>					
Outputs					
Transition Time			25	ns	per Figures 19 and 24; 10% to 90%
Propagation Delay					Using $R_L = 100\Omega$ and $C_L = 50\text{pF}$ ;
$t_{PHL}$	50	80	115	ns	per Figures 21 and 24
$t_{PLH}$	50	80	115	ns	per Figures 21 and 24
Differential Skew		20	40	ns	per Figures 21 and 24,
					$t_{SKEW} =  t_{DPLH} - t_{DPHL} $
Max. Transmission Rate	10			Mbps	
<b>V.11 RECEIVER</b>					
<b>DC Parameters</b>					
Inputs					
Common Mode Range	-7		+7	Volts	
Sensitivity			$\pm 0.38$	Volts	

## ELECTRICAL CHARACTERISTICS

$T_A = +25^{\circ}\text{C}$  and  $V_{CC} = +4.75\text{V}$  to  $+5.25\text{V}$  unless otherwise noted.

PARAMETER	MIN.	TYP.	MAX.	UNITS	CONDITIONS
<b>V.11 RECEIVER (continued)</b>					
<b>DC Parameters (cont.)</b>					
Input Current	-3.25		+3.25	mA	per Figure 18 and 20
Input Impedance	4			k $\Omega$	
<b>AC Parameters</b>					
Propagation Delay					<b><math>V_{CC} = +5\text{V}</math> for AC parameters</b> Using $R_L = 100\Omega$ and $C_L = 50\text{pF}$ ; per Figure 21 and 26 per Figure 21 and 26 per Figure 21, $t_{\text{SKEW}} =  t_{\text{PLH}} - t_{\text{PHL}} $
$t_{\text{PHL}}$	80	110	160	ns	
$t_{\text{PLH}}$	80	110	160	ns	
Differential Skew		20		ns	
Max. Transmission Rate	10			Mbps	
<b>POWER REQUIREMENTS</b>					
$V_{CC}$	4.75	5.00	5.25	Volts	All $I_{CC}$ values are with $V_{CC} = +5\text{V}$ $f_{\text{IN}} = 120\text{kbps}$ ; Drivers active & loaded. $f_{\text{IN}} = 2.1\text{Mbps}$ ; Drivers active & loaded. $f_{\text{IN}} = 1.0\text{Mbps}$ ; Drivers active & loaded. $D0 = D1 = 0\text{V}$ , refer to <i>Table 1</i>
$I_{CC}$					
(V.28/RS-232)		35	45	mA	
(V.11/RS-422)		130	150	mA	
(EIA-530/RS-449) (Shutdown)		105 4	130	mA $\mu\text{A}$	
<b>ENVIRONMENTAL AND MECHANICAL</b>					
Operating Temperature Range	0		+70	$^{\circ}\text{C}$	
Storage Temperature Range	-65		+150	$^{\circ}\text{C}$	

## OTHER AC CHARACTERISTICS

$T_A = +25^\circ\text{C}$  and  $V_{CC} = +5.0\text{V}$  unless otherwise noted.

PARAMETER	MIN.	TYP.	MAX.	UNITS	CONDITIONS
<b>DRIVER DELAY TIME BETWEEN ACTIVE MODE AND TRI-STATE MODE</b>					
<b>RS-232/V.28 DRIVERS</b>					
$t_{PZL}$ : Tri-state to Output LOW		0.70	5.0	$\mu\text{s}$	$C_L = 100\text{pF}$ , Fig. 22 & 28 ; $S_1$ closed
$t_{PZH}$ : Tri-state to Output HIGH		0.40	2.0	$\mu\text{s}$	$C_L = 100\text{pF}$ , Fig. 22 & 28 ; $S_2$ closed
$t_{PLZ}$ : Output LOW to Tri-state		0.20	2.0	$\mu\text{s}$	$C_L = 100\text{pF}$ , Fig. 22 & 28 ; $S_1$ closed
$t_{PHZ}$ : Output HIGH to Tri-state		0.40	2.0	$\mu\text{s}$	$C_L = 100\text{pF}$ , Fig. 22 & 28 ; $S_2$ closed
<b>RS-423/V.10 DRIVERS</b>					
$t_{PZL}$ : Tri-state to Output LOW		0.15	2.0	$\mu\text{s}$	$C_L = 100\text{pF}$ , Fig. 22 & 28 ; $S_1$ closed
$t_{PZH}$ : Tri-state to Output HIGH		0.20	2.0	$\mu\text{s}$	$C_L = 100\text{pF}$ , Fig. 22 & 28 ; $S_2$ closed
$t_{PLZ}$ : Output LOW to Tri-state		0.20	2.0	$\mu\text{s}$	$C_L = 100\text{pF}$ , Fig. 22 & 28 ; $S_1$ closed
$t_{PHZ}$ : Output HIGH to Tri-state		0.15	2.0	$\mu\text{s}$	$C_L = 100\text{pF}$ , Fig. 22 & 28 ; $S_2$ closed
<b>RS-422/V.11 DRIVERS</b>					
$t_{PZL}$ : Tri-state to Output LOW		2.80	10.0	$\mu\text{s}$	$C_L = 100\text{pF}$ , Fig. 22 & 25 ; $S_1$ closed
$t_{PZH}$ : Tri-state to Output HIGH		0.10	2.0	$\mu\text{s}$	$C_L = 100\text{pF}$ , Fig. 22 & 25 ; $S_2$ closed
$t_{PLZ}$ : Output LOW to Tri-state		0.10	2.0	$\mu\text{s}$	$C_L = 15\text{pF}$ , Fig. 22 & 25 ; $S_1$ closed
$t_{PHZ}$ : Output HIGH to Tri-state		0.10	2.0	$\mu\text{s}$	$C_L = 15\text{pF}$ , Fig. 22 & 25 ; $S_2$ closed
<b>RECEIVER DELAY TIME BETWEEN ACTIVE MODE AND TRI-STATE MODE</b>					
<b>RS-232/V.28 RECEIVERS</b>					
$t_{PZL}$ : Tri-state to Output LOW		0.12	2.0	$\mu\text{s}$	$C_L = 100\text{pF}$ , Fig. 23 & 27 ; $S_1$ closed
$t_{PZH}$ : Tri-state to Output HIGH		0.10	2.0	$\mu\text{s}$	$C_L = 100\text{pF}$ , Fig. 23 & 27 ; $S_2$ closed
$t_{PLZ}$ : Output LOW to Tri-state		0.10	2.0	$\mu\text{s}$	$C_L = 100\text{pF}$ , Fig. 23 & 27 ; $S_1$ closed
$t_{PHZ}$ : Output HIGH to Tri-state		0.10	2.0	$\mu\text{s}$	$C_L = 100\text{pF}$ , Fig. 23 & 27 ; $S_2$ closed
<b>RS-422/V.11 RECEIVERS</b>					
$t_{PZL}$ : Tri-state to Output LOW		0.10	2.0	$\mu\text{s}$	$C_L = 100\text{pF}$ , Fig. 23 & 27 ; $S_1$ closed
$t_{PZH}$ : Tri-state to Output HIGH		0.10	2.0	$\mu\text{s}$	$C_L = 100\text{pF}$ , Fig. 23 & 27 ; $S_2$ closed
$t_{PLZ}$ : Output LOW to Tri-state		0.10	2.0	$\mu\text{s}$	$C_L = 15\text{pF}$ , Fig. 23 & 27 ; $S_1$ closed
$t_{PHZ}$ : Output HIGH to Tri-state		0.10	2.0	$\mu\text{s}$	$C_L = 15\text{pF}$ , Fig. 23 & 27 ; $S_2$ closed

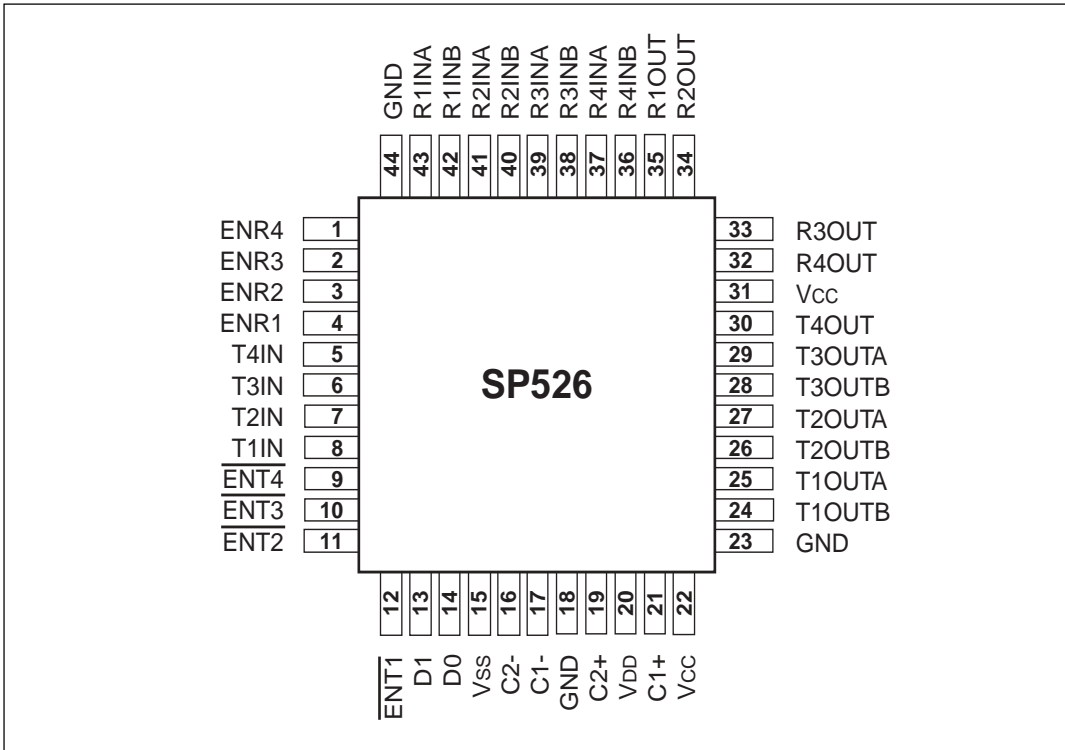

## PIN DESCRIPTION

Pin 1 — ENR4 — Enables receiver 4; active high; TTL input.

Pin 2 — ENR3 — Enables receiver 3; active high; TTL input.

Pin 3 — ENR2 — Enables receiver 2; active high; TTL input.

Pin 4 — ENR1 — Enables receiver 1; active high; TTL input.

Pin 5 — T4IN — TTL input; transmit data source for DRA4 and DRB4 outputs.

Pin 6 — T3IN — TTL input; transmit data source for DRA3 and DRB3 outputs.

Pin 7 — T2IN — TTL input; transmit data source for DRA2 and DRB2 outputs.

Pin 8 — T1IN — TTL input; transmit data source for DRA1 and DRB1 outputs.

Pins 9 —  $\overline{\text{ENT4}}$  — Enables driver 4, active low; TTL input.

Pins 10 —  $\overline{\text{ENT3}}$  — Enables driver 3, active low; TTL input.

Pins 11 —  $\overline{\text{ENT2}}$  — Enables driver 2, active low; TTL input.

Pins 12 —  $\overline{\text{ENT1}}$  — Enables driver 1, active low; TTL input.

Pins 13 — D1 — Transmitter and receiver decode register; configures transmitter and receiver modes; TTL inputs.

Pin 14 — D0 — Transmitter and receiver decode register; configures transmitter and receiver modes; TTL inputs.

Pin 15 —  $V_{SS}$  — -10V Charge Pump Capacitor — Connects from ground to  $V_{SS}$ . Suggested capacitor size is 1.0 $\mu$ F, 16V.

Pin 16 —  $C_2^-$  — Charge Pump Capacitor — Connects from  $C_2^+$  to  $C_2^-$ . Suggested capacitor size is 1.0 $\mu$ F, 16V.

Pin 17 —  $C_1^-$  — Charge Pump Capacitor — Connects from  $C_1^+$  to  $C_1^-$ . Suggested capacitor size is 1.0 $\mu$ F, 16V.

Pin 18 — GND — Ground.

Pin 19 —  $C_2^+$  — Charge Pump Capacitor — Connects from  $C_2^+$  to  $C_2^-$ . Suggested capacitor size is 1.0 $\mu$ F, 16V.

Pin 20 —  $V_{DD}$  — +10V Charge Pump Capacitor — Connects from  $V_{DD}$  to  $V_{CC}$ . Suggested capacitor size is 1.0 $\mu$ F, 16V.

Pin 21 —  $C_1^+$  — Charge Pump Capacitor — Connects from  $C_1^+$  to  $C_1^-$ . Suggested capacitor size is 1.0 $\mu$ F, 16V.

Pin 22 —  $V_{CC}$  — +5V input.

Pin 23 — GND — Ground.

Pin 24 — T1OUTB — Analog Out — Send data, non-inverted; sourced from TIN1.

Pin 25 — T1OUTA — Analog Out — Send data, inverted; sourced from TIN1.

Pin 26 — T2OUTB — Analog Out — Send data, non-inverted; sourced from TIN2.

Pin 27 — T2OUTA — Analog Out — Send data, inverted; sourced from TIN2.

Pin 28 — T3OUTB — Analog Out — Send data, non-inverted; sourced from TIN3.

Pin 29 — T3OUTA — Analog Out — Send data, inverted; sourced from TIN3.

Pin 30 — T4OUT — Analog Out — Send data, inverted; sourced from TIN4.

Pin 31 —  $V_{CC}$  — +5V input.

Pin 32 — R4OUT — TTL output; sourced from RINA4 and RINB4 inputs.

Pin 33 — R3OUT — TTL output; sourced from RINA3 and RINB3 inputs.

Pin 34 — R2OUT — TTL output; sourced from RINA2 and RINB2 inputs.

Pin 35 — R1OUT — TTL output; sourced from RINA1 and RINB1 inputs.

Pin 36 — R4INB — Non-inverted analog input to receiver 4.

Pin 37 — R4INA — Inverted analog input to receiver 4.

Pin 38 — R3INB — Non-inverted analog input to receiver 3.

Pin 39 — R3INA — Inverted analog input to receiver 3.

Pin 40 — R2INB — Non-inverted analog input to receiver 2.

Pin 41 — R2INA — Inverted analog input to receiver 2.

Pin 42 — R1INB — Non-inverted analog input to receiver 1.

Pin 43 — R1INA — Inverted analog input to receiver 1.

Pin 44 — GND — Ground.

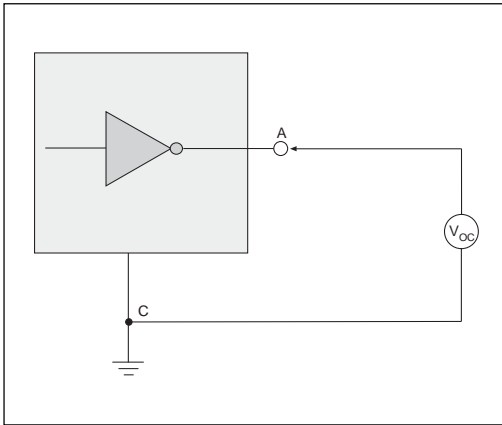

Figure 1. V.28 Driver Output Open Circuit Voltage

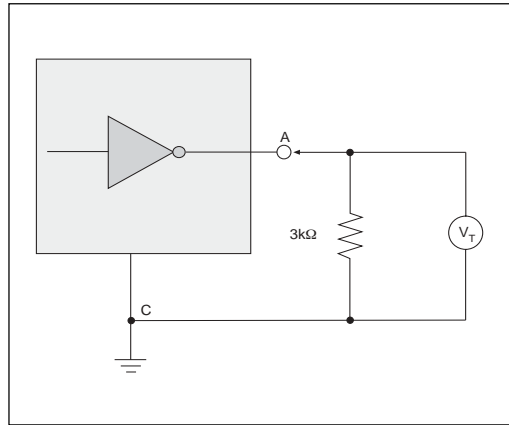

Figure 2. V.28 Driver Output Loaded Voltage

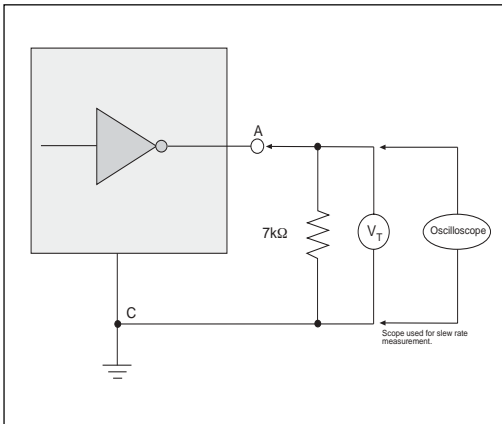

Figure 3. V.28 Driver Output Slew Rate

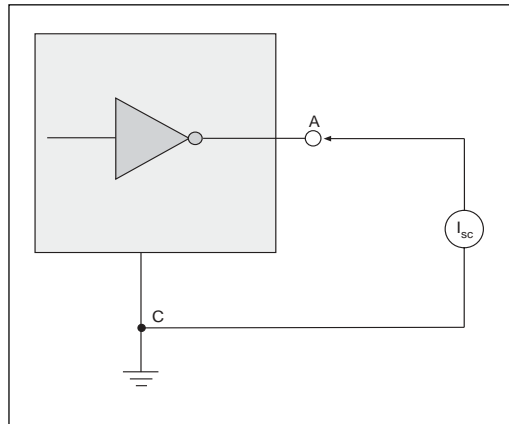

Figure 4. V.28 Driver Output Short-Circuit Current

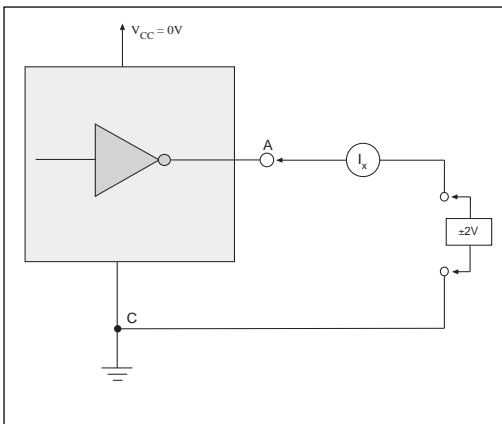

Figure 5. V.28 Driver Output Power-Off Impedance

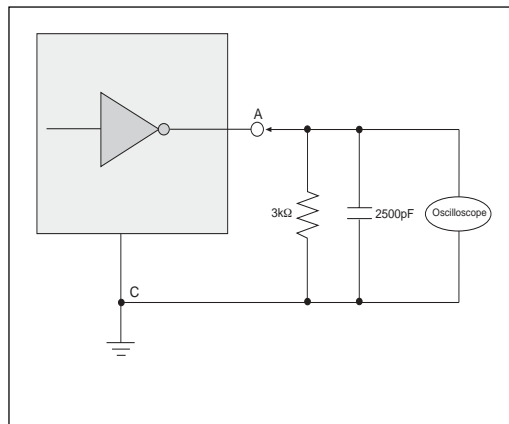

Figure 6. Driver Output Rise/Fall Times



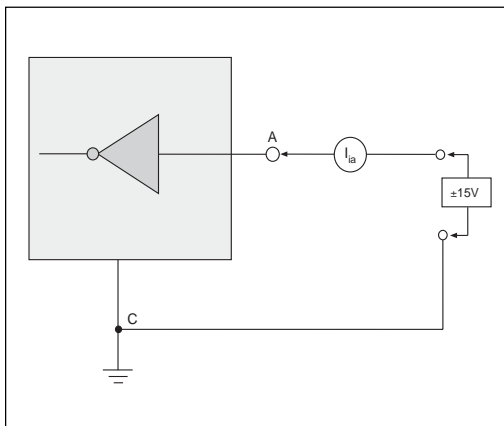

Figure 7. V.28 Receiver Input Impedance

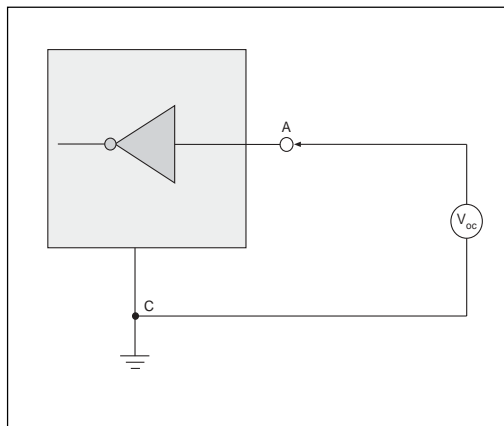

Figure 8. V.28 Receiver Input Open Circuit Bias

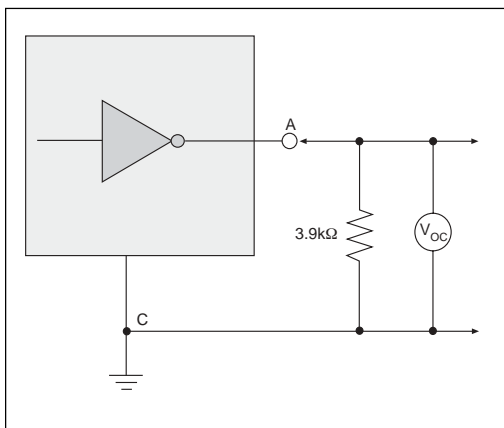

Figure 9. V.10 Driver Output Open-Circuit Voltage

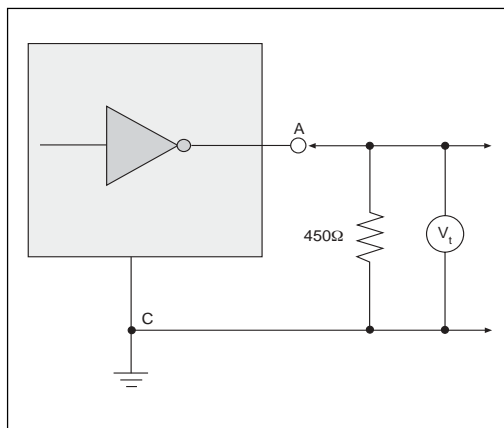

Figure 10. V.10 Driver Output Test Terminated Voltage

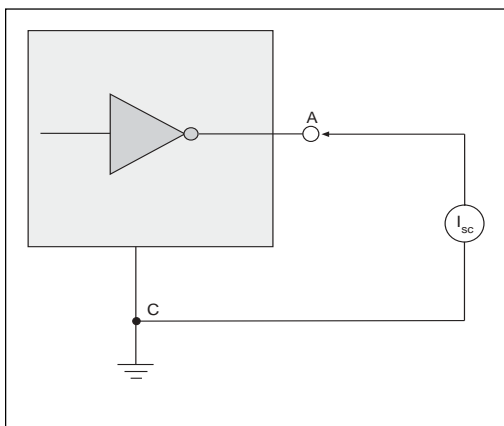

Figure 11. V.10 Driver Output Short-Circuit Current

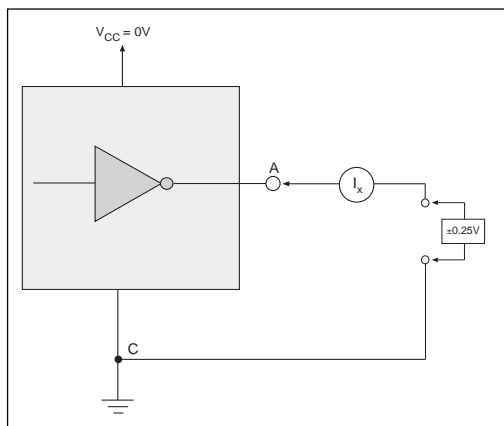

Figure 12. V.10 Driver Output Power-Off Current

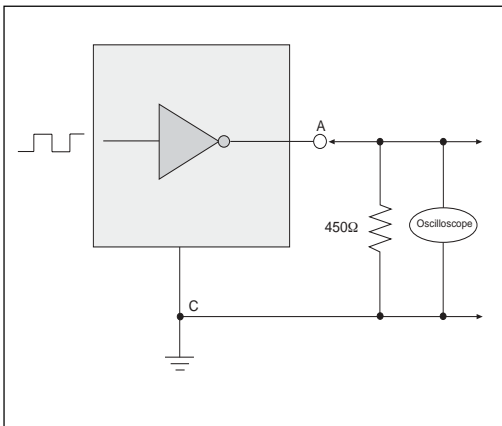

Figure 13. V.10 Driver Output Transition Time

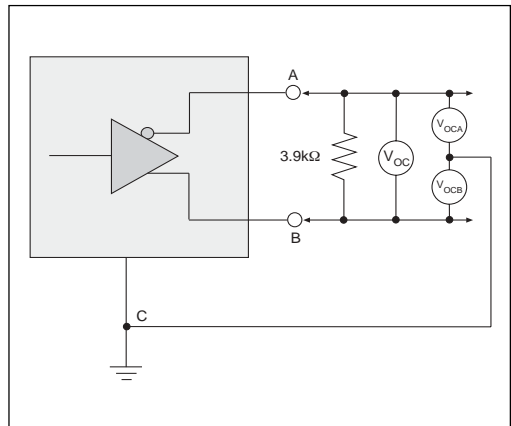

Figure 14. V.11 Driver Output Open-Circuit Voltage

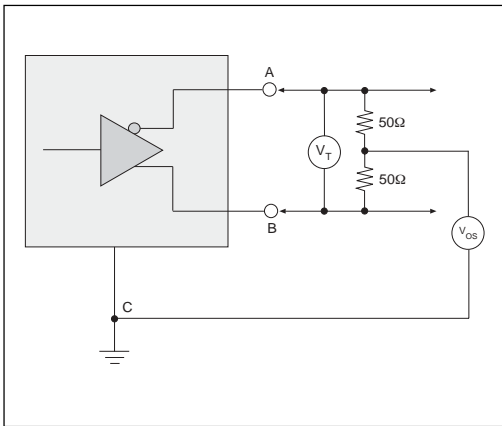

Figure 15. V.11 Driver Output Test Terminated Voltage

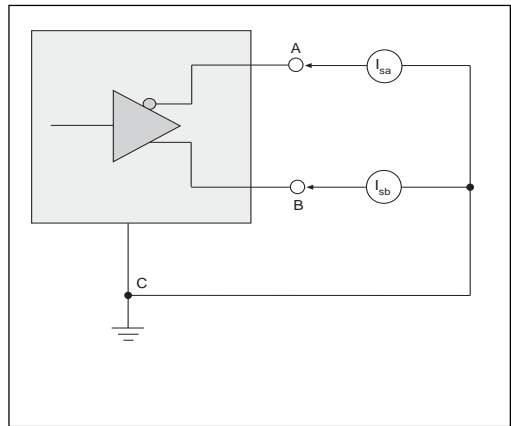

Figure 16. V.11 Driver Output Short-Circuit Current

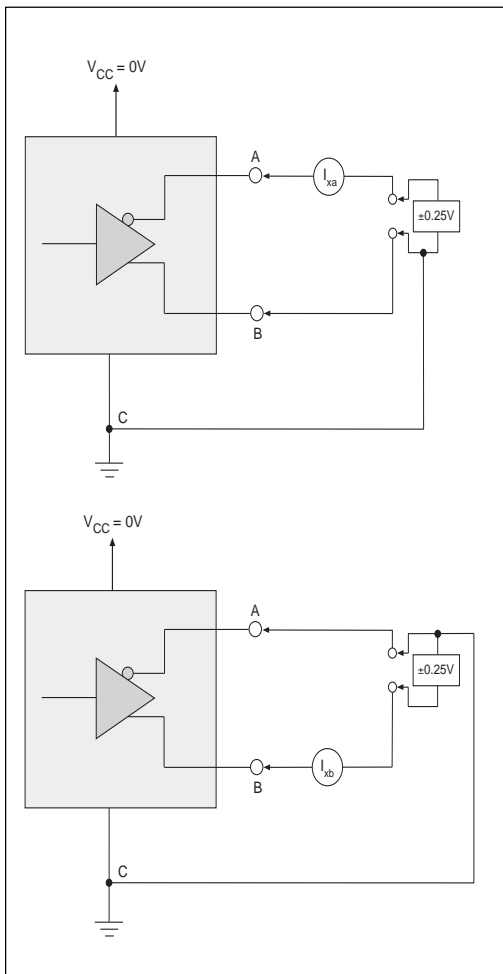

Figure 17. V.11 Driver Output Power-Off Current

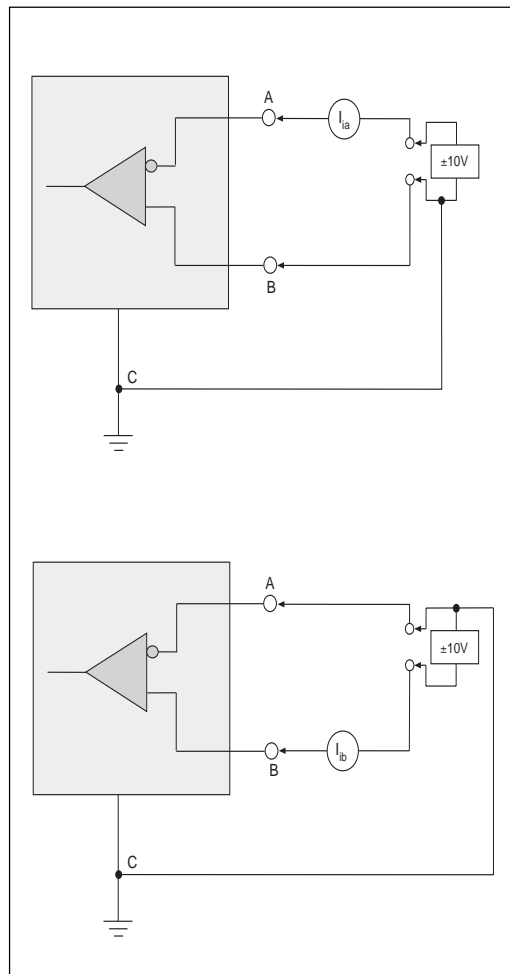

Figure 18. V.11 Receiver Input Current

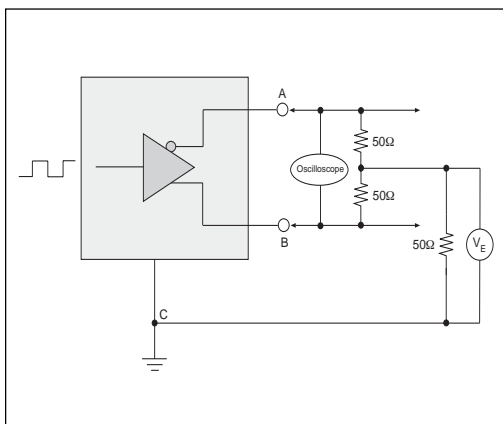

Figure 19. V.11 Driver Output Rise/Fall Time

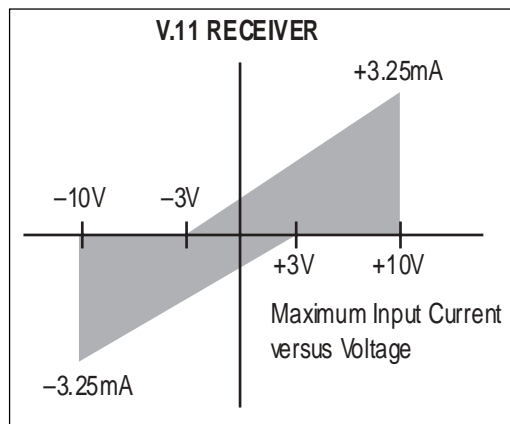

Figure 20. V.11 Receiver Input IV Graph

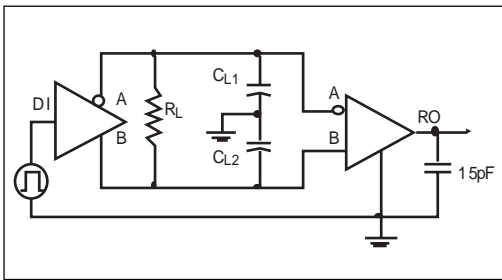

Figure 21. Driver/Receiver Timing Test Circuit

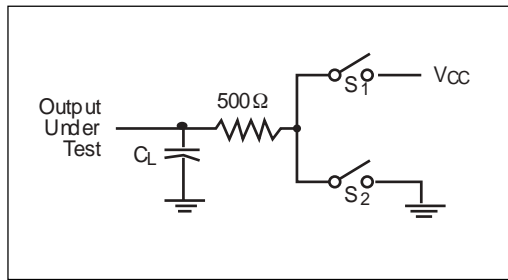

Figure 22. Driver Timing Test Load Circuit

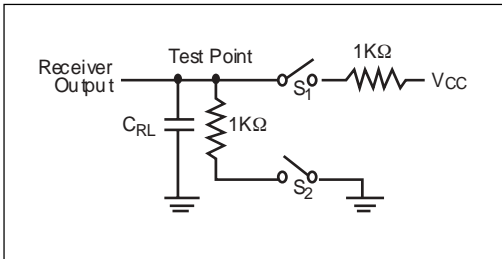

Figure 23. Receiver Timing Test Load Circuit

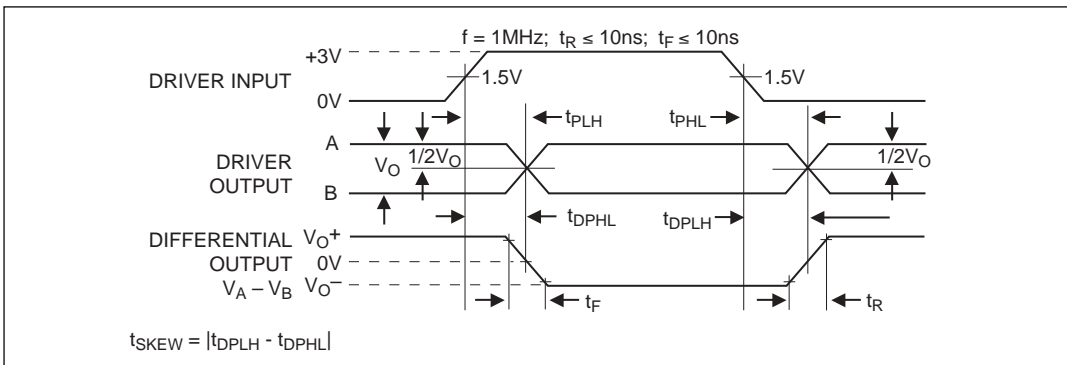

Figure 24. Driver Propagation Delays

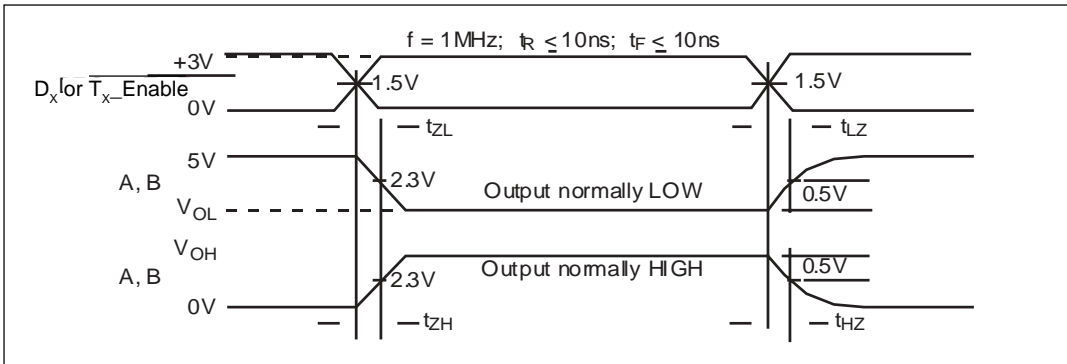

Figure 25. V.11 Driver Enable and Disable Times

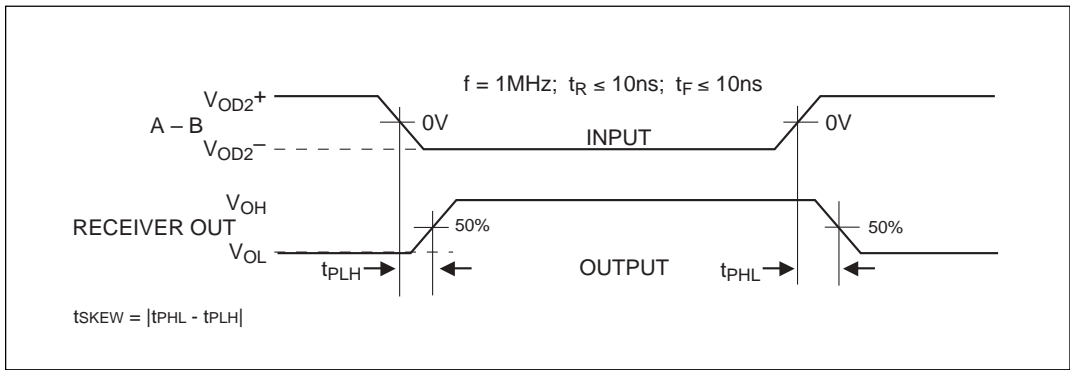

Figure 26. Receiver Propagation Delays

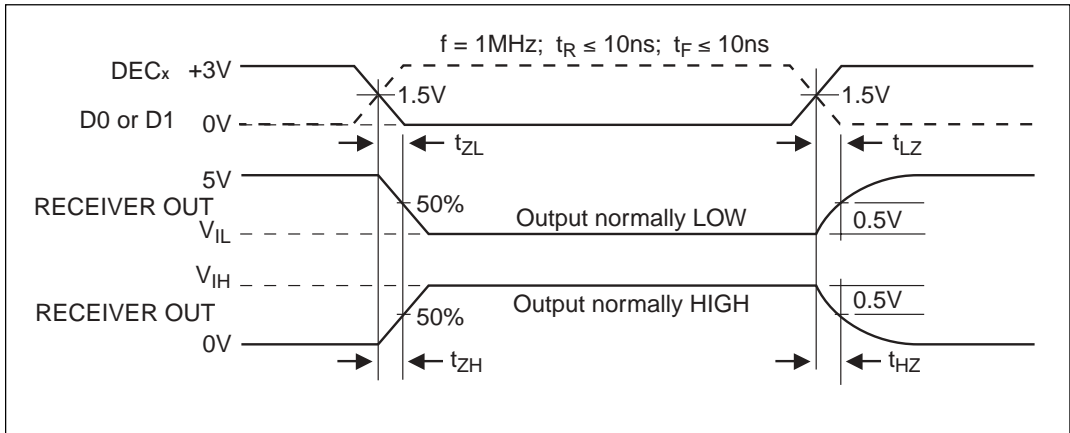

Figure 27. Receiver Enable and Disable Times

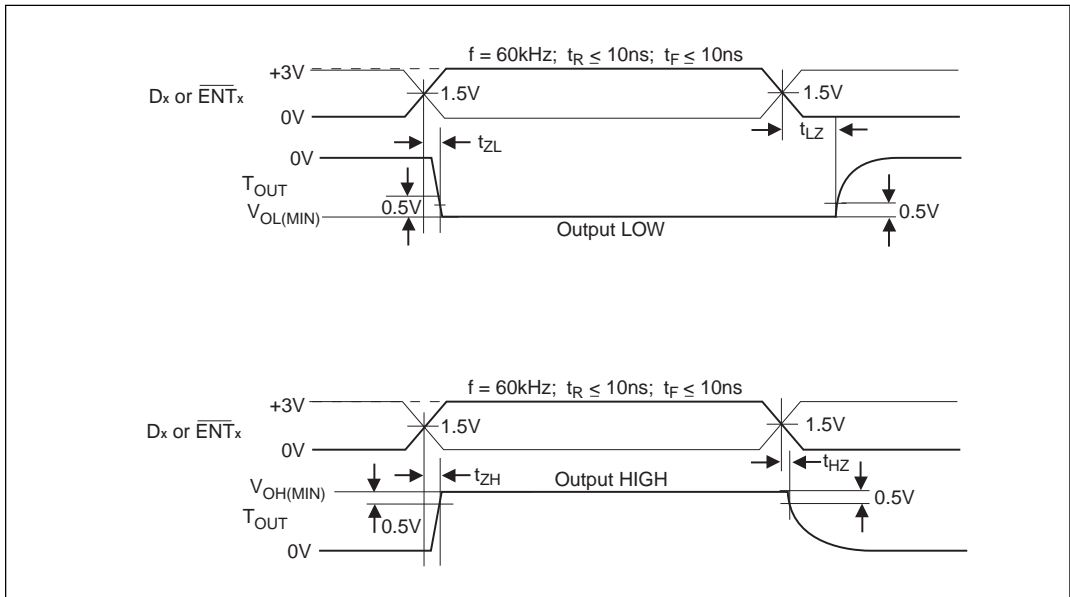

Figure 28. V.28 (RS-232) and V.10 Driver Enable and Disable Times

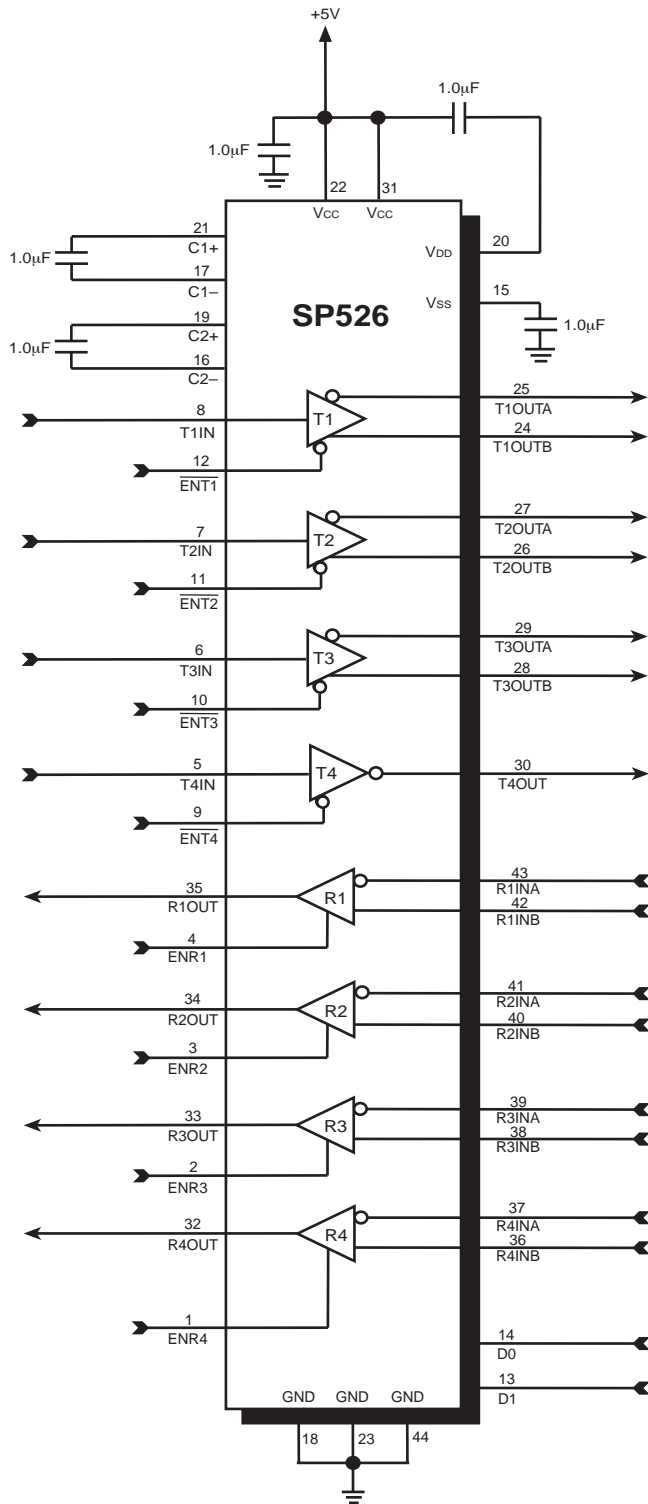

Figure 29. Typical Operating Circuit for the SP526

## FEATURES

The **SP526** contains highly integrated serial transceivers that offer programmability between interface modes through software control. The **SP526** offers the hardware interface modes for RS-232 (V.28), RS-423 (V.10), RS-422 (V.11), and RS-485. The interface mode selection is done via two control pins.

The **SP526** has four drivers, four receivers, and an on-board charge pump that is ideally suited for low-cost wide area network connectivity and other multi-protocol applications. Based on our multi-mode **SP500** family, **Sipex** has allocated specific transceiver cells, or "building blocks," from this product series and created the **SP526**. **Sipex's** "building blocks" concept allows these small transceiver cells to be packaged to offer a simple low-cost solution to networking applications that need only 4 interface modes. For example, an 8-channel applications requiring eight serial transceivers can be achieved implementing two **SP526** devices. The **SP526** can be implemented in series with other devices in our **SP500** family. A 9-channel network application can be achieved implementing the **SP505** which contains seven transceivers in conjunction with the **SP526**.

## THEORY OF OPERATION

The **SP526** device is made up of 1) the drivers, 2) the receivers, and 3) a charge pump.

### Drivers

The **SP526** has four enhanced independent drivers. Control for the mode selection is done via a two-bit control word into D<sub>P0</sub> and D<sub>P1</sub>. The drivers are prearranged such that for each mode of operation, the relative position and functionality of the drivers are set up to accommodate the selected interface mode. As the mode of the drivers is changed, the electrical characteristics will change to support the required signal levels. The mode of each driver in the different interface modes that can be selected is shown in *Table 1*.

There are four basic types of driver circuits — RS-232 (V.28), RS-423 (V.10), RS-422 (V.11), and RS-485.

The RS-232 (V.28) drivers output single-ended signals with a minimum of  $\pm 5V$  (with  $3K\Omega$  &  $2500pF$  loading), and can operate to at least 120Kbps. Since the **SP526** uses a charge pump to generate the RS-232 output rails, the driver outputs will never exceed  $\pm 10V$ .

The RS-423 (V.10) drivers are also single-ended signals which produce open circuit  $V_{OL}$  and  $V_{OH}$  measurements of  $\pm 4.0V$  to  $\pm 6.0V$ . When terminated with a  $450\Omega$  load to ground, the driver output will not deviate more than 10% of the open circuit value. This is in compliance

D1	D0	DRIVERS				RECEIVERS			
		T1	T2	T3	T4	R1	R2	R3	R4
0	0	SHUTDOWN - Tx and Rx Outputs in Tri-State Mode							
0	1	V.11	V.11	V.11	V.10	V.11	V.11	V.11	V.11
1	0	V.11	V.11	V.10	V.10	V.11	V.11	V.11	V.11
1	1	V.28	V.28	V.28	V.28	V.28	V.28	V.28	V.28

*Table 1. SP526 Driver and Receiver Mode Selection with the Control Lines D1 and D0*

of the ITU V.10 specification. The RS-423 drivers are used in RS-449, EIA-530, EIA-530A and V.36 modes as Category II signals from each of their corresponding specifications.

The third and fourth type of drivers are RS-422 (V.11)/RS-485 type differential drivers. Due to the nature of differential signaling, the drivers are more immune to noise as opposed to single-ended transmission methods. The advantage is evident over high speeds and long transmission lines. The strength of the driver outputs can produce differential signals that can maintain RS-485,  $\pm 1.5\text{V}$  differential output levels with a worst case load of  $54\Omega$ . The signal levels and drive capability of these drivers allow the drivers to also support RS-422 (V.11) requirements of  $\pm 2\text{V}$  differential output levels with  $100\Omega$  loads. The driver is designed to operate over a common mode range of  $+7\text{V}$  to  $-7\text{V}$  which follows the V.11 specification. The RS-422 drivers are used in RS-449, EIA-530, EIA-530A and V.36 modes as Category I signals which are used for clock and data. All of the differential drivers can operate to at least 10Mbps.

The drivers also have separate enable pins which simplifies half-duplex configurations for some applications and also provides simpler DTE/DCE flexibility with one integrated circuit. The enable pins will tri-state the drivers when the  $\overline{\text{ENT}}1$ ,  $\overline{\text{ENT}}2$ ,  $\overline{\text{ENT}}3$ , and  $\overline{\text{ENT}}4$  pins are at a logic HIGH ("1"). During tri-stated conditions, the driver outputs will be at a high impedance state.

The driver inputs are both TTL or CMOS compatible. Each driver input should have a pull-down or pull-up resistor so that the output will be at a defined state. Unused driver inputs should have pull-up resistors to  $+5\text{V}$  connected so that the output is at a logic LOW ("0"). Unused driver inputs should not be left floating. For differential drivers, the non-inverting output will be at a logic HIGH ("1"). The typical pull-up resistor value should be  $400\text{k}\Omega$ .

## Receivers

The **SP526** has four independent receivers which can be programmed for the different interface modes. Control for the mode selection is done via a two-bit control word that is the same as the driver control word. Therefore, if the modes for the drivers and receivers are supposed to be identical in the application, the control lines can be tied together.

Like the drivers, the receivers are prearranged for the specific requirements of the synchronous serial interface. As the operating mode of the receivers is changed, the electrical characteristics will change to support the required serial interface protocols of the receivers. *Table 1* shows the mode of each receiver in the different interface modes that can be selected.

There are two basic types of receiver circuits — RS-232 (V.28) and RS-422 (V.11).

The RS-232 (V.28) receiver is single-ended and accepts RS-232 signals from the RS-232 driver. The RS-232 receiver has an operating voltage range of  $\pm 15\text{V}$  and can receive signals down to  $\pm 3\text{V}$ . The input sensitivity complies with RS-232 and V.28 at  $\pm 3\text{V}$ . The input impedance is  $3\text{k}\Omega$  to  $7\text{k}\Omega$  in accordance to RS-232 and V.28. The receiver output produces a TTL/CMOS signal with a  $+2.4\text{V}$  minimum for a logic "1" and a  $+0.8\text{V}$  maximum for a logic "0". RS-232(V.28) receivers can be used in RS-232 mode for data, clock or control signals. They are also used in V.35 mode for control line signals: CTS, DSR, LL, and RL. The RS-232 receivers can operate to at least 120kbps.



The third type of receiver is a differential which supports RS-422/V.11 signals. This receiver has a typical input impedance of  $10k\Omega$  and a differential threshold of  $\pm 0.3V$ , which complies with the RS-422/V.11 specifications. Since the characteristics of the RS-422 (V.11) receivers are actually subsets of RS-485, the RS-422/V.11 receivers can accept RS-485 signals. However, these receivers cannot support 32 transceivers on the signal bus due to the lower input impedance as specified in the RS-485 specifications. V.11 receivers are used in RS-422, RS-449, EIA-530, EIA-530A and V.36 as Category I signals for receiving clock, data, and some control line signals not covered by Category II V.10 circuits. The differential receivers can receive signals up to at least 10Mbps.

All four receivers include an enable line for tri-state of the receiver output allowing convenient half-duplex configurations. When the enable lines are at a logic LOW ("0") active, the receiver outputs are high impedance and will be at approximately  $10k\Omega$  during tri-state.

All receivers include a fail-safe feature that outputs a logic high when the receiver inputs are open. For single-ended RS-232 receivers, there are internal  $5k\Omega$  pull-down resistors on the inputs which produces a logic high ("1") at the receiver outputs. The single-ended RS-423 receivers produce a logic LOW ("0") on the output when the inputs are open. This is due to a pull-up device connected to the input. The differential receivers have the same internal pull-up device on the non-inverting input which produces a logic HIGH ("1") at the receiver output.

## Charge Pump

The charge pump is a **Sipex**-patented design (U.S. 5,306,954) and uses a unique approach compared to older less-efficient designs. The charge pump still requires four external capacitors, but uses a four-phase voltage shifting technique to attain symmetrical 10V power supplies. There is a free-running oscillator that controls the four phases of the voltage shifting. A description of each phase follows.

### Phase 1

—  $V_{SS}$  charge storage — During this phase of the clock cycle, the positive side of capacitors  $C_1$  and  $C_2$  are initially charged to  $+5V$ .  $C_1^+$  is then switched to ground and the charge in  $C_1^-$  is transferred to  $C_2^-$ . Since  $C_2^+$  is connected to  $+5V$ , the voltage potential across capacitor  $C_2$  is now  $10V$ .

### Phase 2

—  $V_{SS}$  transfer — Phase two of the clock connects the negative terminal of  $C_2$  to the  $V_{SS}$  storage capacitor and the positive terminal of  $C_2$  to ground, and transfers the generated  $-10V$  to  $C_3$ . Simultaneously, the positive side of capacitor  $C_1$  is switched to  $+5V$  and the negative side is connected to ground.

### Phase 3

—  $V_{DD}$  charge storage — The third phase of the clock is identical to the first phase — the charge transferred in  $C_1$  produces  $-5V$  in the negative terminal of  $C_1$ , which is applied to the negative side of capacitor  $C_2$ . Since  $C_2^+$  is at  $+5V$ , the voltage potential across  $C_2$  is  $10V$ .

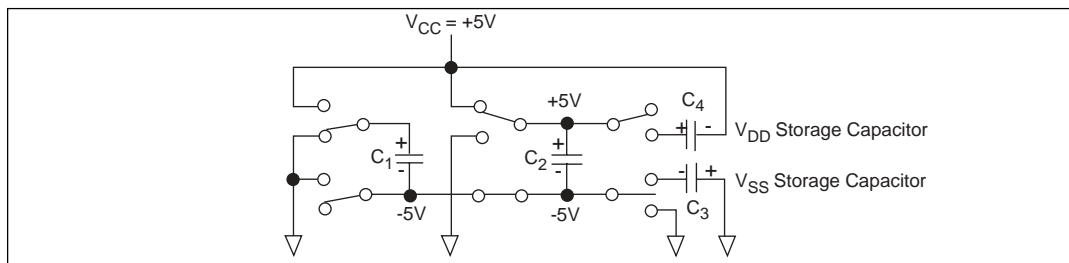

Figure 30. Charge Pump — Phase 1

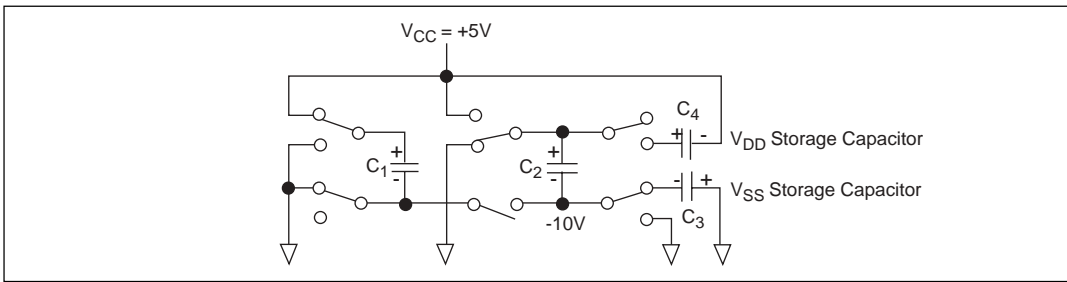

Figure 31. Charge Pump — Phase 2

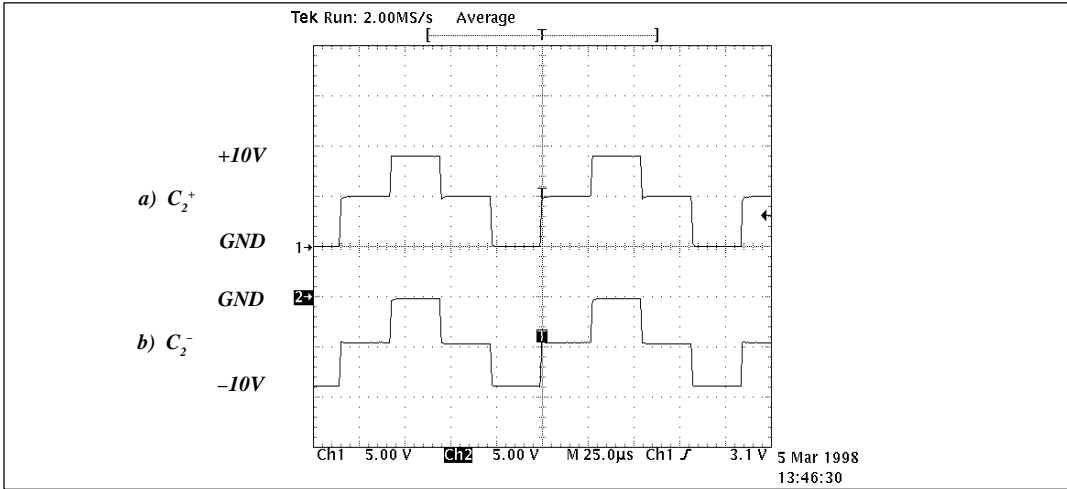

Figure 32. Charge Pump Waveforms

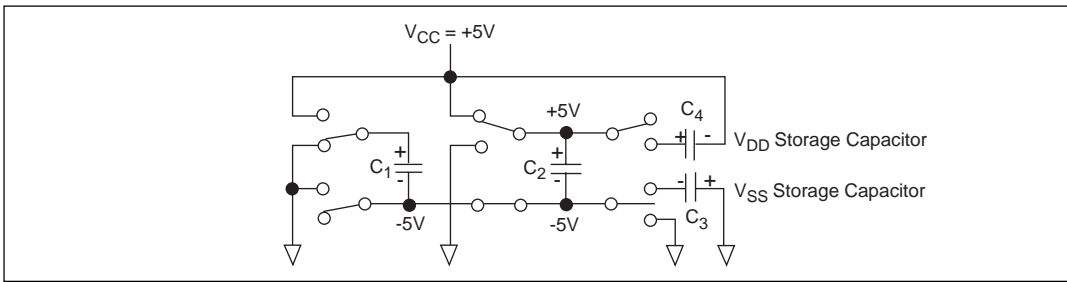

Figure 33. Charge Pump — Phase 3

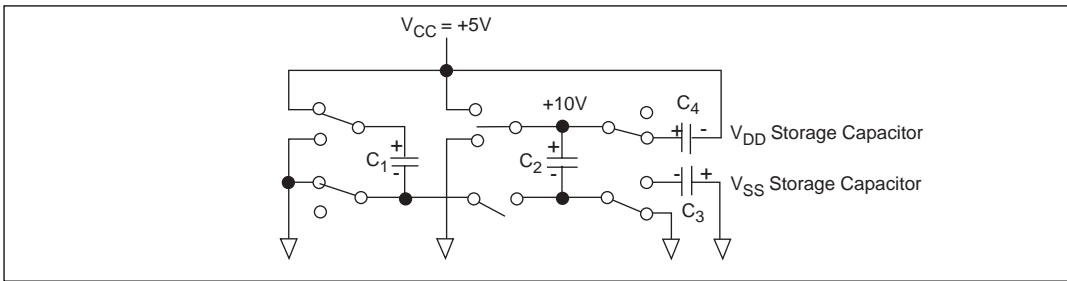

Figure 34. Charge Pump — Phase 4

## Phase 4

—  $V_{DD}$  transfer — The fourth phase of the clock connects the negative terminal of  $C_2$  to ground, and transfers the generated 10V across  $C_2$  to  $C_4$ , the  $V_{DD}$  storage capacitor. Again, simultaneously with this, the positive side of capacitor  $C_1$  is switched to +5V and the negative side is connected to ground, and the cycle begins again.

Since both  $V^+$  and  $V^-$  are separately generated from  $V_{CC}$ ; in a no-load condition  $V^+$  and  $V^-$  will be symmetrical. Older charge pump approaches that generate  $V^-$  from  $V^+$  will show a decrease in the magnitude of  $V^-$  compared to  $V^+$  due to the inherent inefficiencies in the design.

The clock rate for the charge pump typically operates at 15kHz. The external capacitors can be as low as 1.0 $\mu$ F with a 16V breakdown voltage rating.

## ESD Tolerance

The **SP526** device incorporates ruggedized ESD cells on all driver output and receiver input pins. The ESD structure is improved over our previous family for more rugged applications and environments sensitive to electro-static discharges and associated transients. The improved ESD tolerance is at least  $\pm 15$ kV without damage nor latch-up.

There are different methods of ESD testing applied:

- a) MIL-STD-883, Method 3015.7
- b) IEC1000-4-2 Air-Discharge
- c) IEC1000-4-2 Direct Contact

The Human Body Model has been the generally accepted ESD testing method for semiconductors. This method is also specified in MIL-STD-883, Method 3015.7 for ESD testing. The premise of this ESD test is to simulate the human body's potential to store electro-static energy and discharge it to an integrated circuit. The simulation is performed by using a test model as shown in *Figure 35*. This method will test the IC's capability to withstand an ESD transient during normal handling such as in manufacturing areas where the ICs tend to be handled frequently.

The IEC-1000-4-2, formerly IEC801-2, is generally used for testing ESD on equipment and systems. For system manufacturers, they must guarantee a certain amount of ESD protection since the system itself is exposed to the outside environment and human presence. The premise with IEC1000-4-2 is that the system is required to withstand an amount of static electricity when ESD is applied to points and surfaces of the equipment that are accessible to personnel during normal usage. The transceiver IC receives most

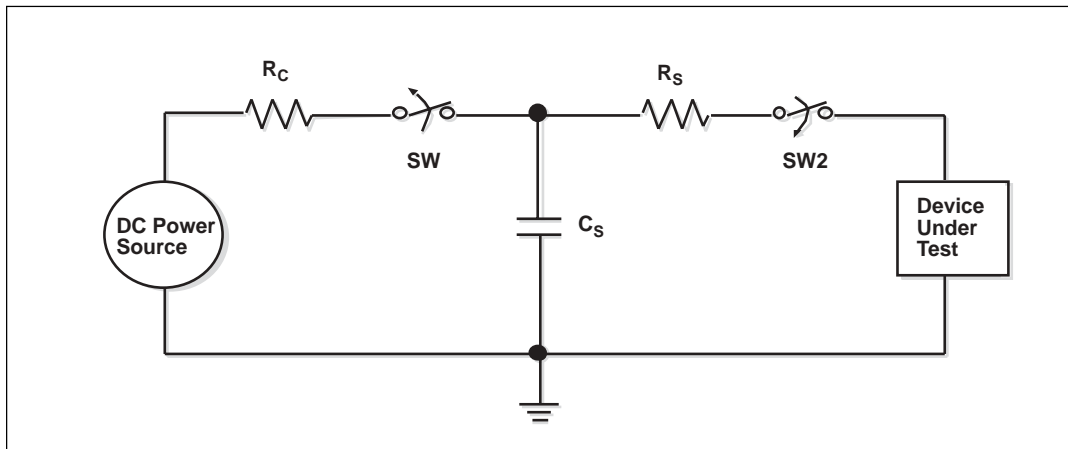

*Figure 35. ESD Test Circuit for Human Body Model*

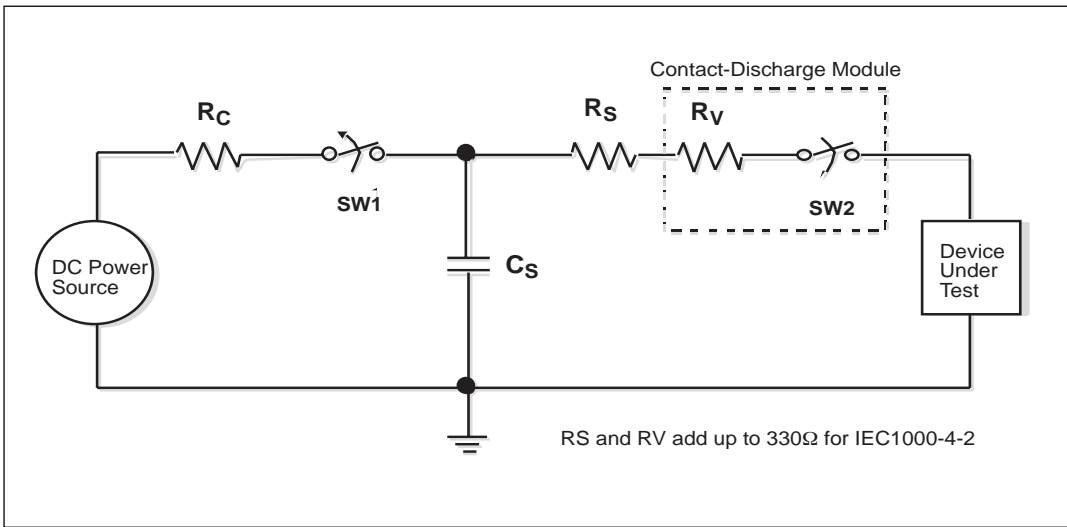

Figure 36. ESD Test Circuit for IEC1000-4-2

of the ESD current when the ESD source is applied to the connector pins. The test circuit for IEC1000-4-2 is shown on Figure 36. There are two methods within IEC1000-4-2, the Air Discharge method and the Contact Discharge method.

With the Air Discharge Method, an ESD voltage is applied to the equipment under test (EUT) through air. This simulates an electrically charged person ready to connect a cable onto the rear of the system only to find an unpleasant zap just before the person touches the back panel. The high energy potential on the person discharges through an arcing path to the rear panel of the system before he or she even touches the system. This energy, whether discharged directly or through air, is predominantly a function of the discharge current rather than the discharge voltage. Variables with an air discharge such as approach speed of the object carrying the ESD

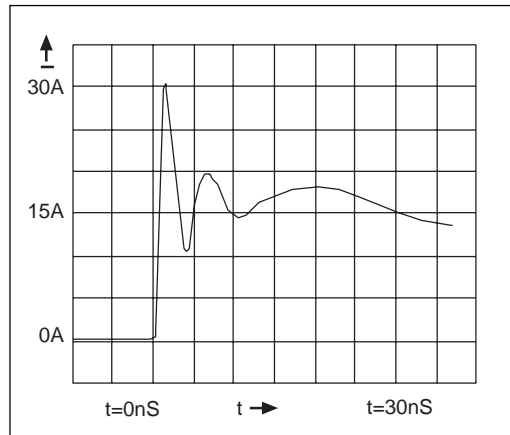

Figure 37. ESD Test Waveform for IEC1000-4-2

Device Pin Tested	Human Body Model	IEC1000-4-2		
		Air Discharge	Direct Contact	Level
Driver Outputs	±15kV	±15kV	±8kV	4
Receiver Inputs	±15kV	±15kV	±8kV	4

Table 2. Transceiver ESD Tolerance Levels

potential to the system and humidity will tend to change the discharge current. For example, the rise time of the discharge current varies with the approach speed.

The Contact Discharge Method applies the ESD current directly to the EUT. This method was devised to reduce the unpredictability of the ESD arc. The discharge current rise time is constant since the energy is directly transferred without the air-gap arc. In situations such as hand held systems, the ESD charge can be directly discharged to the equipment from a person already holding the equipment. The current is transferred on to the keypad or the serial port of the equipment directly and then travels through the PCB and finally to the IC.

The circuit models in *Figures 35* and *36* represent the typical ESD testing circuits used for all three methods. The  $C_S$  is initially charged with the DC power supply when the first switch (SW1) is on. Now that the capacitor is charged, the second switch (SW2) is on while SW1 switches off. The voltage stored in the capacitor is then applied through  $R_S$ , the current limiting resistor, onto the device under test (DUT). In ESD tests, the SW2 switch is pulsed so that the device under test receives a duration of voltage.

For the Human Body Model, the current limiting resistor ( $R_S$ ) and the source capacitor ( $C_S$ ) are  $1.5k\Omega$  and  $100pF$ , respectively. For IEC-1000-4-2, the current limiting resistor ( $R_S$ ) and the source capacitor ( $C_S$ ) are  $330\Omega$  and  $150pF$ , respectively.

The higher  $C_S$  value and lower  $R_S$  value in the IEC1000-4-2 model are more stringent than the Human Body Model. The larger storage capacitor injects a higher voltage to the test point when SW2 is switched on. The lower current limiting resistor increases the current charge onto the test point.

## NET1/NET2 European Compliancy

As with all of **Sipex's** previous multi-protocol serial transceiver ICs, the drivers and receivers have been designed to meet all the requirements to NET1/NET2. The **SP526** is also tested and adheres to all the NET1/2 physical layer testing and the ITU Series V specifications. Please note that although the **SP526**, as with its predecessors, adheres to NET1/2 testing, any complex or unusual configuration should be double-checked to ensure NET compliance. Consult the factory for details.

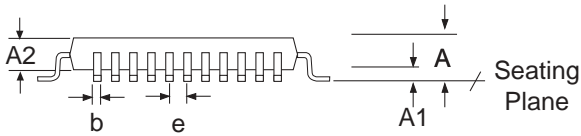
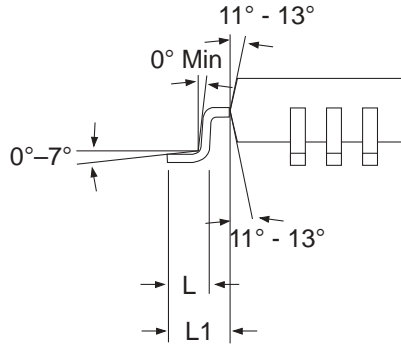
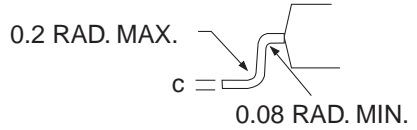
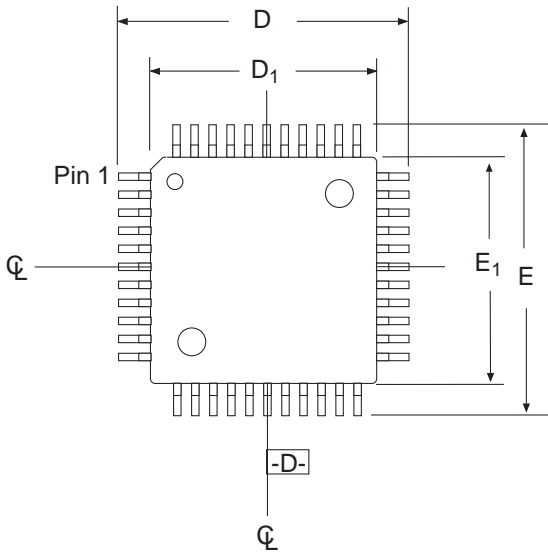

DIMENSIONS Minimum/Maximum (mm)	44-PIN LQFP JEDEC MS-026 (BCB) Variation		
	MIN	NOM	MAX
A			1.60
A1	0.05		0.15
A2	1.35	1.40	1.45
b	0.30	0.37	0.50
D	12.00 BSC		
D1	10.00 BSC		
e	0.80 BSC		
E	12.00 BSC		
E1	10.00 BSC		
N	44		

COMMON DIMENSIONS			
SYMBOL	MIN	NOM	MAX
c	0.11		23.00
L	0.73	0.88	1.03
L1	0.25 BASIC		

## 44 PIN LQFP

## ORDERING INFORMATION

Part Number	Temperature Range	Package Types
SP526CF .....	0°C to +70°C .....	44-pin JEDEC LQFP

Please consult the factory for pricing and availability on a Tape-On-Reel option.

Available in lead free packaging. To order add "-L" suffix to part number.

Example: SP526CF = standard; SP526CF-L = lead free

## REVISION HISTORY

DATE	REVISION	DESCRIPTION
1/27/04	A	Implemented tracking revision.
7/7/04	B	Available in LQFP package.



ANALOG EXCELLENCE

### Sipex Corporation

#### Headquarters and Sales Office

233 South Hillview Drive  
Milpitas, CA 95035  
TEL: (408) 934-7500  
FAX: (408) 935-7600

#### Sales Office

22 Linnell Circle  
Billerica, MA 01821  
TEL: (978) 667-8700  
FAX: (978) 670-9001  
e-mail: sales@sipex.com

Sipex Corporation reserves the right to make changes to any products described herein. Sipex does not assume any liability arising out of the application or use of any product or circuit described herein; neither does it convey any license under its patent rights nor the rights of others.