



STBV32

HIGH VOLTAGE FAST-SWITCHING NPN POWER TRANSISTOR

- n HIGH VOLTAGE CAPABILITY
- n LOW SPREAD OF DYNAMIC PARAMETERS
- n MINIMUM LOT-TO-LOT SPREAD FOR RELIABLE OPERATION
- n VERY HIGH SWITCHING SPEED

APPLICATIONS

- n COMPACT FLUORESCENT LAMPS (CFLS)

DESCRIPTION

The device is manufactured using High Voltage Multi Epitaxial Planar technology for high switching speeds and high voltage capability. It uses a Cellular Emitter structure with planar edge termination to enhance switching speeds while maintaining the wide RBSOA.

The STBV series is designed for use in Compact Fluorescent Lamps.

Figure 1: Package

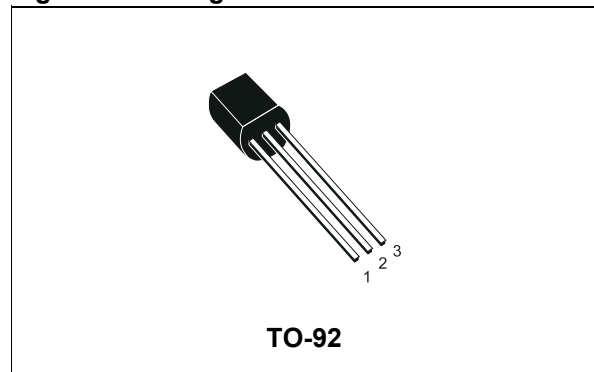

Figure 2: Internal Schematic Diagram

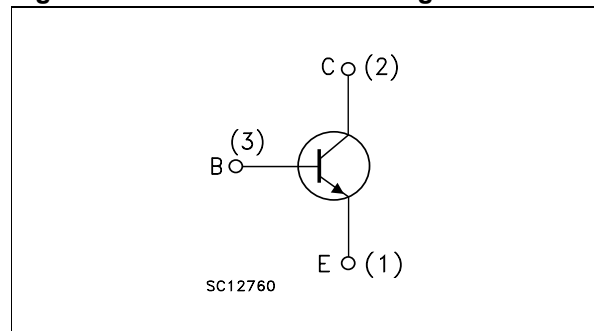

Table 1: Order Codes

Part Number	Marking	Package	Packaging
STBV32	BV32	TO-92	Bulk
STBV32-AP	BV32	TO-92	Ammopack

Table 2: Absolute Maximum Ratings

Symbol	Parameter	Value	Unit
V_{CES}	Collector-Emitter Voltage ($V_{BE} = 0$)	700	V
V_{CEO}	Collector-Emitter Voltage ($I_B = 0$)	400	V
V_{EBO}	Emitter-Base Voltage ($I_C = 0$, $I_B = 0.5$ A, $t_p < 10$ ms)	$V_{(BR)EBO}$	V
I_C	Collector Current ($f \geq 100$ Hz, duty-cycle ≤ 50 %, $T_C = 25$ °C)	1.5	A
I_{CM}	Collector Peak Current ($t_p < 5$ ms)	3	A
I_B	Base Current	0.5	A
I_{BM}	Base Peak Current ($t_p < 5$ ms)	1.5	A
P_{tot}	Total Dissipation at $T_C = 25$ °C	1.5	W

STBV32

Symbol	Parameter	Value	Unit
T_{stg}	Storage Temperature	-65 to 150	°C
T_J	Max. Operating Junction Temperature	150	°C

Table 3: Thermal Data

$R_{thj-case}$	Thermal Resistance Junction-case	Max	83.3	°C/W
$R_{thj-amb}$	Thermal Resistance Junction-Ambient	Max	112	°C/W

Table 4: Electrical Characteristics ($T_{case} = 25\text{ °C}$ unless otherwise specified)

Symbol	Parameter	Test Conditions	Min.	Typ.	Max.	Unit
I_{CEV}	Collector Cut-off Current ($V_{BE} = -1.5\text{ V}$)	$V_{CE} = 700\text{ V}$ $V_{CE} = 700\text{ V}$ $T_J = 125\text{ °C}$			1 5	mA mA
$V_{(BR)EBO}$	Emitter-Base Breakdown Voltage ($I_C = 0$)	$I_E = 10\text{ mA}$	9		18	V
$V_{CEO(sus)}^*$	Collector-Emitter Sustaining Voltage ($I_B = 0$)	$I_C = 10\text{ mA}$	400			V
$V_{CE(sat)}^*$	Collector-Emitter Saturation Voltage	$I_C = 0.5\text{ A}$ $I_B = 100\text{ mA}$ $I_C = 1\text{ A}$ $I_B = 250\text{ mA}$ $I_C = 1.5\text{ A}$ $I_B = 500\text{ mA}$			0.5 1 1.5	V V V
$V_{BE(sat)}^*$	Base-Emitter Saturation Voltage	$I_C = 0.5\text{ A}$ $I_B = 100\text{ mA}$ $I_C = 1\text{ A}$ $I_B = 250\text{ mA}$			1.0 1.2	V V
h_{FE}	DC Current Gain	$I_C = 0.5\text{ A}$ $V_{CE} = 2\text{ V}$ $I_C = 1\text{ A}$ $V_{CE} = 2\text{ V}$	8 5		35 25	
t_r t_s t_f	RESISTIVE LOAD Rise Time Storage Time Fall Time	$I_C = 1\text{ A}$ $V_{CC} = 125\text{ V}$ $I_{B1} = -I_{B2} = 200\text{ mA}$ $t_p = 25\text{ }\mu\text{s}$ (see figure 12)			1 4 0.7	μs μs μs
t_s	INDUCTIVE LOAD Storage Time	$I_C = 1\text{ A}$ $V_{clamp} = 300\text{ V}$ $I_{B1} = 200\text{ mA}$ $V_{BE(off)} = -5\text{ V}$ $L = 50\text{ mH}$ $R_{BB} = 0$ (see figure 13)		0.8		μs

* Pulsed: Pulsed duration = 300 μs , duty cycle $\leq 1.5\%$.

Figure 3: Safe Operating Area

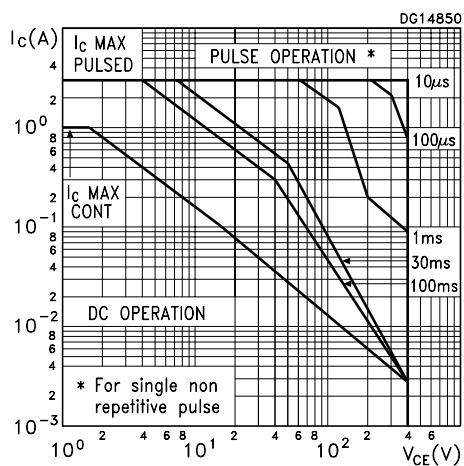

Figure 4: Output Characteristics

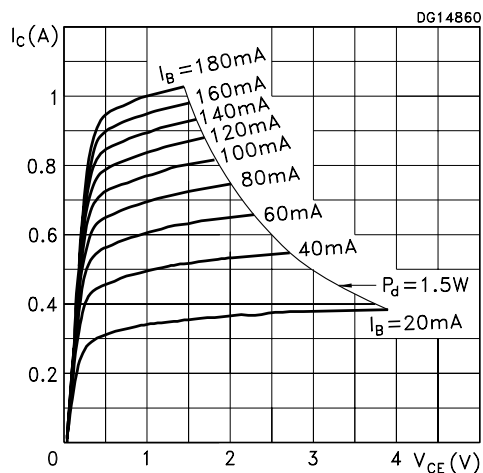

Figure 5: Base-Emitter Saturation Voltage

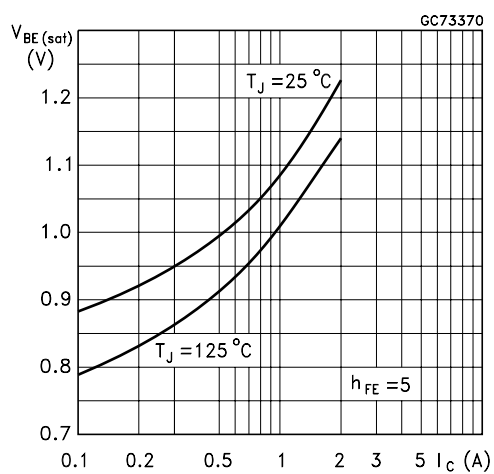

Figure 6: Derating Curve

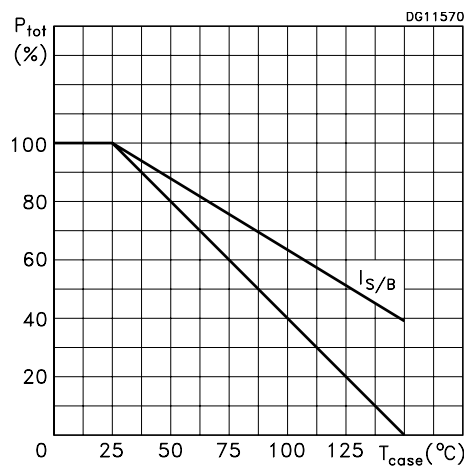

Figure 7: Collector-Emitter Saturation Voltage

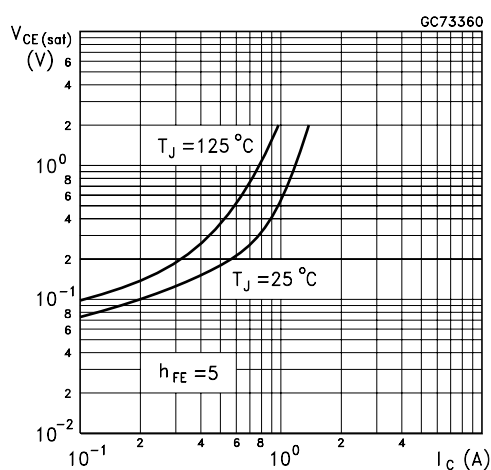

Figure 8: DC Current Gain

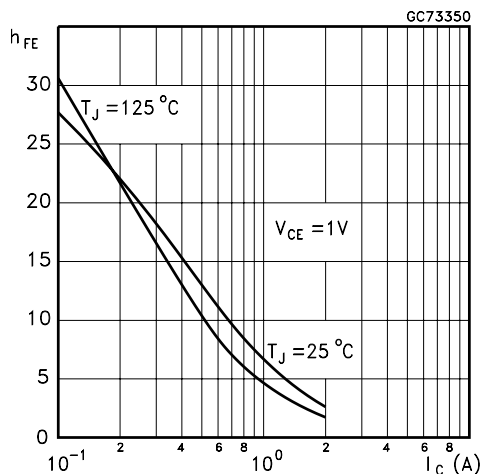

Figure 9: DC Current Gain

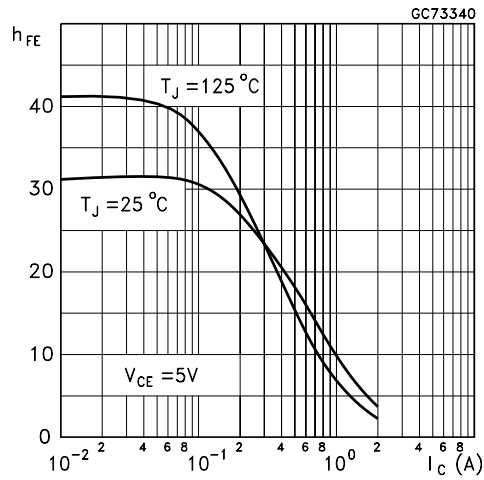

Figure 10: Reverse Biased Operating Area

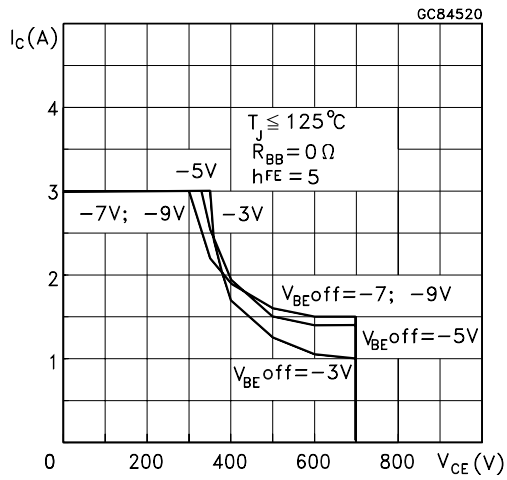

Figure 11: Inductive Load Switching Times

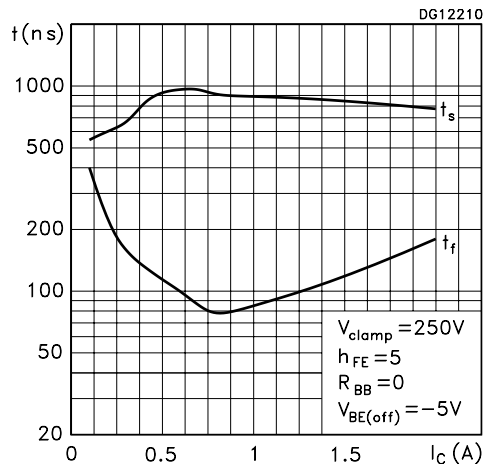

Figure 12: Resistive Load Switching Test Circuit

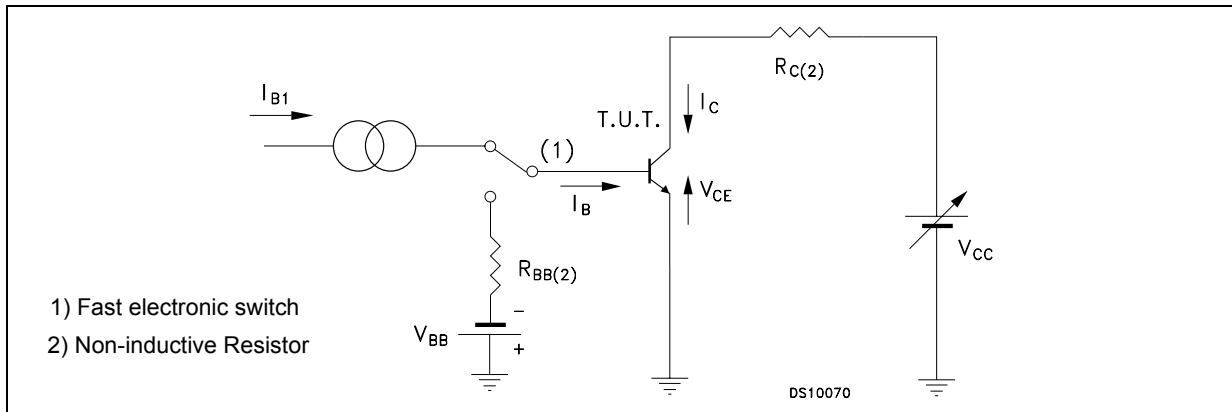
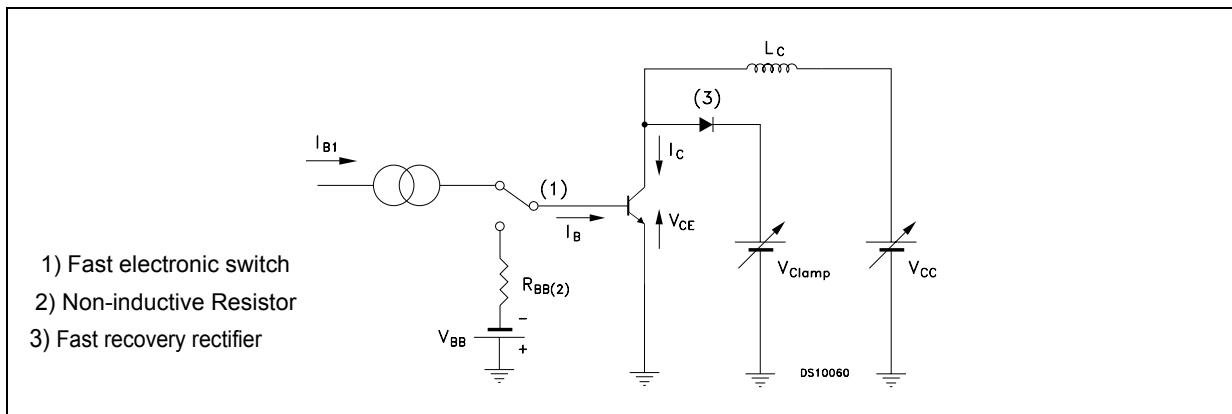
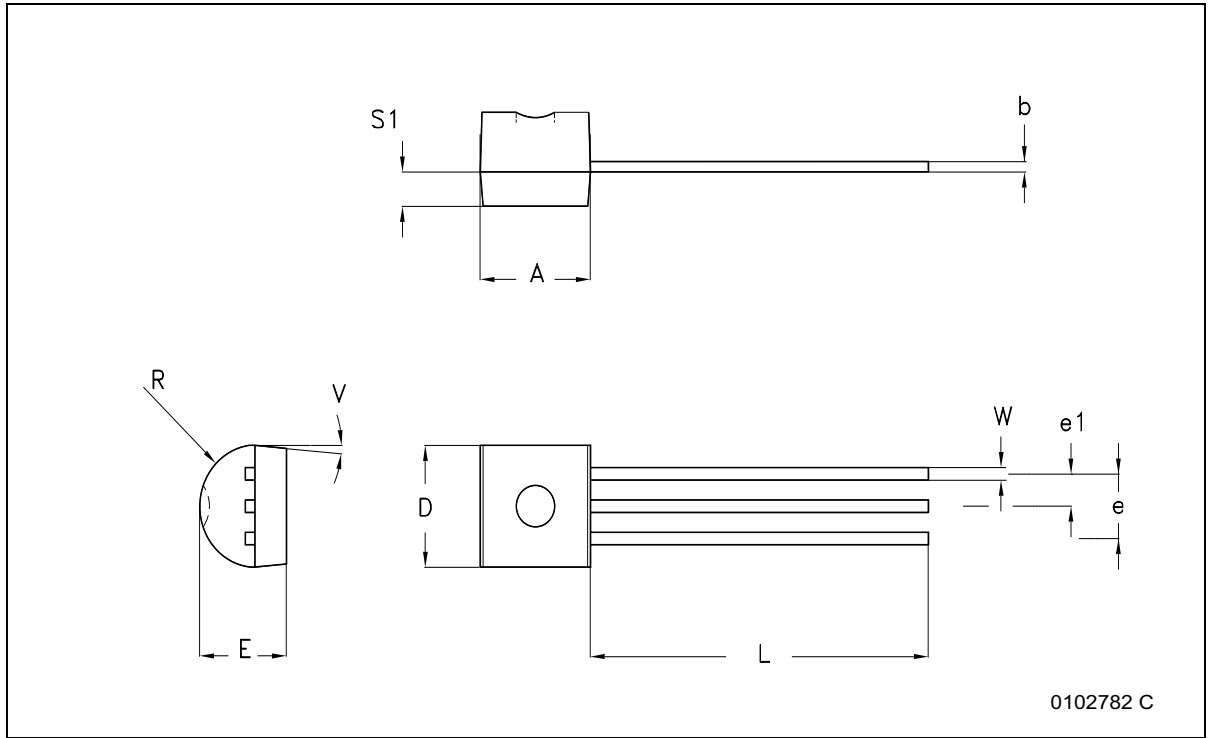

Table 13: Inductive Load Switching Test Circuit



TO-92 BULK SHIPMENT MECHANICAL DATA

DIM.	mm.		
	MIN.	TYP	MAX.
A	4.32		4.95
b	0.36		0.51
D	4.45		4.95
E	3.30		3.94
e	2.41		2.67
e1	1.14		1.40
L	12.70		15.49
R	2.16		2.41
S1	0.92		1.52
W	0.41		0.56
V		5°	



TO-92 AMMOPACK SHIPMENT (Suffix"-AP") MECHANICAL DATA

DIM.	mm.		
	MIN.	TYP	MAX.
A1			4.80
T			3.80
T1			1.60
T2			2.30
d			0.48
P0	12.50	12.70	12.90
P2	5.65	6.35	7.05
F1,F2	2.44	2.54	2.94
delta H	-2.00		2.00
W	17.50	18.00	19.00
W0	5.70	6.00	6.30
W1	8.50	9.00	9.25
W2			0.50
H	18.50		20.50
H0	15.50	16.00	16.50
H1			25.00
D0	3.80	4.00	4.20
t			0.90
L			11.00
I1	3.00		
delta P	-1.00		1.00

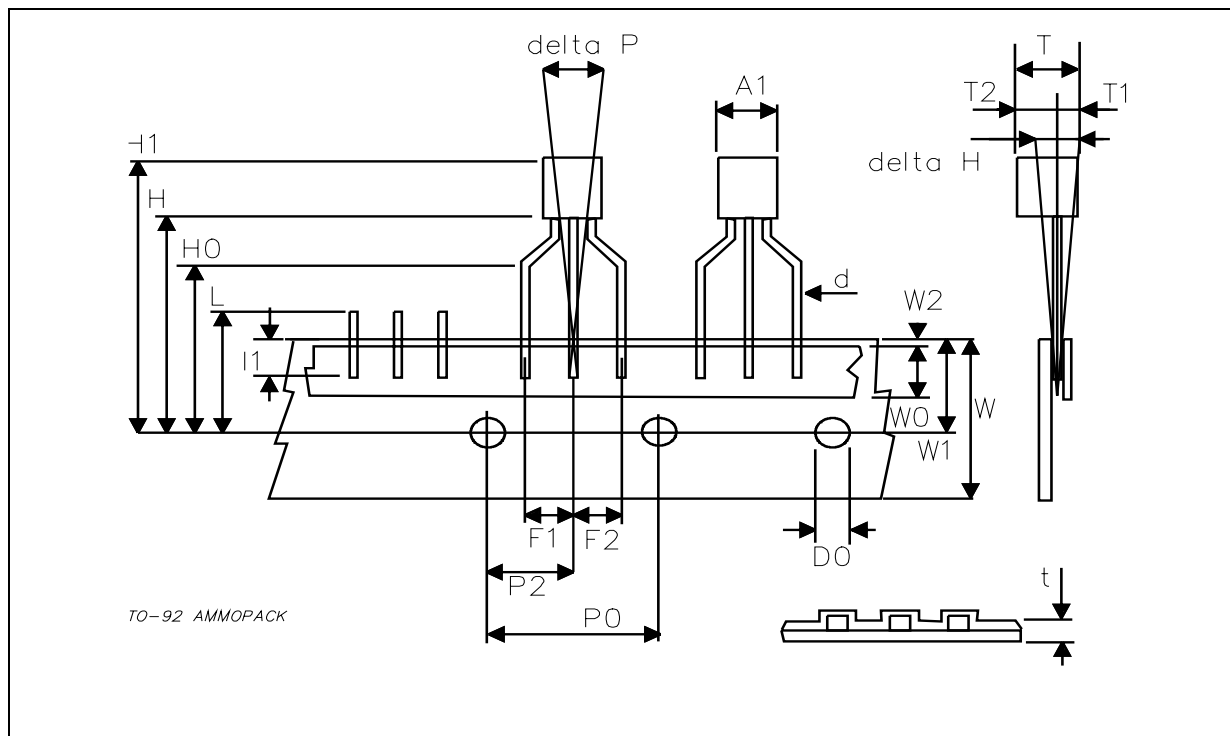

STBV32

Figure 1: Revision History

Version	Release Date	Change Designator
01-Dec-2002	1	First Release.
27-Apr-2005	1	Total dissipation value has been modified.

Information furnished is believed to be accurate and reliable. However, STMicroelectronics assumes no responsibility for the consequences of use of such information nor for any infringement of patents or other rights of third parties which may result from its use. No license is granted by implication or otherwise under any patent or patent rights of STMicroelectronics. Specifications mentioned in this publication are subject to change without notice. This publication supersedes and replaces all information previously supplied. STMicroelectronics products are not authorized for use as critical components in life support devices or systems without express written approval of STMicroelectronics.

The ST logo is a registered trademark of STMicroelectronics
All other names are the property of their respective owners

© 2005 STMicroelectronics - All Rights Reserved

STMicroelectronics group of companies

Australia - Belgium - Brazil - Canada - China - Czech Republic - Finland - France - Germany - Hong Kong - India - Israel - Italy - Japan -
Malaysia - Malta - Morocco - Singapore - Spain - Sweden - Switzerland - United Kingdom - United States of America
www.st.com