

0.635mm Pitch S.O. DIMM Socket

SX1 Series

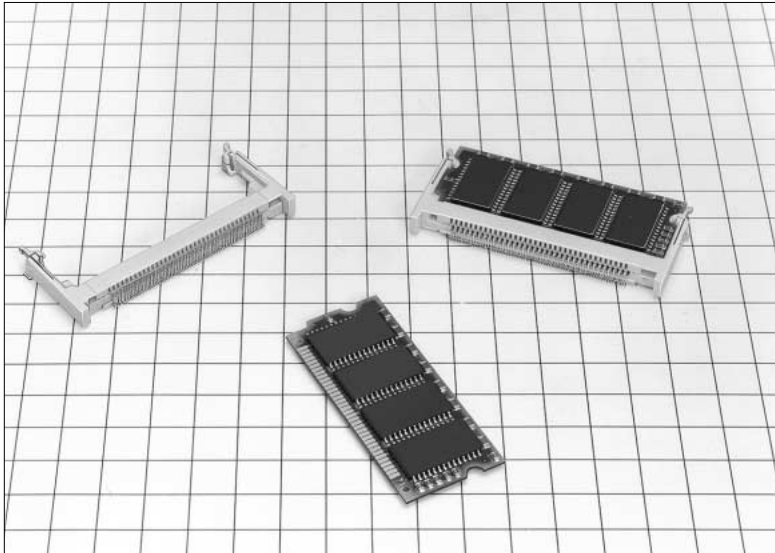

■ Features

1. 72pos. Small Outline DIMM Socket

SX1 series is a 0.635mm pitch horizontal SMT type socket applicable to

Small Outline DIMM standardized in JEDEC.

The size is about half as large as the conventional 72 contacts DRAM SIMM socket.

Corresponding to double density (both surfaces), this socket realizes high functionality and density of the module board.

2. Variation in Mounting Height

Three grades of variation are available for the mounting height.

3. Easy Insertion and Extraction of Module Board

One-touch operation to insert the module board slantly and push it downward.

Widen latches right and left, and the module board will be automatically raised.

This mechanism allows easy automatic insertion and extraction.

4. Achieve High Performance

This socket achieves high performance by the wiping effect in the insertion and the unique press-fit face contact.

5. Insertion and Extraction Operation with Click Sensibility

The unique mold twin-latch allows excellent insertion and extraction operation with a sensible click.

■ Applications

Personal computers, business equipment, Measuring instrument, telecommunication equipment, FA, game, etc.

Variation in Mounting Height

- Low Profile Type (Mounting Height: 4.0mm)



- Standard Type (Mounting Height: 5.5mm)

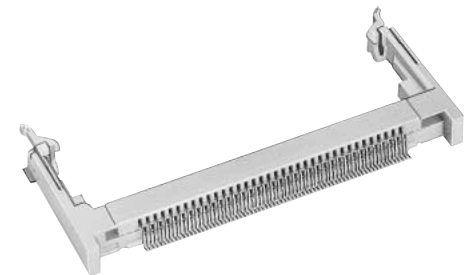

- High Profile Type (Mounting Height: 8.0mm)

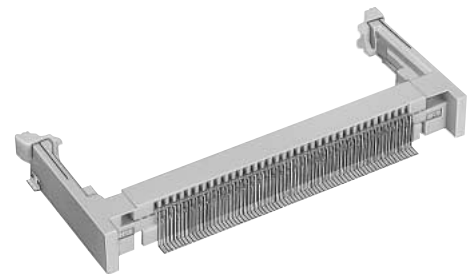

Easy Insertion and Extraction Operation of Module Board



■Product Specifications

Rating	Current rating	-55°C+85°C	Operating Humidity Range	-55°C to +85°C
	Voltage rating	125V AC		
	Operating Temperature Range	0.5A		

Item	Specification	Condition
1. Contact Resistance	35m ohms min.	100mA
2. Insulation Resistance	1000M ohms min.	250V DC
3. Withstanding voltage	No flashover or insulation breakdown.	250V AC / 1 minute
4. Vibration	No electrical discontinuity of 1μs or more	Frequency: 10 to 55 Hz, single amplitude of 0.75 mm, 50 minutes in each of the 3 directions.
5. Humidity (Steady state)	Contact resistance: 55m ohms max. Insulation Resistance: 1000M ohms min	96 hours at temperature of 40°C and humidity of 90% to 95%
6. Temperature Cycle	Contact resistance: 55m ohms max. Insulation Resistance: 1000M ohms min:	5 cycles under following condition; Temperature : -55→ +5 to 35→ +85→ +5 to 35°C Time : 30→ 10 to 15→ 30→ 10 to 15
7. Durability (Insertion/withdrawal)	Contact resistance: 55m ohms max.	30 cycles
8. Salt spray	Contact resistance: 55m ohms max.	Exposed to density 5% salt water for 48 hours

■Material

Part	Material	Finish
Contact	Phosphor copper	Selective Gold plating
Insulator	PA(UL94V-0)	—
Metal Fitting	Phosphor copper	Solder plating

■Ordering Information

SX1 **C** **A** - **72** **S** - **0.635** **SH**

①
②
③
④
⑤
⑥
⑦

① Series Name : SX1	④ Number of Contacts : 72
② Mounting Height B : Standard type (Height: 5.5mm) C : High profile type (Height: 8.0mm) E : Low profile type (Height: 4.0mm)	⑤ Contact Type : Female contact
③ DIMM Key None : 3.3V type A : 5V type	⑥ Contact Pitch : 0.635mm
	⑦ Contact type SH : SMT type

Standard Type

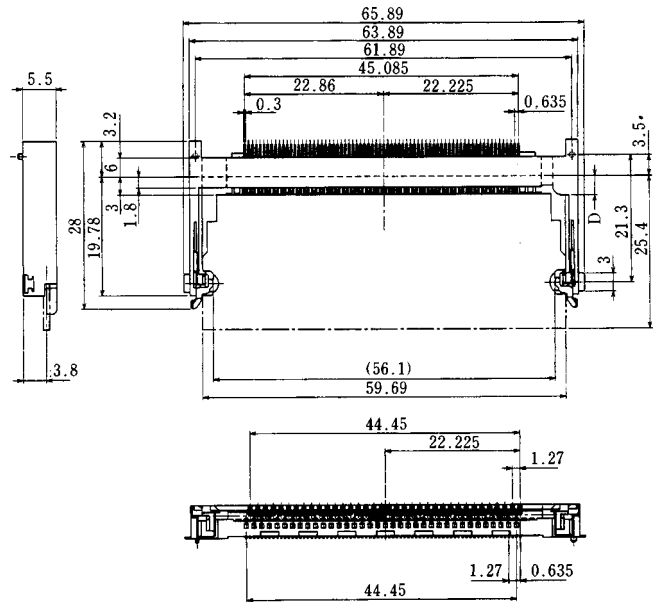
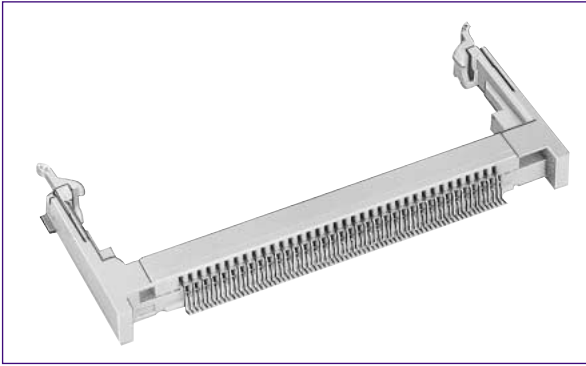

	Part Number	CL No.	Number of Contacts	Key	D	Remarks
※	SX1B-72S-0.635SH	530-0018-9	72	3.3V Type	3.1	Selective gold plating
※	SX1BA-72S-0.635SH	530-0019-1		5V Type	5.4	Selective gold plating

Note 1: The tube packaging product is provided for products marked with *. In order to designate the tube package product, add (20) to the tail of the Part Number (Delivery unit: 20 pcs per set)

Note 2: The 3.3V and 5V keys correspond to the Small Outline DIMM key.

High Profile Type

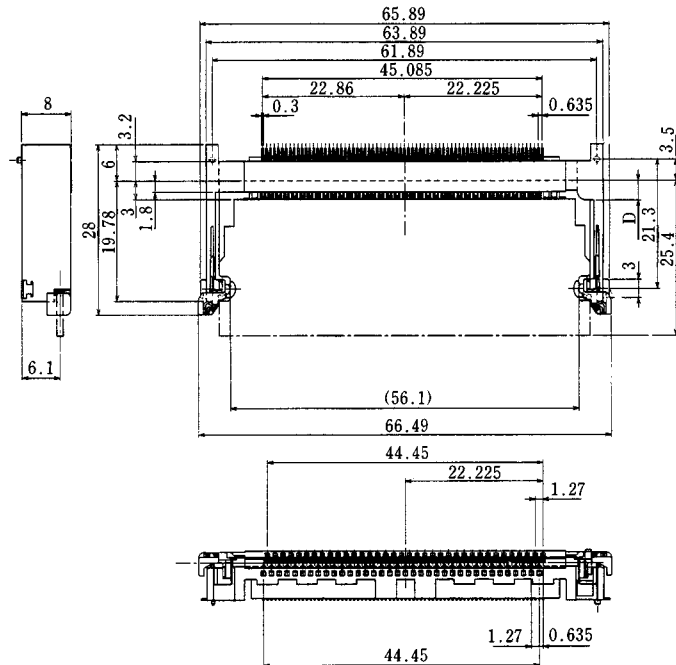
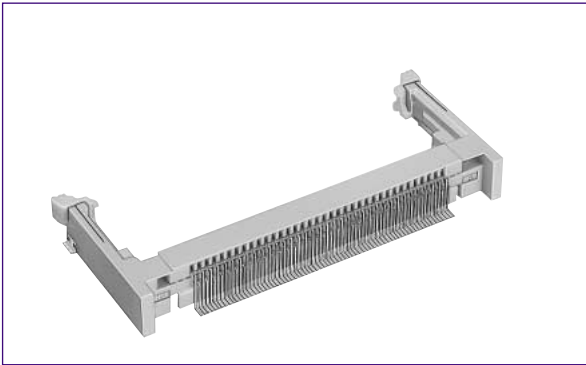

	Part Number	CL No.	Number of Contacts	Key	D	Remarks
	SX1C-72S-0.635SH	530-0003-1	72	3.3V Type	3.1	Selective gold plating
	SX1CA-72S-0.635SH	530-0004-4		5V Type	5.4	Selective gold plating

Note 2: The 3.3V and 5V keys correspond to the Small Outline DIMM key.

Low Profile Type

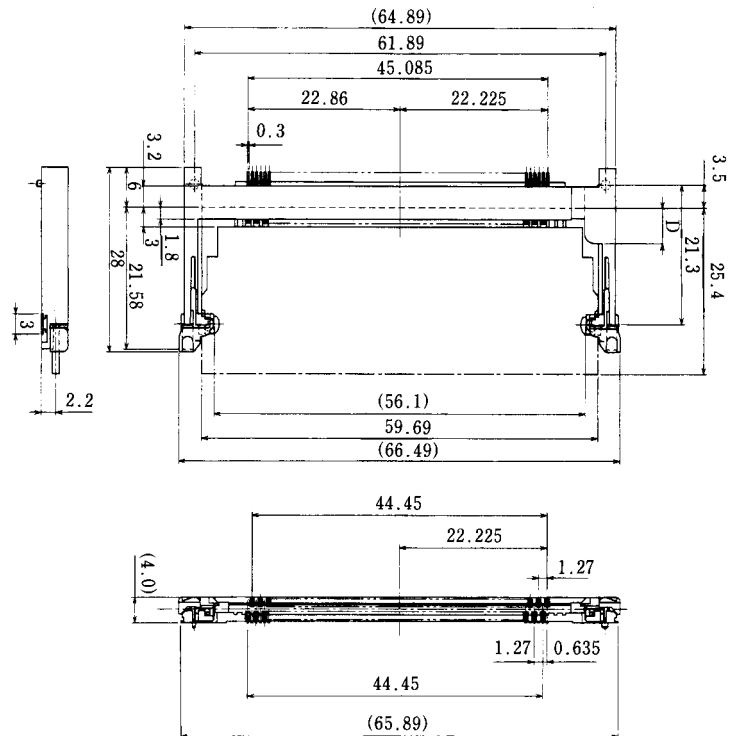
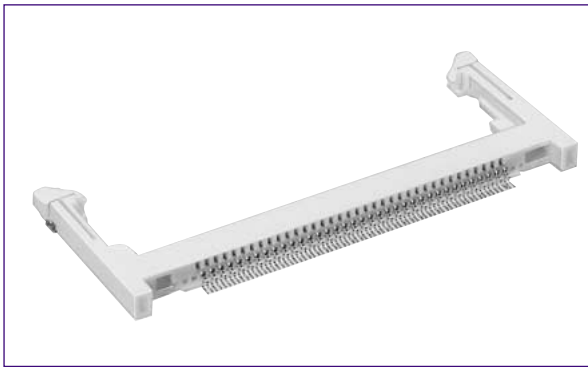

Part Number	CL No.	Number of Contacts	Key	D	Remarks
SX1E-72S-0.635SH	530-0006-0	72	3.3V Type	3.1	Selective gold plating
SX1EA-72S-0.635SH	530-0007-2		5V Type	5.4	Selective gold plating

Note 2: The 3.3V and 5V keys correspond to the Small Outline DIMM key.

Recommended Temperature Profile

IR Reflow: Recommended Temperature Profile (Up to second reflow)

Manual Soldering

Soldering iron temperature: $300 \pm 10^\circ\text{C}$

Manual soldering time: 3 seconds max.

This temperature profile is recommended.

The temperature may be slightly changed according to solder paste types and amount.

Applicable Conditions

Reflow system : IR reflow

Solder : Paste type 63 Sn/37 Pb
(Flux content 11 wt%)

Test board Glass epoxy 110mm x 85mm x 1.6 mm

Metal mask thickness: 0.15 mm

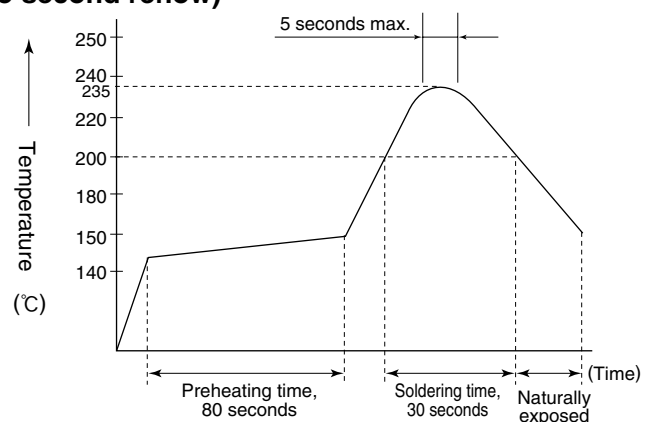

Recommended temperature profile.

The temperature may be slightly changed according to the solder paste type and amount.

◆ Precautions for use

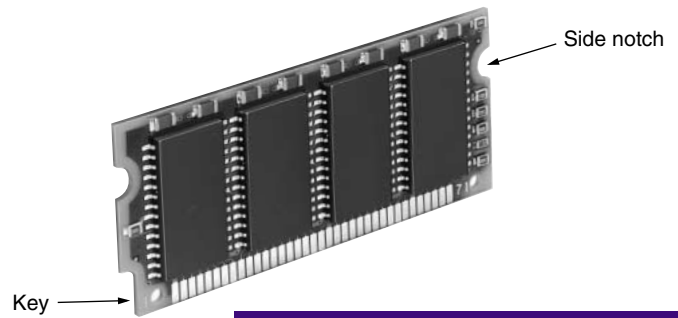
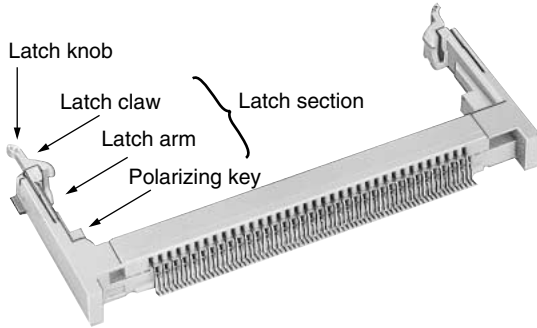

Procedures for Board Insertion

1. Adjust the socket polarizing key and the board key to the same direction.
2. Insert the board obliquely. Moreover, lay the board in parallel to the opening at angle of 20° to 30° , and softly insert the board so as to hit the socket bottom. Stopping insertion halfway will result in improper insertion.
3. Applying the board side notch in parallel to the socket bottom so that the board position cannot be displaced, press the board side notch up, and fix it to the latch portion at both socket edges. Press the board side notch, and release the notch with a snap "click" tone, if the printed board exceeds the latch claw head.

With this action, the board has been completely installed in the socket. At this time, pressing force is equivalent to the extent to turn on the electric product switch. If the stronger pressing force is needed, check whether the direction and depth to insert the board is adequate or not, and then re-push the board.

Procedures for Board Extraction

Standard type and high profile type

Apply the thumb nail to the latch knob at both socket edges. Forcibly widen the latch knobs to right and left ways, and release the latch. Then, draw the board out along an angle where the board is raised.

Low profile type

Press the top of the latch unit down with fingers to release the latch, and directly draw the board out.

Cautions

1. The latch has strength enough to endure. However, if force is applied according to other operation methods instead of the Procedures for Handling Sockets, or if further force is given in the state where the module board is raised, products could be damaged. Be sure to observe the Procedures for Handling Sockets.
2. The board is designed in compliance with JEDEC "Small Outline DIMM (Dual Inline Memory Module)". However, if the board is used instead of the recommended module board, or if the mounting product is used for other devices than DRAM memory IC, troubles due to vibration or other failures could occur. If needed, consult the HRS company.
3. The above illustration shows SX1B.
4. The recommended module board pad or sharp angle edges could cause failure in contacts. Therefore, it is recommended to offset the tie-bar from the center line, set the internal pad (0.1mm), or remove sharp corners or burrs according to the recommended sizes.
5. Don't provide the external contact surface of the module board with the convex/concave and chamfer areas at both edges. Comply with the recommended sizes.
6. When the board is mounted or housing is installed, if warpage or flexure has occurred, an excessive load could cause changes in the solder bonding area and the strength. Check individual conditions.

Procedures for Board Insertion

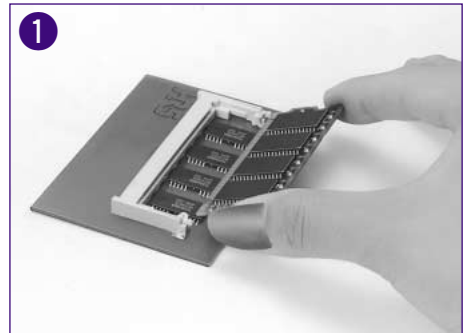

Procedures for Board Extraction

