



**ULTRA-PRECISION CML  
AnyGate® WITH INTERNAL INPUT  
AND OUTPUT TERMINATION**

**Precision Edge®  
SY58051U**

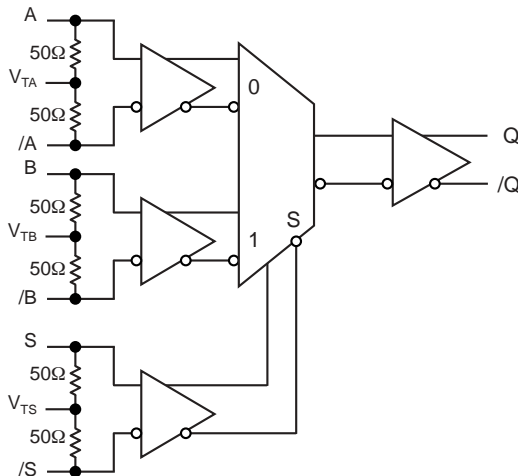
**FEATURES**

- Three matched-delay input pair provide any logic function: AND, NAND, OR, NOR, XOR
- Guaranteed AC performance over temperature and voltage:
  - DC-to > 10.7Gbps data rate throughput
  - DC-to > 7GHz clock  $f_{MAX}$
  - < 190ps Any In-to-Out  $t_{pd}$
  - $t_r / t_f < 60ps$
- Ultra low-jitter design:
  - < 1ps<sub>RMS</sub> random jitter
  - < 10ps<sub>PP</sub> deterministic jitter
  - < 10ps<sub>PP</sub> total jitter (clock)
- Unique input termination and  $V_T$  pin accepts DC-coupled and AC-coupled inputs (CML, PECL)
- Internal 50Ω output source termination
- Typical 400mV CML output swing ( $R_{IN} = 50\Omega$ )
- Internal 50Ω input termination
- Power supply 2.5V ±5% or 3.3V ±10%
- -40°C to 85°C temperature range
- Available in a 16-pin (3mm × 3mm) MLF® package

**APPLICATIONS**

- Data communication systems
- OC-192, OC-192+FEC
- All SONET OC-3 — OC-768 applications
- All Fibre Channel applications
- All GigE applications

**FUNCTIONAL BLOCK DIAGRAM**



Precision Edge®

**DESCRIPTION**

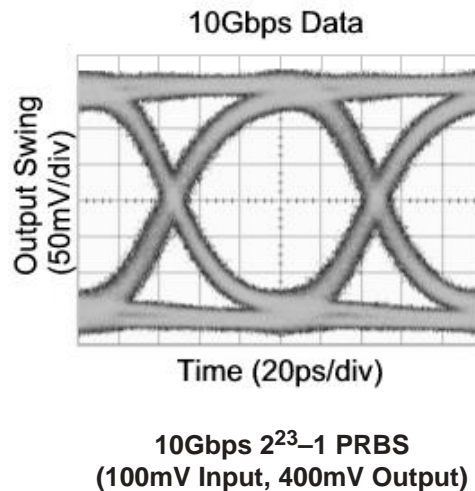
The SY58051U is an ultra-fast, low jitter universal logic gate with a guaranteed maximum data or clock throughput of 10.7Gbps or 7GHz, respectively. This AnyGate® differential logic device will produce many logic functions of two Boolean variables, such as AND, NAND, OR, NOR, DELAY, or NEGATION.

The SY58051U differential inputs include a unique, internal termination design that allows access to the termination network through a  $V_T$  pin. This feature allows the device to easily interface to different logic standards, both AC- and DC-coupled without external resistor-bias and termination networks. The result is a clean, stub-free, low-jitter interface solution. The differential CML output is optimized for 50Ω environments with internal 50Ω source termination and a 400mV output swing.

The SY58051U operates from a 2.5V or 3.3V supply, and is guaranteed over the full industrial temperature range (-40°C to +85°C). The SY58051U is part of a Micrel's Precision Edge® product family.

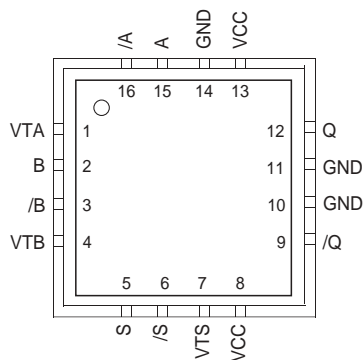
All support documentation can be found on Micrel's web site at [www.micrel.com](http://www.micrel.com).

**TYPICAL APPLICATION**



AnyGate and Precision Edge are registered trademarks of Micrel, Inc.  
MicroLeadFrame and MLF are registered trademarks of Amkor Technology, Inc.

**PACKAGE/ORDERING INFORMATION**



**16-Pin MLF® (MLF-16)**

**Ordering Information<sup>(1)</sup>**

Part Number	Package Type	Operating Range	Package Marking	Lead Finish
SY58051UMI	MLF-16	Industrial	051U	Sn-Pb
SY58051UMITR <sup>(2)</sup>	MLF-16	Industrial	051U	Sn-Pb
SY58051UMG <sup>(3)</sup>	MLF-16	Industrial	051U with Pb-Free bar-line indicator	Pb-Free NiPdAu
SY58051UMGTR <sup>(2, 3)</sup>	MLF-16	Industrial	051U with Pb-Free bar-line indicator	Pb-Free NiPdAu

**Notes:**

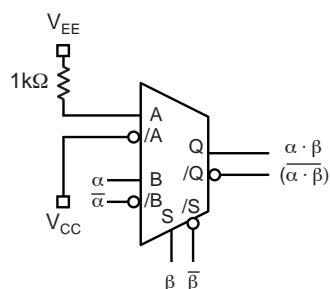
1. Contact factory for die availability. Dice are guaranteed at  $T_A = 25^\circ\text{C}$ , DC electricals only.
2. Tape and Reel.
3. Pb-Free package recommended for new designs.

**PIN DESCRIPTION**

Pin Number	Pin Name	Pin Function
1	VTA	Input Termination Center Tap: Each of the two inputs, (A, /A) terminates to this pin through a 50Ω resistor. The $V_{TA}$ pin provides a center-tap to a termination network for maximum interface flexibility. See “Input Interface Applications” section for more details.
15,16 2, 3	A, /A B, /B	Differential Input: These input pairs are the two data inputs to the device. Each pin of a pair internally terminates to the $V_{TA}$ or $V_{TB}$ pin to 50Ω. Note that these inputs will default to an indeterminate state if left open. See “Input Interface Applications” section for more details.
4	VTB	Input Termination Center Tap: Each of the two inputs, (B, /B) terminates to this pin through a 50Ω resistor. The $V_{TB}$ pin provides a center-tap to a termination network for maximum interface flexibility.
5, 6	S, /S	Differential Input: This input pair is the select input to the device. Each pin of this pair internally terminates to the $V_{TS}$ pin to 50Ω. Note that this input will default to an indeterminate state if left open. See “Input Interface Applications” section for more details.
7	VTS	Input Termination Center Tap: Each of the two inputs, S, /S terminates to this pin. The $V_{TS}$ pin provides a center-tap to a termination network for maximum interface flexibility.
8, 13	VCC	Positive Power Supply. Bypass with 0.1μF    0.01μF low ESR capacitors.
12, 9	Q, /Q	Differential Output: This CML output pair is the output of the device. It is a logic function of the A, B, and S inputs. See “Truth Tables” for details.
10, 11, 14	GND, (Exposed Pad)	Ground. Exposed pad must be connected to the same potential as GND pin.

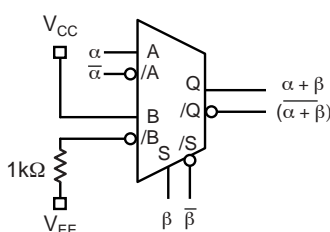
**TRUTH TABLES**

A	/A	B	/B	S	/S	Q	/Q
0	1	X	X	0	1	0	1
1	0	X	X	0	1	1	0
X	X	0	1	1	0	0	1
X	X	1	0	1	0	1	0



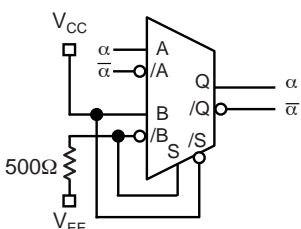
**AND/NAND**

A	$\alpha$ B	$\beta$ S	$\alpha \cdot \beta$ Q	$(\alpha \cdot \beta)$ /Q
L	L	L	L	H
L	H	L	L	H
L	L	H	L	H
L	H	H	H	L



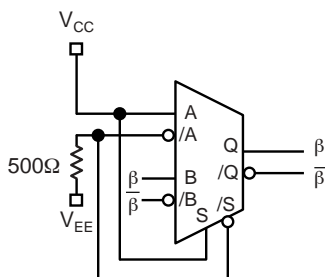
**OR/NOR**

$\alpha$ A	B	$\beta$ S	$\alpha + \beta$ Q	$(\alpha + \beta)$ /Q
L	H	L	L	H
H	H	L	H	L
L	H	H	H	L
H	H	H	H	L



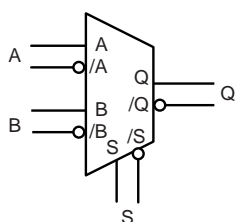
**DELAY/NEGATION**

$\alpha$ A	B	S	$\alpha$ Q	$\bar{\alpha}$ /Q
L	X	S	L	H
H	X	S	H	L



**DELAY/NEGATION**

A	$\beta$ B	S	$\beta$ Q	$\bar{\beta}$ /Q
X	L	H	L	H
X	H	H	H	L



**2:1 MUX**

S	Q	/Q
L	A	$\bar{A}$
H	B	$\bar{B}$

### Absolute Maximum Ratings<sup>(1)</sup>

Supply Voltage ( $V_{CC}$ ) ..... -0.5V to +4.0V  
 Input Voltage ( $V_{IN}$ ) ..... -0.5V to  $V_{CC}$   
 CML Output Voltage ( $V_{OUT}$ ) .....  $V_{CC} - 1.0V$  to  $V_{CC} + 0.5V$   
 Termination Current<sup>(3)</sup>  
     Source or Sink Current on  $V_{TA}$ ,  $V_{TB}$ ,  $V_{TS}$  .....  $\pm 60mA$   
 Input Current  
     Source or Sink Current on A, /A, B, /B, S, /S .....  $\pm 30mA$   
 Lead Temperature (soldering, 20 sec.) ..... +260°C  
 Storage Temperature ( $T_S$ ) ..... -65°C to +150°C

### Operating Ratings<sup>(2)</sup>

Supply Voltage ( $V_{CC}$ ) ..... +2.375V to +2.625V or  
     ..... +3.0V to +3.6V  
 Ambient Temperature ( $T_A$ ) ..... -40°C to +85°C  
 Package Thermal Resistance<sup>(4)</sup>  
     MLF® ( $\theta_{JA}$ ) .....  
     Still-Air ..... 61°C/W  
     MLF® ( $\psi_{JB}$ ) .....  
     Junction-to-Board ..... 38°C/W

## DC ELECTRICAL CHARACTERISTICS<sup>(5)</sup>

$T_A = -40^\circ C$  to  $+85^\circ C$ , unless otherwise noted.

Symbol	Parameter	Condition	Min	Typ	Max	Units
$V_{CC}$	Power Supply	$V_{CC} = 2.5V$ .	2.375	2.5	2.625	V
		$V_{CC} = 3.3V$ .	3.0	3.3	3.6	V
$I_{CC}$	Power Supply Current	No Load, max. $V_{CC}$ .		55	70	mA
$R_{DIFF\_IN}$	Differential Input Resistance (A-to-/A or B-to-/B or S-to-/S)		80	100	120	$\Omega$
$R_{IN}$	Input Resistance (A-to- $V_{TA}$ , B-to- $V_{TB}$ or S-to- $V_{TS}$ )		40	50	60	$\Omega$
$V_{IH}$	Input HIGH Voltage (A, /A or B, /B or S, /S)	<b>Note 6</b>	1.2		$V_{CC}$	V
$V_{IL}$	Input LOW Voltage (A, /A or B, /B or S, /S)	<b>Note 6</b>	0		$V_{IH} - 0.1$	V
$V_{IN}$	Input Voltage Swing (A, /A or B, /B or S, /S)	<b>Note 6</b> See Figure 2a.	100			mV
$V_{DIFF\_IN}$	Differential Input Voltage Swing $ A-, /A $ or $ B-, /B $ or $ S-, /S $	<b>Note 6</b> See Figure 2b.	200			mV
$ I_{IN} $	Input Current (A, /A or B, /B or S, /S)	<b>Note 6</b>			21	mA

**Notes:**

1. Permanent device damage may occur if the ratings in the "Absolute Maximum Ratings" section are exceeded. This is a stress rating only and functional operation is not implied for conditions other than those detailed in the operational sections of this data sheet. Exposure to absolute maximum ratings conditions for extended periods may affect device reliability.
2. The data sheet limits are not guaranteed if the device is operated beyond the operating ratings.
3. Due to the limited drive capability use for input of the same package only.
4. Package thermal resistance assumes exposed pad is soldered (or equivalent) to the devices most negative potential on the PCB.  $\psi_{JB}$  uses 4-layer  $\theta_{JA}$  in still-air, unless otherwise stated.
5. The circuit is designed to meet the DC specifications shown in the above table after thermal equilibrium has been established.
6. Due to the internal termination (see Figure 1a) the input current depends on the applied voltages at A, /A and  $V_{TA}$  inputs, the B, /B and  $V_{TB}$  inputs or the S, /S and  $V_{TS}$  inputs. Do not apply a combination of voltages that causes the input current to exceed the maximum limit!

**CML OUTPUTS DC ELECTRICAL CHARACTERISTICS<sup>(7)</sup>**

V<sub>CC</sub> = 2.5V ±5% or 3.3V ±10%; R<sub>L</sub> = 100Ω across output pair or equivalent; T<sub>A</sub> = -40°C to +85°C; unless otherwise noted.

Symbol	Parameter	Condition	Min	Typ	Max	Units
V <sub>OH</sub>	Output HIGH Voltage Q, /Q		V <sub>CC</sub> -0.020		V <sub>CC</sub>	V
V <sub>OUT</sub>	Output Voltage Swing Q, /Q	See Figure 2a.	325	400	500	mV
V <sub>DIFF_OUT</sub>	Differential Output Voltage Swing Q, /Q	See Figure 2b.	650	800	1000	mV
R <sub>OUT</sub>	Output Source Impedance Q, /Q		40	50	60	Ω

**AC ELECTRICAL CHARACTERISTICS<sup>(8)</sup>**

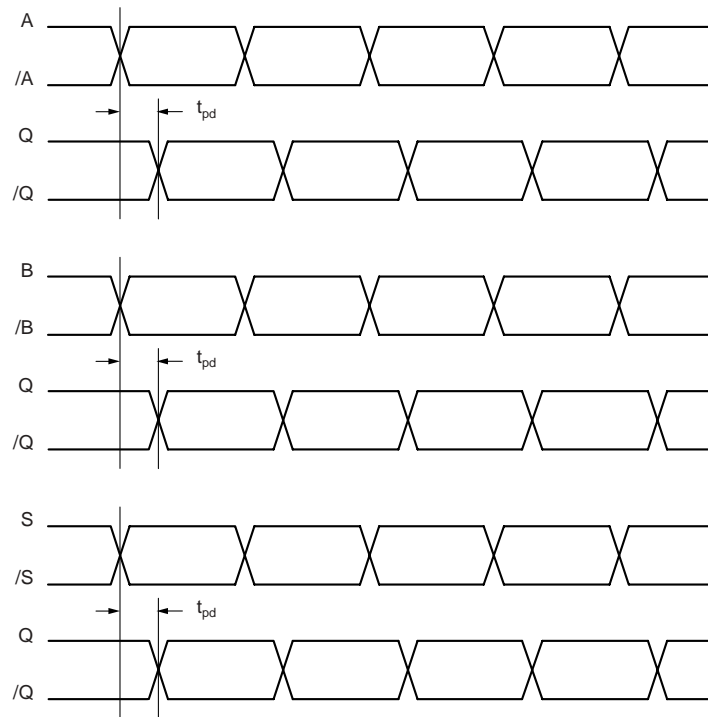
V<sub>CC</sub> = 2.5V ±5% or 3.3V ±10%; R<sub>L</sub> = 100Ω across output pair or equivalent; T<sub>A</sub> = -40°C to +85°C; unless otherwise noted.

Symbol	Parameter	Condition	Min	Typ	Max	Units
f <sub>MAX</sub>	Maximum Operating Frequency	Clock NRZ Data	10.7	7		GHz Gbps
t <sub>pd</sub>	Propagation Delay Any Input (A, B, S)-to-Q		70		190	ps
t <sub>SKEW</sub>	Part-to-Part Skew	<b>Note 9</b>			100	ps
t <sub>JITTER</sub>	Data Random Jitter (RJ)	<b>Note 10</b>			1	ps <sub>RMS</sub>
	Deterministic Jitter (DJ)	<b>Note 11</b>			10	ps <sub>PP</sub>
	Clock Cycle-to-Cycle Jitter (RJ)	<b>Note 12</b>			1	ps <sub>RMS</sub>
	Total Jitter (TJ)	<b>Note 13</b>			10	ps <sub>PP</sub>
t <sub>r</sub> , t <sub>f</sub>	Output Rise/Fall Times (20% to 80%)	At full output swing.	20		60	ps

**Notes:**

- The circuit is designed to meet the DC specifications shown in the above table after thermal equilibrium has been established.
- Measured with 100mV input swing. See "Timing Diagrams" section for definition of parameters. High-frequency AC parameters are guaranteed by design and characterization.
- Skew is defined for two parts with identical power supply voltages at the same temperature and with no skew of the edges at the respective inputs.
- Random jitter is measured with a K28.7 comma detect character pattern, measured at 2.5Gbps/3.2Gbps.
- Deterministic jitter is measured at 2.5Gbps/3.2Gbps with both K28.5 and 2<sup>23</sup>-1 PRBS pattern.
- Cycle-to-cycle jitter definition: the variation of periods between adjacent cycles, T<sub>n</sub>-T<sub>n-1</sub> where T is the time between rising edges of the output signal.
- Total jitter definition: with an ideal clock input of frequency ≤ f<sub>MAX</sub>, no more than one output edge in 10<sup>12</sup> output edges will deviate by more than the specified peak-to-peak jitter value.

**TIMING DIAGRAM**



**INPUT AND OUTPUT STAGE INTERNAL TERMINATION**

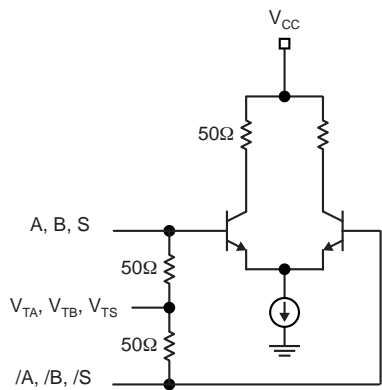


Figure 1a. Simplified Differential Input Stage

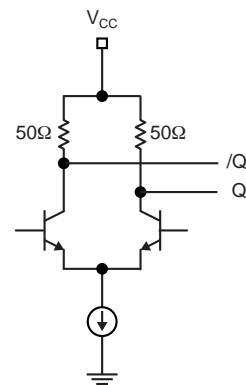


Figure 1b. Simplified Differential Output Stage

**DEFINITION OF SINGLE-ENDED AND DIFFERENTIAL SWINGS**

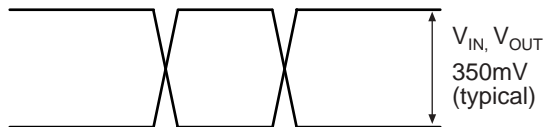


Figure 2a. Single-Ended Swing

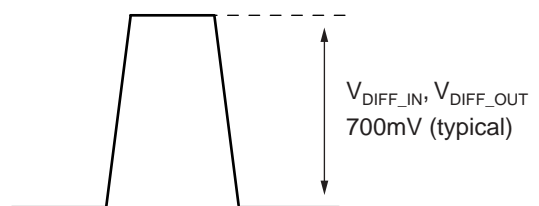
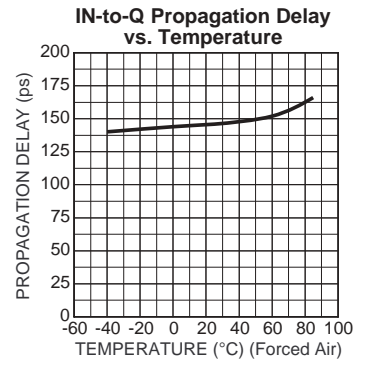
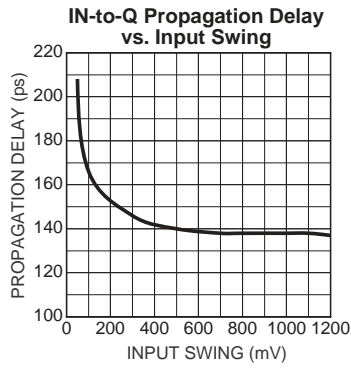
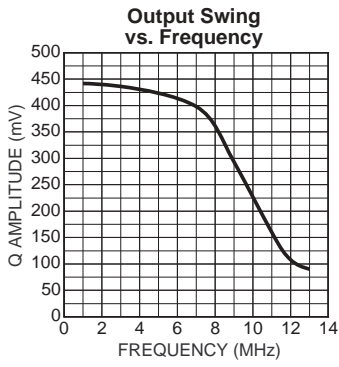


Figure 2b. Differential Swing

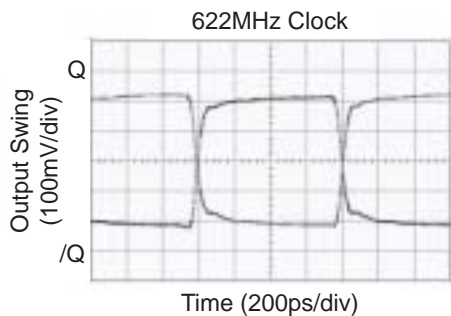
**TYPICAL OPERATING CHARACTERISTICS**

$V_{CC} = 3.3V$ ,  $GND = 0$ ,  $V_{IN} = 800mV$ .

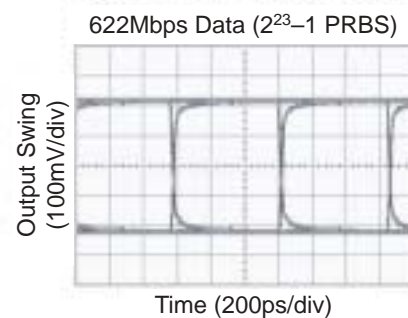


**FUNCTIONAL CHARACTERISTICS**

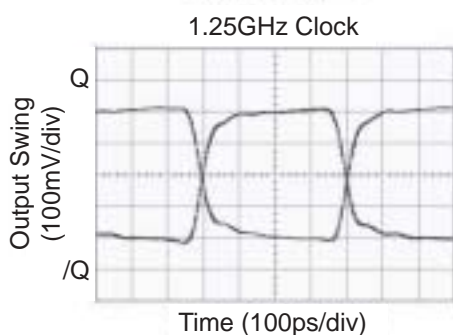
V<sub>CC</sub> = 3.3V, GND = 0, V<sub>IN</sub> = 800mV.



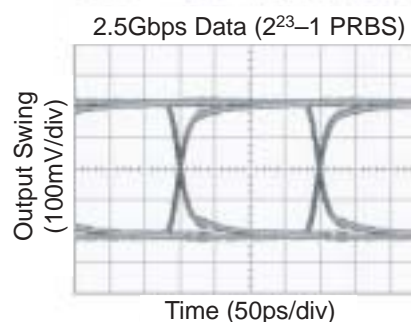
**10 K28.7 Clock Pattern**



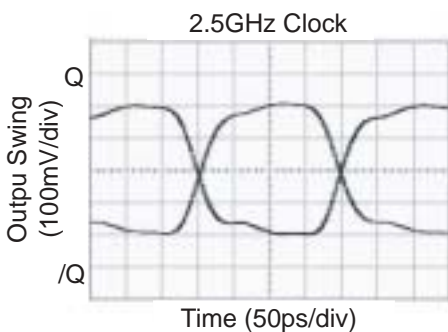
**$2^{23}-1$  PRBS Pattern**



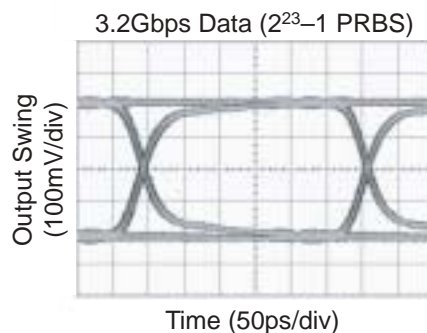
**10 K28.7 Clock Pattern**



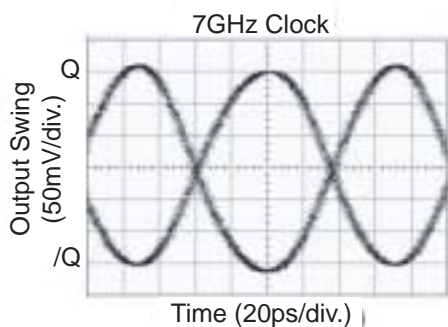
**$2^{23}-1$  PRBS Pattern**



**10 K28.7 Clock Pattern**



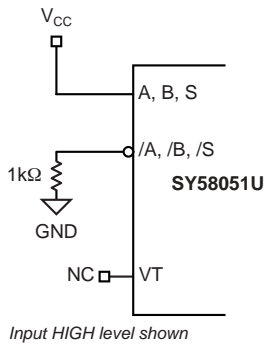
**$2^{23}-1$  PRBS Pattern**



**10 K28.7 Clock Pattern**

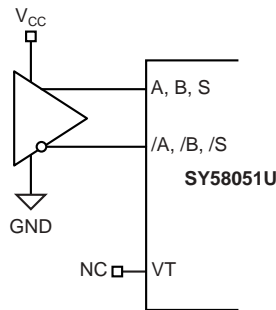


**INPUT INTERFACE APPLICATIONS**

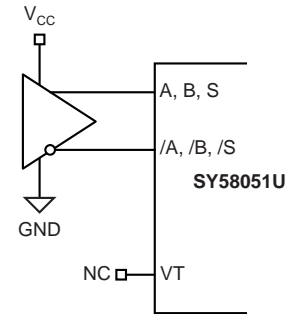


Input HIGH level shown

**Figure 3a. Static Input Level**

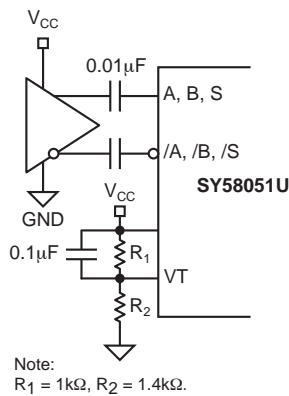


**Figure 3b. LVDS Interface (DC-Coupled)**



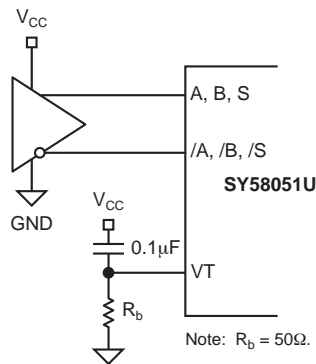
**Figure 3c. CML Interface (DC-Coupled)**

Option:  $V_T$  may be connected to  $V_{CC}$ .



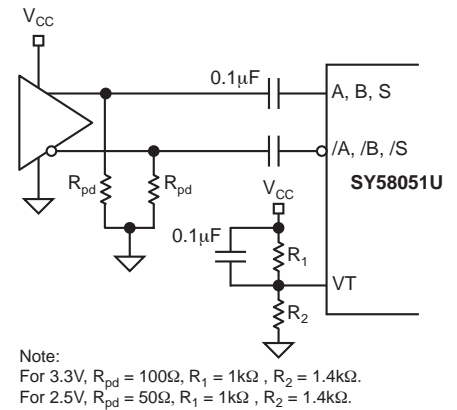
Note:  
 $R_1 = 1k\Omega$ ,  $R_2 = 1.4k\Omega$ .

**Figure 3d. CML Interface (AC-Coupled)**



Note:  $R_b = 50\Omega$ .

**Figure 3e. PECL Interface (DC-Coupled)**



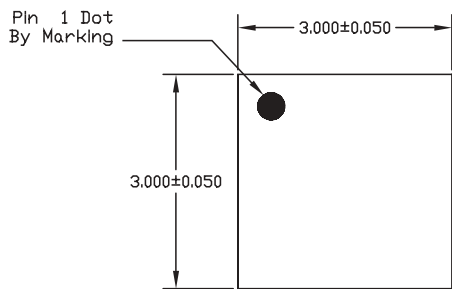
Note:  
For 3.3V,  $R_{pd} = 100\Omega$ ,  $R_1 = 1k\Omega$ ,  $R_2 = 1.4k\Omega$ .  
For 2.5V,  $R_{pd} = 50\Omega$ ,  $R_1 = 1k\Omega$ ,  $R_2 = 1.4k\Omega$ .

**Figure 3f. PECL Interface (AC-Coupled)**

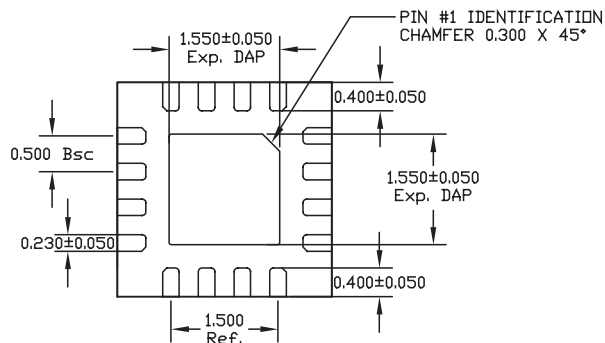
**RELATED PRODUCT AND SUPPORT DOCUMENTATION**

Part Number	Function	Data Sheet Link
SY58016L	3.3V 10Gbps Differential CML Line Driver/ Receiver with Internal Termination	<a href="http://www.micrel.com/product-info/products/sy58016l.shtml">www.micrel.com/product-info/products/sy58016l.shtml</a>
SY58052U	10Gbps Clock/Data Retimer with 50Ω Input Termination	<a href="http://www.micrel.com/product-info/products/sy58052u.shtml">www.micrel.com/product-info/products/sy58052u.shtml</a>
	MLF® Application Note	<a href="http://www.amkor.com/products/notes_papers/MLF_AppNote_0902.pdf">www.amkor.com/products/notes_papers/MLF_AppNote_0902.pdf</a>
HBW Solutions	New Products and Applications	<a href="http://www.micrel.com/product-info/products/solutions.shtml">www.micrel.com/product-info/products/solutions.shtml</a>

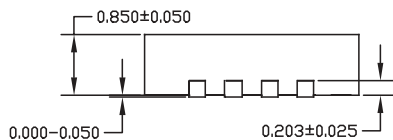
**16-PIN MicroLeadFrame® (MLF-16)**



TOP VIEW

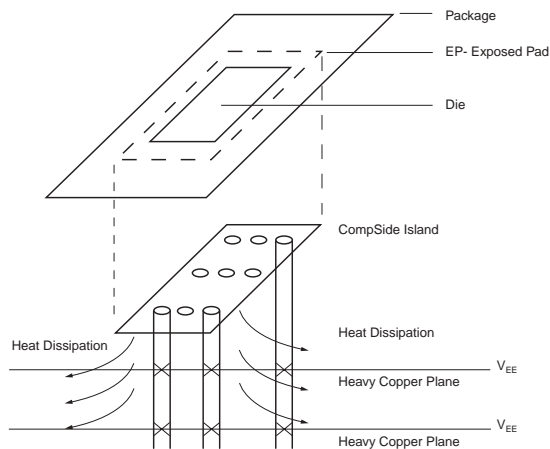


BOTTOM VIEW



SIDE VIEW

- NOTE:
1. ALL DIMENSIONS ARE IN MILLIMETERS.
  2. MAX. PACKAGE WARPAGE IS 0.05 mm.
  3. MAXIMUM ALLOWABLE BURRS IS 0.076 mm IN ALL DIRECTIONS.
  4. PIN #1 ID ON TOP WILL BE LASER/INK MARKED.



**PCB Thermal Consideration for 16-Pin MLF® Package**  
(Always solder, or equivalent, the exposed pad to the PCB)

**Package Notes:**

1. Package meets Level 2 qualification.
2. All parts dry-packaged before shipment.
3. Exposed pads must be soldered to a ground for proper thermal management.

**MICREL, INC. 2180 FORTUNE DRIVE SAN JOSE, CA 95131 USA**

TEL + 1 (408) 944-0800 FAX + 1 (408) 474-1000 WEB <http://www.micrel.com>

The information furnished by Micrel in this data sheet is believed to be accurate and reliable. However, no responsibility is assumed by Micrel for its use. Micrel reserves the right to change circuitry and specifications at any time without notification to the customer.

Micrel Products are not designed or authorized for use as components in life support appliances, devices or systems where malfunction of a product can reasonably be expected to result in personal injury. Life support devices or systems are devices or systems that (a) are intended for surgical implant into the body or (b) support or sustain life, and whose failure to perform can be reasonably expected to result in a significant injury to the user. A Purchaser's use or sale of Micrel Products for use in life support appliances, devices or systems is at Purchaser's own risk and Purchaser agrees to fully indemnify Micrel for any damages resulting from such use or sale.