

FEATURES

- DC bias current adjustable to 25mA
- Buffered Loss-of-Signal output when used with SY88903
- Controlled laser diode turn on
- Laser diode over-current detect
- Monitor diode power control circuit
- Laser diode driver enable
- Designed for use with SY88902 and SY88903
- Single power supply
- Available in 16-pin MSOP

DESCRIPTION

The SY88904 is an integrated controller for the SY88902 Laser Driver and SY88903 Laser Receiver that provides power control and system interface functions for a complete module solution. The SY88904 is designed to provide the laser diode with an independent DC threshold current (IBIAS) source to assure optimum laser diode performance. It has special safety features which disable the currents to the laser diode if certain faults are detected in the module. The SY88904 also provides buffered Loss-of-Signal (LOS) output in open collector level. The device is designed for fast and accurate calibration of the laser diode as well as deriving the control signals for system integration.

The SY88904 provides for delayed turn on of the laser diode on system start up, chatter-free Loss-of-Signal, Low VCC detect and laser diode over-current situations. Once the optimal operating point is determined and set for a specific laser diode, the threshold current (IBIAS) is designed to automatically compensate for laser diode aging and module temperature.

APPLICATIONS

- Controller for High Speed Optical Data Transmission
- 1.25Gbps Gigabit Ethernet
- 531 Mbps and 1062Mbps Fibre Channel
- 622Mbps SONET
- Gigabit Interface Converter

BLOCK DIAGRAM

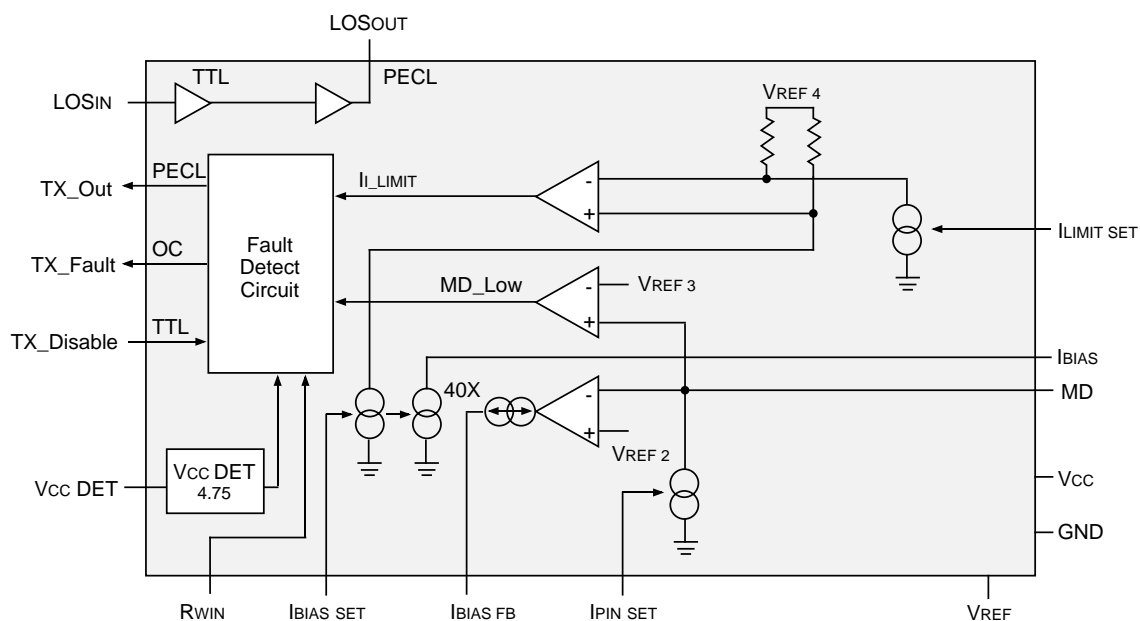

PACKAGE/ORDERING INFORMATION

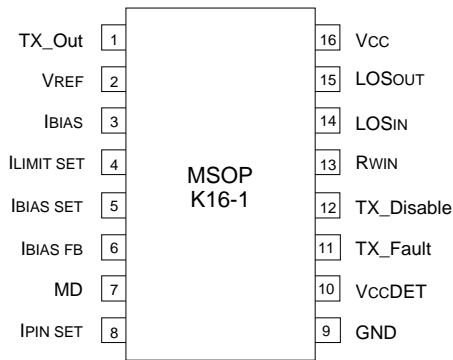

16-Pin MSOP (K16-1)

Ordering Information

Part Number	Package Type	Operating Range	Package Marking	Lead Finish
SY88904KC	K16-1	Commercial	904	Sn-Pb
SY88904KCTR ⁽¹⁾	K16-1	Commercial	904	Sn-Pb
SY88904KH	K16-1	Commercial	904 with Pb-Free bar-line indicator	Pb-Free NiPdAu
SY88904KHTR ⁽¹⁾	K16-1	Commercial	904 with Pb-Free bar-line indicator	Pb-Free NiPdAu

Note:

- 1. Tape and Reel.

PIN DEFINITIONS

Pin	Type	Description
VCC	Power Supply	Positive Power supply
GND	Ground	Ground
TX_Out	PECL Output	Transmitter Enable
TX_Fault	Open Collector Output	Module Fault
TX_Disable	TTL Input	Transmitter Disable and Fault Reset
LOSIN	TTL Input	Loss-of-Signal Input from Limiting Post Amplifier
VREF	Analog Output	Reference Voltage
IPIN SET	Analog Input	Adjustable, Resistor to VREF sets Min. Monitor Diode Photo Current
RWIN	Analog Input	Restart Window
LOSOUT	PECL Output	Loss-of-Signal PECL output
IBIASFB	Analog Output	Monitor Diode Feedback
IBIASSET	Analog Input	Adjustable, Resistor to VREF sets the DC bias current for the Laser Diode
MD	Analog Input	Monitor Diode Connection
IBIAS	Analog Input	DC bias current for the Laser Diode
ILIMIT SET	Analog Input	Adjustable, Resistor to VREF sets Laser Diode over current fail point.

ABSOLUTE MAXIMUM RATINGS⁽¹⁾

Symbol	Rating	Value	Unit
V _{CC}	Power Supply Voltage	0 to +7.0	V
TX_Disable, LOS	Input Voltage	0 to V _{CC}	V
LOSoc, IPIN SET, I _{LIMIT} SET IBIASFB, IBIAS SET	Others; I/O Voltage	-0.3V, V _{CC} +0.3V	V
TX_Out	Output Voltage (with 50Ω load)	V _{CC} -2.5V, V _{CC} +0.3V	V
T _A	Operating Temperature Range	0°C to +85°C	°C
T _{store}	Storage Temperature Range	-55°C to +125°C	°C
	Theta Junction to Ambient	93	°C/W

Note:

- Permanent device damage may occur if absolute maximum ratings are exceeded. This is a stress rating only and functional operation is not implied at conditions other than those detailed in the operational sections of this data sheet. Exposure to absolute maximum rating conditions for extended periods may affect device reliability.

DC ELECTRICAL CHARACTERISTICS

V_{CC} = +5V, R_{LOAD} = 50Ω to 3V, T_A = 0°C to +85°C

Symbol	Parameter	T _A = 0°C			T _A = +25°C			T _A = +85°C			Unit	Conditions
		Min.	Typ.	Max.	Min.	Typ.	Max.	Min.	Typ.	Max.		
I _{CC}	Power Supply Current	—	—	60	—	—	60	—	—	60	mA	No output load
IBIAS	IBIAS Output Current	2	—	25	2	—	25	2	—	25	mA	
IBIAS SET	IBIAS SET Input Current	—	—	0.625	—	—	0.625	—	—	0.625	mA	

DETAILED DESCRIPTION

The SY88904 is an integrated control circuit for laser diode modules intended for high-frequency fiber-optic applications. The device is designed to operate with the SY88902 laser diode driver providing Automatic Power Control (APC) which provides bias and modulation current control, laser diode driver enable and monitor diode interface. The device also interfaces with the SY88903 high-speed limiting amplifier providing chatter-free Loss of Signal function. The system functions provided include laser diode over-current detection, module fault signal and transmit disable control. The SY88904 also provides power up cycling of laser diode current and the fault detect signal.

Laser Diode Supply Current

The SY88904 provides the adjustable drive current for the laser diode, DC bias.

Laser Diode Over-Current Detection

The SY88904 provides the ability to set an upper limit fail point for the laser diode. ILIMIT SET sets an upper limit for the average current present at the IBIAS pin.

Monitor Diode

The MD pin on the SY88904 provides low frequency light intensity, laser power out feedback from the monitor diode in the laser diode package. This feedback is used to adjust the IBIAS level through the Automatic Power Control circuit to maintain a near constant power output from the laser diode. The SY88904 will also generate a fault if the MD pin receives photo current less than IPINSET or is no longer connected to the monitor diode.

Laser Diode Driver Enable

The SY88904 provides a TX_Out pin used to control the output of the laser diode driver, through the Enable pin, of the SY88902. This is a single ended PECL output.

Module Fault

The SY88904 provides an open collector output, TX_Fault, that indicates to the host system that the module is in a fault condition. The SY88904 will assert TX_Fault when a low VCC condition is detected, when the monitor diode is not connected or when a laser diode over-current condition is detected. The SY88904 will attempt to clear a TX_Fault condition if the device is power cycled or a reset cycle is initiated with TX_Disable. When the SY88904 is in a TX_Fault condition Ibias will be removed, TX_Out will be negated and fault detection will be disabled.

Power Up Sequence, TX_Disable asserted

The SY88904 will power up in a TX_Fault condition and will remain in a fault condition while TX_Disable is asserted.

Power Up Sequence, TX_Disable negated

The SY88904 will power up in a TX_Fault condition and will remain in a fault condition until VCC is within operational limits, at which time an initialization sequence will be started.

TX_Disable Cycle, TX_Fault Negated

When the SY88904 is not in a TX_Fault condition, a rising edge of TX_Disable will cause the SY88904 to enter a TX_Fault condition. The falling edge of TX_Disable will cause a power up sequence to be started.

TX_Disable Cycle, TX_Fault Asserted

When the SY88904 is in a TX_Fault condition, the falling edge of TX_Disable will cause an initialization sequence to be started.

TX_Disable Cycle, during an initialization cycle

A rising edge of TX_Disable will cause the SY88904 to terminate the current initialization cycle and remain in a TX_Fault condition. The falling edge of TX_Disable will cause the initialization sequence to be restarted.

Initialization Sequence

The initialization sequence consists of a delay, set by the RC time constant on the Rwin input, followed by a power up sequence.

Power Up Sequence

A power up sequence will negate TX_Fault and then ramp up Ibias, controlled by the capacitor on the Rwin input and an internal 1mA current, followed by TX_OUT being negated and fault checking. If a fault occurs at this time the module will enter a TX_Fault conditions, otherwise the module will be ready for operation.

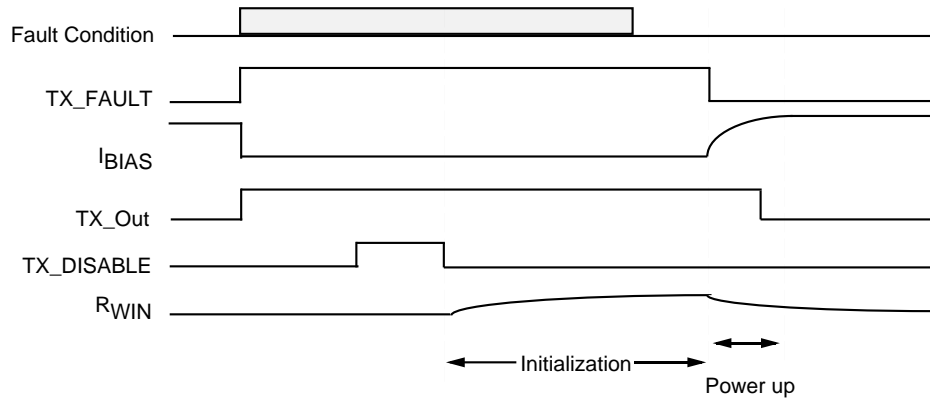

Figure 1. Reset of Temporary Fault

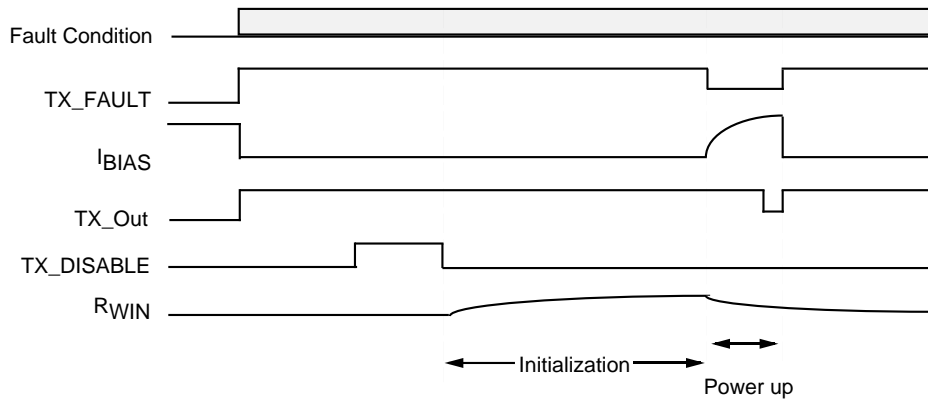

Figure 2. Reset of Fatal Fault

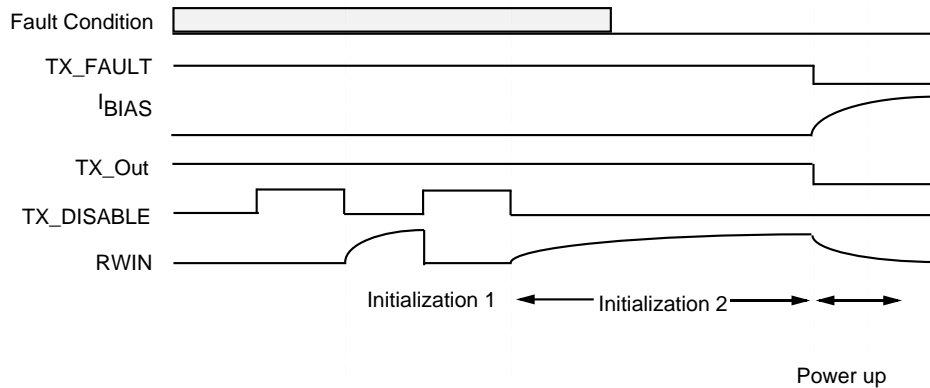

Figure 3. Reset During Initialization

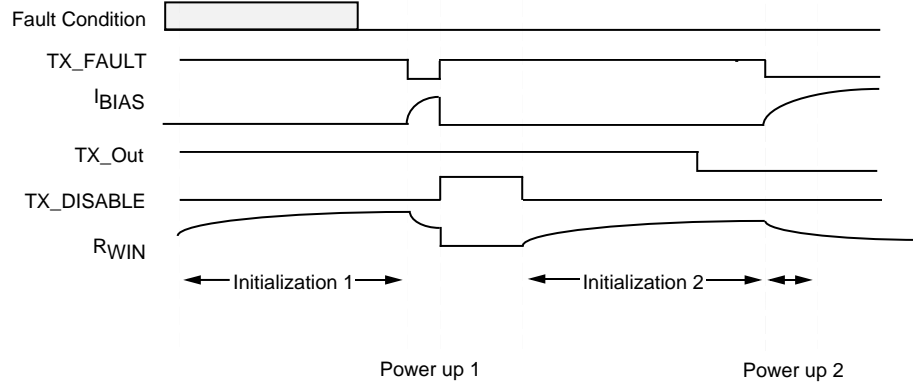

Figure 4. Reset During Power Up

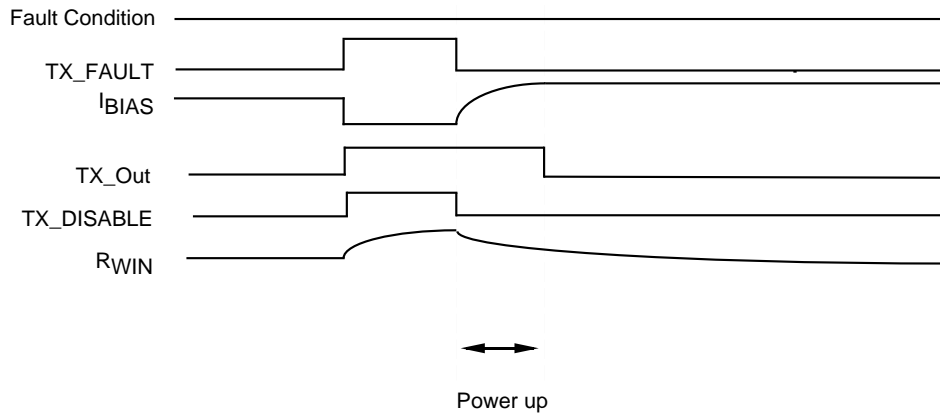
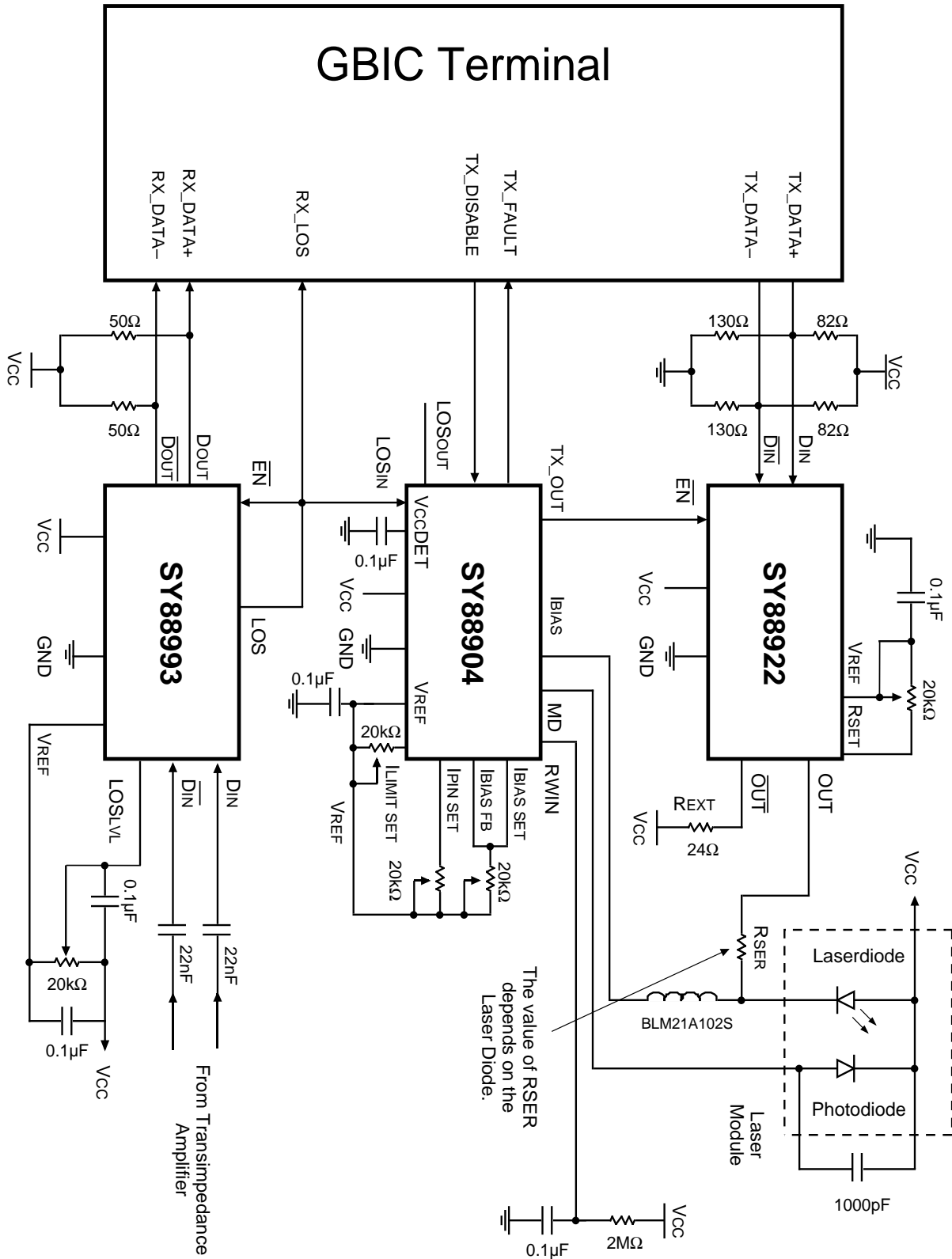
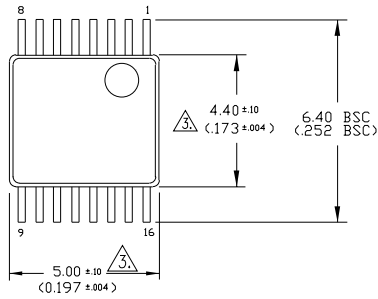

Figure 5. Reset Cycle

APPLICATION EXAMPLE FOR 3-CHIP SET SOLUTION



16 LEAD MSOP (K16-1)



TOP VIEW

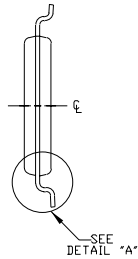

END VIEW

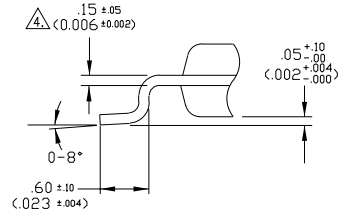

DETAIL 'A'
(VIEW ROTATED 90° C.W.)

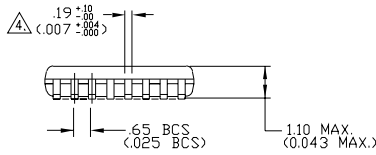

SIDE VIEW

- NOTES:
1. DIMENSIONS ARE IN MM[INCHES].
 2. CONTROLLING DIMENSION: MM.
- △ DIMENSION DOES NOT INCLUDE MOLD FLASH OF 0.254[0.010] MAX.
- △ THIS DIMENSION INCLUDES LEAD FINISH.

Rev. 01

MICREL, INC. 2180 FORTUNE DRIVE SAN JOSE, CA 95131 USA

TEL + 1 (408) 944-0800 FAX + 1 (408) 474-1000 WEB <http://www.micrel.com>

The information furnished by Micrel in this data sheet is believed to be accurate and reliable. However, no responsibility is assumed by Micrel for its use. Micrel reserves the right to change circuitry and specifications at any time without notification to the customer.

Micrel Products are not designed or authorized for use as components in life support appliances, devices or systems where malfunction of a product can reasonably be expected to result in personal injury. Life support devices or systems are devices or systems that (a) are intended for surgical implant into the body or (b) support or sustain life, and whose failure to perform can be reasonably expected to result in a significant injury to the user. A Purchaser's use or sale of Micrel Products for use in life support appliances, devices or systems is at Purchaser's own risk and Purchaser agrees to fully indemnify Micrel for any damages resulting from such use or sale.

© 2005 Micrel, Incorporated.