



The complete schematic of EL7515 demo board is shown in Figure 1. With different components stuffed, this

demo board can easily be configured into the applications shown in this technical brief. The standard demo board being sent out is the complete 5V to 12V converter shown in Figure 2, which occupies less than 0.4 in² area with components on top side only. Layout diagrams are given at the end of this document.

1. $V_{IN} = 2V-5.5V$. Can be higher with higher voltage rated C_1
2. $V_O = 12V$. Can be set according to the following formula:

$$V_O = V_{FB} \times \left(1 + \frac{R_2}{R_1} \right)$$

where V_{FB} is shown in the V_{FB} vs V_{DD} curve.

3. I_O - up to 600mA depending on input voltage, provided that diode and inductor can handle the corresponding currents (refer to data sheet for the chart)
4. Switching frequency - can be set by R_3
5. R_4 can be $10\Omega - 51\Omega$ if V_O is less than 10V. If V_O is larger than 12V, it can be calculated by:

$$R_4 = \frac{V_O - 10}{I_{DD}}$$

where I_{DD} is a function of switching frequency, as shown in the I_{DD} vs f_S curve.

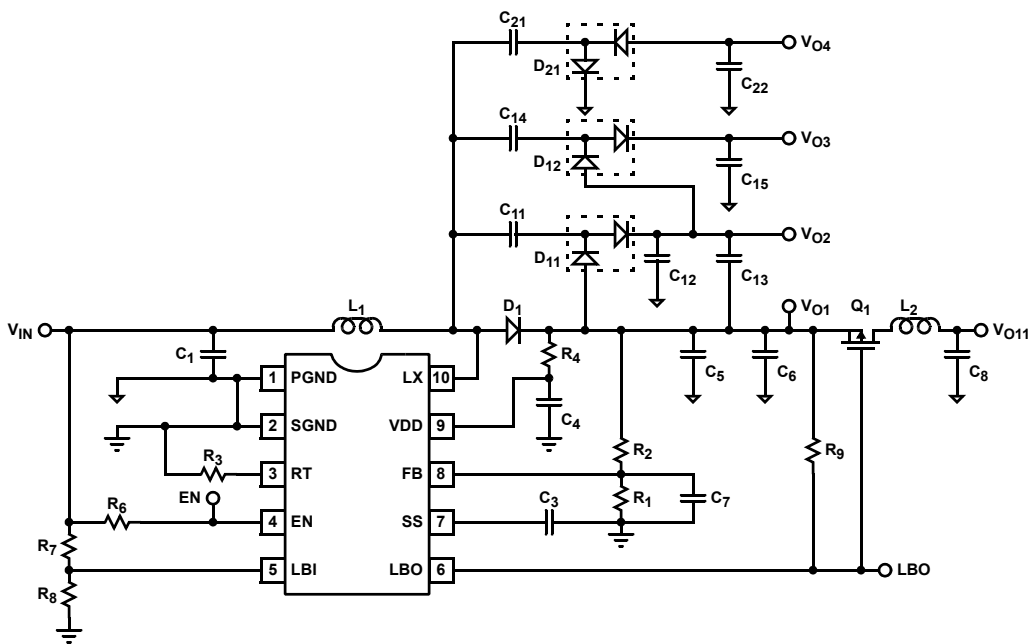

FIGURE 1. COMPLETE SCHEMATIC OF EL7515 DEMO BOARD

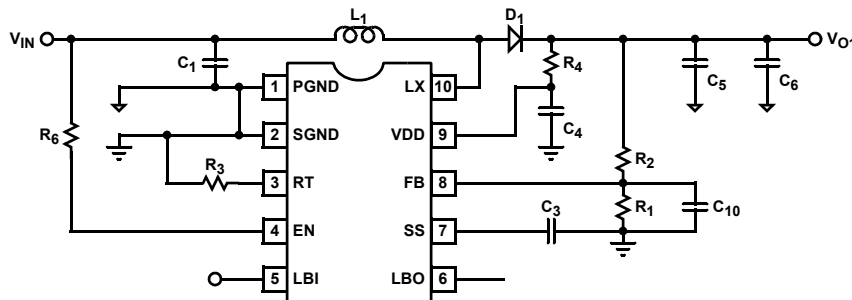

FIGURE 2. 5V TO 12V CONVERTER

EL7515 Bill of Materials for $V_O=12V$ (Figure 2)

$F_S = 670kHz$

REFERENCE DESIGNATOR	VALUE	MANUFACTURER	MANUFACTURER'S PHONE NUMBER	MANUFACTURER'S PART NUMBER
R1	10k Ω /1%, 0603	Any		
R2	82.5k Ω /1%, 0603	Any		
R3	100k Ω , 0603	Any		
R4	1k Ω , 0603	Any		
R6	0 Ω	Any		
C1	10 μ F, 16V, 1206	Murata	1-770-436-1300	GRM31CR61106KC31B
C3	20nF, 0603	Any		
C4	0.1 μ F/16V, 0805	Any		
C5	22 μ F, 16V, 1812	TDK		C4532X5R1C226M
C6	0.1 μ F/16V, 0805	Any		
C10	10nF, 0603	Any		
L1	10 μ H	Coilcraft	847-639-6400	DO1608C-103
D1	MBR0520	On Semiconductor	800-282-9855	MBR0520

EL7515 Bill of Materials for $V_O=18V$ (Figure 2)

$F_S = 1.2MHz$

REFERENCE DESIGNATOR	VALUE	MANUFACTURER	MANUFACTURER'S PHONE NUMBER	MANUFACTURER'S PART NUMBER
R1	10k Ω /1%, 0603	Any		
R2	124k Ω	Any		
R3	47.5k Ω	Any		
R4	2.26k Ω	Any		
R6	0 Ω	Any		
C1	10 μ F, 16V, 1206	Murata	1-770-436-1300	GRM31CR61106KC31B
C3	20nF, 0603	Any		
C4	0.1 μ F/16V, 0805	Any		
C5	22 μ F, 16V, 1812	TDK		C4532X5R1C226M
C6	0.1 μ F/16V, 0805	Any		
C10	10nF	Any		
L1	6.8 μ H	Coilcraft	847-639-6400	DO1608C-682
D1	MBR0520	On Semiconductor	800-282-9855	MBR0520

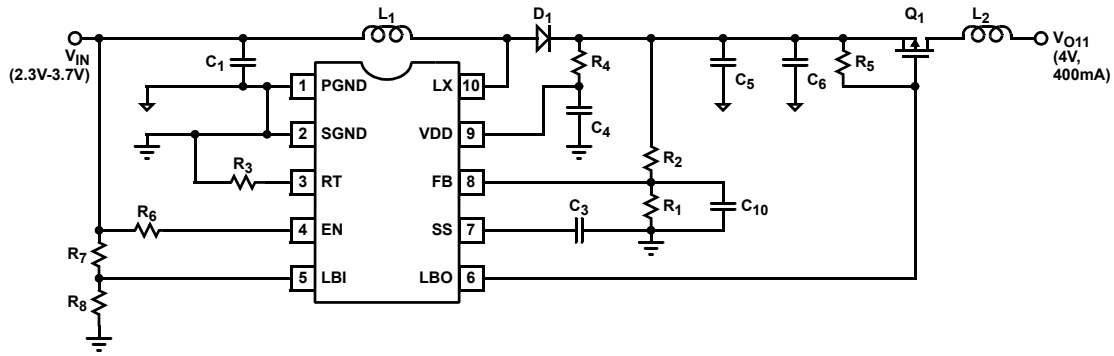

FIGURE 3. EL7515 WITH OUTPUT DISCONNECT

Disconnect voltage at:

$$V_{IN} = 0.22 \times \left(1 + \frac{R_7}{R_8} \right)$$

EL7515 Bill of Materials for $V_O=4V$ (Figure 3)

$F_S = 670kHz$

REFERENCE DESIGNATOR	VALUE	MANUFACTURER	MANUFACTURER'S PHONE NUMBER	MANUFACTURER'S PART NUMBER
R1, R5, R8	10k Ω /1%, 0603	Any		
R2	20k Ω /1%, 0603	Any		
R3	100k Ω , 0603	Any		
R4	51 Ω , 0603	Any		
R6	0 Ω	Any		
R7	56.2k Ω	Any		
C1	10 μ F, 16V, 1206	Murata	1-770-436-1300	GRM31CR61106KC31B
C3	20nF, 0603	Any		
C4	0.1 μ F/16V, 0805	Any		
C5	330 μ F 100 μ F	Vishay/Sprague	207-324-4140	293D476X-020D20
		Murata	1-770-436-1300	GRM43SR60J107M***B
C6	0.1 μ F/16V, 0805	Any		
C10	10nF, 0603	Any		
L1	10 μ H	Coilcraft	847-639-6400	DO1608C-103
L2	0 Ω	Any		
D1	MBR0520	On Semiconductor	800-282-9855	MBR0520
Q1	IRLML6402	IR		IRLML6402

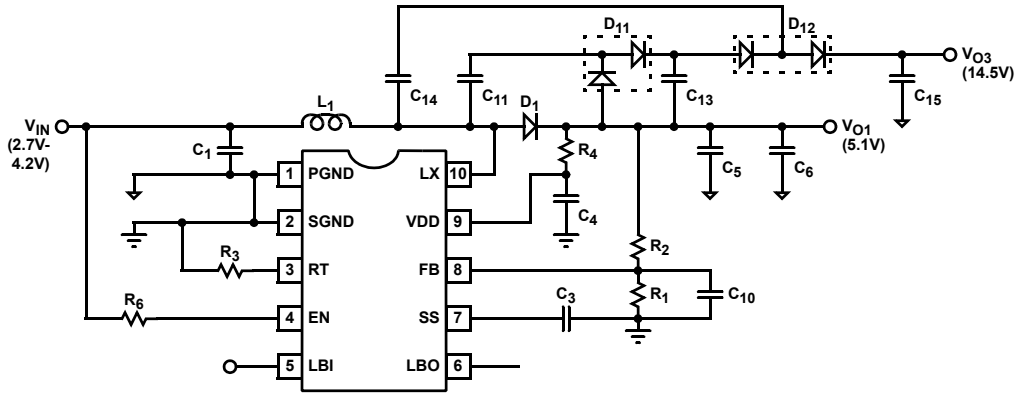

FIGURE 4. EL7515 WITH DUAL OUTPUTS

EL7515 Bill of Materials (Figure 4)

$V_{O1} = 5.1V$, $V_{O3} = 14.5V$, $F_S = 670kHz$

REFERENCE DESIGNATOR	VALUE	MANUFACTURER	MANUFACTURER'S PHONE NUMBER	MANUFACTURER'S PART NUMBER
R1	133k Ω /1%	Any		
R2	402k Ω /1%	Any		
R3	100k Ω	Any		
R4	51 Ω	Any		
R6	0 Ω	Any		
C1	10 μ F, 16V, 1206	Murata	1-770-436-1300	GRM31CR61106KC31B
C3	20nF	Any		
C4, C6, C11, C14	0.1 μ F/16V	Any		
C5	22 μ F, 10V, 1210	Murata	1-770-436-1300	GRM32ER61A226KA65B
C10	10nF, 0603	Any		
C13	1 μ F	Any		
C15	4.7 μ F	Panasonic	408-945-5660	ECJ-3YF1C4752
L1	10 μ H	Coilcraft	847-639-6400	DO1608C-103
D1	MBR0520	On Semiconductor	800-282-9855	MBR0520
D2, D3	BAT54S	Vishay/Telefunken	402-563-6866	BAT54S

Typical Performance Curves

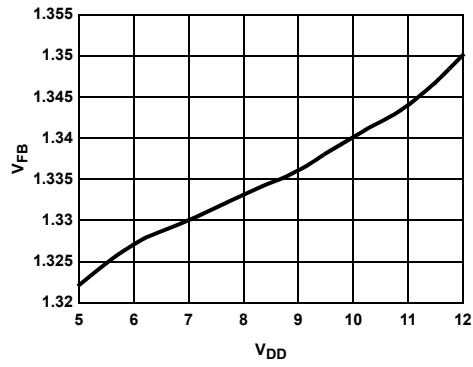

FIGURE 6. V_{FB} vs V_{DD}

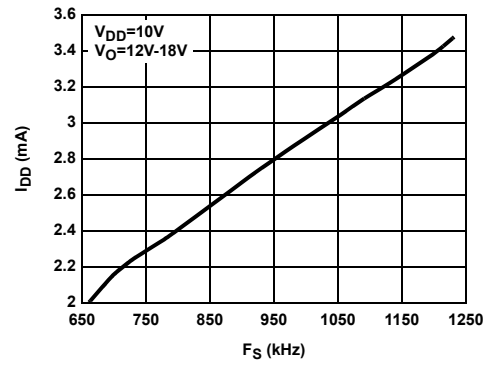

FIGURE 7. I_{DD} vs F_S

Demo Board Layout

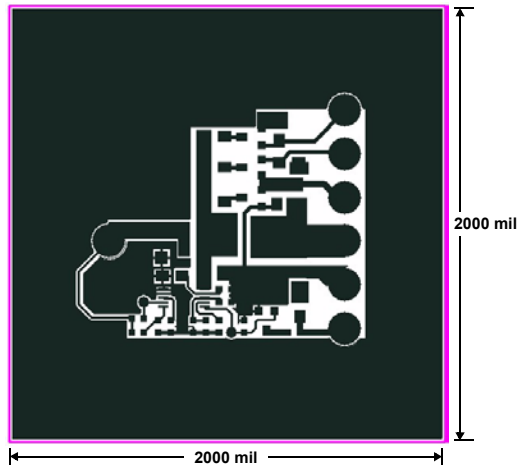

FIGURE 8. TOP LAYER

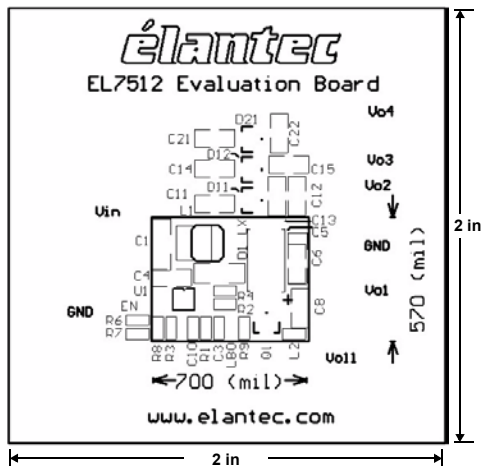

FIGURE 9. TOP SILKSCREEN

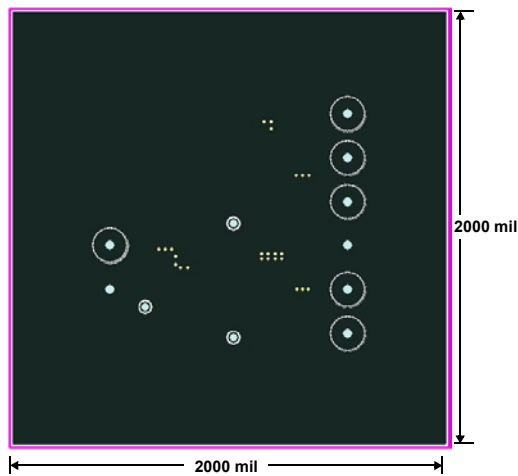

FIGURE 10. BOTTOM LAYER

Intersil Corporation reserves the right to make changes in circuit design, software and/or specifications at any time without notice. Accordingly, the reader is cautioned to verify that the Application Note or Technical Brief is current before proceeding.

For information regarding Intersil Corporation and its products, see www.intersil.com