

## SMALL-SIGNAL COMBINATION IC FOR BLACK-AND-WHITE TV

### GENERAL DESCRIPTION

This IC contains all small-signal functions required for black-and-white tv reception. The only additional circuits needed to complete the receiver are a tuner and the deflection output stages.

The IC includes a vision i.f. amplifier with synchronous demodulator and a.f.c. circuit, an a.g.c. detector with tuner output and fully synchronized vertical and horizontal drive outputs.

Sound signals are demodulated and amplified within the IC in a circuit which includes volume control and internal muting.

The TDA4503 may also be adapted for simple colour tv reception by the use of an external, three-level sandcastle pulse generator.

### Features

- Vision i.f. amplifier with synchronous demodulator
- A.G.C. detector and amplifier with a.g.c. output to tuner
- A.F.C. circuit
- Video preamplifier
- Audio preamplifier
- Sound i.f. amplifier and demodulator
- D.C. volume control
- Horizontal synchronization circuit
- Transmitter identification and mute circuit
- Vertical synchronization circuit and sawtooth generator

### QUICK REFERENCE DATA

Supply voltage (pin 7)	V <sub>7-10</sub>	typ.	10,5 V
Supply current (pin 7)	I <sub>7</sub>	typ.	82 mA
Supply voltage (pin 22)	V <sub>22-10</sub>	typ.	10,5 V
Supply current (pin 22)	I <sub>22</sub>	typ.	5 mA
Operating ambient temperature range	T <sub>amb</sub>		-25 to + 65 °C
Storage temperature range	T <sub>stg</sub>		-25 to +150 °C
Power dissipation	P <sub>tot</sub>	typ.	920 mW

### PACKAGE OUTLINE

28-lead DIL; plastic (with internal heat spreader) (SOT117).

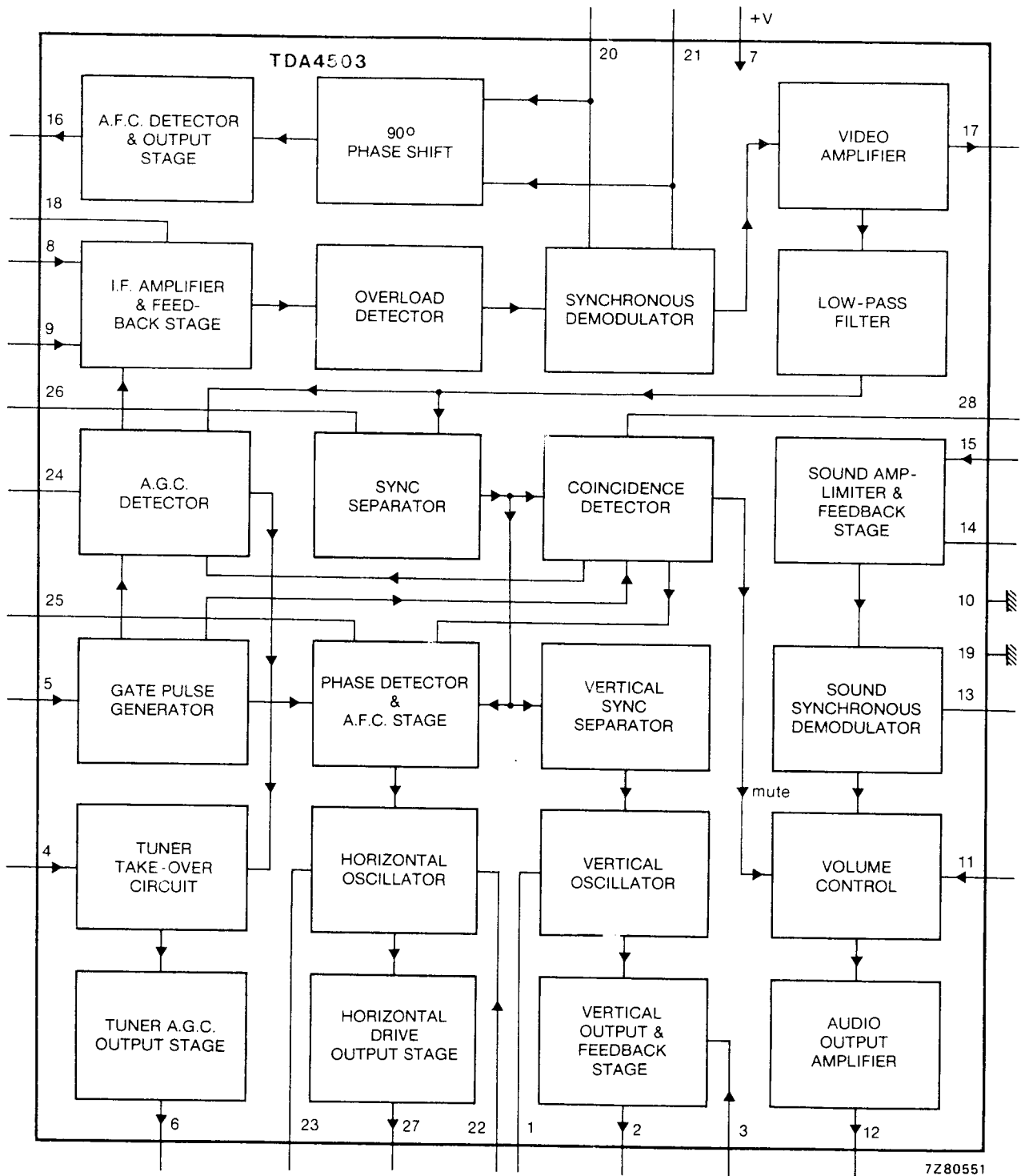

Fig. 1 Block diagram.

**PINNING**

- |                                       |  |
|---------------------------------------|--|
| 1. Vertical oscillator input          | 15. Sound i.f. input                   |
| 2. Vertical drive output              | 16. A.F.C. output                      |
| 3. Vertical drive feedback            | 17. Video output                       |
| 4. Tuner take-over input              | 18. I.F. amplifier decoupling          |
| 5. Flyback pulse input                | 19. Ground (for critical circuits)     |
| 6. A.G.C. output to tuner             | 20. Synchronous demodulator            |
| 7. Power supply input                 | 21. Synchronous demodulator            |
| 8. I.F. input                         | 22. Horizontal oscillator start input  |
| 9. I.F. input                         | 23. Horizontal oscillator              |
| 10. Power supply return (ground)      | 24. A.G.C. time constant               |
| 11. Volume control                    | 25. Horizontal phase detector filter   |
| 12. Audio output                      | 26. Sync separator slicing level       |
| 13. Sound demodulator reference input | 27. Horizontal drive output            |
| 14. Sound i.f. decoupling             | 28. Coincidence detector time constant |

**FUNCTIONAL DESCRIPTION****I.F. amplifier, demodulator and A.F.C.**

The i.f. amplifier operates with symmetrical inputs at pins 8 and 9 and has an input impedance suitable for SAW filter application. The amplifier sensitivity gives a peak-to-peak output voltage of 3 V for an r.m.s. input of 70  $\mu$ V. The demodulator and the a.f.c. circuit share an external reference tuned circuit (pins 20 and 21) and an internal RC-network provides the phase-shifting necessary for a.f.c. operation. The a.f.c. circuit provides a control voltage output with a (typical) swing of 9 V from pin 16 ( $V_p = 10,5$  V).

**A.G.C. circuit**

Gating of the a.g.c. detector is performed to reduce sensitivity of the i.f. amplifier to external electrical noise. The a.g.c. time constant is provided by an RC-network connected to pin 24. The typical gain control range of the i.f. amplifier is 60 dB. Tuner a.g.c. voltage is supplied from pin 6 and is suitable for tuners with pnp or npn RF stages. The sense of the AGC (to increase in a positive or negative direction) and the point of tuner take-over are preset by the voltage level at pin 4 ( $V_4 = 3,5$  V (typ) for positive a.g.c.;  $V_4 = 8$  V (typ) for negative a.g.c.).

**Video amplifier**

The video signal output from pin 17 has a peak-to-peak value of 3 V (top sync level = 1,5 V) and carries negative-going sync. In order to retain sound information at pin 17, the video signal is not blanked during flyback periods.

**Sound circuit**

The sound i.f. signal present at the video output (pin 17) is coupled to the sound circuit by a band-pass filter to pin 15. The sound circuit has an amplifier-limiter stage, a synchronous demodulator with reference tuned circuit at pin 13, a volume control stage and an output amplifier. The volume control has a range of approximately 80 dB and the audio output signal at maximum volume and with  $\Delta f = 7,5$  kHz is 320 mV (r.m.s. value). The sound output signal is suppressed when no input signal is detected.

**Synchronization circuits**

The sync separator slicing level is determined by an external resistor network at pin 26. The slicing level is referred to the top sync level and the recommended value for slicing is 30%. Internal protection from electrical noise is included.

A gated phase detector compares the phase of the separated sync pulses with a sawtooth waveform obtained from the flyback pulse at pin 5. In-sync and out-of-sync conditions are detected by the coincidence detector at pin 28 (this circuit also gives transmitter identification). During the out-of-sync condition, gating of the phase detector is switched off and the output current from the phase detector increases to give the detector a short time-constant and thus a fast response. This condition can be imposed by clamping the voltage at pin 28 to 3,5 V for the reception of VCR signals.

The horizontal oscillator frequency is controlled by the output voltage of the phase detector circuit. The horizontal drive output from pin 27 has a duty factor of 40%.

Vertical sync pulses are separated by an internal integrating network and are used to trigger the vertical oscillator. A comparator circuit compares the vertical sawtooth waveform, generated by the vertical oscillator, with feedback from the deflection coils and supplies the drive voltage for the output stage at pin 2.

**Power supplies**

The main supply is to pin 7 (positive supply) and pin 10 (ground). The horizontal oscillator is supplied from pin 22 to facilitate starting of the oscillator from a high-voltage rail. A special ground connection at pin 19 is used by critical voltage dividers in the feedback loops of the vision and sound i.f. circuits.

**RATINGS**

Limiting values in accordance with the Absolute Maximum System (IEC 134)

Supply voltage (pin 7)	$V_P = V_{7-10}$	max.	13,2 V
Total power dissipation	$P_{tot}$	max.	1,7 W
Operating ambient temperature range	$T_{amb}$		-25 to + 65 °C
Storage temperature range	$T_{stg}$		-25 to +150 °C

**CHARACTERISTICS** $V_{7-10} = 10,5$  V;  $V_{22-10} = 10,5$  V;  $T_{amb} = 25$  °C; unless otherwise specified

parameter	symbol	min.	typ.	max.	unit
<b>Supplies</b>					
Supply voltage (pin 7)	$V_{7-10}$	9,5	10,5	13,2	V
Supply current (pin 7)	$I_7$	—	82	100	mA
Supply voltage (pin 22)	$V_{22-10}$	9,5	10,5	13,2	V
Supply current (pin 22) ( note 1)	$I_{22}$	—	5	6,5	mA
Total power dissipation	$P_{tot}$	—	920	1150	mW
<b>Vision i.f. amplifier (pins 8 and 9)</b>					
Input sensitivity at 38,9 MHz (note 2)	$V_{8-9}$	40	80	120	$\mu$ V
Input sensitivity at 45,75 MHz (note 2)	$V_{8-9}$	—	90	—	$\mu$ V
Differential input resistance (pin 8 to 9)	$R_{8-9}$	—	1,3	—	k $\Omega$
Differential input capacitance (pin 8 to 9)	$C_{8-9}$	—	5	—	pF
A.G.C. range		—	59	—	dB
Maximum input signal	$V_{8-9}$	50	70	—	mV
Expansion of output signal (pin 17) for 50 dB variation of input signal (pins 8 and 9) (note 3)	$\Delta V_{17-10}$	—	0,5	1,0	dB
<b>Video amplifier (note 4)</b>					
Output level for zero signal input (zero point of switched demodulator)	$V_{17-10}$	4,2	4,5	4,8	V
Output signal top sync level (note 5)	$V_{17-10}$	1,25	1,45	1,65	V

## CHARACTERISTICS (continued)

parameter	symbol	min.	typ.	max.	unit
Amplitude of video output signal (peak-to-peak value)	$V_{17-10(p-p)}$	2,4	2,7	3,0	V
Internal bias current of output transistor (npn emitter follower)	$I_{17(int)}$	1,4	2,0	—	mA
Bandwidth of demodulated output signal	B	—	5	—	MHz
Differential gain (Fig. 4 and note 6)	G <sub>17</sub>	—	6	—	%
Differential phase (Fig. 4 and note 6)		—	4	—	%
Video non-linearity over total video amplitude (peak white to black)		—	—	10	%
Intermodulation (Figs 5 and 6) at gain control = 45 dB					
f = 1,1 MHz; blue;		55	60	—	dB
f = 1,1 MHz; yellow;		50	54	—	dB
f = 3,3 MHz; blue;		60	66	—	dB
f = 3,3 MHz; yellow;		55	59	—	dB
Signal-to-noise ratio (note 7) at $V_i = 10$ mV	S/N	50	54	—	dB
at end of a.g.c. range	S/N	50	56	—	dB
as a function of input signal		see Fig. 7			
Residual A.M. of intercarrier output signal (note 8)		—	5	10	%
Residual carrier signal		—	7	30	mV
Residual 2nd harmonic of carrier signal		—	3	30	mV
<b>Tuner a.g.c. (note 9)</b>					
Take-over voltage (pin 4) for positive-going tuner a.g.c. (NPN tuner)	$V_{4-10}$	—	3,5	—	V
Starting point take-over at $V_{4-10} = 5$ V (r.m.s. value)	$V_{8-9(rms)}$	—	0,4	2,0	mV
Starting point take-over at $V_{4-10} = 1,2$ V (r.m.s. value)	$V_{8-9(rms)}$	50	70	—	mV
Take-over voltage (pin 1) for negative-going tuner a.g.c. (PNP tuner)	$V_{4-10}$	—	8	—	V
Starting point take over at $V_{4-10} = 9,5$ V (r.m.s. value)	$V_{8-9(rms)}$	—	0,3	2,0	mV
Starting point take over at $V_{4-10} = 5,6$ V (r.m.s. value)	$V_{8-9(rms)}$	50	70	—	mV
Maximum tuner a.g.c. output swing	$I_{6max}$	2	3	—	mA
Output saturation voltage at $I_6 = 2$ mA	$V_{6-10(sat)}$	—	—	300	mV
Leakage current at pin 6	$I_6$	—	—	1	$\mu$ A
Input signal variation required for complete tuner control	$\Delta V_{8-9}$	0,5	2	4	dB

parameter	symbol	min.	typ.	max.	unit
<b>A.F.C. circuit (pin 16; note 10)</b>					
A.F.C. output voltage swing (peak-to-peak value)	$V_{16-10(p-p)}$	9	—	10	V
Available output current	$\pm I_{16}$	—	1	—	mA
Control steepness at					
100% picture carrier		20	40	80	mV/kHz
10% picture carrier		—	15	—	mV/kHz
Output voltage at nominal tuning of the reference tuned circuit	$V_{16-10}$	—	5,25	—	V
Output voltage without input signal	$V_{16-10}$	2,7	6,0	8,5	V
<b>Sound circuit</b>					
Input limiting voltage (note 11) (r.m.s. value) at $V_O = V_{O \max} - 3 \text{ dB}$	$V_{15 \text{ lim}}$	—	2	—	mV
Input resistance at $V_i(\text{rms}) = 1 \text{ mV}$	$R_{15-10}$	—	2,6	—	k $\Omega$
input capacitance at $V_i(\text{rms}) = 1 \text{ mV}$	$C_{15-10}$	—	6	—	pF
A.M. rejection (Figs 8 and 9) at					
$V_i = 10 \text{ mV}$	AMR	—	35	—	dB
$V_i = 50 \text{ mV}$	AMR	—	43	—	dB
A.F. output signal (note 12) (r.m.s. value)	$V_{12-6(\text{rms})}$	220	320	—	mV
A.F. output impedance	$Z_{12-10}$	—	150	—	$\Omega$
Total harmonic distortion (note 12)	THD	—	1	—	%
Ripple rejection at					
$f_k = 100 \text{ Hz}$ , volume control 20 dB when muted	RR	—	22	—	dB
	RR	—	26	—	dB
Output voltage in mute condition	$V_{12-10}$	—	2,6	—	V
Signal-to-noise ratio; weighted noise (CCIR 468)	S/N	—	47	—	dB
<b>Volume control</b>					
Voltage (pin 11 disconnected)	$V_{11-10}$	—	6,9	—	V
Current (pin 11 connected to ground)	$I_{11}$	—	1	—	mA
External control resistor (note 13)	$R_{11-10}$	—	5	—	k $\Omega$
Suppression of output signal during mute condition		—	66	—	dB

## CHARACTERISTICS (continued)

parameter	symbol	min.	typ.	max.	unit
<b>Horizontal synchronization</b>					
Slicing level sync separator (note 14)		—	30	—	%
Phase-lock loop holding range		±800	±1100	±1500	Hz
Phase-lock loop catching range		±600	1000	—	Hz
Control sensitivity video to flyback (note 15)		—	2,3	—	kHz/μs
Delay between leading edge of sync pulse and zero cross-over of sawtooth (pin 5)		—	3	—	μs
<b>Horizontal oscillator (pin 23)</b>					
Free-running frequency R = 35 kΩ; C = 2,7 nF	f <sub>fr</sub>	—	15625	—	Hz
Spread with fixed external components		—	—	4	%
Frequency variation due to change of supply voltage from 8 to 12 V	Δf <sub>fr</sub>	—	0	0,5	%
Temperature coefficient	TC	—	—	1×10 <sup>-4</sup>	K <sup>-1</sup>
Maximum frequency shift	Δf <sub>fr</sub>	—	—	10	%
Maximum frequency deviation (V <sub>7-10</sub> = 8 V)	Δf <sub>fr</sub>	—	—	10	%
<b>Horizontal output (pin 27)</b>					
Output current	I <sub>27</sub>	5	—	—	mA
Output impedance	R <sub>27</sub>	—	200	—	Ω
Output voltage at I <sub>27</sub> = 5 mA	V <sub>27-10</sub>	—	1,4	—	V
	V <sub>27-22</sub>	—	2,5	—	V
Duty factor of horizontal output signal (note 16)	α	0,35	0,40	0,45	%
Rise and fall times of output pulse	t <sub>r,tf</sub>	—	400	—	ns
<b>Flyback input (pin 5)</b>					
Amplitude of input pulse	V <sub>5</sub>	2	4	6	V
Voltage at which gate pulse generator changes state (note 17)	V <sub>5</sub>	—	0	—	V



parameter	symbol	min.	typ.	max.	unit
<b>Coincidence detector mute output</b> (pin 28) (note 18)					
Voltage for in-sync condition	V <sub>28-10</sub>	—	9,5	—	V
Voltage for no-sync condition (no input signal)	V <sub>28-10</sub>	—	1,0	1,5	V
Voltage level for phase detector to switch from slow to fast	V <sub>28-10</sub>	3,7	4,1	4,5	V
Fast-to-slow hysteresis		—	1	—	V
Voltage level to activate mute function (transmitter identification)	V <sub>28-10</sub>	2,25	2,5	2,75	V
Output current for in-sync condition (peak-to-peak value)	I <sub>22(p-p)</sub>	0,7	1,0	—	mA
<b>Vertical oscillator</b> (pin 1)					
Free-running frequency at C = 220 nF; R = 560 kΩ	f <sub>fr</sub>	—	47,5	—	Hz
Spread with fixed external components		—	—	4	%
Holding range at nominal frequency		52,5	—	—	Hz
Temperature coefficient	TC	—	—	2x10 <sup>-4</sup>	K <sup>-1</sup>
Frequency variation due to change of supply voltage from 9,5 to 12 V	Δf <sub>fr</sub>	—	3	5	%
Leakage current at pin 1	I <sub>1</sub>	—	—	1,6	μA
<b>Vertical output</b> (pin 2)					
Output current	I <sub>2</sub>	1	1,3	—	mA
Output resistance	R <sub>2</sub>	—	2	—	kΩ
<b>Feedback input</b> (pin 3)					
Input voltage					
d.c. component	V <sub>3-10</sub>	4,0	5,0	5,5	V
a.c. component (peak-to-peak value)	V <sub>3-10(p-p)</sub>	—	1,2	—	V
Input current	I <sub>3</sub>	—	—	12	μA
Non-linearity of deflection current at V <sub>7-10</sub> = 10,5 V	ΔI <sub>3</sub>	—	—	2,5	%
Delay between leading edge of vertical sync and start of vertical oscillator flyback		6	—	10	μs

## Notes to the characteristics

1. The horizontal oscillator can be started by supplying a current of 6 mA to pin 22. Taking this current from the mains rectifier allows the positive supply voltage to pin 7 to be derived from the horizontal output stage (the load current of pin 27 is additional to the 6 mA quoted).
2. At start of a.g.c.
3. Measured with 0 dB = 200  $\mu$ V.
4. Measured at 10 mV (rms) top sync output signal.
5. Signal with negative-going sync; top white = 10% of the top sync amplitude.
6. Measured with test line as shown in Fig. 4. The differential gain is expressed as a percentage of the difference in peak amplitudes between the largest and smallest values relative to the subcarrier amplitude at blanking level. The differential phase is defined as the difference in degrees between the largest and smallest phase angles.
7. Measured with a source impedance of 75  $\Omega$ .  

$$\text{Signal-to-noise ratio} = 20 \log \frac{V_O \text{ black-to-white}}{V_{i(\text{rms})} \text{ at } B = 5 \text{ MHz}}$$
8. Measured with a sawtooth-modulated input signal:  $m = 90\%$ ;  $V_{i(\text{rms})} = 10 \text{ mV}$ ;  

$$\text{Amplitude modulation} = \frac{V_O \text{ SC at top sync} - V_O \text{ SC at white}}{V_O \text{ SC at top sync} + V_O \text{ SC at white}} \times 100\%.$$

(SC = sound carrier)
9. Starting point of tuner take-over for an npn tuner is when  $I_G = 1,8 \text{ mA}$ , and for a pnp tuner is when  $I_G = 0,2 \text{ mA}$ .
10. Measured at  $V_{8,9(\text{rms})} = 10 \text{ mV}$  and pin 16 loaded with  $2 \times 100 \text{ k}\Omega$  between  $V_7$  and ground. Reference tuned circuit Q-factor = 36.
11. Reference tuned circuit Q-factor = 16; audio frequency = 1 kHz; carrier frequency = 5,5 MHz.
12. The demodulator tuned circuit must be tuned for minimum distortion; output signal is measured at  $\Delta f = 7,5 \text{ kHz}$ ; other measurements are at  $\Delta f = 27,5 \text{ kHz}$ .
13. Volume control can be realized by a variable resistor (5 k $\Omega$ ) connected between pin 11 and ground, or by a variable voltage direct to pin 11 (the low value of input impedance to pin 11 must be taken into account).
14. The sync separator is noise-gated; the slicing level is referred to the top sync level and is independent of the video signal. The value stated is a percentage of the sync pulse amplitude, the level being dependent on external resistors connected to pin 26.
15. The phase detector current is increased by a factor of 7 during catching and when the phase detector is switched to 'fast' via pin 28, thus ensuring a wide catching range and a high dynamic loop gain.
16. The negative-going edge initiates switching-off of the line output transistor (simultaneous driver).
17. The circuit requires an integrated flyback pulse. Gate pulses for a.g.c. and coincidence detectors are obtained from the sawtooth waveform.
18. The functions of in-sync, out-of-sync and transmitter identification are combined on pin 28. For the reception of VCR signals,  $V_{28}$  must be fixed between 3 V and 4,5 V so that the time constant is fast and sound information is preserved.

APPLICATION INFORMATION

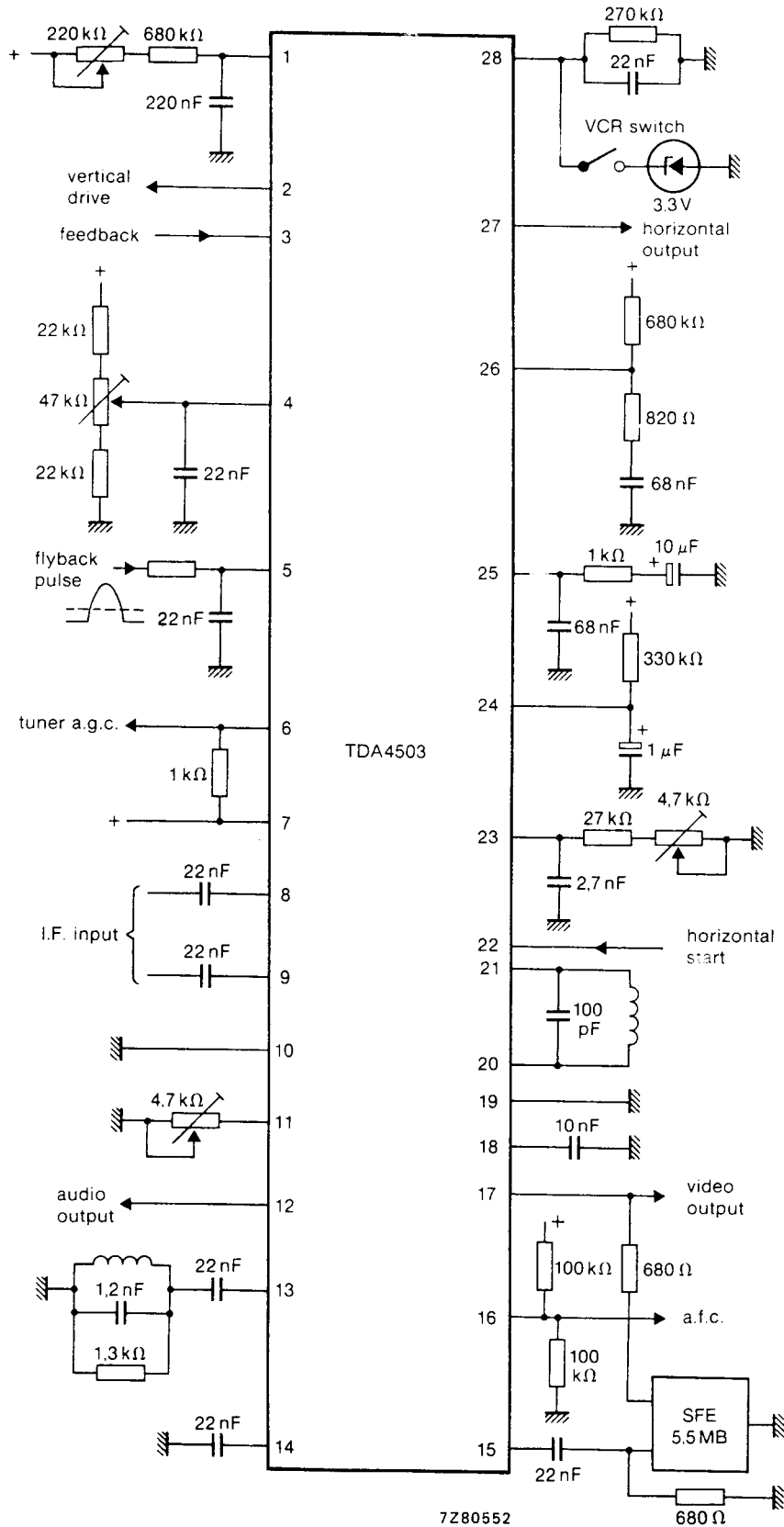

Fig. 2 Application circuit diagram.

APPLICATION INFORMATION (continued)

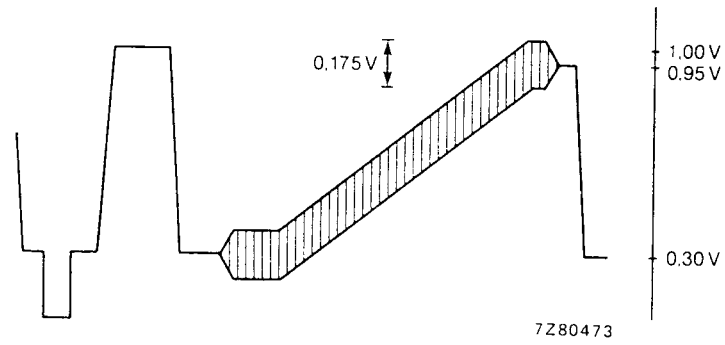

Fig. 3 Video output signal.

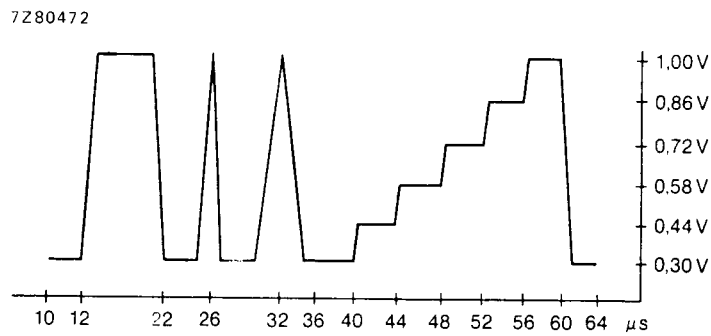

Fig. 4 E.B.U. test signal - line 330.

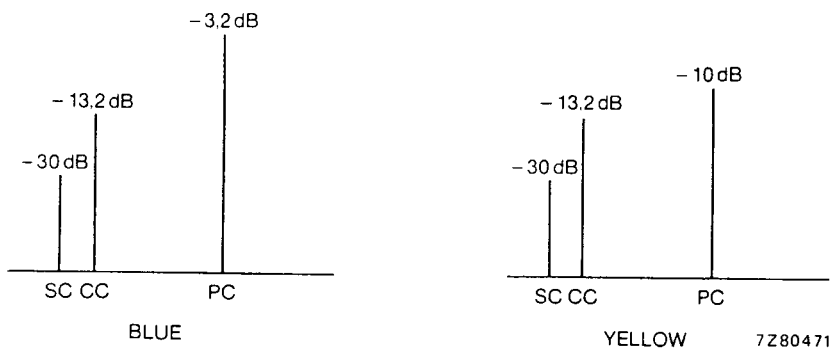

Fig. 5 Input signal conditions for intermodulation test: SC = sound carrier; CC = chrominance carrier; PC = picture carrier; all values are with respect to the top sync level.

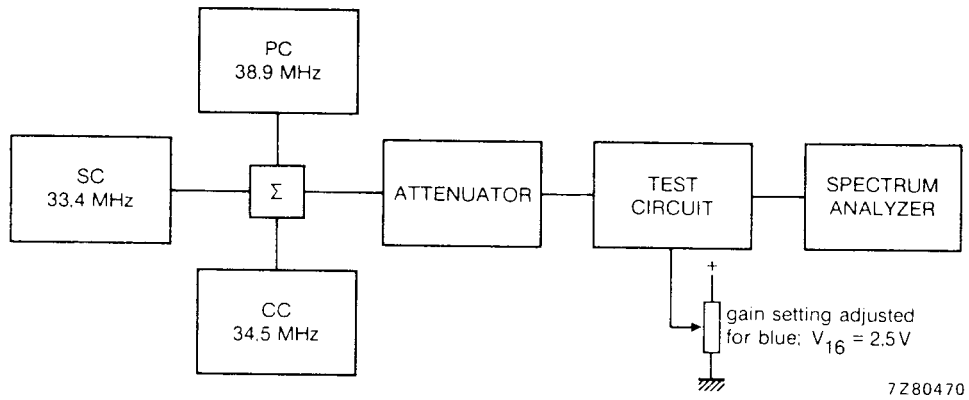

Fig. 6 Circuit for intermodulation test:

$$\text{value at 1,1 MHz} = 20 \log \frac{V_O \text{ at 4,4 MHz}}{V_O \text{ at 1,1 MHz}} + 3,6 \text{ dB};$$

$$\text{value at 3,3 MHz} = 20 \log \frac{V_O \text{ at 4,4 MHz}}{V_O \text{ at 3,3 MHz}} .$$

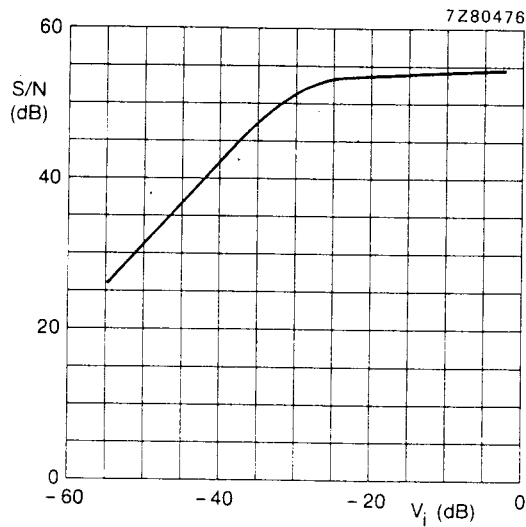
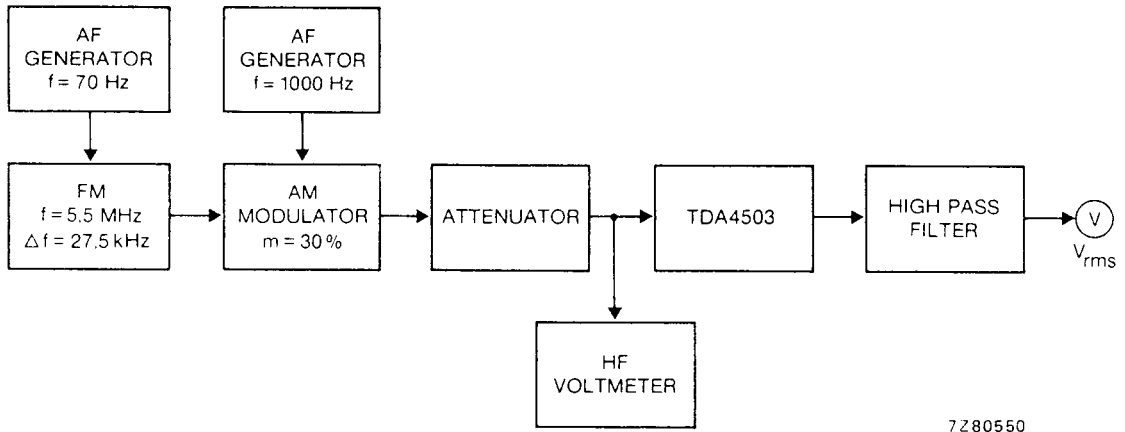

Fig. 7 Signal-to-noise ratio as a function of input voltage.

APPLICATION INFORMATION (continued)



7Z80550

Fig. 8 Circuit for amplitude modulation rejection test.

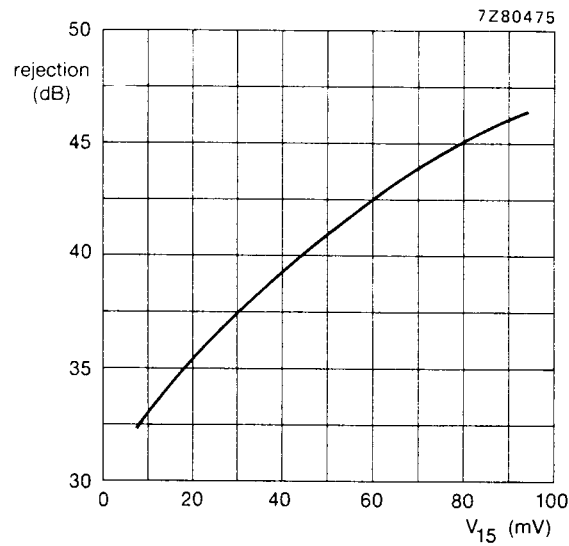

Fig. 9 Typical amplitude modulation rejection curve.

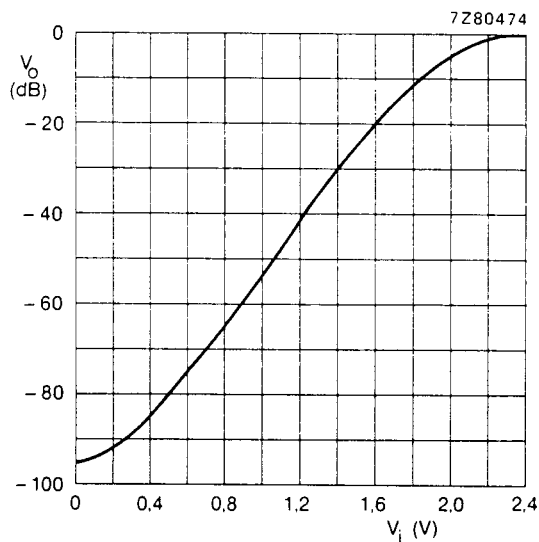

Fig. 10 Volume control characteristic.