

TELE FILTER tft GmbH**SAW filter specification****TFS 246H2 1/4****Measurement condition**

Ambient temperature: 23 °C
 Input power level: -10 dBm
 Source impedance: 490 Ω || -2.62 pF (± 10%)
 Load impedance: 490 Ω || -2.62 pF (± 10%)
 Ext coil: 82 nH

Construction

see page 2

Characteristics

Remark:

Reference level for the relative attenuation a_{rel} of the TFS 246 H2 is the minimum of the pass band attenuation a_{min} . The minimum of the pass band attenuation a_{min} is defined as the insertion loss a_e . The nominal frequency f_N is fixed on 246,000 MHz without tolerance.

Data

		typ. value	tolerance / limit
Insertion loss (Reference level)	$a_e = a_{min}$	2,5 dB	max 5 dB
Nominal frequency	f_N	-	246,000 MHz
Pass band ripple $f_N - 85$ kHz ... $f_N + 93$ kHz		-	max 1,5 dB
Relative attenuation	a_{rel}		
246,0 MHz ± 120 kHz		1,5 dB	max 3 dB
246,0 MHz ± 330 kHz ... 246,0 MHz ± 400 kHz		22 dB	min 18 dB
246,0 MHz ± 400 kHz ... 246,0 MHz ± 600 kHz		33 dB	min 25 dB
246,0 MHz ± 600 kHz ... 246,0 MHz ± 800 MHz		50 dB	min 40 dB
246,0 MHz ± 800 kHz ... 246,0 MHz ± 1,6 MHz		55 dB	min 45 dB
246,0 MHz ± 1,6 MHz ... 246,0 MHz ± 3,0 MHz		55 dB	min 45 dB
246,0 MHz ± 3,0 MHz ... 246,0 MHz ± 20 MHz		55 dB	min 50 dB
246,0 MHz ± 20 MHz ... 246,0 MHz ± 100 MHz		55 dB	min 45 dB
Group delay distortion	GDD		
246,0 MHz ± 50 kHz		0,5 μs	max 1,2 μs
246,0 MHz ± 70 kHz		0,8 μs	max 1,5 μs
246,0 MHz ± 100 kHz		1,2 μs	max 2,5 μs
Operating temperature range		- 20 °C ... + 70 °C	
Storage temperature range		- 30 °C ... + 85 °C	
Temperature coefficient of frequency	TC_f	- 0,036 ppm/K ²	-
Frequency inversion temperature		+ 25 °C	

TELE FILTER tft GmbH / Potsdamer Straße 18 / D 14 513 TELTOW

Phone: (+33 28) 47 84 52 / Facsimile: (+33 28) 47 84 30 / e-mail: tft@tft.telco-tech.de

Construction and pin configuration
(All dimensions in mm)

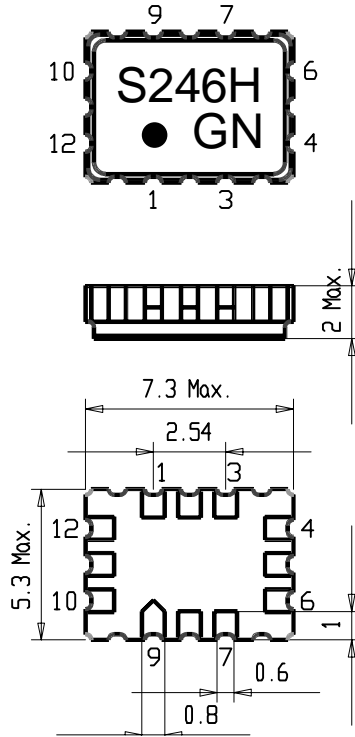

- 1 Output 2 Output
- 3 Ground 4 ext. Coil
- 5 Ground 6 Ground
- 7 Input 8 Input
- 9 Ground 10 Ground
- 11 Ground 12 Ground

50 Ohm Test circuit 1

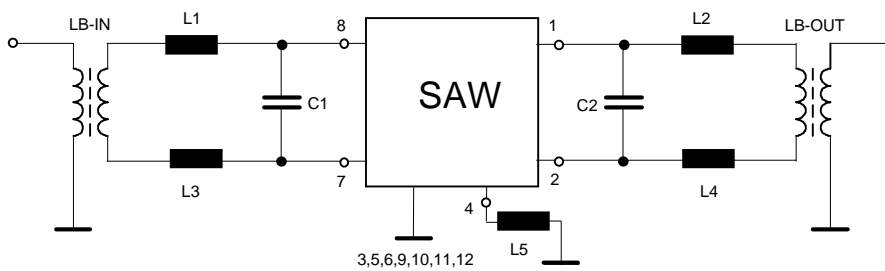

50 Ohm Test circuit 2

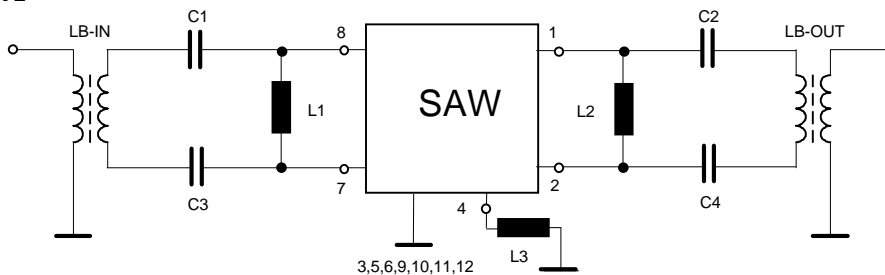

Stability characteristics

After the following tests the filter shall meet the whole specification:

- 1. Shock: 30g, 18 ms, half sine wave, 3 shocks each plane;
IEC 68 - 2 - 27
- 2. Vibration: 10 Hz to 150 Hz, 0.35 mm amplitude, 5g; 2 hours for 3 planes;
IEC 68 - 2 - 6
- 3. Damp heat: 90 % to 95 % rel. humidity, 40 °C, 10 days;
IEC 68 - 2 - 3
- 4. Resistance to solder heat (Reflow): 260 °C for 10 sec;

Packing

Tape & Reel: IEC 286 - 3, with exception of value for N and minimum bending radius;
tape type II, embossed carrier tape with top cover tape on the upper side;
max. pieces of filters per reel: 3400

Tape (all dimensions in mm)

- W : 16 ± 0,3
- Po : 4 ± 0,1
- Do : 1,5 ± 0,5
- D1 : 1,5 ± 0,5
- E : 1,75 ± 0,1
- F : 7,5 ± 0,1
- G (min) : 0,75
- P2 : 2 ± 0,05
- P1 : 8 ± 0,1
- D1(min) : 1,5
- Ao : 5,4 ± 0,1
- Bo : 7,4 ± 0,1

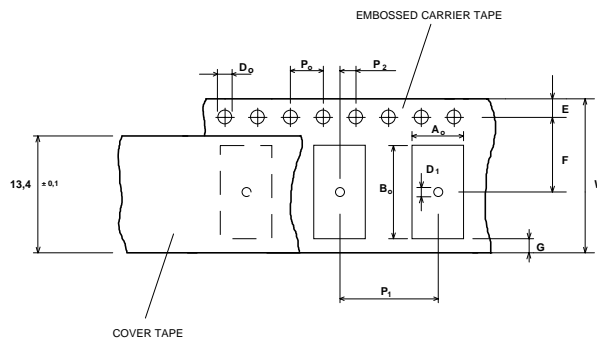

Reel (all dimensions in mm):

- A : 330
- W1 : 16,4 +2
- N (max) : 22,4
- N (min) : >= 90
- C : 13 ± 0,25

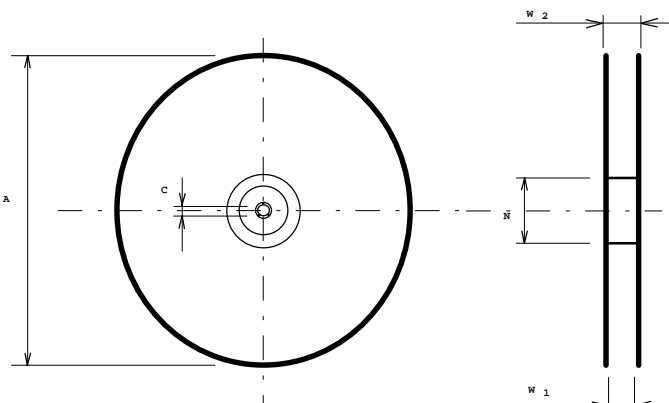

The minimum bending radius is 45 mm. The mounting surface of the filters faces the bottom side of the embossed carrier tape. The marking of the filters is able to read if the view is directed on the upper side of the carrier tape with the sprocket holes on the right side of the tape.

Air reflow temperature conditions

1st and 2nd air reflow profile

Name:	pre-heating periods	main-heating periods	peak temperature
Temperature:	150 °C - 170 °C	over 200 °C	255 °C ± 5 °C
Time:	60 sec. - 90 sec.	20 sec. - 25 sec.	

Chip-mount air reflow profile

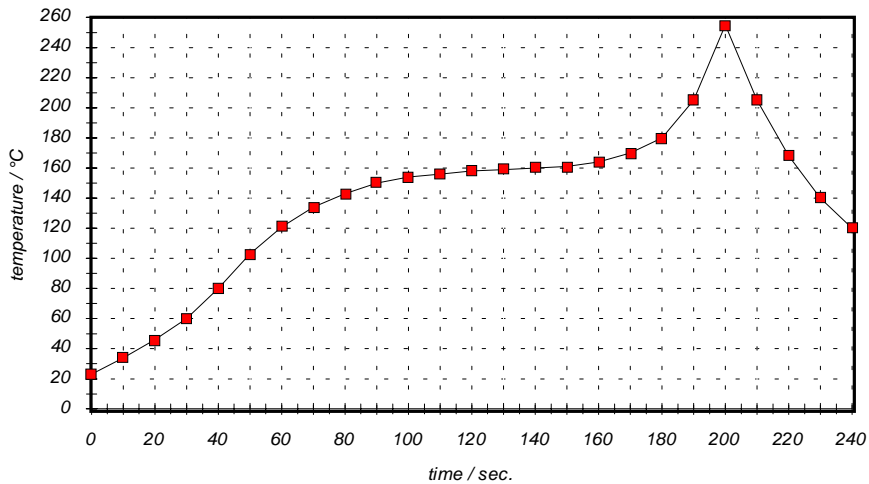

Table for temperature vs. time during the air reflow process

Tolerance of temperatures: ± 5 °C

time / sec.	temperature / °C	time / sec.	temperature / °C
0	23	140	160
10	34	150	161
20	46	160	164
30	60	170	170
40	80	180	180
50	103	190	205
60	121	195	230
70	134	200	255
80	143	205	230
90	150	210	205
100	154	215	180
110	156	220	165
120	158	230	140
130	159	240	120