

**23 - 29 GHz High Power Amplifier**

**TGA1088-EPU**

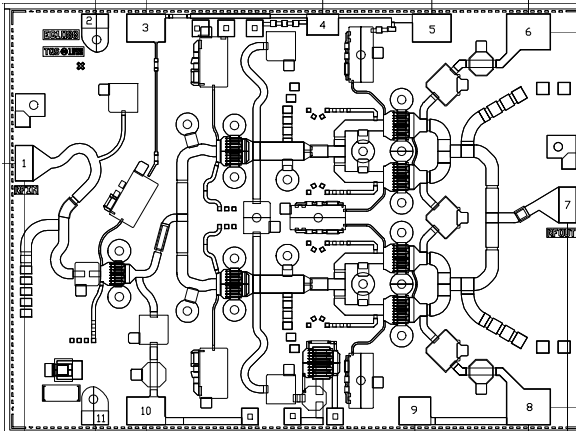

**Key Features and Performance**

- 0.25um pHEMT Technology
- 23 GHz - 29 GHz Frequency Range
- Nominal 1 Watt (28GHz) @ P1dB
- Nominal Gain of 23 dB
- OTOI 38 dBm typical (Linear Mode)
- Bias 7V @ 400 mA Idq (Sat Power mode)
- Bias 7V @ 650 mA Idq (Linear mode)
- Chip Dimensions 4.115mm x 3.047mm

**Primary Applications**

- LMDS
- Point-to-Point Radio

The TriQuint TGA188-EPU is a three stage HPA MMIC design using TriQuint's proven 0.25 um Power pHEMT process to support a variety of millimeter wave applications including point-to-point digital radio, LMDS/LMCS and Ka-band satellite spacecraft and ground terminals.

The three stage design consists of a 400 um input device driving a pair of 600 um interstage devices followed by four 600 um output devices. The device is identical to TriQuint's TGA9070 with the exception of additional bias circuitry that allows the flexibility to operate in two different modes. The high saturated power mode will give identical performance to the TGA9070. The high linearity mode will provide 2-3dB improvement in OTOI performance over the TGA9070.

The TGA1088 provides greater than 1W of output power across 23-29 GHz with a typical PAE of 35%. Typical small signal gain is 23 dB. The device may be biased for either high saturated power or high linearity via bond wire jumpers.

The TGA188 requires minimum off-chip components. Each device is 100% DC and RF tested on-wafer to ensure performance compliance. The device is available in chip form.

TGA 1088 Typical Small Signal Gain

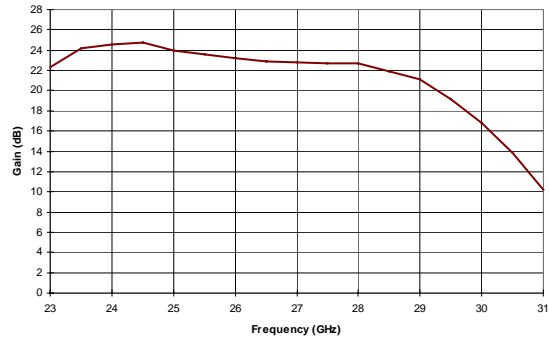

TGA 1088 Typical Saturated Output Power  
Biased in High Saturated Power Mode

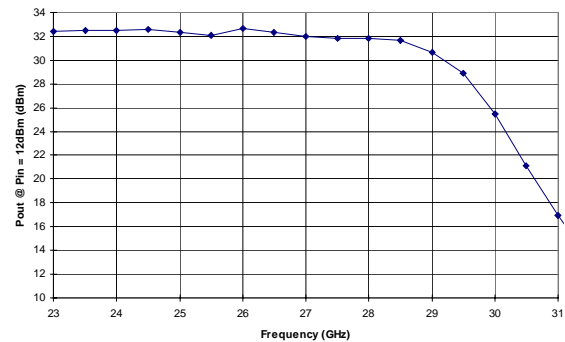

Note: Devices designated as EPU are typically early in their characterization process prior to finalizing all electrical and process specifications. Specifications are subject to change without notice.

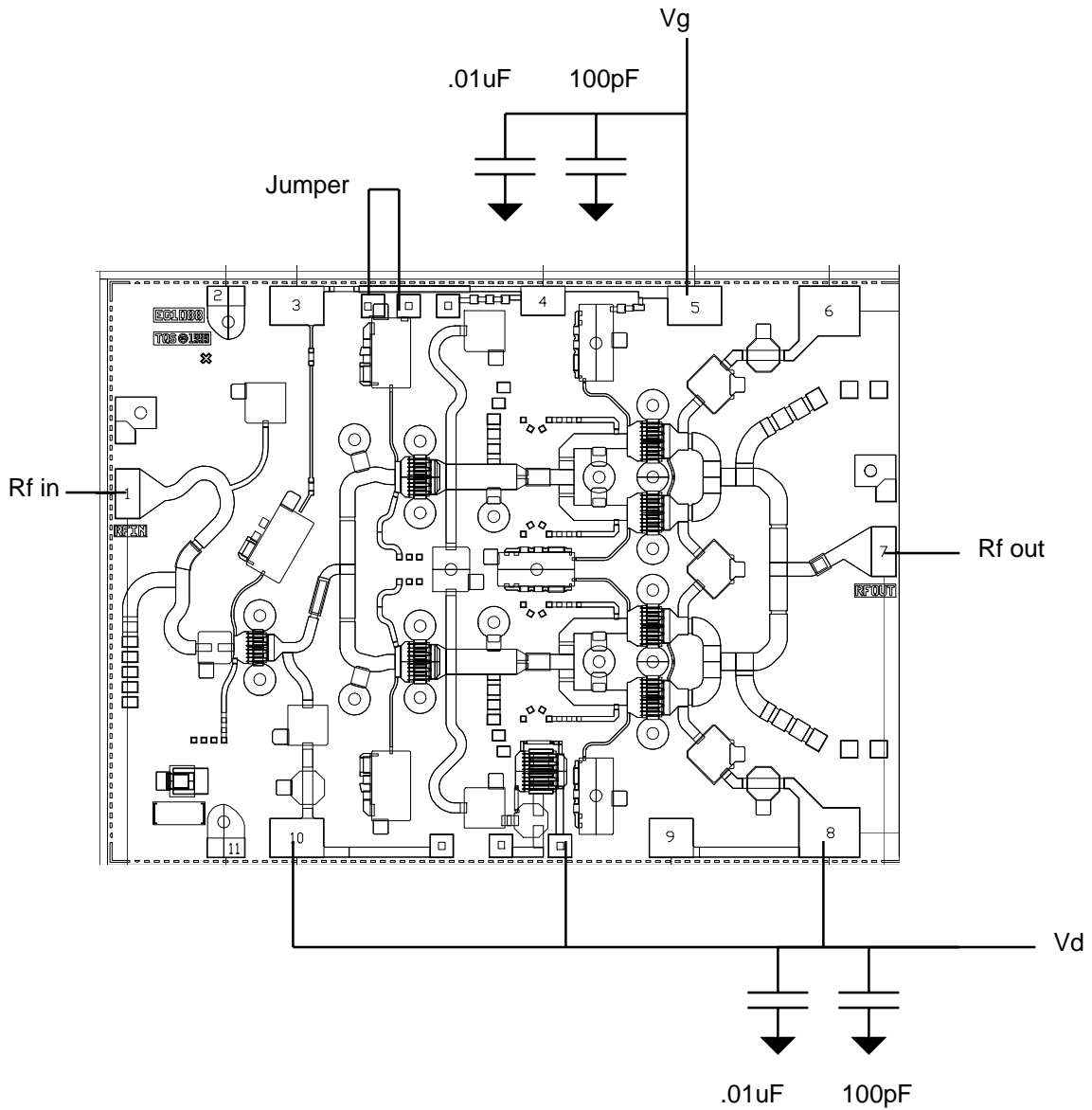

**TGA1088 Bias Connection for High linearity Mode**

*Note: Devices designated as EPU are typically early in their characterization process prior to finalizing all electrical and process specifications. Specifications are subject to change without notice.*

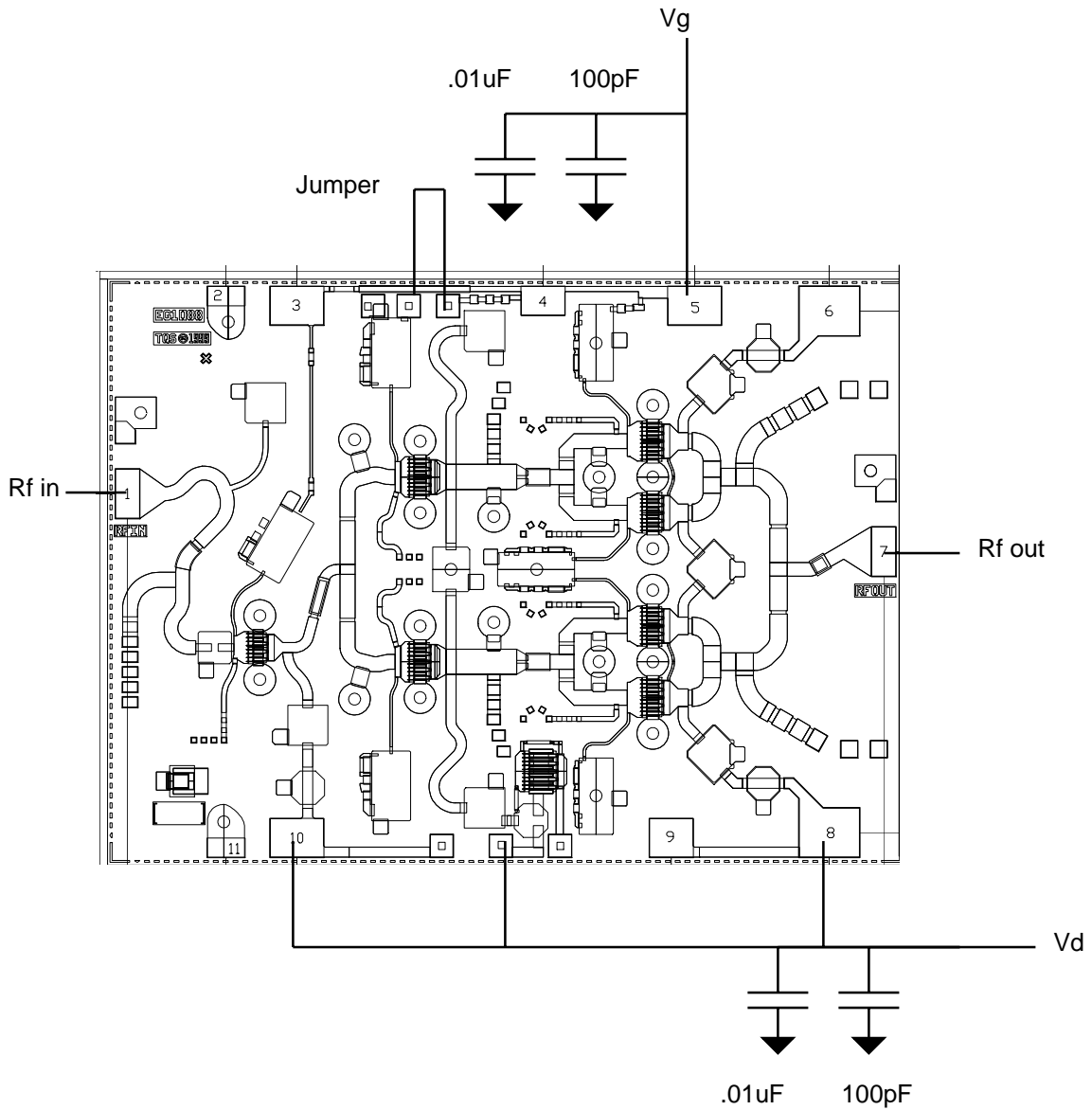

**TGA1088 Bias Connection for High Saturated Power Mode**

*Note: Devices designated as EPU are typically early in their characterization process prior to finalizing all electrical and process specifications. Specifications are subject to change without notice.*

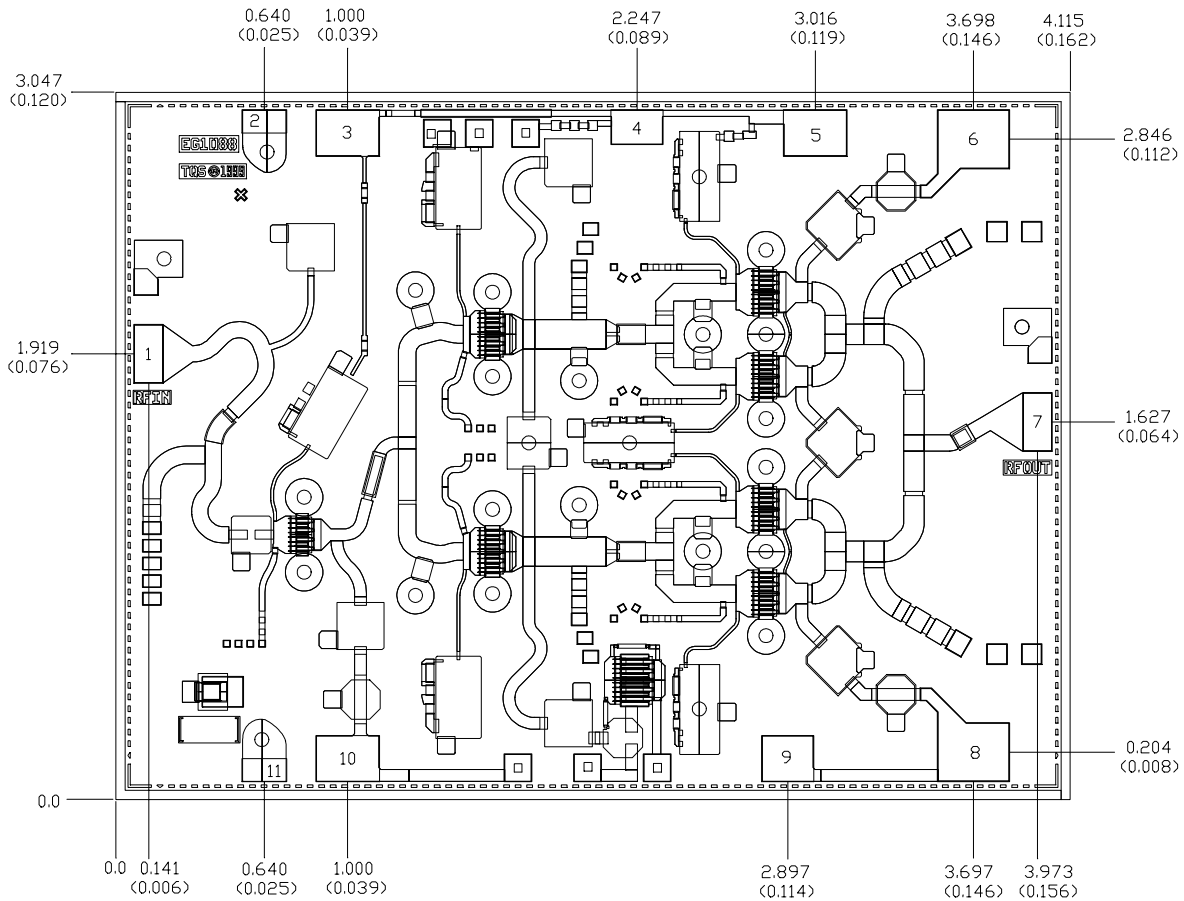

Units: millimeters (inches)

Thickness: 0.1016 (0.004)

Chip edge to bond pad dimensions are shown to center of bond pad

Chip size tolerance: +/- 0.051 (0.002)

Bond Pad #1 (RF Input)	0.120 x 0.249 (0.005 x 0.010)
Bond Pad #2 (GND)	0.190 x 0.100 (0.008 x 0.004)
Bond Pad #3 (Vg1)	0.270 x 0.195 (0.011 x 0.008)
Bond Pad #4 (Vg2)	0.220 x 0.144 (0.009 x 0.006)
Bond Pad #5 (Vg3)	0.270 x 0.195 (0.011 x 0.008)
Bond Pad #6, #8 (Vd3)	0.306 x 0.250 (0.012 x 0.010)
Bond Pad #7 (RF Output)	0.120 x 0.249 (0.005 x 0.010)
Bond Pad #9 (Vd2)	0.220 x 0.195 (0.009 x 0.008)
Bond Pad #10 (Vd1)	0.270 x 0.195 (0.011 x 0.008)
Bond Pad #11 (GND)	0.190 x 0.100 (0.008 x 0.004)

*Note: Devices designated as EPU are typically early in their characterization process prior to finalizing all electrical and process specifications. Specifications are subject to change without notice.*