

- **Meets or Exceeds the Requirements of ANSI TIA/EIA-232-F and ITU V.28**
- **Designed to Support Data Rates up to 120 kbit/s Over 3-m Cable**
- **ESD Protection Exceeds 5 kV on All Pins**
- **Flow-Through Design**
- **Wide-Driver Supply Voltage . . . ± 7.5 V to ± 15 V**
- **Functionally Interchangeable With Motorola MC145406 and Texas Instruments SN75C1406**

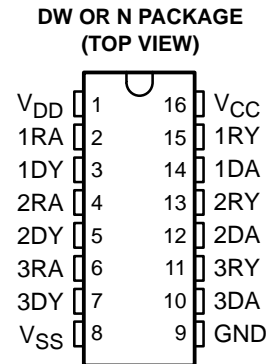

description

The TL145406 is a bipolar device containing three independent drivers and receivers that are used to interface data terminal equipment (DTE) with data circuit-terminating equipment (DCE). The drivers and receivers of the TL145406 are similar to those of the SN75188 quadruple driver and SN75189A quadruple receiver, respectively. The pinout matches the flow-through design of the SN75C1406 to reduce the board space required and to allow easy interconnection. The bipolar circuits and processing of the TL145406 provide a rugged low-cost solution for this function at the expense of quiescent power and external passive components relative to the SN75C1406.

The TL145406 complies with the requirements of TIA/EIA-232-F and ITU (formerly CCITT) V.28 standards. These standards are for data interchange between a host computer and peripheral at signaling rates up to 20 kbit/s. The switching speeds of the TL145406 are fast enough to support rates up to 120 kbit/s with lower capacitive loads (shorter cables). Interoperability at the higher signaling rates cannot be assured unless the designer has design control of the cable and of the interface circuits at both ends. For interoperability at signaling rates to 120 kbit/s, use of TIA/EIA-423-B (ITU V.10) and TIA/EIA-422-B (ITU V.11) standards is recommended.

The TL145406 is characterized for operation from 0°C to 70°C.

AVAILABLE OPTIONS

T _A	PACKAGED DEVICES	
	PLASTIC DIP (N)	PLASTIC SMALL OUTLINE (DW)
0°C to 70°C	TL145406N	TL145406DW

The DW package also is available taped and reeled. Add the suffix R to the device type (e.g., TL145406DWR).



Please be aware that an important notice concerning availability, standard warranty, and use in critical applications of Texas Instruments semiconductor products and disclaimers thereto appears at the end of this data sheet.

PRODUCTION DATA information is current as of publication date. Products conform to specifications per the terms of Texas Instruments standard warranty. Production processing does not necessarily include testing of all parameters.



TL145406 TRIPLE RS-232 DRIVERS/RECEIVERS

SLLS185D – DECEMBER 1994 – REVISED JULY 2001

logic symbol†

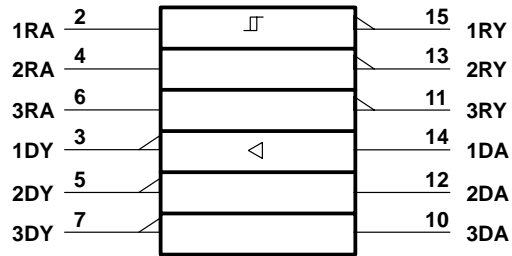

† This symbol is in accordance with ANSI/IEEE Std 91-1984 and IEC Publication 617-12.

logic diagram (positive logic)

Typical of Each Receiver

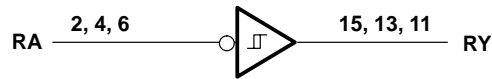

Typical of Each Driver

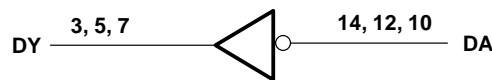

schematic (each driver)

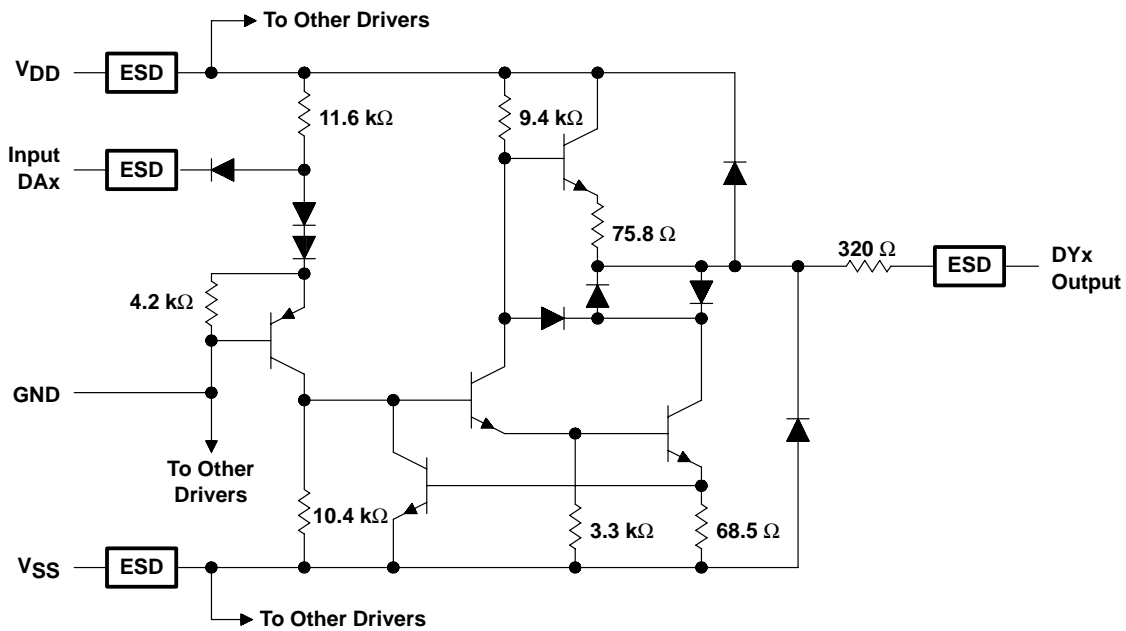

Resistor values shown are nominal.

schematic (each receiver)

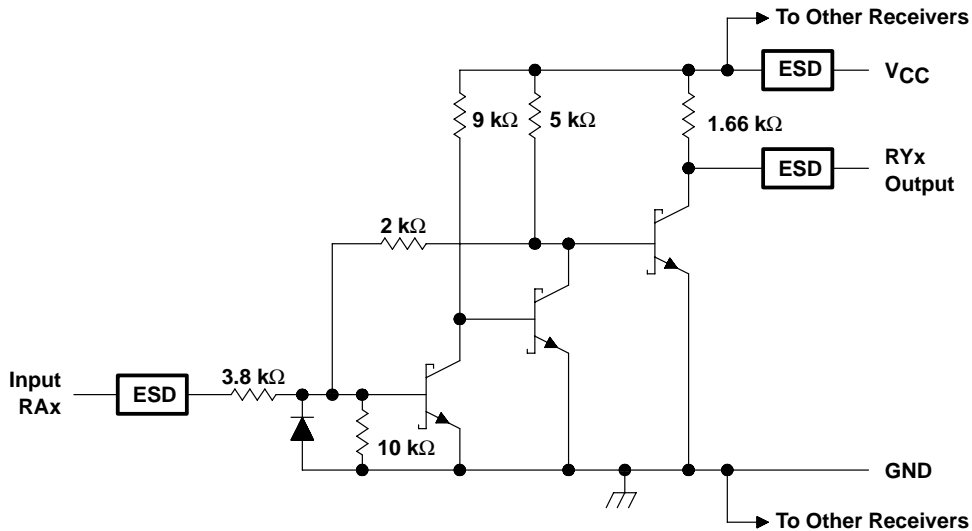

Resistor values shown are nominal.

absolute maximum ratings over operating free-air temperature range (unless otherwise noted)†

Supply voltage (see Note 1): V_{CC}	10 V
V_{DD}	15 V
V_{SS}	-15 V
Input voltage range: Driver	-15 V to 7 V
Receiver	-30 V to 30 V
Driver output voltage range	-15 V to 15 V
Receiver low-level output current	20 mA
Package thermal impedance, θ_{JA} (see Note 2): DW package	57°C/W
N package	67°C/W
Lead temperature 1,6 mm (1/16 inch) from case for 10 seconds	260°C
Storage temperature range, T_{stg}	-65°C to 150°C

† Stresses beyond those listed under "absolute maximum ratings" may cause permanent damage to the device. These are stress ratings only, and functional operation of the device at these or any other conditions beyond those indicated under "recommended operating conditions" is not implied. Exposure to absolute-maximum-rated conditions for extended periods may affect device reliability.

- NOTES: 1. All voltages are with respect to the network ground terminal.
2. The package thermal impedance is calculated in accordance with JESD 51-7.

TL145406

TRIPLE RS-232 DRIVERS/RECEIVERS

SLLS185D – DECEMBER 1994 – REVISED JULY 2001

recommended operating conditions

		MIN	NOM	MAX	UNIT
V _{DD}	Supply voltage	7.5	9	15	V
V _{SS}	Supply voltage	-7.5	-9	-15	V
V _{CC}	Supply voltage	4.5	5	5.5	V
V _{IH}	High-level input voltage (driver only)	1.9			V
V _{IL}	Low-level input voltage (driver only)			0.8	V
I _{OH}	High-level output current	Driver		-6	mA
		Receiver		-0.5	
I _{OL}	Low-level output current	Driver		6	mA
		Receiver		16	
T _A	Operating free-air temperature	0		70	°C

supply currents

PARAMETER	TEST CONDITIONS		MIN	TYP	MAX	UNIT
I _{DD}	All inputs at 1.9 V, No load	V _{DD} = 9 V, V _{SS} = -9 V			15	mA
		V _{DD} = 12 V, V _{SS} = -12 V			19	
		V _{DD} = 15 V, V _{SS} = -15 V			25	
	All inputs at 0.8 V, No load	V _{DD} = 9 V, V _{SS} = -9 V			4.5	
		V _{DD} = 12 V, V _{SS} = -12 V			5.5	
		V _{DD} = 15 V, V _{SS} = -15 V			9	
I _{SS}	All inputs at 1.9 V, No load	V _{DD} = 9 V, V _{SS} = -9 V			-15	mA
		V _{DD} = 12 V, V _{SS} = -12 V			-19	
		V _{DD} = 15 V, V _{SS} = -15 V			-25	
	All inputs at 0.8 V, No load	V _{DD} = 9 V, V _{SS} = -9 V			-3.2	
		V _{DD} = 12 V, V _{SS} = -12 V			-3.2	
		V _{DD} = 15 V, V _{SS} = -15 V			-3.2	
I _{CC}	All inputs at 5 V, No load,	V _{CC} = 5 V		13.2	20	mA



DRIVER SECTION

electrical characteristics over recommended operating free-air temperature range, $V_{DD} = 9\text{ V}$, $V_{SS} = -9\text{ V}$, $V_{CC} = 5\text{ V}$ (unless otherwise noted)

PARAMETER		TEST CONDITIONS			MIN	TYP	MAX	UNIT
V_{OH}	High-level output voltage	$V_{IL} = 0.8\text{ V}$,	$R_L = 3\text{ k}\Omega$,	See Figure 1	6	7.5		V
V_{OL}	Low-level output voltage (see Note 3)	$V_{IH} = 1.9\text{ V}$,	$R_L = 3\text{ k}\Omega$,	See Figure 1		-7.5	-6	V
I_{IH}	High-level input current	$V_I = 5\text{ V}$,	See Figure 2				10	μA
I_{IL}	Low-level input current	$V_I = 0$,	See Figure 2				-1.6	mA
$I_{OS(H)}$	High-level short-circuit output current (see Note 4)	$V_{IL} = 0.8\text{ V}$,	$V_O = 0$ or V_{SS} ,	See Figure 1	-4.5	-10	-19.5	mA
$I_{OS(L)}$	Low-level short-circuit output current	$V_{IH} = 2\text{ V}$,	$V_O = 0$ or V_{DD} ,	See Figure 1	4.5	10	19.5	mA
r_O	Output resistance (see Note 5)	$V_{CC} = V_{DD} = V_{SS} = 0$, $V_O = -2\text{ V}$ to 2 V			300			Ω

- NOTES: 3. The algebraic convention, where the more positive (less negative) limit is designated as maximum, is used in this data sheet for logic levels only (e.g., if -10 V is maximum, the typical value is a more negative voltage).
 4. Output short-circuit conditions must maintain the total power dissipation below absolute maximum ratings.
 5. Test conditions are those specified by TIA/EIA-232-F and as listed above.

switching characteristics, $V_{CC} = 5\text{ V}$, $V_{DD} = 12\text{ V}$, $V_{SS} = -12\text{ V}$, $T_A = 25^\circ\text{C}$

PARAMETER		TEST CONDITIONS			MIN	TYP	MAX	UNIT
t_{PLH}	Propagation delay time, low- to high-level output	$R_L = 3\text{ k}\Omega$ to $7\text{ k}\Omega$, $C_L = 15\text{ pF}$, See Figure 3				315	500	ns
t_{PHL}	Propagation delay time, high- to low-level output	$R_L = 3\text{ k}\Omega$ to $7\text{ k}\Omega$, $C_L = 15\text{ pF}$, See Figure 3				75	175	ns
t_{TLH}	Transition time, low- to high-level output	$R_L = 3\text{ k}\Omega$ to $7\text{ k}\Omega$, $C_L = 15\text{ pF}$, See Figure 3				60	100	ns
		$R_L = 3\text{ k}\Omega$ to $7\text{ k}\Omega$, $C_L = 2500\text{ pF}$, See Figure 3 and Note 6				1.7	2.5	μs
t_{THL}	Transition time, high- to low-level output	$R_L = 3\text{ k}\Omega$ to $7\text{ k}\Omega$, $C_L = 15\text{ pF}$, See Figure 3				40	75	ns
		$R_L = 3\text{ k}\Omega$ to $7\text{ k}\Omega$, $C_L = 2500\text{ pF}$, See Figure 3 and Note 7				1.5	2.5	μs

- NOTES: 6. Measured between -3 V and 3 V points of the output waveform (TIA/EIA-232-F conditions). All unused inputs are tied.
 7. Measured between 3 V and -3 V points of the output waveform (TIA/EIA-232-F conditions). All unused inputs are tied.

RECEIVER SECTION

electrical characteristics over recommended operating conditions (unless otherwise noted)

PARAMETER		TEST CONDITIONS	MIN	TYP†	MAX	UNIT	
V _{IT+}	Positive-going threshold voltage	See Figure 5	T _A = 25°C	1.75	1.9	2.3	V
			T _A = 0°C to 70°C	1.55		2.3	
V _{IT-}	Negative-going threshold voltage		0.75	0.97	1.25	V	
V _{hys}	Input hysteresis (V _{IT+} - V _{IT-})		0.5			V	
V _{OH}	High-level output voltage	I _{OH} = -0.5 mA	V _I = 0.75 V	2.6	4	5	V
			Inputs open	2.6			
V _{OL}	Low-level output voltage	I _{OL} = 10 mA, V _I = 3 V		0.2	0.45	V	
I _{IH}	High-level input current	V _I = 25 V, See Figure 5		3.6	8.3	mA	
		V _I = 3 V, See Figure 5		0.43			
I _{IL}	Low-level input current	V _I = -25 V, See Figure 5		-3.6	-8.3	mA	
		V _I = -3 V, See Figure 5		-0.43			
I _{OS}	Short-circuit output current			-3.4	-12	mA	

† All typical values are at T_A = 25°C, V_{CC} = 5, V_{DD} = 9 V, and V_{SS} = -9 V.

switching characteristics, V_{CC} = 5 V, V_{DD} = 12 V, V_{SS} = -12 V, T_A = 25°C

PARAMETER	TEST CONDITIONS	MIN	TYP	MAX	UNIT
t _{PLH}	Propagation delay time, low- to high-level output C _L = 50 pF, R _L = 5 kΩ, See Figure 6		107	425	ns
t _{PHL}	Propagation delay time, high- to low-level output C _L = 50 pF, R _L = 5 kΩ, See Figure 6		42	150	ns
t _{TLH}	Transition time, low- to high-level output C _L = 50 pF, R _L = 5 kΩ, See Figure 6		175	400	ns
t _{THL}	Transition time, high- to low-level output C _L = 50 pF, R _L = 5 kΩ, See Figure 6		16	60	ns

PARAMETER MEASUREMENT INFORMATION

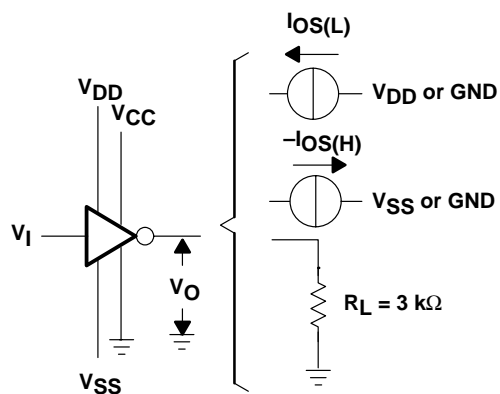

Figure 1. Driver Test Circuit for V_{OH}, V_{OL}, I_{OS(H)}, and I_{OS(L)}

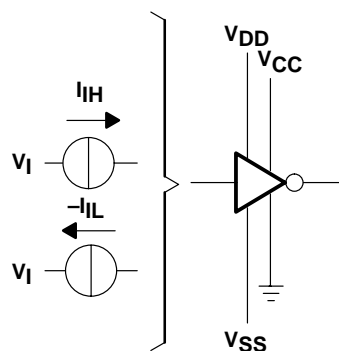
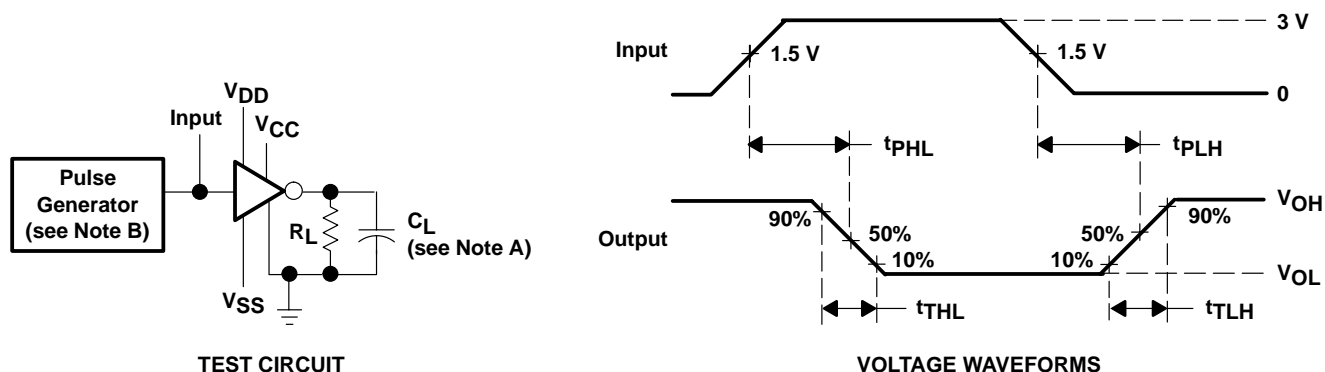

Figure 2. Driver Test Circuit for I_{IH} and I_{IL}

PARAMETER MEASUREMENT INFORMATION



NOTES: A. C_L includes probe and jig capacitance.
B. The pulse generator has the following characteristics: $t_w = 25 \mu s$, $PRR = 20 \text{ kHz}$, $Z_O = 50 \Omega$, $t_r = t_f < 50 \text{ ns}$.

Figure 3. Driver Test Circuit and Voltage Waveforms

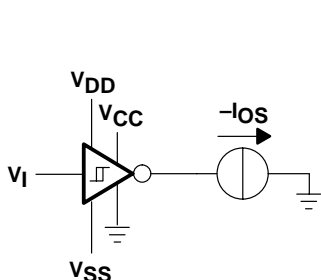

Figure 4. Receiver Test Circuit for I_{OS}

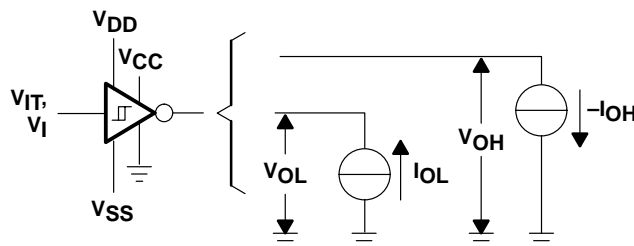
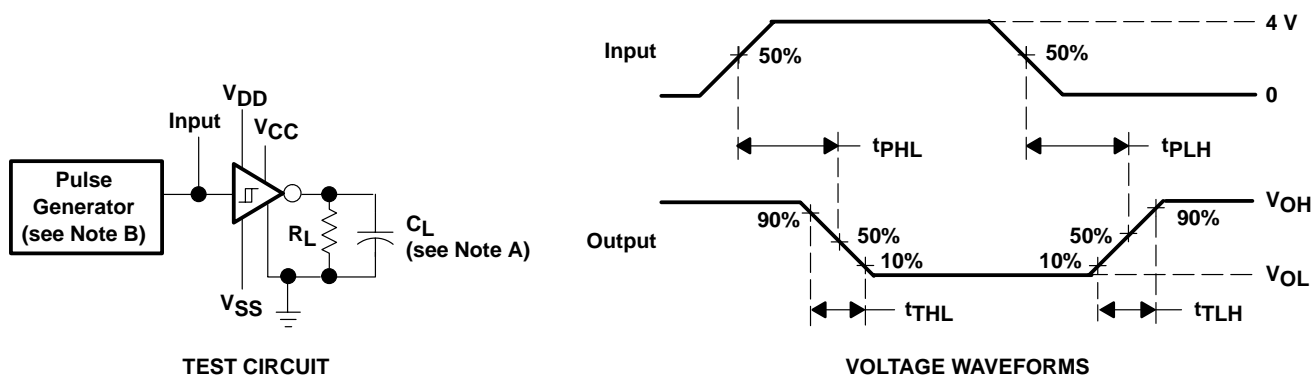

Figure 5. Receiver Test Circuit for V_{IT} , V_{OH} , and V_{OL}



NOTES: A. C_L includes probe and jig capacitance.
B. The pulse generator has the following characteristics: $t_w = 25 \mu s$, $PRR = 20 \text{ kHz}$, $Z_O = 50 \Omega$, $t_r = t_f < 50 \text{ ns}$.

Figure 6. Receiver Propagation and Transition Times

TYPICAL CHARACTERISTICS

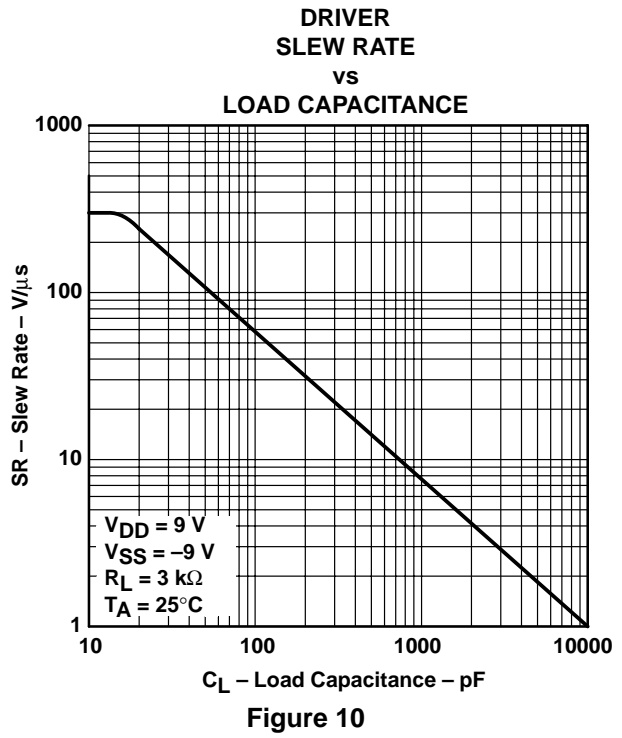
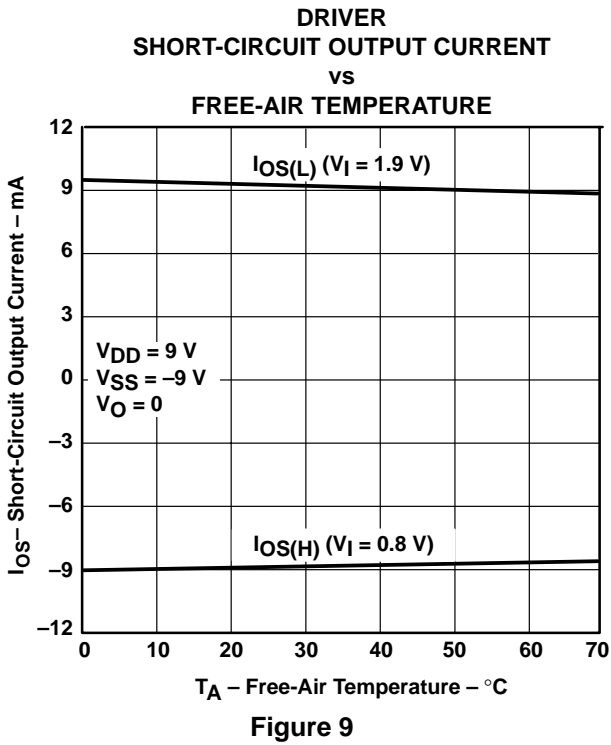
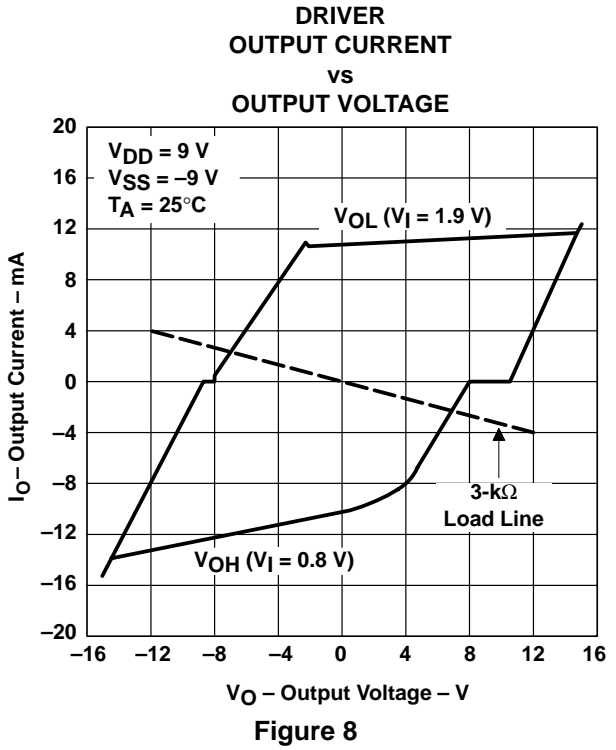
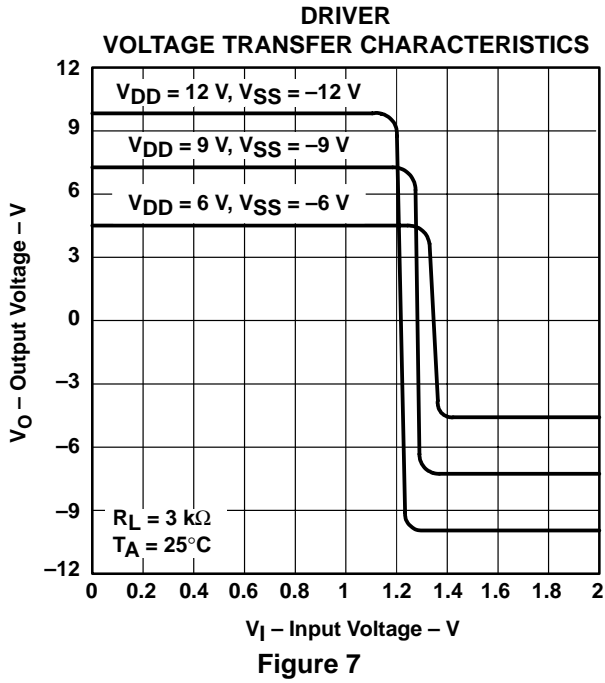

TYPICAL CHARACTERISTICS

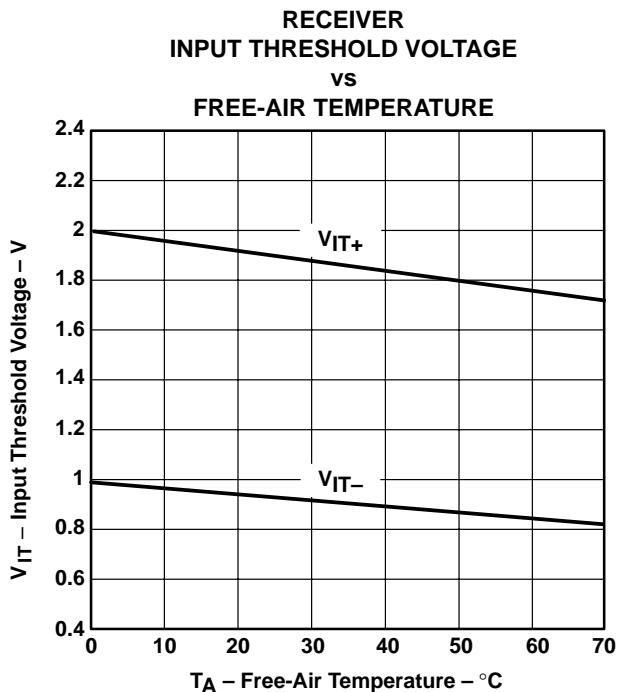

Figure 11

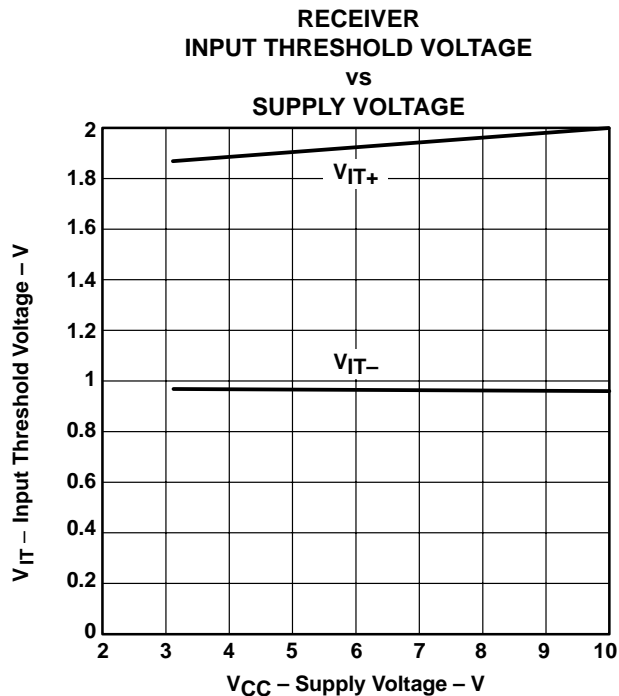
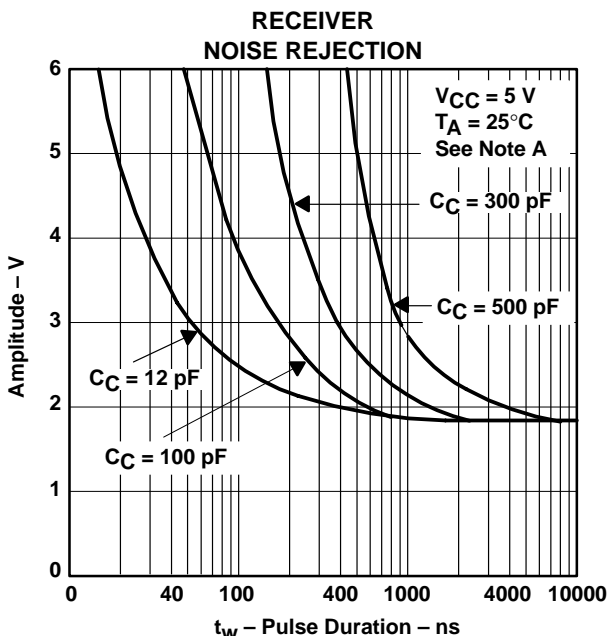

Figure 12



NOTE A: This figure shows the maximum amplitude of a positive-going pulse that, starting from 0, does not cause a change of the output level.

Figure 13

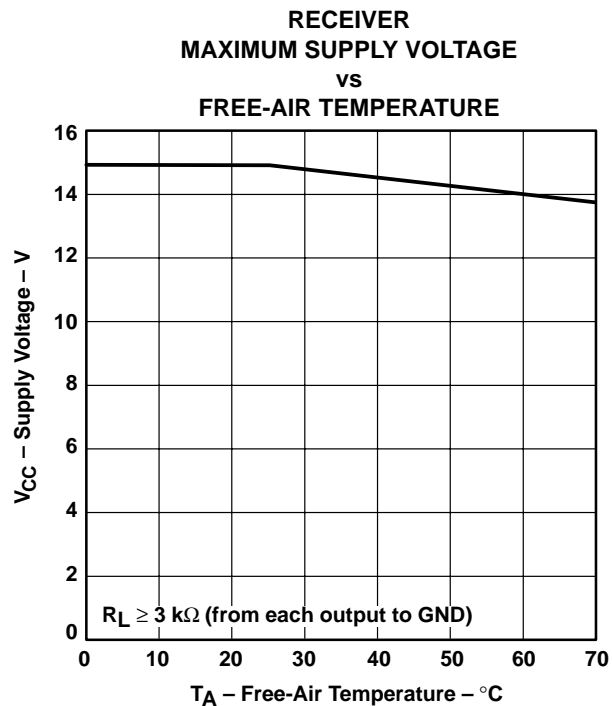

Figure 14

TL145406 TRIPLE RS-232 DRIVERS/RECEIVERS

SLLS185D – DECEMBER 1994 – REVISED JULY 2001

APPLICATION INFORMATION

Diodes placed in series with the V_{DD} and V_{SS} leads protect the TL145406 during the fault condition in which the device outputs are shorted to ± 15 V and the power supplies are at low. Diodes also provide low-impedance paths to ground (see Figure 15).

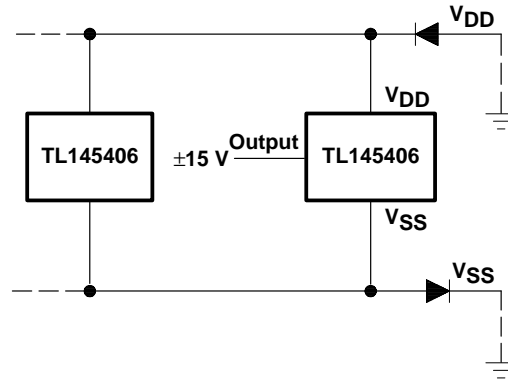

Figure 15. Power-Supply Protection to Meet Power-Off Fault Conditions of ANSI TIA/EIA-232-F

PACKAGING INFORMATION

Orderable Device	Status ⁽¹⁾	Package Type	Package Drawing	Pins	Package Qty	Eco Plan ⁽²⁾	Lead/Ball Finish	MSL Peak Temp ⁽³⁾
TL145406DW	ACTIVE	SOIC	DW	16	40	Green (RoHS & no Sb/Br)	CU NIPDAU	Level-1-260C-UNLIM
TL145406DWE4	ACTIVE	SOIC	DW	16	40	Green (RoHS & no Sb/Br)	CU NIPDAU	Level-1-260C-UNLIM
TL145406DWR	ACTIVE	SOIC	DW	16	2000	Green (RoHS & no Sb/Br)	CU NIPDAU	Level-1-260C-UNLIM
TL145406DWRE4	ACTIVE	SOIC	DW	16	2000	Green (RoHS & no Sb/Br)	CU NIPDAU	Level-1-260C-UNLIM
TL145406N	ACTIVE	PDIP	N	16	25	Pb-Free (RoHS)	CU NIPDAU	N / A for Pkg Type
TL145406NE4	ACTIVE	PDIP	N	16	25	Pb-Free (RoHS)	CU NIPDAU	N / A for Pkg Type

⁽¹⁾ The marketing status values are defined as follows:

ACTIVE: Product device recommended for new designs.

LIFEBUY: TI has announced that the device will be discontinued, and a lifetime-buy period is in effect.

NRND: Not recommended for new designs. Device is in production to support existing customers, but TI does not recommend using this part in a new design.

PREVIEW: Device has been announced but is not in production. Samples may or may not be available.

OBSOLETE: TI has discontinued the production of the device.

⁽²⁾ Eco Plan - The planned eco-friendly classification: Pb-Free (RoHS), Pb-Free (RoHS Exempt), or Green (RoHS & no Sb/Br) - please check <http://www.ti.com/productcontent> for the latest availability information and additional product content details.

TBD: The Pb-Free/Green conversion plan has not been defined.

Pb-Free (RoHS): TI's terms "Lead-Free" or "Pb-Free" mean semiconductor products that are compatible with the current RoHS requirements for all 6 substances, including the requirement that lead not exceed 0.1% by weight in homogeneous materials. Where designed to be soldered at high temperatures, TI Pb-Free products are suitable for use in specified lead-free processes.

Pb-Free (RoHS Exempt): This component has a RoHS exemption for either 1) lead-based flip-chip solder bumps used between the die and package, or 2) lead-based die adhesive used between the die and leadframe. The component is otherwise considered Pb-Free (RoHS compatible) as defined above.

Green (RoHS & no Sb/Br): TI defines "Green" to mean Pb-Free (RoHS compatible), and free of Bromine (Br) and Antimony (Sb) based flame retardants (Br or Sb do not exceed 0.1% by weight in homogeneous material)

⁽³⁾ MSL, Peak Temp. -- The Moisture Sensitivity Level rating according to the JEDEC industry standard classifications, and peak solder temperature.

Important Information and Disclaimer:The information provided on this page represents TI's knowledge and belief as of the date that it is provided. TI bases its knowledge and belief on information provided by third parties, and makes no representation or warranty as to the accuracy of such information. Efforts are underway to better integrate information from third parties. TI has taken and continues to take reasonable steps to provide representative and accurate information but may not have conducted destructive testing or chemical analysis on incoming materials and chemicals. TI and TI suppliers consider certain information to be proprietary, and thus CAS numbers and other limited information may not be available for release.

In no event shall TI's liability arising out of such information exceed the total purchase price of the TI part(s) at issue in this document sold by TI to Customer on an annual basis.

N (R-PDIP-T**)

PLASTIC DUAL-IN-LINE PACKAGE

16 PINS SHOWN



- NOTES:
- A. All linear dimensions are in inches (millimeters).
 - B. This drawing is subject to change without notice.
 - $\triangle C$ Falls within JEDEC MS-001, except 18 and 20 pin minimum body length (Dim A).
 - $\triangle D$ The 20 pin end lead shoulder width is a vendor option, either half or full width.

4040049/E 12/2002

DW (R-PDSO-G16)

PLASTIC SMALL-OUTLINE PACKAGE

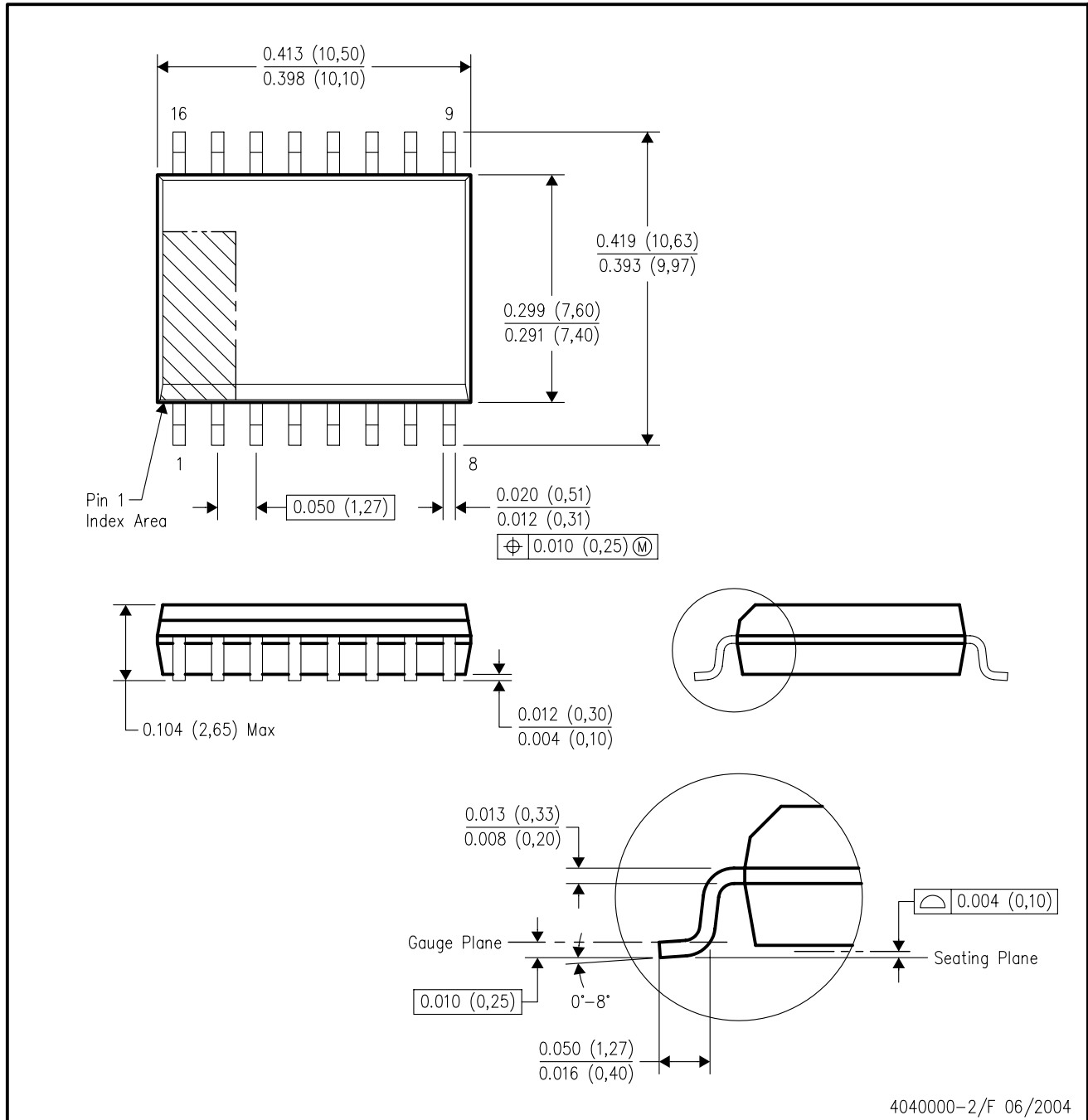

4040000-2/F 06/2004

- NOTES:
- A. All linear dimensions are in inches (millimeters).
 - B. This drawing is subject to change without notice.
 - C. Body dimensions do not include mold flash or protrusion not to exceed 0.006 (0,15).
 - D. Falls within JEDEC MS-013 variation AA.

IMPORTANT NOTICE

Texas Instruments Incorporated and its subsidiaries (TI) reserve the right to make corrections, modifications, enhancements, improvements, and other changes to its products and services at any time and to discontinue any product or service without notice. Customers should obtain the latest relevant information before placing orders and should verify that such information is current and complete. All products are sold subject to TI's terms and conditions of sale supplied at the time of order acknowledgment.

TI warrants performance of its hardware products to the specifications applicable at the time of sale in accordance with TI's standard warranty. Testing and other quality control techniques are used to the extent TI deems necessary to support this warranty. Except where mandated by government requirements, testing of all parameters of each product is not necessarily performed.

TI assumes no liability for applications assistance or customer product design. Customers are responsible for their products and applications using TI components. To minimize the risks associated with customer products and applications, customers should provide adequate design and operating safeguards.

TI does not warrant or represent that any license, either express or implied, is granted under any TI patent right, copyright, mask work right, or other TI intellectual property right relating to any combination, machine, or process in which TI products or services are used. Information published by TI regarding third-party products or services does not constitute a license from TI to use such products or services or a warranty or endorsement thereof. Use of such information may require a license from a third party under the patents or other intellectual property of the third party, or a license from TI under the patents or other intellectual property of TI.

Reproduction of information in TI data books or data sheets is permissible only if reproduction is without alteration and is accompanied by all associated warranties, conditions, limitations, and notices. Reproduction of this information with alteration is an unfair and deceptive business practice. TI is not responsible or liable for such altered documentation.

Resale of TI products or services with statements different from or beyond the parameters stated by TI for that product or service voids all express and any implied warranties for the associated TI product or service and is an unfair and deceptive business practice. TI is not responsible or liable for any such statements.

Following are URLs where you can obtain information on other Texas Instruments products and application solutions:

Products		Applications	
Amplifiers	amplifier.ti.com	Audio	www.ti.com/audio
Data Converters	dataconverter.ti.com	Automotive	www.ti.com/automotive
DSP	dsp.ti.com	Broadband	www.ti.com/broadband
Interface	interface.ti.com	Digital Control	www.ti.com/digitalcontrol
Logic	logic.ti.com	Military	www.ti.com/military
Power Mgmt	power.ti.com	Optical Networking	www.ti.com/opticalnetwork
Microcontrollers	microcontroller.ti.com	Security	www.ti.com/security
		Telephony	www.ti.com/telephony
		Video & Imaging	www.ti.com/video
		Wireless	www.ti.com/wireless

Mailing Address: Texas Instruments
Post Office Box 655303 Dallas, Texas 75265

Copyright © 2006, Texas Instruments Incorporated