

Low Dropout, Two-Bank LED Driver with PWM Brightness Control

FEATURES

- Regulated Output Current with 2% LED-to-LED Matching
- Drives up to Four LEDs at 25mA Each in a Common Cathode Topology
- 28mV Typical Dropout Voltage Extends Usable Supply Range in Li-Ion Battery Applications
- Brightness Control Using PWM Signals
- Two 2-LED Banks with Independent Enable and PWM Brightness Control per Bank
- No Internal Switching Signals—Eliminates EMI
- Default LED Current Eliminates External Components
 - Default values from 3mA to 10mA (in 1mA increments) available using innovative factory EEPROM programming
 - Optional external resistor can be used for high-accuracy, user-programmable current
- Over-Current and Over-Temperature Protection
- Available in Wafer Chip-Scale Package

APPLICATIONS

- Keypad and Display Backlighting
- White and Color LEDs
- Cellular Handsets
- PDAs and Smartphones

**TPS7510x YFF
9-Ball WCSP
(Top View)**



DESCRIPTION

The TPS7510x linear low dropout (LDO) matching LED current source is optimized for low power keypad and navigation pad LED backlighting applications. The device provides a constant current to up to four unmatched LEDs organized in two banks of two LEDs each in a common-cathode topology. Without an external resistor, the current source defaults to factory-programmable, preset current level with $\pm 0.5\%$ accuracy (typical). An optional external resistor can be used to set initial brightness to user-programmable values with higher accuracy. Brightness can be varied from off to full brightness by inputting a pulse width modulation (PWM) signal on each Enable pin. Each bank has independent enable and brightness control, but current matching is done to all four channels concurrently. The input supply range is ideally suited for single-cell Li-Ion battery supplies and the TPS7510x can provide up to 25mA per LED.

No internal switching signals are used, eliminating troublesome electromagnetic interference (EMI). The TPS7510x is offered in an ultra-small, 9-ball, 0.4mm ball-pitch wafer chip-scale package (WCSP) and a 3mm \times 3mm QFN package, yielding a very compact total solution size ideal for mobile handsets and portable backlighting applications. The device is fully specified over $T_J = -40^\circ\text{C}$ to $+85^\circ\text{C}$.

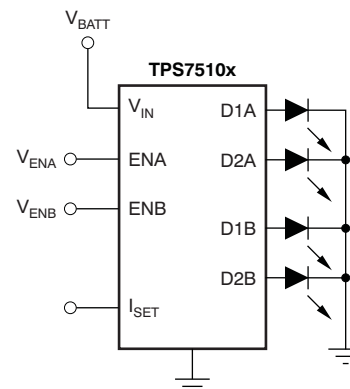

Please be aware that an important notice concerning availability, standard warranty, and use in critical applications of Texas Instruments semiconductor products and disclaimers thereto appears at the end of this data sheet.

All trademarks are the property of their respective owners.



This integrated circuit can be damaged by ESD. Texas Instruments recommends that all integrated circuits be handled with appropriate precautions. Failure to observe proper handling and installation procedures can cause damage.

ESD damage can range from subtle performance degradation to complete device failure. Precision integrated circuits may be more susceptible to damage because very small parametric changes could cause the device not to meet its published specifications.

ORDERING INFORMATION⁽¹⁾

| PRODUCT ID | OPTIONS ⁽²⁾ |
|-----------------|--|
| TPS7510x $yyyz$ | X is the nominal default diode output current (for example, 3 = 3mA, 5 = 5mA, and 0 = 10mA). YYY is the package designator. Z is the reel quantity (R = 3000, T = 250). |

- (1) For the most current package and ordering information see the Package Option Addendum at the end of this document, or see the TI web site at www.ti.com.
- (2) Default set currents from 3mA to 10mA in 1mA increments are available through the use of innovative factory EEPROM programming. Minimum order quantities may apply. Contact factory for details and availability.

ABSOLUTE MAXIMUM RATINGS

| PARAMETER | VALUE |
|---|--------------------------|
| V _{IN} range | -0.3V to +7.0V |
| V _{ISET} , V _{ENA} , V _{ENB} , V _{DX} range | -0.3V to V _{IN} |
| I _{DX} for D1A, D2A, D1B, D2B | 35mA |
| D1A, D2A, D1B, D2B short circuit duration | Indefinite |
| Continuous total power dissipation | Internally limited |
| Junction temperature (T _J) | -55°C to +150°C |
| Storage temperature | -55°C to +150°C |

DISSIPATION RATINGS

| BOARD | PACKAGE | R _{θJC} | R _{θJA} | DERATING FACTOR | T _A < +25°C | T _A = +70°C | T _A = +85°C |
|-----------------------|---------|------------------|------------------|---------------------------------|------------------------|------------------------|------------------------|
| | | | | ABOVE T _A = +25°C | | | |
| Low-K ⁽¹⁾ | YFF | 55°C/W | 208°C/W | 4.8mW/°C | 480mW | 264mW | 192mW |
| High-K ⁽²⁾ | YFF | 55°C/W | 142°C/W | 7.0mW/°C | 704mW | 387mW | 282mW |

- (1) The JEDEC low-K (1s) board used to derive this data was a 3 inch × 3 inch, two-layer board with 2 ounce copper traces on top of the board.
- (2) The JEDEC high-K (2s2p) board used to derive this data was a 3 inch × 3 inch, multi-layer board with 1 ounce internal power and ground planes and 2 ounce copper traces on top and bottom of the board.

RECOMMENDED OPERATING CONDITIONS

| PARAMETER | MIN | TYP | MAX | UNIT |
|---|-----|-----|-----|------|
| V _{IN} Input voltage | 2.7 | | 5.5 | V |
| I _{DX} Operating current per LED | 3 | | 25 | mA |
| t _{PWM} On-time for PWM signal | 33 | | | μs |
| T _J Operating junction temperature range | -40 | | +85 | °C |

ELECTRICAL CHARACTERISTICS

Over operating junction temperature range ($T_J = -40^{\circ}\text{C}$ to $+85^{\circ}\text{C}$), $V_{IN} = 3.8\text{V}$, DxA and $DxB = 3.3\text{V}$, $R_{SET} = 32.4\text{k}\Omega$, and ENA and $ENB = 3.8\text{V}$, unless otherwise noted. Typical values are at $T_A = +25^{\circ}\text{C}$.

| PARAMETER | | TEST CONDITIONS | MIN | TYP | MAX | UNIT |
|---------------------------------|--|---|-------|-------|-------|--------------------|
| I_{SHDN} | Shutdown supply current | $V_{ENA,B} = 0\text{V}$, $V_{DX} = 0\text{V}$ | | 0.03 | 1.0 | μA |
| I_Q | Ground current | $I_{SET} = \text{open}$, $I_{DX} = 5\text{mA}$, $V_{IN} = 4.5\text{V}$ | | 170 | 200 | μA |
| ΔI_D | Current matching ($I_{DXMAX} - I_{DXMIN}/I_{DXMAX}$) $\times 100\%$ | $T_A = +25^{\circ}\text{C}$ | 0 | 2 | 4 | % |
| | | $T_A = -40^{\circ}\text{C}$ to $+85^{\circ}\text{C}$ | | | 5 | |
| $\Delta I_{DX}\%/\Delta V_{IN}$ | Line regulation | $3.5\text{V} \leq V_{IN} \leq 4.5\text{V}$, $I_{DX} = 5\text{mA}$ | | 2.0 | | $\%/V$ |
| $\Delta I_{DX}\%/\Delta V_{DX}$ | Load regulation | $1.8\text{V} \leq V_{DX} \leq 3.5\text{V}$, $I_{DX} = 5\text{mA}$ | | 0.8 | | $\%/V$ |
| V_{DO} | Dropout voltage of any DX current source (V_{DX} at $I_{DX} = 0.8 \times I_{DX, nom}$) | $I_{DXnom} = 5\text{mA}$ | | 28 | 100 | mV |
| | | $I_{DXnom} = 15\text{mA}$ | | 70 | | |
| V_{ISET} | Reference voltage for current set | | 1.183 | 1.225 | 1.257 | V |
| I_{OPEN} | Diode current accuracy ⁽¹⁾ | $I_{SET} = \text{open}$, $V_{DX} = V_{IN} - 0.2\text{V}$ | | 0.5 | 3 | % |
| I_{SET} | I_{SET} pin current range | | 2.5 | | 62.5 | μA |
| k | I_{SET} to I_{DX} current ratio ⁽¹⁾ | | 400 | 420 | 435 | |
| V_{IH} | Enable high level input voltage | | 1.2 | | | V |
| V_{IL} | Enable low level input voltage | | | | 0.4 | V |
| I_{INA} | Enable pin A (V_{ENA}) input current | $V_{ENA} = 3.8\text{V}$ | | 5.0 | 6.1 | μA |
| | | $V_{ENA} = 1.8\text{V}$ | | 2.2 | | |
| I_{INB} | Enable pin B (V_{ENB}) input current | $V_{ENB} = 3.8\text{V}$ | | 4.0 | 4.9 | μA |
| | | $V_{ENB} = 1.8\text{V}$ | | 1.8 | | |
| t_{SD} | Shutdown delay time | Delay from ENA and $ENB = \text{low}$ to reach shutdown current ($I_{DX} = 0.1 \times I_{DX, nom}$) | 5 | 13 | 30 | μs |
| T_{SD} | Thermal shutdown temperature | Shutdown, temp increasing | | +165 | | $^{\circ}\text{C}$ |
| | | Reset, temp decreasing | | +140 | | |
| T_J | Operating junction temperature range | | -40 | | +85 | $^{\circ}\text{C}$ |

(1) Average of all four I_{DX} outputs.

Table 1. Recommended (1% Tolerance) Set Resistor Values

| R _{SET} (kΩ) | I _{SET} (μA) | I _{DX} (mA) ⁽¹⁾ |
|-----------------------|-----------------------|-------------------------------------|
| 511 | 2.4 | 1.0 |
| 255 | 4.8 | 2.0 |
| 169 | 7.2 | 3.0 |
| 127 | 9.6 | 4.1 |
| 102 | 12.0 | 5.0 |
| 84.5 | 14.5 | 6.1 |
| 73.2 | 16.7 | 7.0 |
| 64.9 | 18.9 | 7.9 |
| 56.2 | 21.8 | 9.2 |
| 51.1 | 24.0 | 10.1 |
| 46.4 | 26.4 | 11.1 |
| 42.2 | 29.0 | 12.2 |
| 39.2 | 31.3 | 13.1 |
| 36.5 | 33.6 | 14.1 |
| 34.0 | 36.0 | 15.1 |
| 32.4 | 37.8 | 15.9 |
| 30.1 | 40.7 | 17.1 |
| 28.7 | 42.7 | 17.9 |
| 26.7 | 45.9 | 19.3 |
| 25.5 | 48.0 | 20.2 |
| 24.3 | 50.4 | 21.2 |
| 23.2 | 52.8 | 22.2 |
| 22.1 | 55.4 | 23.3 |
| 21.5 | 57.0 | 23.9 |
| 20.5 | 59.8 | 25.1 |

(1) $I_{DX} = (V_{SET}/R_{SET}) \times k$.

PIN ASSIGNMENTS

TPS7510x YFF 9-Ball WCSP (Top View)

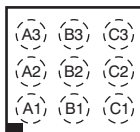

TERMINAL FUNCTIONS

| NAME | WCSP | INPUT/ OUTPUT | DESCRIPTION |
|-----------|------|------------------|--|
| ENA | A3 | I | Enable pin, Bank A. Driving this pin high turns on the current source to Bank A outputs. Driving this pin low turns off the current source to Bank A outputs. An applied PWM signal reduces the LED current (between 0mA and the maximum current set by I_{SET}) as a function of the duty cycle of the PWM signal. ENA and ENB can be tied together. ENA can be left OPEN or connected to GND if not used. See the Application Information section for more details. |
| D1A | B3 | O | Diode source current output, Bank A. Connect to LED anode. |
| D2A | C3 | O | Diode source current output, Bank A. Connect to LED anode. |
| ENB | A2 | I | Enable pin, Bank B. Driving this pin high turns on the current source to Bank B outputs. Driving this pin low turns off the current source to Bank B outputs. An applied PWM signal reduces the LED current (between 0mA and the maximum current set by I_{SET}) as a function of the duty cycle of the PWM signal. ENA and ENB can be tied together. ENB can be left OPEN or connected to GND if not used. See the Application Information section for more details. |
| V_{IN} | B2 | I | Supply Input |
| GND | C2 | — | Ground |
| I_{SET} | A1 | O | An optional resistor can be connected between this pin and GND to set the maximum current through the LEDs. If no resistor is connected, I_{SET} defaults to the internally-programmed value. |
| D1B | B1 | O | Diode source current output, Bank B. Connect to LED anode. |
| D2B | C1 | O | Diode source current output, Bank B. Connect to LED anode. |

FUNCTIONAL BLOCK DIAGRAM

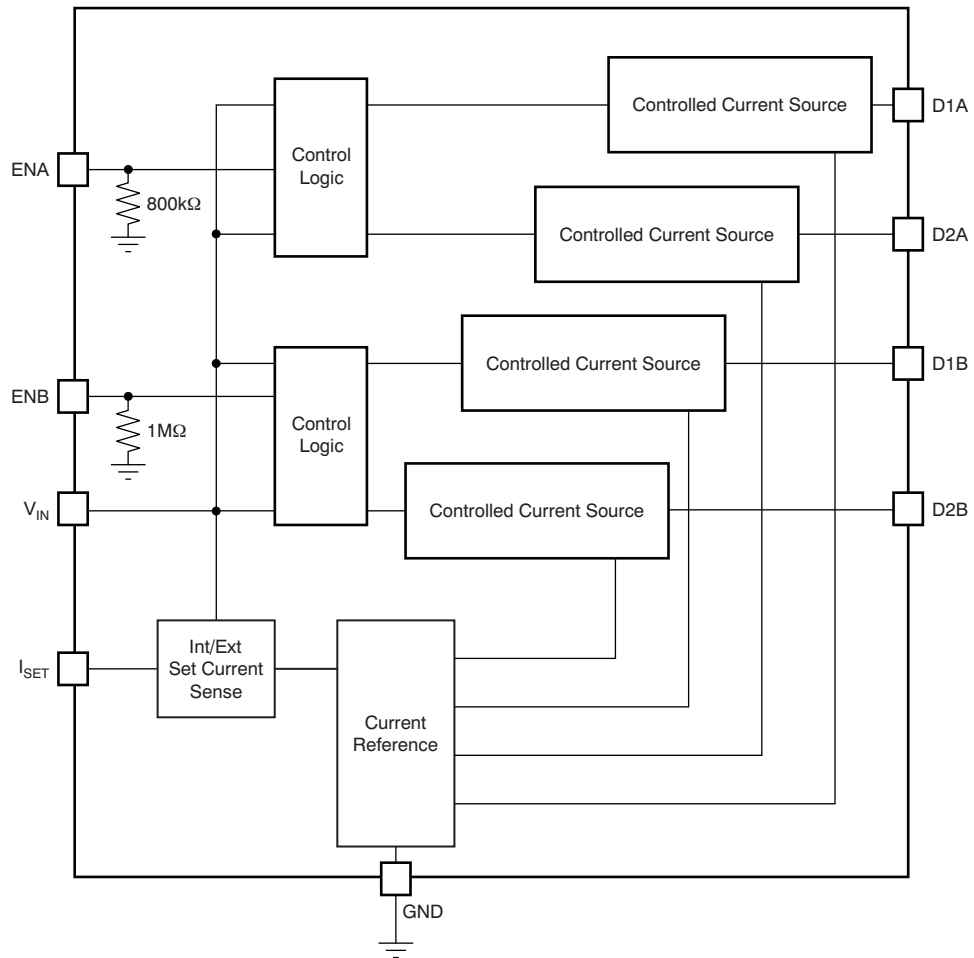

TYPICAL CHARACTERISTICS

Over operating junction temperature range ($T_J = -40^\circ\text{C}$ to $+85^\circ\text{C}$), $V_{IN} = 3.8\text{V}$, DxA and $DxB = 3.3\text{V}$, $R_{SET} = 32.4\text{k}\Omega$, and ENA and $ENB = \text{high}$, unless otherwise noted. Typical values are at $T_A = +25^\circ\text{C}$.

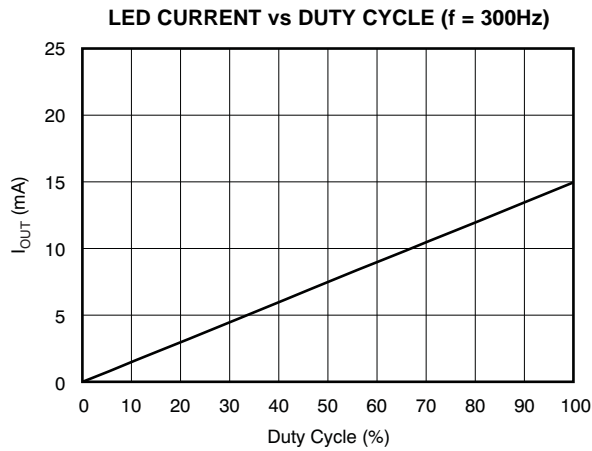

Figure 1.

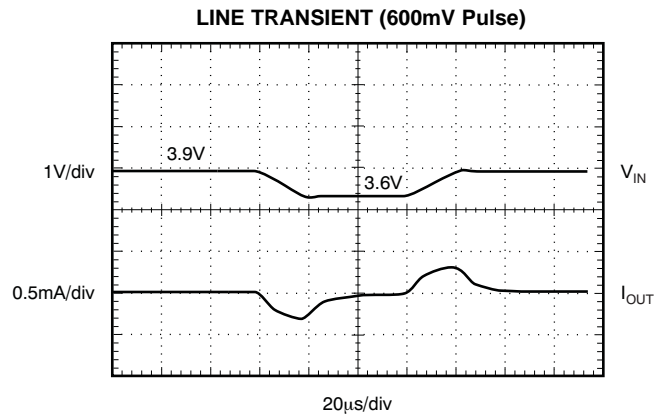

Figure 2.

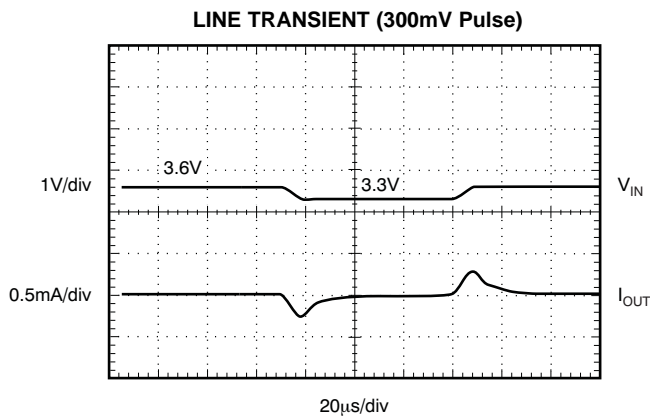

Figure 3.

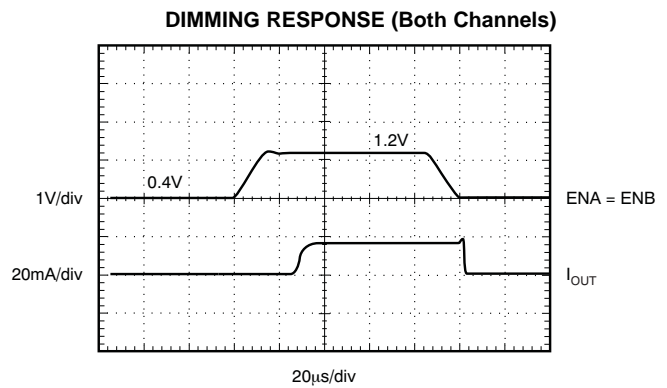

Figure 4.

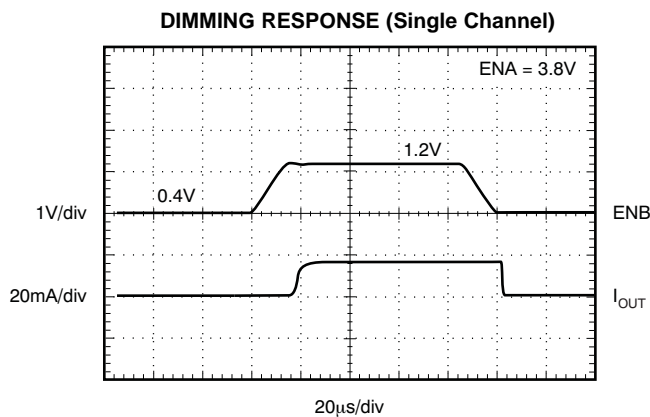

Figure 5.

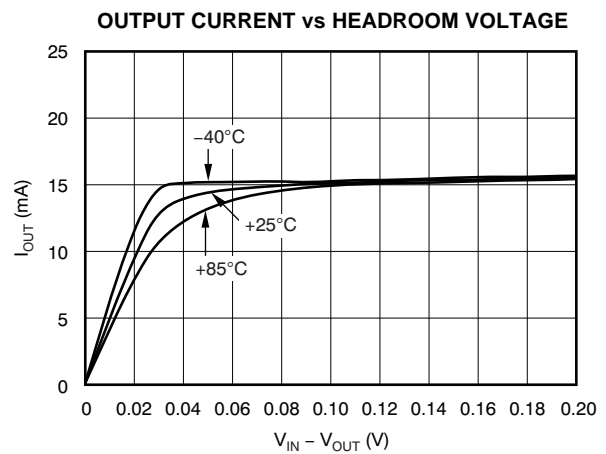

Figure 6.

TYPICAL CHARACTERISTICS (continued)

Over operating junction temperature range ($T_J = -40^{\circ}\text{C}$ to $+85^{\circ}\text{C}$), $V_{IN} = 3.8\text{V}$, DxA and $DxB = 3.3\text{V}$, $R_{SET} = 32.4\text{k}\Omega$, and ENA and $ENB = \text{high}$, unless otherwise noted. Typical values are at $T_A = +25^{\circ}\text{C}$.

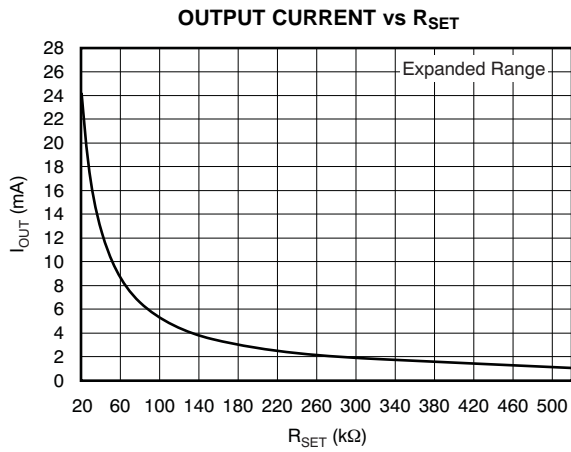

Figure 7.

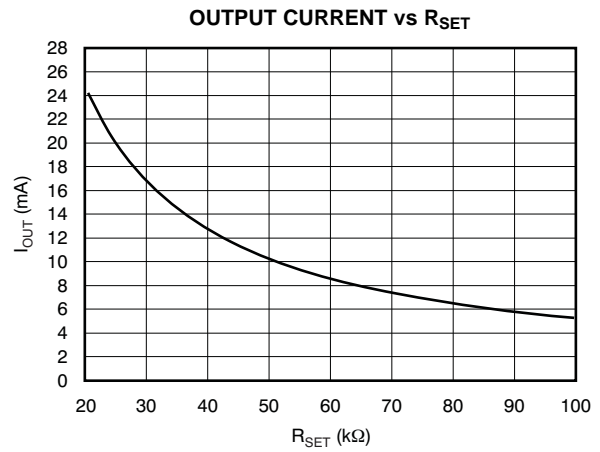

Figure 8.

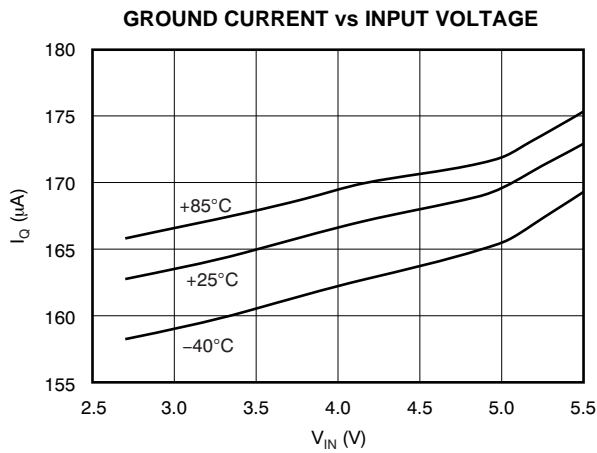

Figure 9.

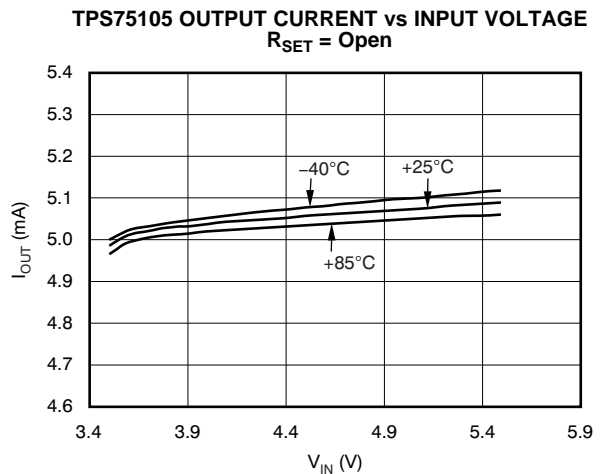

Figure 10.

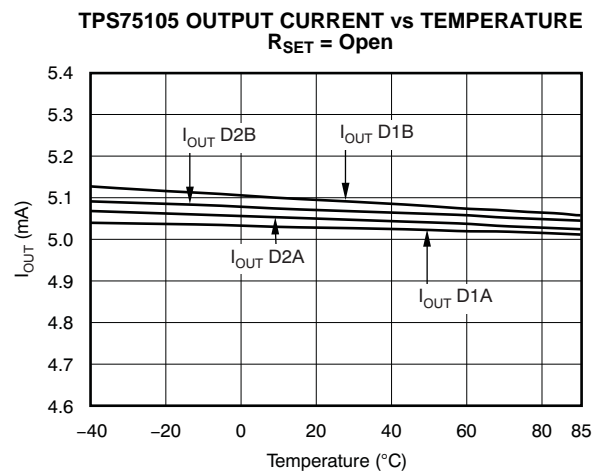

Figure 11.

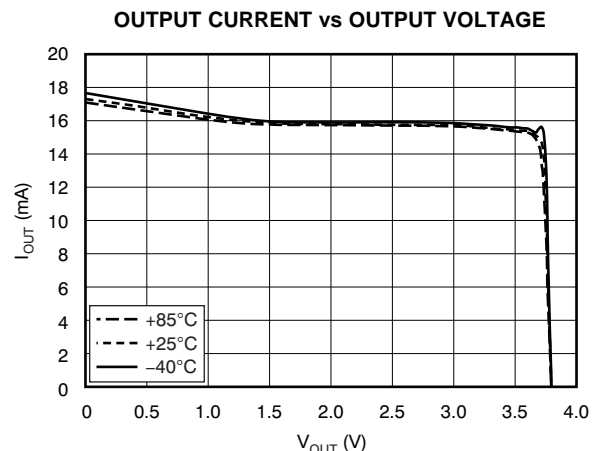

Figure 12.

APPLICATIONS INFORMATION

SETTING THE OUTPUT CURRENT LEVEL

The TPS7510x is a quad matched current source. Each of the four current source output levels is set by a single reference current. An internal voltage reference of 1.225V (nominal) in combination with a resistor sets the reference current level. This reference current is then mirrored onto each of the four outputs with a ratio of typically 420:1. The resistor required to set the LED current is calculated using [Equation 1](#):

$$R_{ISET} = \frac{K \times V_{ISET}}{I_{LED}} \quad (1)$$

where:

- K is the current ratio
- V_{ISET} is the internal reference voltage
- I_{LED} is the desired LED current

For example, to set the LED current level to 10mA, a resistor value of 51.1k Ω is required. This value sets up a reference current of 23.9 μ A (1.22V/51.1k Ω). In turn, this reference current is mirrored to each output current source, resulting in an output current of 10mA (23.9 μ A \times 420).

The TPS7510x offers two methods for setting the output current levels. The LED current is set either by connecting a resistor (calculated using [Equation 1](#)) from the I_{SET} pin to GND, or leaving I_{SET} unconnected to employ the factory-programmed R_{SET} resistance. The internal programmed resistance is implemented using high-precision processing and yields a reference current accuracy of 0.5%, nominal. Accuracy using external resistors is subject to the tolerance of the external resistor and the accuracy of the internal reference voltage.

The TPS7510x automatically detects the presence of an external resistor by monitoring the current out of the I_{SET} pin. Current levels in excess of 3 μ A signify the presence of an external resistor and the device uses the external resistor to set the reference current. If the current from I_{SET} is less than 3 μ A, the device defaults to the preset internal reference set resistor. The TPS7510x is available with eight preset current levels, from 3mA to 10mA (per output) in 1mA increments. Solutions using the preset internal current level eliminate an external component, thereby increasing accuracy and reducing cost.

LIMITATIONS ON LED FORWARD VOLTAGES

The TPS7510x is a linear current source implementing LDO regulator building blocks. Therefore, there are some limitations to the forward (output) voltages that can be used while maintaining accurate operation. The first limitation is the maximum LED forward voltage. Because LDO technology is employed, there is the dropout voltage to consider. The TPS7510x is an ultra-low dropout device with typical dropouts in the range of 30mV at 5mA. Care must be taken in the design to ensure that the difference between the lowest possible input voltage (for example, battery cut-off) and the highest possible forward voltage yields at least 100mV of headroom. Headroom levels less than dropout decrease the accuracy of the current source (see [Figure 6](#)).

The other limitation to consider is the minimum output voltage required to yield accurate operation. The current source employs NMOS MOSFETs, and a minimum forward LED voltage of approximately 1.5V on the output is required to maintain highest accuracy. The TPS7510x is ideal for white LEDs and color LEDs with forward voltages greater than 1.5V. This range includes red LEDs that have typical forward voltages of 1.7V.

USE OF EXTERNAL CAPACITORS

The TPS7510x does not require the use of any external capacitors for stable operation. Nominal stray and/or power-supply decoupling capacitance on the input is adequate for stable operation. Capacitors are not recommended on the outputs because they are not needed for stability.

USE OF UNUSED OUTPUTS OR TYING OUTPUTS TOGETHER

Unused outputs may be left unconnected or tied to the V_{IN} supply. While open outputs are acceptable, tying unused outputs to the V_{IN} supply increases ESD protection. Connecting unused output to ground violates the minimum recommended output voltage, results in current levels that potentially exceed the set/preset LED current and should be avoided.

Connecting outputs in parallel is an acceptable way of increasing the amount of LED current drive. This configuration is a useful trick when the higher current level is a multiple of the preset value.

USE OF ENABLE PINS FOR PWM DIMMING

The TPS7510x divides control of the LED outputs into two banks of two current sources each. Each bank is controlled by the use of an independent, active-high enable pin (ENA and ENB). The enable pin can be used for standard ON/OFF operation of the current source, driven by standard logic levels from processor GPIO pins, for example. Drive EN high to turn on the bank of LEDs; drive EN low to turn off the bank of LEDs.

Another use of the enable pin is for LED dimming. LED brightness is a function of the current level being driven across the diode and the time that current is being driven through the diode. The perceived brightness of an LED can be changed by either varying the current level or, more effectively, by changing the time in which that current is present. When a PWM signal is input into the enable pin, the duty cycle (high or ON time) determines how long the fixed current is driven across the LEDs. Reducing or increasing that duration has the effect of dimming or brightening the LED, without having to employ the more complex method of varying the current level. This technique is particularly useful for reducing LED brightness in low ambient light conditions, where LED brightness is not required, thereby decreasing current consumption. The enable pins can also be used for LED blinking, varying blink rates based on system status.

Although providing many useful applications, PWM dimming does have a minimum duty cycle required to achieve the required current level. The recommended minimum on time of the TPS7510x is approximately 33µs. On times less than 33µs result in reductions in the output current by not allowing enough time for the output to reach the desired current level. Also, having both enables switching together, asynchronously, or having one enable on at all times, impacts the minimum recommended on time (see Figure 4 and Figure 5). If one enable is already on, the speed at which the other channel turns on is faster than if both channels were turning on together or if the other channel is off. Therefore, connecting one enable on allows for approximately 10µs to 12µs shorter minimum on times of the switching enable channel.

Unused enable pins can be left unconnected or connected to ground to minimize current

consumption. Connecting unused enable pins to ground increases ESD protection. If connected to V_{IN} , a small amount of current drains through the enable input (see the [Electrical Characteristics](#) table).

LOAD REGULATION

The TPS7510x is designed to provide very tight load regulation. In the case of a fixed current source, the output load change is a change in voltage. Tight load regulation means that output voltages (LED forward voltages) with large variations can be used without impacting the fixed current being sourced by the output or the output-to-output current matching. The permissible variation on the output not only allows for large variations in white LED forward voltages, but even permits the use of different color LEDs on different outputs with minimal effect on output current.

LINE REGULATION

The TPS7510x is also designed to provide very tight line regulation. This architecture allows for voltage transient events to occur on the power supply (battery) without impacting the fixed output current levels or the output to output current matching. A prime example of such a supply transient event is the occurrence of a transmit pulse on the radio of a mobile handset. These transient pulses can cause variations of 300mV and 600mV on the supply to the TPS7510x. The line regulation limitation is that the lower supply voltage level of the event does not cause the input to output voltage difference to drop below the dropout voltage range.

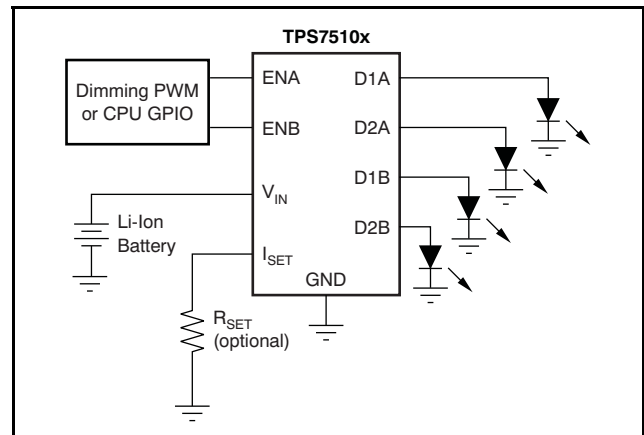

Figure 13. Typical Application Diagram

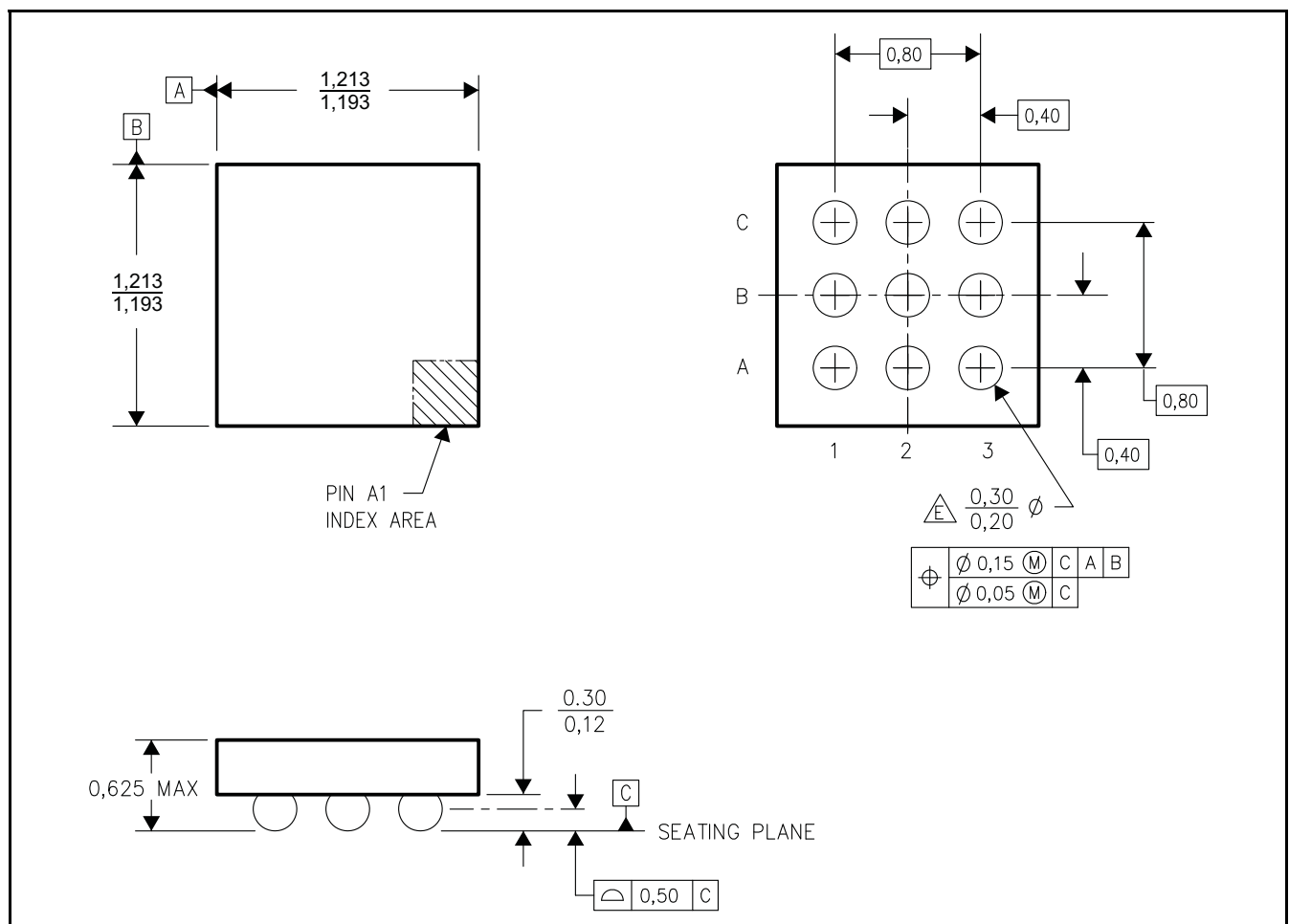

Figure 14. YFF Wafer Chip-Scale Package Dimensions (in mm)

PACKAGING INFORMATION

| Orderable Device | Status ⁽¹⁾ | Package Type | Package Drawing | Pins | Package Qty | Eco Plan ⁽²⁾ | Lead/Ball Finish | MSL Peak Temp ⁽³⁾ |
|------------------|-----------------------|--------------|-----------------|------|-------------|-------------------------|------------------|------------------------------|
| TPS75103YFFR | ACTIVE | DSBGA | YFF | 9 | 3000 | Green (RoHS & no Sb/Br) | SNAG | Level-1-260C-UNLIM |
| TPS75103YFFT | ACTIVE | DSBGA | YFF | 9 | 250 | Green (RoHS & no Sb/Br) | SNAG | Level-1-260C-UNLIM |
| TPS75105YFFR | ACTIVE | DSBGA | YFF | 9 | 3000 | Green (RoHS & no Sb/Br) | Call TI | Level-1-260C-UNLIM |
| TPS75105YFFT | ACTIVE | DSBGA | YFF | 9 | 250 | Green (RoHS & no Sb/Br) | Call TI | Level-1-260C-UNLIM |

⁽¹⁾ The marketing status values are defined as follows:

ACTIVE: Product device recommended for new designs.

LIFEBUY: TI has announced that the device will be discontinued, and a lifetime-buy period is in effect.

NRND: Not recommended for new designs. Device is in production to support existing customers, but TI does not recommend using this part in a new design.

PREVIEW: Device has been announced but is not in production. Samples may or may not be available.

OBSOLETE: TI has discontinued the production of the device.

⁽²⁾ Eco Plan - The planned eco-friendly classification: Pb-Free (RoHS), Pb-Free (RoHS Exempt), or Green (RoHS & no Sb/Br) - please check <http://www.ti.com/productcontent> for the latest availability information and additional product content details.

TBD: The Pb-Free/Green conversion plan has not been defined.

Pb-Free (RoHS): TI's terms "Lead-Free" or "Pb-Free" mean semiconductor products that are compatible with the current RoHS requirements for all 6 substances, including the requirement that lead not exceed 0.1% by weight in homogeneous materials. Where designed to be soldered at high temperatures, TI Pb-Free products are suitable for use in specified lead-free processes.

Pb-Free (RoHS Exempt): This component has a RoHS exemption for either 1) lead-based flip-chip solder bumps used between the die and package, or 2) lead-based die adhesive used between the die and leadframe. The component is otherwise considered Pb-Free (RoHS compatible) as defined above.

Green (RoHS & no Sb/Br): TI defines "Green" to mean Pb-Free (RoHS compatible), and free of Bromine (Br) and Antimony (Sb) based flame retardants (Br or Sb do not exceed 0.1% by weight in homogeneous material)

⁽³⁾ MSL, Peak Temp. -- The Moisture Sensitivity Level rating according to the JEDEC industry standard classifications, and peak solder temperature.

Important Information and Disclaimer:The information provided on this page represents TI's knowledge and belief as of the date that it is provided. TI bases its knowledge and belief on information provided by third parties, and makes no representation or warranty as to the accuracy of such information. Efforts are underway to better integrate information from third parties. TI has taken and continues to take reasonable steps to provide representative and accurate information but may not have conducted destructive testing or chemical analysis on incoming materials and chemicals. TI and TI suppliers consider certain information to be proprietary, and thus CAS numbers and other limited information may not be available for release.

In no event shall TI's liability arising out of such information exceed the total purchase price of the TI part(s) at issue in this document sold by TI to Customer on an annual basis.

RGT (S-PQFP-N16)

PLASTIC QUAD FLATPACK

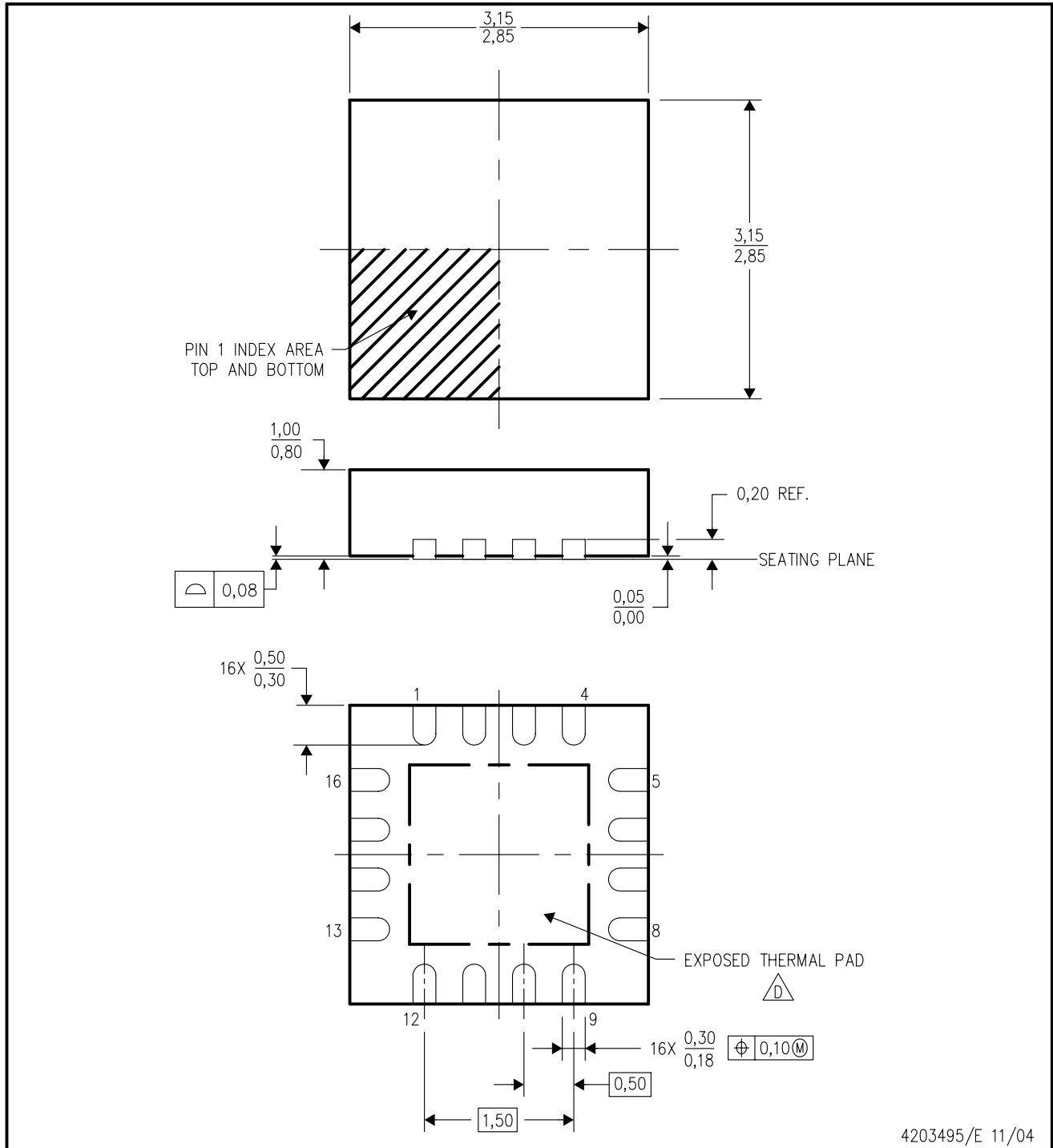

4203495/E 11/04

- NOTES:
- A. All linear dimensions are in millimeters. Dimensioning and tolerancing per ASME Y14.5M-1994.
 - B. This drawing is subject to change without notice.
 - C. Quad Flatpack, No-leads (QFN) package configuration.
 -  D. The package thermal pad must be soldered to the board for thermal and mechanical performance. See the Product Data Sheet for details regarding the exposed thermal pad dimensions.
 - E. Falls within JEDEC MO-220.

YFF (S-XBGA-N9)

DIE-SIZE BALL GRID ARRAY

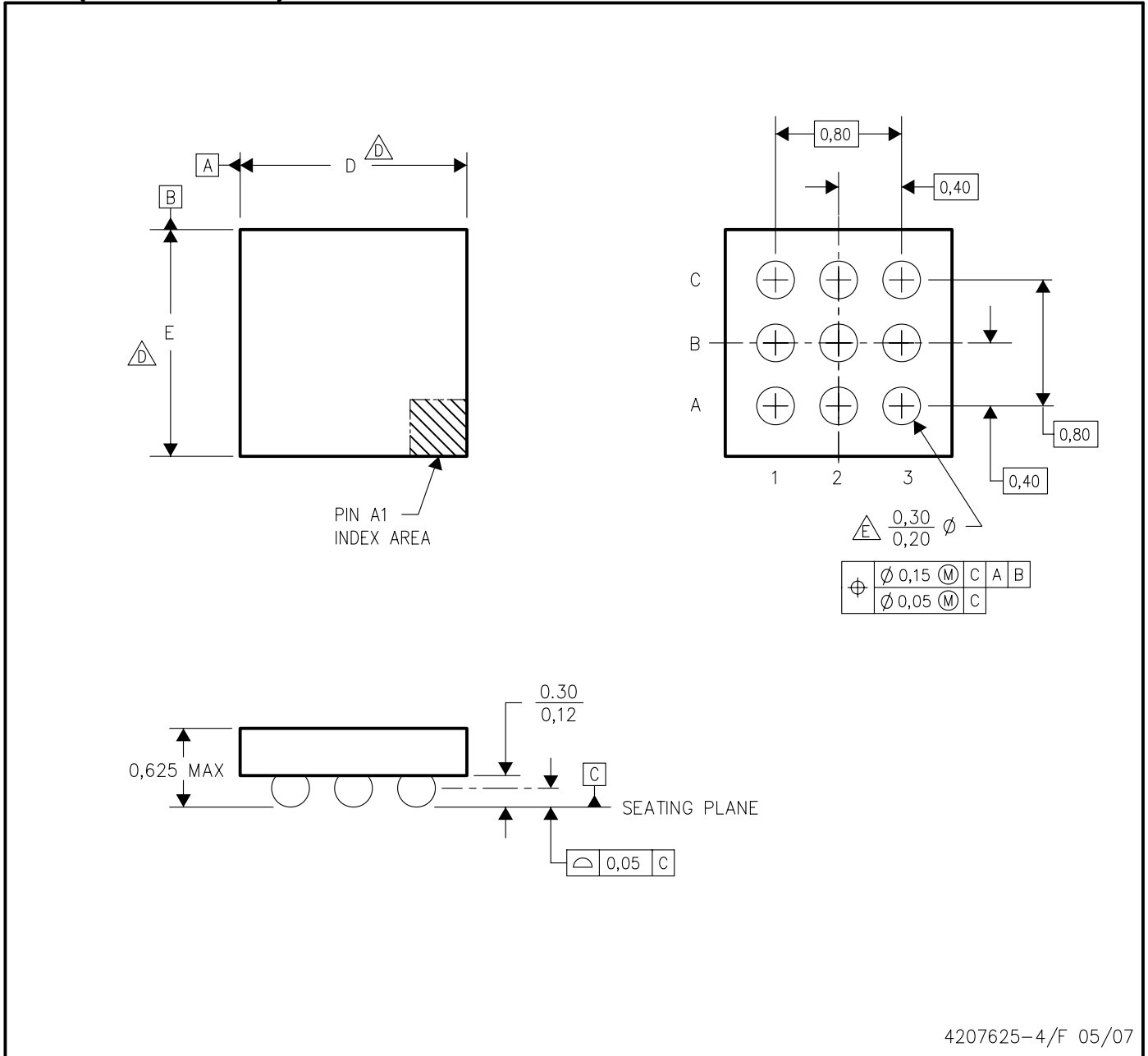

- NOTES:
- A. All linear dimensions are in millimeters.
 - B. This drawing is subject to change without notice.
 - C. NanoFree™ package configuration.
 - $\triangle D$ Devices in YFF package can have dimensions D ranging from 1.15 to 1.60 mm and dimension E ranging from 1.15 to 1.60 mm. To determine the exact package size of a particular device, refer to the device datasheet or contact a local TI representative.
 - $\triangle E$ Reference Product Data Sheet for array population. 3 x 3 matrix pattern is shown for illustration only.
 - F. This package contains lead-free balls.

NanoFree is a trademark of Texas Instruments.

IMPORTANT NOTICE

Texas Instruments Incorporated and its subsidiaries (TI) reserve the right to make corrections, modifications, enhancements, improvements, and other changes to its products and services at any time and to discontinue any product or service without notice. Customers should obtain the latest relevant information before placing orders and should verify that such information is current and complete. All products are sold subject to TI's terms and conditions of sale supplied at the time of order acknowledgment.

TI warrants performance of its hardware products to the specifications applicable at the time of sale in accordance with TI's standard warranty. Testing and other quality control techniques are used to the extent TI deems necessary to support this warranty. Except where mandated by government requirements, testing of all parameters of each product is not necessarily performed.

TI assumes no liability for applications assistance or customer product design. Customers are responsible for their products and applications using TI components. To minimize the risks associated with customer products and applications, customers should provide adequate design and operating safeguards.

TI does not warrant or represent that any license, either express or implied, is granted under any TI patent right, copyright, mask work right, or other TI intellectual property right relating to any combination, machine, or process in which TI products or services are used. Information published by TI regarding third-party products or services does not constitute a license from TI to use such products or services or a warranty or endorsement thereof. Use of such information may require a license from a third party under the patents or other intellectual property of the third party, or a license from TI under the patents or other intellectual property of TI.

Reproduction of TI information in TI data books or data sheets is permissible only if reproduction is without alteration and is accompanied by all associated warranties, conditions, limitations, and notices. Reproduction of this information with alteration is an unfair and deceptive business practice. TI is not responsible or liable for such altered documentation. Information of third parties may be subject to additional restrictions.

Resale of TI products or services with statements different from or beyond the parameters stated by TI for that product or service voids all express and any implied warranties for the associated TI product or service and is an unfair and deceptive business practice. TI is not responsible or liable for any such statements.

TI products are not authorized for use in safety-critical applications (such as life support) where a failure of the TI product would reasonably be expected to cause severe personal injury or death, unless officers of the parties have executed an agreement specifically governing such use. Buyers represent that they have all necessary expertise in the safety and regulatory ramifications of their applications, and acknowledge and agree that they are solely responsible for all legal, regulatory and safety-related requirements concerning their products and any use of TI products in such safety-critical applications, notwithstanding any applications-related information or support that may be provided by TI. Further, Buyers must fully indemnify TI and its representatives against any damages arising out of the use of TI products in such safety-critical applications.

TI products are neither designed nor intended for use in military/aerospace applications or environments unless the TI products are specifically designated by TI as military-grade or "enhanced plastic." Only products designated by TI as military-grade meet military specifications. Buyers acknowledge and agree that any such use of TI products which TI has not designated as military-grade is solely at the Buyer's risk, and that they are solely responsible for compliance with all legal and regulatory requirements in connection with such use.

TI products are neither designed nor intended for use in automotive applications or environments unless the specific TI products are designated by TI as compliant with ISO/TS 16949 requirements. Buyers acknowledge and agree that, if they use any non-designated products in automotive applications, TI will not be responsible for any failure to meet such requirements.

Following are URLs where you can obtain information on other Texas Instruments products and application solutions:

| Products | | Applications | |
|-----------------------|--|---------------------|--|
| Amplifiers | amplifier.ti.com | Audio | www.ti.com/audio |
| Data Converters | dataconverter.ti.com | Automotive | www.ti.com/automotive |
| DSP | dsp.ti.com | Broadband | www.ti.com/broadband |
| Interface | interface.ti.com | Digital Control | www.ti.com/digitalcontrol |
| Logic | logic.ti.com | Military | www.ti.com/military |
| Power Mgmt | power.ti.com | Optical Networking | www.ti.com/opticalnetwork |
| Microcontrollers | microcontroller.ti.com | Security | www.ti.com/security |
| RFID | www.ti-rfid.com | Telephony | www.ti.com/telephony |
| Low Power Wireless | www.ti.com/lpw | Video & Imaging | www.ti.com/video |
| | | Wireless | www.ti.com/wireless |

Mailing Address: Texas Instruments, Post Office Box 655303, Dallas, Texas 75265
Copyright © 2007, Texas Instruments Incorporated