

8-Bit Microcontroller for Digital Computer Monitors

1. Introduction

The TSC8051C1 is a stand-alone high performance CMOS 8-bit embedded microcontroller and is designed for use in CRT monitors. It is also suitable for automotive and industrial applications.

The TSC8051C1 includes the fully static 8-bit "80C51" CPU core with 256 bytes of RAM; 8 Kbytes of ROM; two 16-bit timers; 12 PWM Channels; a 6 sources and 2-level interrupt controller; a full duplex serial port; a full I²CTM* interface; a watchdog timer and on-chip oscillator.

In addition, the TSC8051C1 has 2 software selectable modes of reduced activity for further reduction in power consumption. In the idle mode the CPU is frozen while the RAM, the timers, the serial ports, and the interrupt system continue to function. In the power down mode the RAM is saved and all other functions are inoperative.

The TSC8051C1 enables the users reducing a lot of external discrete components while bringing the maximum of flexibility.

2. Features

- Boolean processor
- Fully static design
- 8K bytes of ROM
- 256 bytes of RAM
- 2 x 16-bit timer/counter
- Programmable serial port
- Programmable Multimaster I²C controller
- 6 interrupt sources:
 - External interrupts (2)
 - Timers interrupt (2)
 - Serial port interrupt
 - I²C interrupt
- Watchdog reset
- On chip oscillator for crystal or ceramic resonator
- 2 power saving control modes:
 - Idle mode
 - Power-down mode
- Controlled HSYNC & VSYNC outputs
- Up to 12 programmable PWM channels with 8-bit resolution
- Up to 32 programmable I/O lines depending on the package
- 40 pins DIP, 44 pins PQFP, 44 and 52 pins PLCC packages
- Commercial and industrial temperature ranges
- Operating Frequency: 12 MHz to 16 MHz

* I²C is a trademark of PHILIPS Corporation

3. Block Diagram

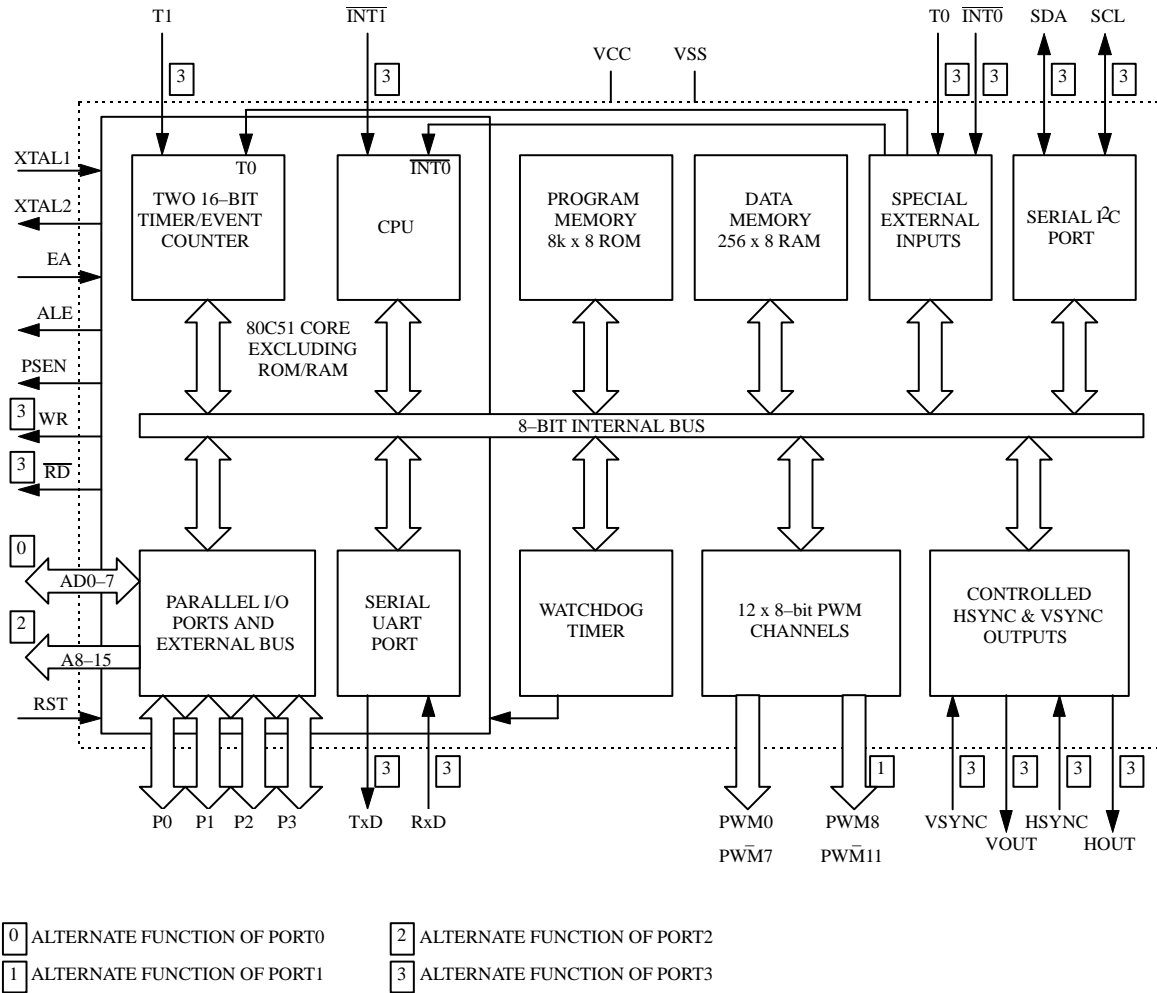
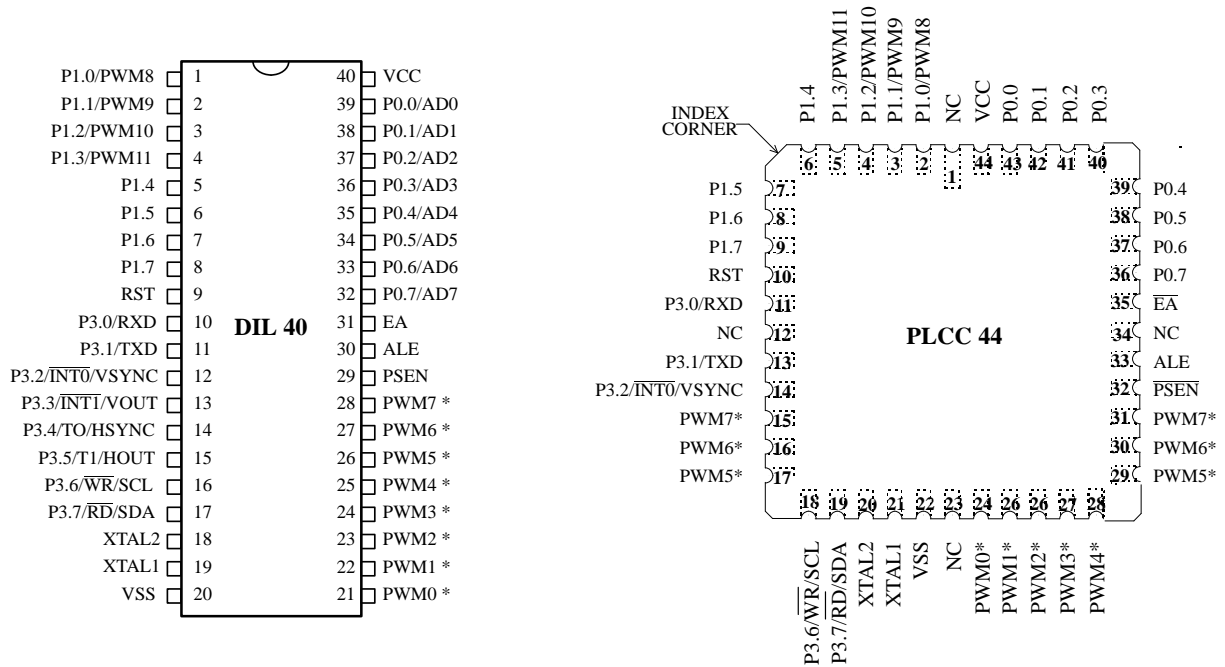

Figure 1. TSC8051C1 block diagram.

4. Pin Configurations



*PWMx or P2.x depending on option (see ordering information)

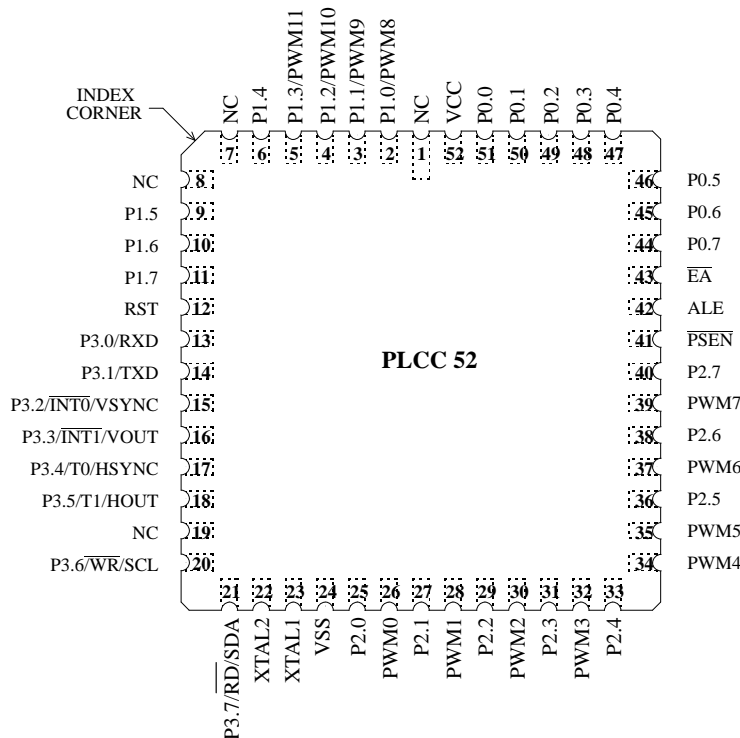

Figure 2. TSC8051C1 pin configurations.

5. Pin Description

VSS

Circuit ground.

VCC

Power supply voltage.

RST

A high level on this pin for two machine cycles while the oscillator is running resets the device. An internal pulldown resistor permits power-on reset using only a capacitor connected to VCC.

PORT 0 (P0.0–P0.7)

Port 0 is an 8-bit open-drain bidirectional I/O port. Port 0 pins that have 1's written to them float, and in that state can be used as high-impedance inputs.

Port 0 is also the multiplexed low-order address and data bus during access to external Program and Data memory. In this application it uses strong internal pull-up when emitting 1's.

Port 0 can sink and source 8 LS TTL loads.

PORT 1 (P1.0–P1.7)

Port 1 is an 8-bit bidirectional I/O port with internal pullups. Port 1 pins that have 1's written to them are pulled high by the internal pullups, and in that state can be used as inputs. As inputs, Port 1 pins that are externally being pulled low will source current (IIL on the data-sheet) because of the internal pullups.

Port 1 also serves 4 programmable PWM open drain outputs, as listed below:

Port Pin	Alternate Function
P1.0	PWM8: Pulse Width Modulation output 8.
P1.1	PWM9: Pulse Width Modulation output 9.
P1.2	PWM10: Pulse Width Modulation output 10.
P1.3	PWM11: Pulse Width Modulation output 11.

Port 1 can sink and source 3 LS TTL loads.

PORT 2 (P2.0–P2.7)

Port 2 is an 8-bit bidirectional I/O port with internal pullups. Port 2 pins that have 1's written to them are pulled high by the internal pullups, and in that state can be used as inputs. As inputs, Port 2 pins that are externally being pulled low will source current (IIL on the data-sheet) because of the internal pullups.

Port 2 emits the high-order 8-bit address during fetches from external Program Memory and during accesses to external Data Memory that use 16-bit addresses. In this application it uses strong internal pull-up when emitting 1's.

Port 2 can sink and source 3 LS TTL loads.

PORT 3 (P3.0–P3.7)

Port 3 is an 8-bit bidirectional I/O port with internal pullups. Port 3 pins that have 1's written to them are pulled high by the internal pullups, and in that state can be used as inputs. As inputs, Port 3 pins that are externally being pulled low will source current (IIL on the data-sheet) because of the internal pullups.

Each line on this port has 2 or 3 functions either a general I/O or special control signal, as listed below:

Port Pin	Alternate Function
P3.0	RXD: serial input port.
P3.1	TXD: serial output port.
P3.2	$\overline{\text{INT0}}$: external interrupt 0. VSYNC: vertical synchro input.
P3.3	$\overline{\text{INT1}}$: external interrupt 1. VOUT: buffered V-SYNC output.
P3.4	T0: Timer 0 external input. HSYNC: horizontal synchro input.
P3.5	T1: Timer 1 external input. HOUT: buffered H-SYNC output.
P3.6	$\overline{\text{WR}}$: external data memory write strobe. SCL: serial port clock line I ² C bus.
P3.7	$\overline{\text{RD}}$: external data memory read strobe. SDA: serial port data line I ² C bus.

Port 3 can sink and source 3 LS TTL loads.

PWM0–7

These eight Pulse Width Modulation outputs are true open drain outputs and are floating after reset.

ALE

The Address Latch Enable output signal occurs twice each machine cycle except during external data memory access. The negative edge of ALE strobes the address into external data memory or program memory. ALE can sink and source 8 LS TTL loads.

If desired, ALE operation can be disabled by setting bit 0 of SFR location AFh (MSCON). With the bit set, ALE is active only during MOVX instruction and external fetches. Otherwise the pin is pulled low.

$\overline{\text{EA}}$

When the External Access input is held high, the CPU executes out of internal program memory (unless the Program Counter exceeds 1FFFh). When $\overline{\text{EA}}$ is held low the CPU executes only out of external program memory. $\overline{\text{EA}}$ must not be left floating.

$\overline{\text{PSEN}}$

The Program Store Enable output signal remains high during internal program memory. An active low output occurs during an external program memory fetch. $\overline{\text{PSEN}}$ can sink and source 8 LS TTL loads.

XTAL1

Input to the inverting oscillator amplifier and input to the external clock generator circuits.

XTAL2

Output from the inverting oscillator amplifier. This pin should be non-connected when external clock is used.

6. Basic Functional Description

6.1. Idle And Power Down Operation

Figure 3 shows the internal Idle and Power Down clock configuration. As illustrated, Power Down operation stops the oscillator. Idle mode operation allows the interrupt, serial port, and timer blocks to continue to operate while the clock to the CPU is gated off.

These special modes are activated by software via the Special Function Register, its hardware address is 87h. PCON is not bit addressable.

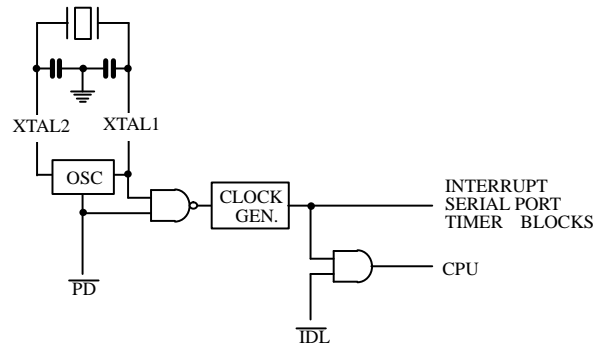

Figure 3. Idle and Power Down Hardware.

PCON: Power Control Register

MSB		SFR 87h				LSB	
SMOD	-	-	-	GF1	GF0	PD	IDL

Symbol	Position	Name and Function
IDL	PCON.0	Idle mode bit. Setting this bit activates idle mode operation.
PD	PCON.1	Power Down bit. Setting this bit activates power down operation.
GF0	PCON.2	General-purpose flag bit.
GF1	PCON.3	General-purpose flag bit.
-	PCON.4	(Reserved).
-	PCON.5	(Reserved).
-	PCON.6	(Reserved).
SMOD	PCON.7	Double Baud rate bit. Setting this bit causes the baud rate to double when the serial port is being used in either modes 1, 2 or 3.

If 1's are written to PD and IDL at the same time, PD takes precedence. The reset value of PCON is 0XXX0000b.

6.1.1. Idle Mode

The instruction that sets PCON.0 is the last instruction executed before the Idle mode is activated. Once in the Idle mode the CPU status is preserved in its entirety: the Stack Pointer, Program Counter, Program Status Word, Accumulator, RAM, and all other register maintain their data during Idle Table 1 describes the status of the external pins during Idle mode.

There are two ways to terminate the Idle mode. Activation of any enabled interrupt will cause PCON.0 to be cleared by hardware terminating Idle mode. The interrupt is serviced, and following RETI, the next instruction to be executed will be the one following the instruction that wrote 1 to PCON.0.

The flag bits GF0 and GF1 may be used to determine whether the interrupt was received during normal execution or during the Idle mode. For example, the instruction that writes to PCON.0 can also set or clear one or both flag bits. When Idle mode is terminated by an enabled interrupt, the service routine can examine the status of the flag bits.

The second way of terminating the Idle is with a hardware reset. Since the oscillator is still running, the hardware reset needs to be active for only 2 machine cycles (24 oscillator periods) to complete the reset operation.

6.1.2. Power Down Mode

The instruction that sets PCON.1 is the last executed prior to entering power down. Once in power down, the oscillator is stopped. The contents of the onchip RAM and the Special Function Register are saved during power down mode. A hardware reset is the only way of exiting the power down mode. The hardware reset initiates the Special Function Register. In the Power Down mode, VCC may be lowered to minimize circuit power consumption. Care must be taken to ensure the voltage is not reduced until the power down mode is entered, and that the voltage is restored before the hardware reset is applied which frees the oscillator. Reset should not be released until the oscillator has restarted and stabilized. Table 1 describes the status of the external pins while in the power down mode. It should be noted that if the power down mode is activated while in external program memory, the port data that is held in the Special Function Register P2 is restored to Port 2. If the data is a 1, the port pin is held high during the power down mode by the strong pullup transistor.

Table 1. Status of the external pins during Idle and Power Down modes.

Mode	Program Memory	ALE	PSEN	Port 0	Port 1	Port 2	Port 3	PWMx
Idle	Internal	1	1	Port Data	Port Data	Port Data	Port Data	Floating
Idle	External	1	1	Floating	Port Data	Address	Port Data	Floating
Power Down	Internal	0	0	Port Data	Port Data	Port Data	Port Data	Floating
Power Down	External	0	0	Floating	Port Data	Port Data	Port Data	Floating

6.2. Stop Clock Mode

Due to static design, the TSC8051C1 clock speed can be reduced down to 0 MHz without any data loss in memory or register. This mode allows step by step code execution, and permits to reduce system power consumption by bringing the clock frequency down to any value. When the clock is stopped, the power consumption is the same as in the Power Down Mode.

6.3. I/O Ports Structure

The TSC8051C1 has four 8-bit ports. Each port consist of a latch (special function register P0 to P3), an input buffer and an output driver. These ports are the same as in 80C51, with the exception of the additional functions of port 1 and port 3 (see Pin Description section).

6.4. I/O Configurations

Figure 4. shows a functional diagram of the generic bit latch and I/O buffer in each of the four ports. The bit latch, (one bit in the port SFR) is represented as a D type flip-flop. A 'write to latch' signal from the CPU latches a bit from the internal bus and a 'read latch' signal from the CPU places the Q output of the flip-flop on the internal bus. A 'read pin' signal from the CPU places the actual pin logical level on the internal bus. Some instructions that read a port read the actual pin, and other instructions read the latch (SFR).

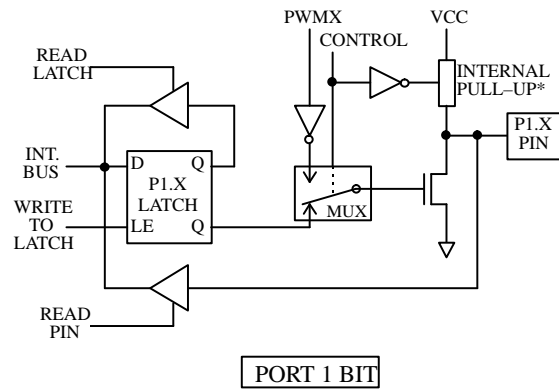
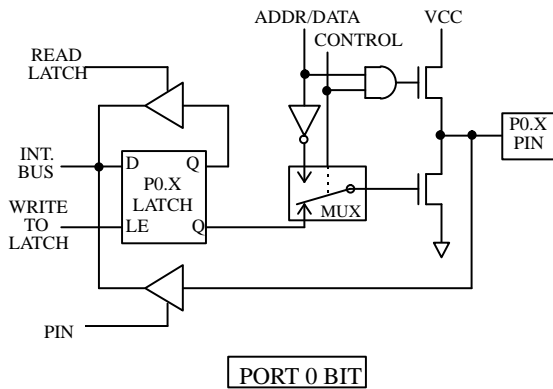

* Internal pull-up not present on P1.0 to P1.3 when PWM8 to PWM11 are enabled

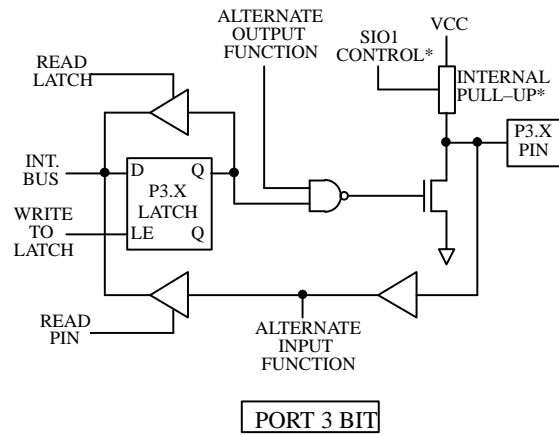
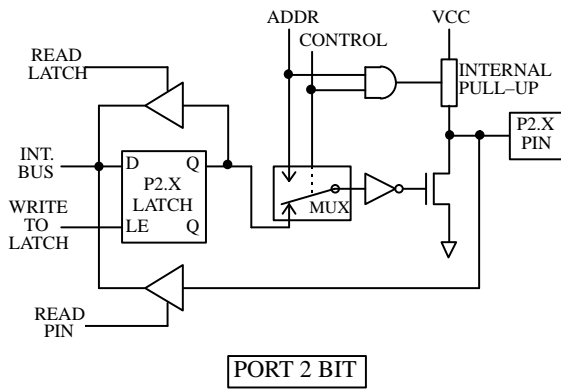

* Internal pull-up not present on P3.6 and P3.7 when SIO1 is enabled.

Figure 4. Port Bit Latches and I/O buffers

6.5. Reset Circuitry

The reset circuitry for the TSC8051C1 is connected to the reset pin RST. A Schmitt trigger is used at the input for noise rejection (see Figure 5.).

A reset is accomplished by holding the RST pin high for at least two machine cycles (24 oscillator periods) while the oscillator is running. The CPU responds by executing an internal reset. It also configures the ALE and PSEN pins as inputs (they are quasi-bidirectional). A Watchdog timer underflow if enabled, will force a reset condition to the TSC8051C1 by an internal connection.

The internal reset is executed during the second cycle in which reset is high and is repeated every cycle until RST goes low. It leaves the internal registers as follows:

Register	Content
ACC	00h
B	00h
DPTR	0000h
EICON	00h
HWDR	00h
IE	0X000000b
IP	XX000000b
MSCON	XXXXXXXX0b
MXCR0-1	00h
P0-P3	FFh

Register	Content
PC	0000h
PCON	0XXX0000b
PSW	00h
PWM0-11	00h
PWMCON	XXXXXXXX0b
S1CON	00h
S1DAT	00h
S1STA	F8h
SBUF	00h
SCON	00h
SOCR	00h
SP	07h
TCON	00h
TH0, TH1	00h
TL0, TL1	00h
TMOD	00h

The internal RAM is not affected by reset. At power-on reset, the RAM content is indeterminate.

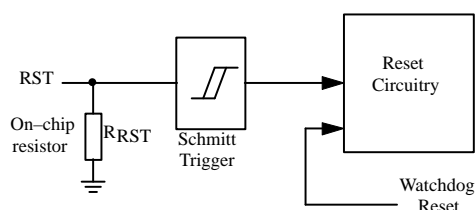

Figure 5. On-Chip Reset Configuration.

An automatic reset can be obtained when VCC is turned on by connecting the RST pin to VCC through a 1 μ F capacitor providing the VCC setting time does not exceed 1ms and the oscillator start-up time does not exceed 10ms. This power-on reset circuit is shown in Figure 6. When power comes on, the current drawn by RST starts to charge the capacitor. The voltage at RST is the difference between VCC and the capacitor voltage, and decreases from VCC as the capacitor charges. VRST must remain above the lower threshold of the Schmitt trigger long enough to effect a complete reset. The time required is the oscillator start-up time, plus 2 machine cycles.

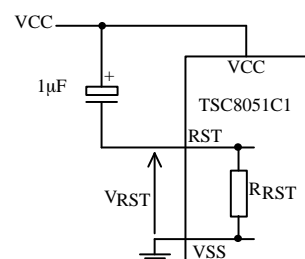

Figure 6. Power-on Reset Circuit

6.6. Oscillator Characteristics

XTAL1 and XTAL2 are respectively the input and output of an inverting amplifier which is configured for use as an on-chip oscillator. As shown in Figure 7, either a quartz crystal or ceramic resonator may be used. To drive the device from an external clock source, XTAL1 should be driven while XTAL2 is left unconnected as shown in Figure 8.

There are no requirements on the duty cycle of the external clock signal, since the input to the internal clocking circuitry is through a divide-by-two flip-flop. The minimum high and low times specified on the data sheet must be observed however.

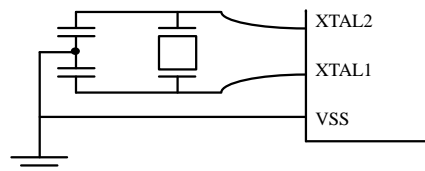

Figure 7. Crystal Oscillator

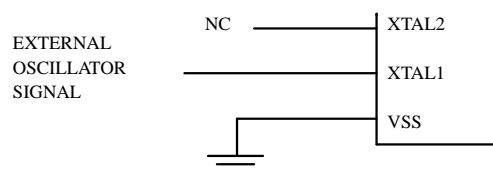

Figure 8. External Drive Configuration

6.7. Memory organization

The memory organisation of the TSC8051C1 is the same as in the 80C51, with the exception that the TSC8051C1 has 8k bytes ROM, 256 bytes RAM, and additional SFRs. Details of the differences are given in the following paragraphs.

In the TSC8051C1, the lowest 8k of the 64k program memory address space is filled by internal ROM. Depending on the package used, external access is available or not. By tying the \overline{EA} pin high, the processor fetches instructions from internal program ROM. Bus expansion for accessing program memory from 8k upward is automatic since external instruction fetches occur automatically when the program counter exceeds 1FFFh. If the \overline{EA} pin is tied low, all program memory fetches are from external memory. The execution speed is the same regardless of whether fetches are from external or internal program memory. If all storage is on-chip, then byte location 1FFFh should be left vacant to prevent an undesired pre-fetch from external program memory address 2000h.

Certain locations in program memory are reserved for specific purposes. Locations 0000h to 0002h are reserved for the initialisation program. Following reset, the CPU always begins execution at location 0000h. Locations 0003h to 0032h are reserved for the six interrupt request service routines.

The internal data memory space is divided into a 256-bytes internal RAM address space and a 128 bytes special function register address space.

The internal data RAM address space is 0 to FFh. Four 8-bit register banks occupy locations 0 to 1Fh. 128 bit locations of the internal data RAM are accessible through direct addressing. These bits reside in 16 bytes of internal RAM at location 20h to 2Fh. The stack can be located anywhere in the internal data RAM address space by loading the 8-bit stack pointer (SP SFR).

The SFR address space is 100h to 1FFh. All registers except the program counter and the four 8-bit register banks reside in this address space. Memory mapping of the SFRs allows them to be accessed as easily as internal RAM, and as such, they can be operated on by most instructions. The mapping in the SFR address space of the 43 SFRs is shown in Table 2. The SFR names in *italic* are TSC8051C1 new SFRs and are described in Peripherals Functional Description section. The SFR names in **bold** are bit addressable.

Table 2. Mapping of Special Function Register

	0/8	1/9	2/A	3/B	4/C	5/D	6/E	7/F
F8					<i>PWM8</i>	<i>PWM9</i>	<i>PWM10</i>	<i>PWM11</i>
F0	B				<i>PWM4</i>	<i>PWM5</i>	<i>PWM6</i>	<i>PWM7</i>
E8					<i>PWM0</i>	<i>PWM1</i>	<i>PWM2</i>	<i>PWM3</i>
E0	ACC				<i>EICON</i>	<i>SOCR</i>	<i>HWDR</i>	<i>MXCR0</i>
D8	<i>SICON</i>	<i>SISTA</i>	<i>SIDAT</i>					<i>PWMCON</i>
D0	PSW							<i>MXCR1</i>
C8								
C0								
B8	IP							
B0	P3							
A8	IE							<i>MSCON</i>
A0	P2							
98	SCON	SBUF						
90	P1							
88	TCON	TMOD	TL0	TL1	TH0	TH1		
80	P0	SP	DPL	DPH				PCON

6.8. Interrupts

The TSC8051C1 has six interrupt sources, each of which can be assigned one of two priority levels. The five interrupt sources common to the 80C51 are the external interrupts (INT0 and INT1), the timer 0 and timer 1 interrupts (IT0 and IT1), and the serial I/O interrupt (RI or TI). In the TSC8051C1, the standard serial I/O is called SIO0.

The SIO1 (I²C) interrupt is generated by the SI flag in the control register (S1CON SFR). This flag is set when the status register (S1STA SFR) is loaded with a valid status code.

6.8.1. Interrupt Enable Register:

Each interrupt source can be individually enabled or disabled by setting or clearing a bit in the interrupt enable register (IE SFR). All interrupts sources can also be globally enabled or disabled by setting or clearing the EA bit in IE register.

IE: Interrupt Enable Register

MSB		SFR A8h					LSB	
EA	–	ES1	ES0	ET1	EX1	ET0	EX0	

Symbol	Position	Name and Function
EX0	IE.0	Enable external interrupt 0.
ET0	IE.1	Enable timer 0 interrupt.
EX1	IE.2	Enable external interrupt 1.
ET1	IE.3	Enable timer 1 interrupt.
ES0	IE.4	Enable SIO0 (UART) interrupt.
ES1	IE.5	Enable SIO1 (I ² C) interrupt.
–	IE.6	(Reserved).
EA	IE.7	Enable all interrupts.

6.8.2. Interrupt Priority Structure:

Each interrupt source can be assigned one of two priority levels. Interrupt priority levels are defined by the interrupt priority register (IP SFR). Setting a bit in the interrupt priority register selects a high priority interrupt, clearing it selects a low priority interrupt.

IP: Interrupt Priority Register

MSB		SFR B8h					LSB	
–	–	PS1	PS0	PT1	PX1	PT0	PX0	

Symbol	Position	Name and Function
PX0	IP.0	External interrupt 0 priority level.
PT0	IP.1	Timer 0 interrupt priority level.
PX1	IP.2	External interrupt 1 priority level.
PT1	IP.3	Timer 1 interrupt priority level.
PS0	IP.4	SIO0 (UART) interrupt priority level.
PS1	IP.5	SIO1 (I ² C) interrupt priority level.
–	IP.6	(Reserved).
–	IP.7	(Unused).

A low priority interrupt service routine may be interrupted by a high priority interrupt. A high priority interrupt service routine cannot be interrupted by any other interrupt source.

If two requests of different priority levels occur simultaneously, the high priority level request is serviced. If requests of same priority are received simultaneously, an internal polling sequence determines which request is serviced. Thus, within each priority level, there is a second priority structure determined by the polling sequence, as follows:

Order	Source	Priority Within Level
1	INT0	(highest)
2	Timer 0	↑
3	INT1	
4	Timer 1	
5	SIO0	↓
6	SIO1	(lowest)

6.8.3. Interrupt Handling:

The interrupt flags are sampled at S5P2 of every machine cycle. The samples are polled during the following machine cycle. If one of the flags was in a set condition at S5P2 of the previous machine cycle, the polling cycle will find it and the interrupt system will generate a LCALL to the appropriate service routine, provided this hardware-generated LCALL is not blocked by any of the following conditions:

1. An interrupt of higher or equal priority is already in progress.
2. The current (polling) cycle is not the final cycle in the execution of the instruction in progress.
3. The instruction in progress is RETI or any access to the IE or IP SFR.

Any of these three conditions will block the generation of the LCALL to the interrupt service routine. Note that if an interrupt is active but not being responded to for one of the above conditions, if the flag is not still active when the blocking condition is removed, the denied interrupt will not be serviced. In other words, the facts that the interrupt flag was once active but not serviced is not memorized. Every polling cycle is new.

The processor acknowledges an interrupt request by executing a hardware-generated LCALL to the appropriate service routine. In some cases it also clears the flag that generated the interrupt, and in other case it does not. It clears the timer 0, timer 1, and external interrupt flags. An external interrupt flag (IE0 or IE1) is cleared only if it was transition-activated. All other interrupt flags are not cleared by hardware and must be cleared by the software. The LCALL pushes the contents of the program counter onto the stack (but it does not save the PSW) and reloads the PC with an address that depends on the source of the interrupt being vectored to, as listed below:

Source	Vector Address
IE0	0003h
TF0	000Bh
IE1	0013h
TF1	001Bh
RI + TI	0023h
SI	002Bh

Execution proceeds from the vector address until the RETI instruction is encountered. The RETI instruction clears the 'priority level active' flip-flop that was set when this interrupt was acknowledged. It then pops two bytes from the the top of the stack and reloads the program counter with them. Execution of the interrupted program continues from where it was interrupted.

7. Peripherals Functional Description

For detailed functional description of standard 80C51 peripherals, please refer to C51 Family, Hardware Description and Programmer's Guides.

7.1. Watchdog Timer

The watchdog timer consists of a 4-bit timer with a 17-bit prescaler as shown in Figure 9. The prescaler is fed with a signal whose frequency is 1/12 the oscillator frequency (1MHz with a 12MHz oscillator).

The 4-bit timer is decremented every 't' seconds, where: $t = 12 \times 131072 \times 1/fosc$. (131.072ms at $fosc = 12\text{MHz}$). Thus, the interval may vary from 131.072ms to 2097.152ms in 16 possible steps (see Table 3.).

The watchdog timer has to be reloaded (write to HWDR SFR) within periods that are shorter than the programmed watchdog interval, otherwise the watchdog timer will underflow and a system reset will be generated which will reset the TSC8051C1.

HWDR: Hardware WatchDog Register

MSB				SFR E6h				LSB
WTE	-	-	-	WT3	WT2	WT1	WT0	

Symbol	Position	Name and Function
WT0	HWDR.0	Watchdog Timer Interval bit 0.
WT1	HWDR.1	Watchdog Timer Interval bit 1.
WT2	HWDR.2	Watchdog Timer Interval bit 2.
WT3	HWDR.3	Watchdog Timer Interval bit 3.
-	HWDR.4	Reserved for test purpose, must remain to 0 for normal operation.
-	HWDR.5	(Reserved).
-	HWDR.6	(Reserved).
WTE	HWDR.7	Watchdog Timer Enable bit. Setting this bit activates watchdog operation.

Table 3. Watchdog timer interval value format.

WT3	WT2	WT1	WT0	Interval
0	0	0	0	$t \times 16$
0	0	0	1	$t \times 1$
0	0	1	0	$t \times 2$
:	:	:	:	:
:	:	:	:	:
1	1	1	1	$t \times 15$

Once the watchdog timer enabled setting WTE bit, it cannot be disabled anymore, except by a system reset.

The watchdog timer is frozen during idle or power down mode.

HWDR is a write only register. Its value after reset is 00h which disables the watchdog operation.

HWDR is using TSC8051C1 Special Function Register address, E6h.

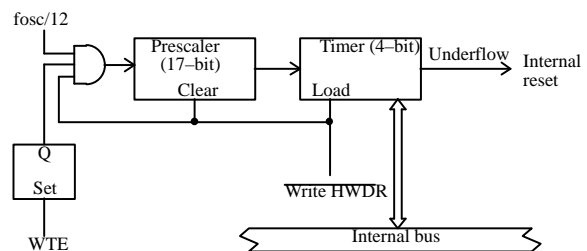

Figure 9. Watchdog timer block diagram

7.2. Pulse Width Modulated Outputs

The TSC8051C1 contains twelve pulse width modulated output channels (see Figure 10.). These channels generate pulses of programmable duty cycle with an 8-bit resolution.

The 8-bit counter counts modulo 256 by default i.e., from 0 to 255 inclusive but can count modulo 254 i.e., from 0 to 253 inclusive by programming the bit 0 of the PWMCON register. The counter clock is supplied by the oscillator frequency. Thus, the repetition frequency f_{pwm} is constant and equals to the oscillator frequency divided by 256 or 254 ($f_{pwm}=46.875\text{KHz}$ or 47.244KHz with a 12MHz oscillator). The 8-bit counter is common to all PWM channels, its value is compared to the contents of the twelve registers: PWM0 to PWM11. Provided the content of each of these registers is greater than the counter value, the corresponding output is set low. If the contents of these registers are equal to, or less than the counter value the output will be high.

PWMx: Pulse Width Modulator x Register

MSB				LSB			
D7	D6	D5	D4	D3	D2	D1	D0

When a compare register (PWM0 to PWM11) is loaded with a new value, the associated output is updated immediately. It does not have to wait until the end of the current counter period. All the PWM outputs are open-drain outputs with standard current drive and standard maximum voltage capability. When they are disabled, eight of them (PWM0 to PWM7) are in high impedance while the other four (PWM8 to PWM11) are standard Port outputs with internal pullups.

PWM0 to PWM11 are write only registers. Their value after reset is 00h.

PWM0 to PWM11 are using TSC8051C1 Special Function Registers addresses as detailed in Table 4.

The pulse-width ratio is therefore defined by the contents of these registers, and is in the range of 0 (all '0' written to PWM register) to 255/256 or 1 (all '1' written to PWM register) and may be programmed in increments of 1/256 or 1/254. When the 8-bit counter counts modulo 254, it can never reach the value of the PWM registers when they are loaded with FEh or FFh.

Table 4. PWM SFR register addresses

Channel	SFR address
PWM0	ECh
PWM1	EDh
PWM2	EEh
PWM3	EFh
PWM4	F4h
PWM5	F5h
PWM6	F6h
PWM7	F7h
PWM8	FCh
PWM9	FDh
PWM10	FEh
PWM11	FFh

Two 8-bit control registers: MXCR0 and MXCR1 are used to enable or disable PWM outputs.

MXCR0 is used for PWM0 to PWM7. MXCR1 is used for PWM8 to PWM11, these PWMs are multiplexed with PORT 1 (see Table 5.)

MXCR0: PWM Multiplexed Control Register 0

MSB		SFR E7h				LSB	
PE7	PE6	PE5	PE4	PE3	PE2	PE1	PE0

Symbol	Position	Name and Function
PE _x	MXCR0.x	PWM _x Enable bit. Setting this bit enables PWM _x output. Clearing this bit disables PWM _x output.

MXCR1: PWM Multiplexed Control Register 1

MSB		SFR D7h				LSB	
-	-	-	-	PE11	PE10	PE9	PE8

Symbol	Position	Name and Function
PE _x	MXCR1.x	PWM _{x+8} Enable bit. Setting this bit enables PWM _x output. Clearing this bit disables PWM _x output and activates the I/O pin (see Table 5).

MXCR0 and MXCR1 are read/write registers. Their value after reset is 00h which corresponds to all PWM disabled.

PWM will not operate in idle and power down modes (frozen counter). When idle or power down mode is entered, the PWM0 to PWM7 output pins are floating and PWM8 to PWM11 pins are set to general purpose P1 port with the value of P1 SFR.

MXCR0 and MXCR1 are using TSC8051C1 Special Function Register addresses, E7h and D7h respectively.

Table 5. PWM alternate pin.

Channel	Pin assignment
PWM8	P1.0
PWM9	P1.1
PWM10	P1.2
PWM11	P1.3

PWMCON is used to control the PWM counter.

PWMCON: PWM Control Register

MSB		SFR DFh				LSB	
-	-	-	-	-	-	-	CMOD

Symbol	Position	Name and Function
CMOD	PWMCON.0	Counter modulo. Setting this bit sets the modulo to 254. Clearing this bit sets the modulo to 256.

PWMCON is a write only register. Its value after reset is 00h which sets the PWM counter modulo to 256.

PWMCON is using TSC8051C1 Special Function Register address, DFh.

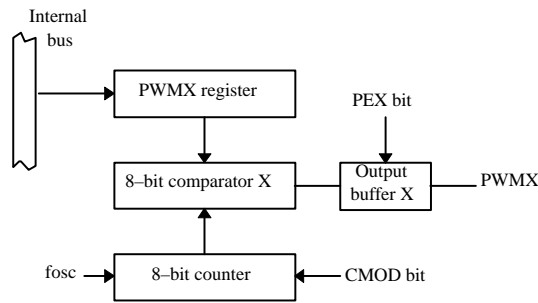

Figure 10. Pulse width modulated outputs block diagram

Figure 11. shows a PWM programming example with PWM register content 55h and counter modulo 256.

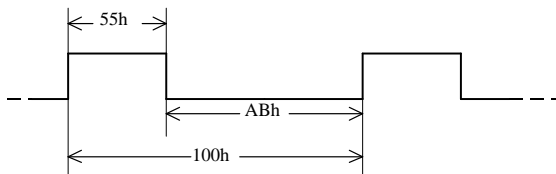

Figure 11. PWM programming example.

SOCR: Synchronisation Output Control Register.

MSB		SFR E5h				LSB	
-	-	VOS	HOS	VOP	VOE	HOP	HOE

Symbol	Position	Name and Function
HOE	SOCR.0	HSYNC Output Enable bit. Setting this bit enables the HSYNC signal.
HOP	SOCR.1	HSYNC Output Polarity bit. Setting this bit inverts the HSYNC output.
VOE	SOCR.2	VSYNC Output Enable bit. Setting this bit enables the VSYNC signal.
VOP	SOCR.3	VSYNC Output Polarity bit. Setting this bit inverts the VSYNC output.
HOS	SOCR.4	HSYNC Output Selection bit. Setting this bit selects the VSYNC output, clearing it selects P3.5 SFR bit.
VOS	SOCR.5	VSYNC Output Selection bit. Setting this bit selects the VSYNC output, clearing it selects P3.3 SFR bit.

SOCR is a write only register. Its value after reset is 00h which enables P3.3 and P3.5 general purpose I/O pins.

Note: when packaging P2.X is selected, PWM0 to PWM7 are not available. Please refer to ordering information.

7.3. Controlled HSYNC and VSYNC Outputs

SOCR is used to configure P3.3 and P3.5 pins as buffered HSYNC and VSYNC outputs or as general purpose I/Os. When either HSYNC or VSYNC is selected, the output level can be respectively programmed as P3.4 or P3.2 input level (inverted or not), or as a low level if not enabled. Figure 12. shows the programmable HSYNC and VSYNC output block diagram.

SOCR is using TSC8051C1 Special Function Register address, E5h.

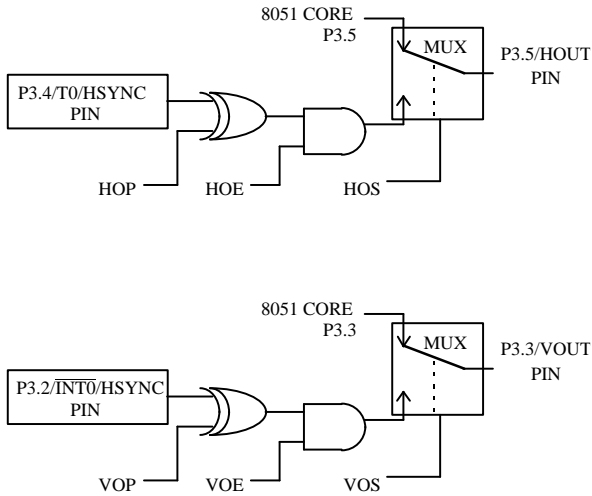

Figure 12. Buffered HSYNC and VSYNC block diagram

EICON: External Input Control Register

MSB		SFR E4h					LSB	
-	-	-	-	-	TOL	TOS	IOL	

Symbol	Position	Name and Function
IOL	EICON.0	$\overline{\text{INT0}}/\text{VSYNC}$ input Level bit. Setting this bit inverts $\overline{\text{INT0}}/\text{VSYNC}$ input signal. Clearing it allows standard use of $\overline{\text{INT0}}/\text{VSYNC}$ input.
TOS	EICON.1	T0/HSYNC input Selection bit. Setting this bit allows short pulse capture. Clearing it allows standard use of T0/HSYNC input.
TOL	EICON.2	T0/HSYNC input Level bit. Setting this bit allows positive pulse capture. Clearing it allows negative pulse capture.

EICON is a write only register. Its value after reset is 00h which allows standard $\overline{\text{INT0}}$ and T0 inputs feature.

EICON is using TSC8051C1 Special Function Register address, E4h.

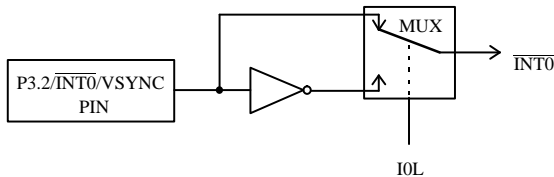

Figure 13. $\overline{\text{INT0}}/\text{VSYNC}$ input block diagram

7.4. HSYNC and VSYNC Inputs

EICON is used to control $\overline{\text{INT0}}/\text{VSYNC}$ input. Thus, an interrupt on either falling or rising edge and on either high or low level can be requested. Figure 13. shows the programmable $\overline{\text{INT0}}/\text{VSYNC}$ input block diagram.

EICON is also used to control T0/HSYNC input as short pulses input capture to be able to count them with timer 0. Pulse duration shorter than 1 clock period is rejected; depending on the position of the sampling point in the pulse, pulse duration longer than 1 clock period and shorter than 1.5 clock period may be rejected or accepted; and pulse duration longer than 1.5 clock period is accepted. Moreover selection of negative or positive pulses can be programmed.

Accepted pulse is lengthened up to 1 cycle period to be sampled by the 8051 core (one time per machine cycle: 12 clock periods), this implies that the maximum pulse frequency is unchanged and equal to $f_{\text{OSC}}/24$. Figure 14. shows the programmable T0/HSYNC input block diagram. The Digital Timer Delay samples T0/HSYNC pulses and rejects or lengthens them.

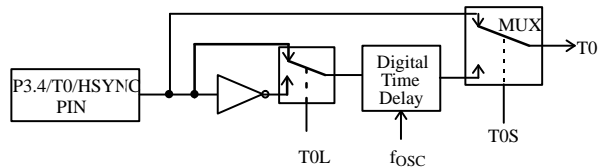

Figure 14. T0/HSYNC input block diagram

7.5. SIO1, I²C Serial I/O

SIO1 provides a serial interface that meets the I²C bus specification and supports the master transfer modes with multimaster capability from and to the I²C bus. The SIO1 logic handles bytes transfer autonomously. It also keeps track of serial transfers and a status register reflects the status of SIO1 and the I²C bus.

Figure 15. shows a typical use of I²C bus with SIO1, and Figure 16. shows a complete data transfer with SIO1.

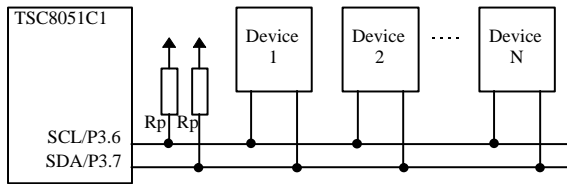

Figure 15. Typical I²C bus configuration

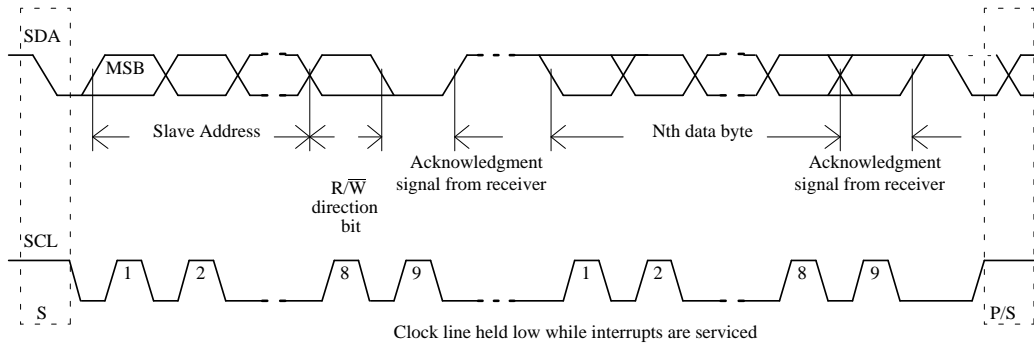

Figure 16. Complete data transfer on I²C bus

Three 8-bit special function registers are used to control SIO1: the control register (S1CON SFR), the status register (S1STA SFR) and the data register (S1DAT SFR).

S1CON is used to enable SIO1, to program the bit rate (see Table 6.), to acknowledge or not a received data, to send a start or a stop condition on the I²C bus, and to acknowledge a serial interrupt.

S1CON: Synchronous Serial Control Register

MSB		SFR D8h					LSB	
CR2	ENS1	STA	STO	SI	AA	CR1	CR0	

Symbol	Position	Name and Function
CR0	S1CON.0	Control Rate bit 0. See Table 6.
CR1	S1CON.1	Control Rate bit 1. See Table 6.
AA	S1CON.2	Assert Acknowledge flag. In receiver mode, setting this bit forces an acknowledge (low level on SDA). In receiver mode, clearing this bit forces a not acknowledge (high level on SDA). When in transmitter mode, this bit has no effect.
SI	S1CON.3	Synchronous Serial Interrupt flag. This bit is set by hardware when a serial interrupt is requested. This bit must be reset by software to acknowledge interrupt.
ST0	S1CON.4	Stop flag. Setting this bit causes a stop condition to be sent on bus.
STA	S1CON.5	Start flag. Setting this bit causes a start condition to be sent on bus.
ENS1	S1CON.6	Synchronous Serial Enable bit. Setting this bit enables the SIO1 controller.
CR2	S1CON.7	Control Rate bit 2. See Table 6.

S1CON is a read/write. Its value after reset is 00h which disables the I²C controller.

S1CON is using TSC8051C1 Special Function Register address, D8h.

Table 6. Serial Clock Rates

CR2	CR1	CR0	Bit frequency (kHz)		fosc divided by
			6MHz	12MHz	
0	0	0	23.5	47	256
0	0	1	27	53.5	224
0	1	0	31.25	62.5	192
0	1	1	37.5	75	160
1	0	0	6.25	12.5	960
1	0	1	50	100	120
1	1	0	100	–	60
1	1	1	0.25<62.5	0.5<62.5	Timer 1 overflow 96 x (256 – reload value) value: 0–254 in mode 2

S1STA contains a status code which reflects the status of SIO1 and the I²C bus. The three least significant bits are always zero. The five most significant bits contains the status code. There are 12 possible status code. When S1STA contains F8h, no relevant state information is available and no serial interrupt is requested. A valid status code is available in S1STA one machine cycle after SI is set by hardware and is still present one machine cycle after SI has been reset by software. Table 7. to Table 9. give the status for the operating modes and miscellaneous states.

S1STA: Synchronous Serial Status Register

MSB		SFR D9h					LSB	
SC4	SC3	SC2	SC1	SC0	0	0	0	

Symbol	Position	Name and Function
SC0	S1STA.3	Status Code bit 0.
SC1	S1STA.4	Status Code bit 1.
SC2	S1STA.5	Status Code bit 2.
SC3	S1STA.6	Status Code bit 3.
SC4	S1STA.7	Status Code bit 4.

S1STA is a read only register. Its value after reset is F8h.

S1STA is using TSC8051C1 Special Function Register address, D9h.

Table 7. Status for master transmitter mode.

Status code	Status of I ² C bus and SIO1 hardware
08h	A START condition has been transmitted.
10h	A repeated START condition has been transmitted
18h	SLA+W has been transmitted; ACK has been received.
20h	SLA+W has been transmitted; NOT ACK has been received.
28h	Data byte has been transmitted; ACK has been received.
30h	Data byte has been transmitted; NOT ACK has been received.
38h	Arbitration lost in SLA+R/W or data bytes.

Table 8. Status for master receiver mode

Status code	Status of I ² C bus and SIO1 hardware
08h	A START condition has been transmitted.
10h	A repeated START condition has been transmitted.
38h	Arbitration lost in NOT ACK bit
40h	SLA+R has been transmitted; ACK has been received.
48h	SLA+R has been transmitted; NOT ACK has been received.
50h	Data byte has been received; ACK has been received.
58h	Data byte has been received; NOT ACK has been received.

Table 9. Status for miscellaneous states

Status code	Status of I ² C bus and SIO1 hardware
00h	Bus error.
F8h	No relevant state information available.

S1DAT contains a byte of serial data to be transmitted or a byte which has just been received. It is addressable while it is not in process of shifting a byte. This occurs when SIO1 is in a defined state and the serial interrupt flag is set. Data in S1DAT remains stable as long as SI is set. While data is being shifted out, data on the bus is simultaneously shifted in; S1DAT always contains the last byte present on the bus.

S1DAT: Synchronous Serial Data Register

MSB		SFR DAh					LSB
SD7	SD6	SD5	SD4	SD3	SD2	SD1	SD0

Symbol	Position	Name and Function
SD0	S1DAT.0	Address bit 0 (R/W) or Data bit 0.
SDX	S1DAT.X	Address bit X or Data bit X.

S1DAT is a read/write register. Its value after reset is 00h.

S1DAT is using TSC8051C1 Special Function Register address, DAh.

When SIO1 is enabled, P3.6 and P3.7 must be set to 1 to avoid low level asserting on SCL or SDA lines.

When SIO1 is used, external data memory access is not available.

8. Electrical Characteristics

Absolute Maximum Ratings⁽¹⁾

Operating Temperature:	Voltage on VCC to VSS	-0.5V to +7V	
Commercial	0°C to 70°C	Voltage on Any Pin to VSS	-0.5V to VCC + 0.5V
Industrial	-40°C to +85°C	Power Dissipation	1W ⁽²⁾
Storage Temperature	-65°C to +150°C		

Notice:

1. Stresses above those listed under “Absolute Maximum Ratings” may cause permanent damage to the device. This is a stress rating only and functional operation of the device at these or any other conditions above those indicated in the operational sections of this specification is not implied. Exposure to absolute maximum rating conditions for extended periods may affect device reliability.

2. This value is based on the maximum allowable die temperature and the thermal resistance of the package.

8.1. DC Characteristics

T_A = 0°C to +70°C; VSS = 0V; VCC = 5V ± 10%; F = 0 to 16MHz.

T_A = -40°C to +85°C; VSS = 0V; VCC = 5V ± 10%; F = 0 to 16MHz.

Symbol	Parameter	Min	Typ	Max	Unit	Test Conditions
Inputs						
VIL	Input Low Voltage, except SCL, SDA	-0.5		0.2 Vcc - 0.1	V	
VIL1	Input Low Voltage, SCL, SDA ⁽⁵⁾	-0.5		0.3 Vcc	V	
VIH	Input High Voltage except XTAL1, RST, SCL, SDA	0.2 Vcc + 0.9		Vcc + 0.5	V	
VIH1	Input High Voltage, XTAL1, RST	0.7 Vcc		Vcc + 0.5	V	
VIH2	Input High Voltage, SCL, SDA ⁽⁵⁾	0.7 Vcc		Vcc + 0.5	V	
IIL	Logical 0 Input Current ports 1, 2 and 3			-50	µA	Vin = 0.45V
ILI	Input Leakage Current			±10	µA	0.45 < Vin < Vcc
ITL	Logical 1 to 0 Transition Current, ports 1, 2, 3			-650	µA	Vin = 2.0V
Outputs						
VOL	Output Low Voltage, ports 1, 2, 3, SCL, SDA, PWM0-7 ⁽⁷⁾			0.3 0.45 1.0	V V V	IOL = 100µA ⁽⁴⁾ IOL = 1.6mA ⁽⁴⁾ IOL = 3.5mA ⁽⁴⁾
VOL1	Output Low Voltage, port 0, ALE, $\overline{\text{PSEN}}$ ⁽⁷⁾			0.3 0.45 1.0	V V V	IOL = 200µA ⁽⁴⁾ IOL = 3.2mA ⁽⁴⁾ IOL = 7.0mA ⁽⁴⁾
VOH	Output High Voltage, ports 1, 2, 3, SCL, SDA	Vcc - 0.3 Vcc - 0.7 Vcc - 1.5			V V V	IOH = -10µA IOH = -30µA IOH = -60µA Vcc = 5V ± 10%
VOH1	Output High Voltage, port 0, ALE, $\overline{\text{PSEN}}$	Vcc - 0.3 Vcc - 0.7 Vcc - 1.5			V V V	IOH = -200µA IOH = -3.2mA IOH = -7.0mA Vcc = 5V ± 10%
RRST	RST Pulldown Resistor	50	90 ⁽⁶⁾	200	kΩ	

Symbol	Parameter	Min	Typ	Max	Unit	Test Conditions
CIO	Capacitance of I/O Buffer			10	pF	$f_c = 1\text{MHz}$, $T_A = 25^\circ\text{C}$
ICC	Power Supply Current ⁽⁸⁾ Active Mode 12MHz Idle Mode 12MHz		8.5 ⁽⁶⁾ 2.6 ⁽⁶⁾	17 8	mA mA	$V_{CC} = 5.5\text{V}^{(1)}$ $V_{CC} = 5.5\text{V}^{(2)}$
IPD	Power Down Current		5 ⁽⁶⁾	30	μA	$V_{CC} = 2.0\text{V to } 5.5\text{V}^{(3)}$

Notes for DC Electrical Characteristics

1. ICC is measured with all output pins disconnected; XTAL1 driven with TCLCH, TCHCL = 5 ns (see Figure 20.), $V_{IL} = V_{SS} + 0.5\text{V}$, $V_{IH} = V_{CC} - 0.5\text{V}$; XTAL2 N.C.; EA = RST = Port 0 = VCC. ICC would be slightly higher if a crystal oscillator used (see Figure 17.).
2. Idle ICC is measured with all output pins disconnected; XTAL1 driven with TCLCH, TCHCL = 5ns, $V_{IL} = V_{SS} + 0.5\text{V}$, $V_{IH} = V_{CC} - 0.5\text{V}$; XTAL2 N.C.; Port 0 = VCC; EA = RST = VSS (see Figure 19.).
3. Power Down ICC is measured with all output pins disconnected; $\overline{\text{EA}} = \text{PORT } 0 = V_{CC}$; XTAL2 NC.; RST = VSS (see Figure 19.).
4. Capacitance loading on Ports 0 and 2 may cause spurious noise pulses to be superimposed on the VOLs of ALE and Ports 1 and 3. The noise is due to external bus capacitance discharging into the Port 0 and Port 2 pins when these pins make 1 to 0 transitions during bus operation. In the worst cases (capacitive loading 100pF), the noise pulse on the ALE line may exceed 0.45V with maxi VOL peak 0.6V. A Schmitt Trigger use is not necessary.
5. The input threshold voltage of SCL and SDA (SIO1) meets the I²C specification, so an input voltage below 0.3·VCC will be recognised as a logic 0 while an input voltage above 0.7·VCC will be recognised as a logic 1.
6. Typicals are based on a limited number of samples and are not guaranteed. The values listed are at room temperature and 5V.
7. Under steady state (non-transient) conditions, IOL must be externally limited as follows:

Maximum IOL per port pin:	10 mA
Maximum IOL per 8-bit port:	
Port 0:	26 mA
Ports 1, 2 and 3:	15 mA
Maximum total IOL for all output pins:	71 mA

 If IOL exceeds the test condition, VOL may exceed the related specification. Pins are not guaranteed to sink current greater than the listed test conditions.
8. For other values, please contact your sales office.

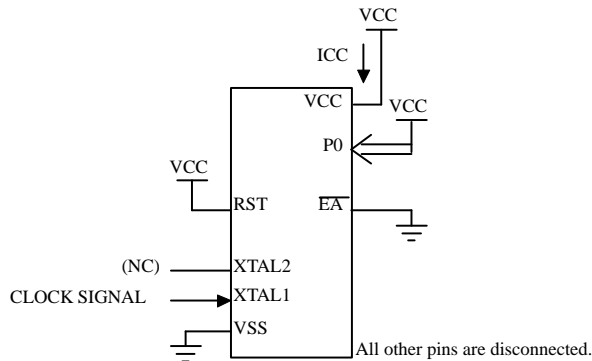

Figure 17. ICC Test Condition, Active Mode.

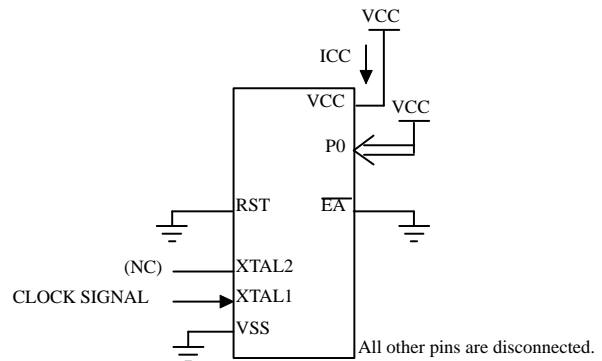

Figure 18. ICC Test Condition, Idle Mode.

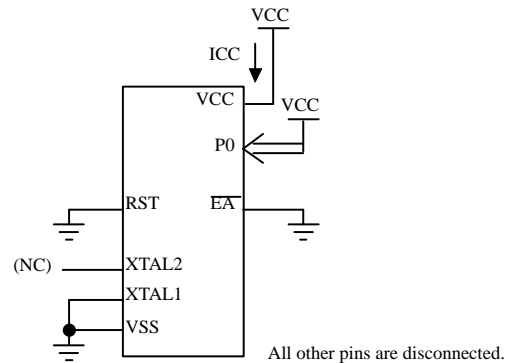

Figure 19. ICC Test Condition, Power Down Mode.

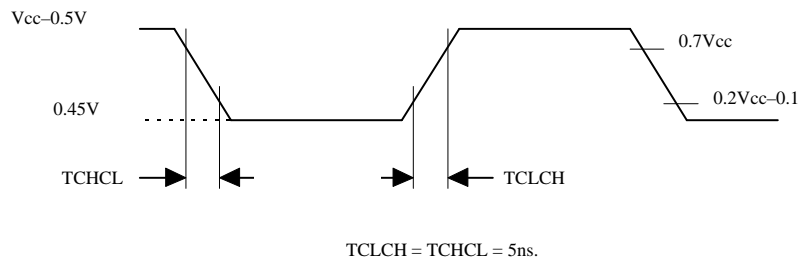

Figure 20. Clock Signal Waveform for ICC Tests in Active and Idle Modes.

8.2. Explanation Of The AC Symbol

Each timing symbol has 5 characters. The first character is always a “T” (stands for time). The other characters, depending on their positions, stand for the name of a signal or the logical status of that signal. The following is a list of all the characters and what they stand for.

Example:

TAVLL = Time for Address Valid to ALE low.

TLLPL = Time for ALE low to PSEN low.

A: Address.	Q: Output data.
C: Clock.	R: READ signal.
D: Input data.	T: Time.
H: Logic level HIGH.	V: Valid.
I: Instruction (Program memory contents).	W: WRITE signal.
L: Logic level LOW, or ALE.	X: No longer a valid logic level.
P: PSEN.	Z: Float.

8.3. AC Parameters

$T_A = 0$ to $+70^\circ\text{C}$; $V_{SS} = 0\text{V}$ $V_{CC} = 5\text{V} \pm 10\%$; 0 to 12MHz

$T_A = -40^\circ\text{C}$ to $+85^\circ\text{C}$; $V_{SS} = 0\text{V}$; $V_{CC} = 5\text{V} \pm 10\%$; $F = 0$ to 12MHz.

(Load Capacitance for PORT 0, ALE and PSEN = 100pf; Load Capacitance for all other outputs = 80 pF.)

8.4. External Program Memory Characteristics

Symbol	Parameter	0 to 12MHz		Units
		Min	Max	
TLHLL	ALE pulse width	2TCLCL - 40		ns
TAVLL	Address Valid to ALE	TCLCL - 40		ns
TLLAX	Address Hold After ALE	TCLCL - 30		ns
TLLIV	ALE to Valid Instruction In		4TCLCL - 100	ns
TLLPL	ALE to PSEN	TCLCL - 30		ns
TPLPH	PSEN Pulse Width	3TCLCL - 45		ns
TPLIV	PSEN to Valid Instruction In		3TCLCL - 105	ns
TPXIX	Input Instruction Hold After PSEN	0		ns

Symbol	Parameter	0 to 12MHz		Units
		Min	Max	
TPXIZ	Input Instruction Float After PSEN		TCLCL - 25	ns
TPXAV	PSEN to Address Valid	TCLCL - 8		ns
TAVIV	Address to Valid Instruction In		5TCLCL - 105	ns
TPLAZ	PSEN Low to Address Float		10	ns

8.5. External Program Memory Read Cycle

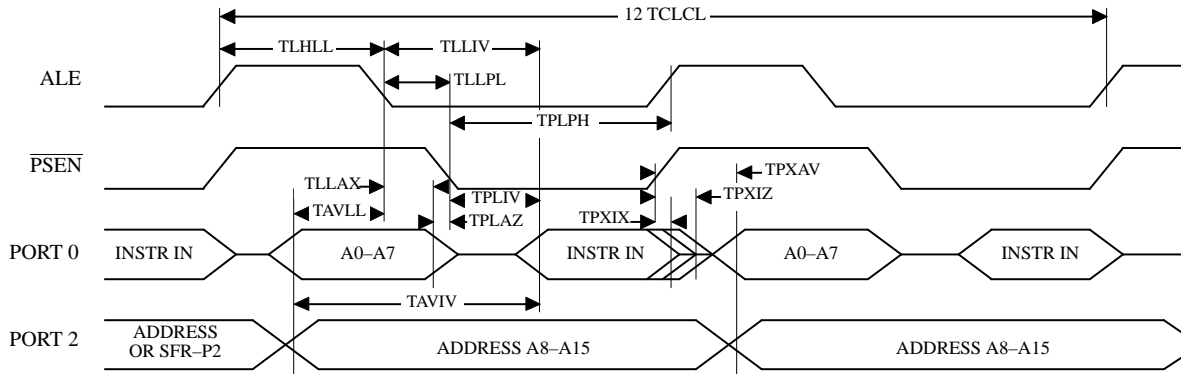

8.6. External Data Memory Characteristics

Symbol	Parameter	0 to 12MHz		Units
		Min	Max	
TRLRH	RD Pulse Width	6TCLCL-100		ns
TWLWH	WR Pulse Width	6TCLCL-100		ns
TRLDV	RD to Valid Data In		5TCLCL-165	ns
TRHDX	Data Hold After RD	0		ns
TRHDZ	Data Float After RD		2TCLCL-60	ns
TLLDV	ALE to Valid Data In		8TCLCL-150	ns
TAVDV	Address to Valid Data In		9TCLCL-165	ns
TLLWL	ALE to WR or RD	3TCLCL-50	3TCLCL+50	ns
TAVWL	Address to WR or RD	4TCLCL-130		ns
TQVWX	Data Valid to WR Transition	TCLCL-50		ns
TQVWH	Data set-up to WR High	7TCLCL-150		ns
TWHQX	Data Hold After WR	TCLCL-50		ns
TRLAZ	RD Low to Address Float		0	ns
TWHLH	RD or WR High to ALE high	TCLCL-40	TCLCL+40	ns

8.7. External Data Memory Write Cycle

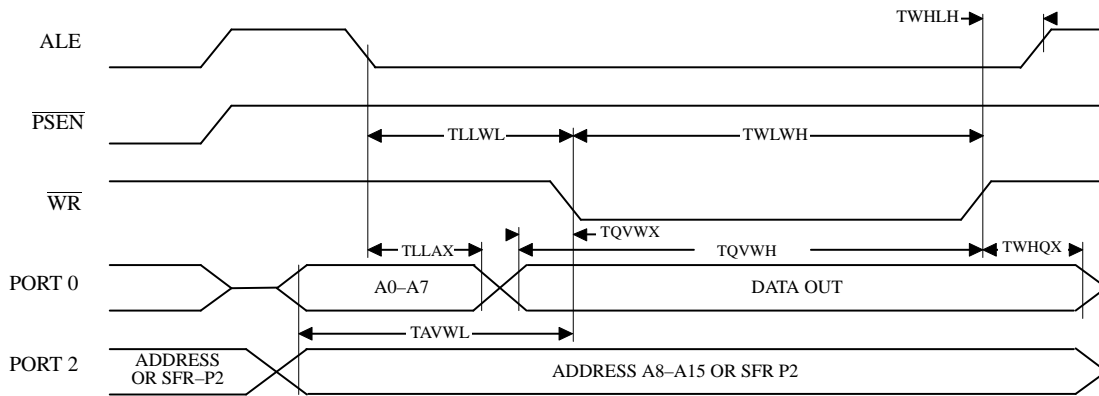

8.8. External Data Memory Read Cycle

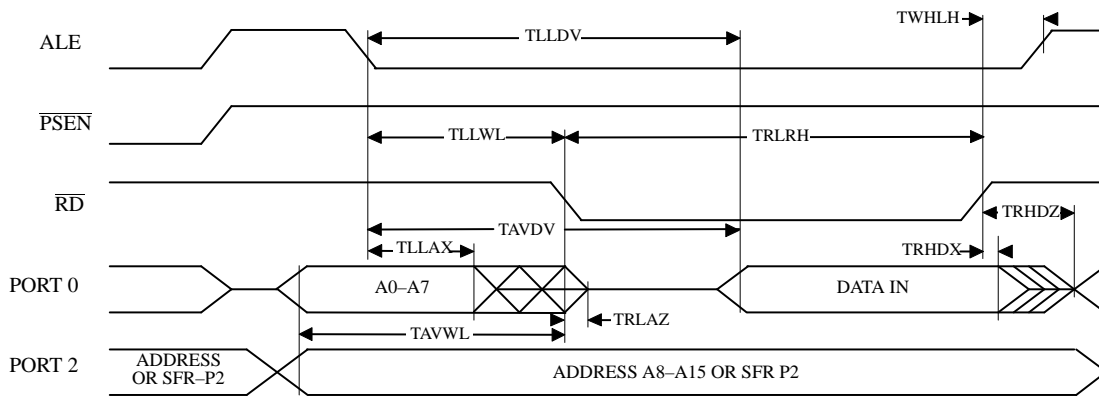

8.9. Serial Port Timing—Shift Register Mode

Symbol	Parameter	0 to 12MHz		Units
		Min	Max	
TXLXL	Serial port clock cycle time	12TCLCL		ns
TQVHX	Output data set-up to clock rising edge	10TCLCL-133		ns
TXHQX	Output data hold after clock rising edge	2TCLCL-117		ns
TXHDX	Input data hold after clock rising edge	0		ns
TXHDV	Clock rising edge to input data valid		10TCLCL-133	ns

8.10. Shift Register Timing Waveforms

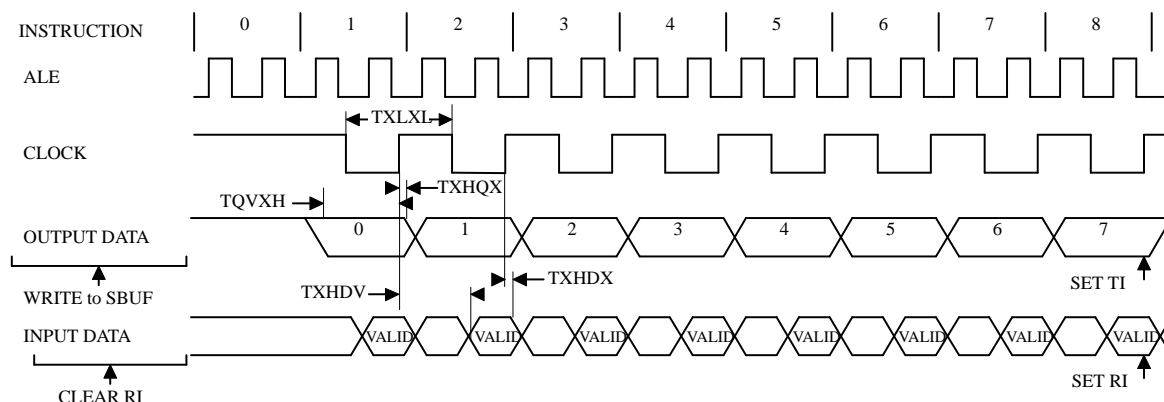

8.11. SIO1 (I²C) Interface Timing

Symbol	Parameter	Input	Output
THD; STA	Start condition hold time	$\geq 14 T_{CLCL}$	$> 4.0\mu s^{(1)}$
TLOW	SCL low time	$\geq 16 T_{CLCL}$	$> 4.7\mu s^{(1)}$
THIGH	SCL high time	$\geq 14 T_{CLCL}$	$> 4.0\mu s^{(1)}$
TRC	SCL rise time	$\leq 1\mu s$	– ⁽²⁾
TFC	SCL fall time	$\leq 0.3\mu s$	$< 0.3\mu s^{(3)}$
TSU; DAT1	Data set-up time	$\geq 250ns$	$> 20 T_{CLCL} - TRD$
TSU; DAT2	SDA set-up time (before repeated START condition)	$\geq 250ns$	$> 1\mu s^{(1)}$
TSU; DAT3	SDA set-up time (before STOP condition)	$\geq 250ns$	$> 8 T_{CLCL}$
THD; DAT	Data hold time	$\geq 0ns$	$> 8 T_{CLCL} - T_{FC}$
TSU; STA	Repeated START set-up time	$\geq 14 T_{CLCL}$	$> 4.7\mu s^{(1)}$
TSU; STO	STOP condition set-up time	$\geq 14 T_{CLCL}$	$> 4.0\mu s^{(1)}$
TBUF	Bus free time	$\geq 14 T_{CLCL}$	$> 4.7\mu s^{(1)}$
TRD	SDA rise time	$\leq 1\mu s$	– ⁽²⁾
TFD	SDA fall time	$\leq 0.3\mu s$	$< 0.3\mu s^{(3)}$

Notes:

- At 100 kbit/s. At other bit-rates this value is inversely proportional to the bit-rate of 100 kbit/s.
- Determined by the external bus-line capacitance and the external bus-line pull-up resistor, this must be $< 1\mu s$.
- Spikes on the SDA and SCL lines with a duration of less than 3 T_{CLCL} will be filtered out. Maximum capacitance on bus-lines SDA and SCL = 400pF.

8.12. SIO1 (I²C) Timing Waveforms

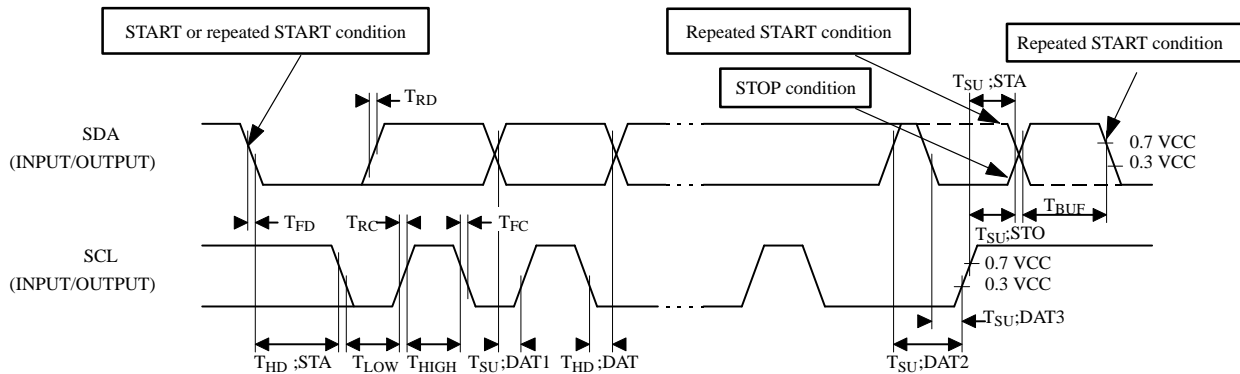

8.13. External Clock Drive Characteristics (XTAL1)

Symbol	Parameter	Min	Max	Units
TCLCL	Oscillator Period	83.3		ns
TCHCX	High Time	5		ns
TCLCX	Low Time	5		ns
TCLCH	Rise Time		5	ns
TCHCL	Fall Time		5	ns

8.14. External Clock Drive Waveforms

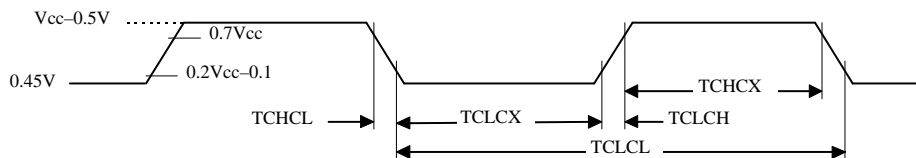

8.15. AC Testing Input/Output Waveforms

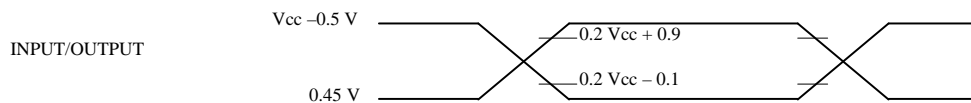

AC inputs during testing are driven at $V_{cc} - 0.5$ for a logic “1” and 0.45V for a logic “0”. Timing measurement are made at V_{IH} min for a logic “1” and V_{IL} max for a logic “0”.

8.16. Float Waveforms

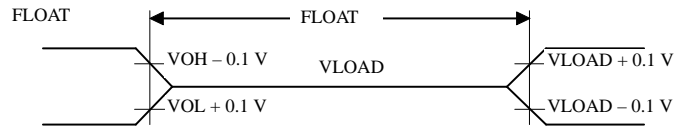

For timing purposes as port pin is no longer floating when a 100 mV change from load voltage occurs and begins to float when a 100 mV change from the loaded V_{OH}/V_{OL} level occurs. $I_{OL}/I_{OH} \geq \pm 20\text{mA}$.

8.17. Clock Waveform

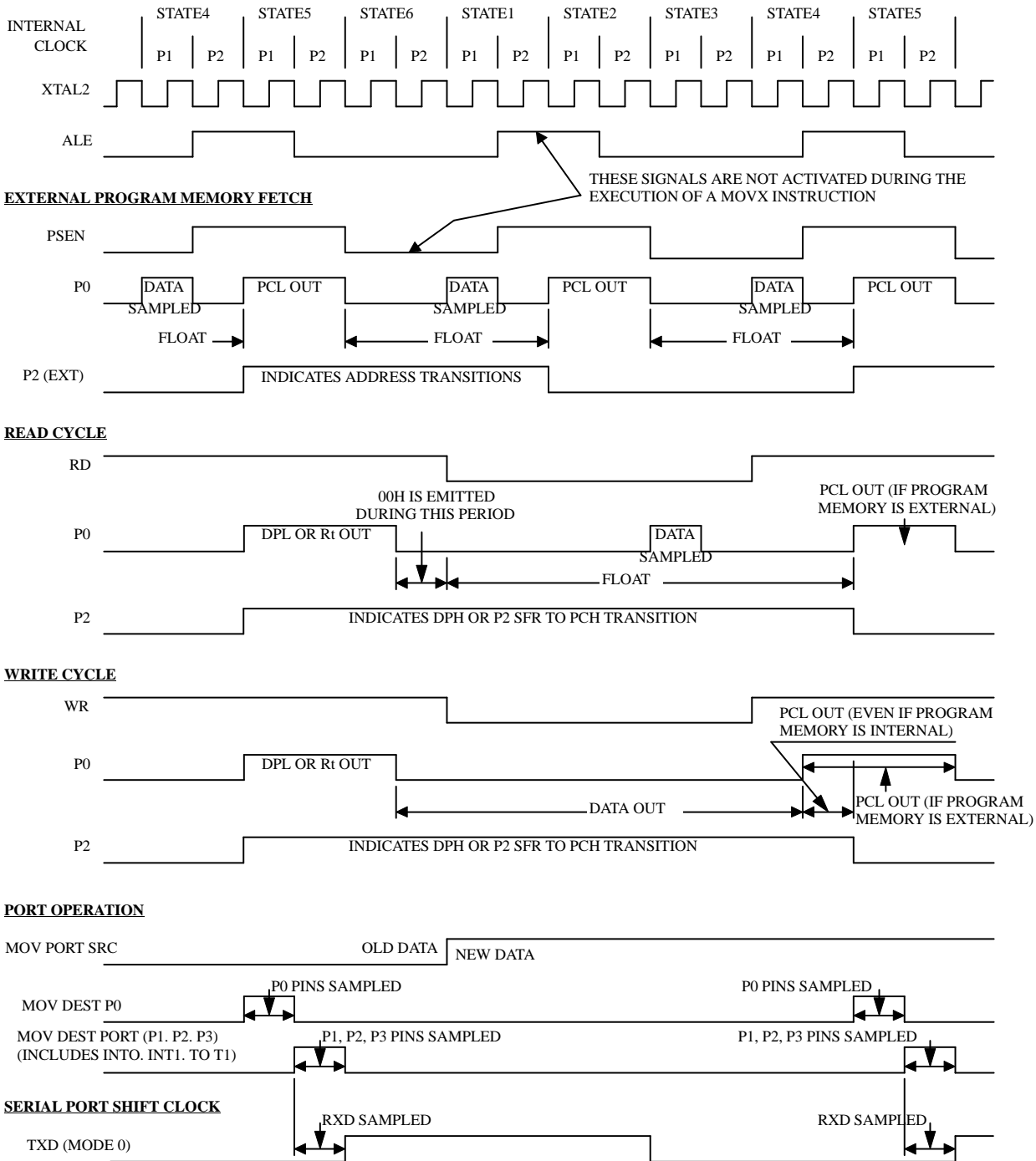

This diagram indicates when signals are clocked internally. The time it takes the signals to propagate to the pins, however, ranges from 25 to 125ns. This propagation delay is dependent on variables such as temperature and pin loading. Propagation also varies

from output to output and component. Typically though ($T_A=25^\circ\text{C}$ fully loaded) $\overline{\text{RD}}$ and $\overline{\text{WR}}$ propagation delays are approximately 50ns. The other signals are typically 85ns. Propagation delays are incorporated in the AC specifications.

9. Ordering Information

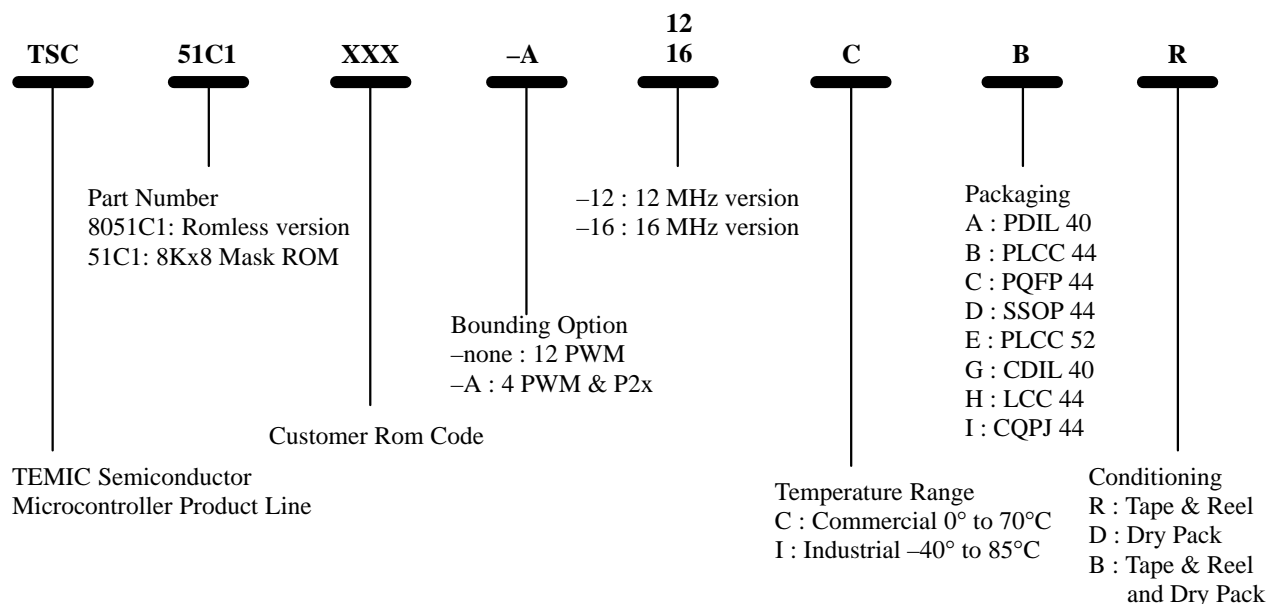

Examples

Part Number	Description
TSC51C1XXX-12CA	Mask ROM XXX, 12 MHz, PDIL 40, 0 to 70°C
TSC8051C1-16CER	ROMless, 16 MHz, PLCC 52, 0 to 70°C, Tape and Reel

Development Tools

Reference	Description
ANM059	Application Note: "How to recognize video mode and generate free running synchronization signals using TSC8051C1/C2 Microcontroller"
IM-80C51-RB-400-40	Emulator Base
PC-TSC8051C1-RB-16	Probe card for TSC8051C1. These products are released by Metalink. Please consult the local tools distributor or your sales office.

Product Marking :

TEMIC Customer P/N Temic P/N © Intel 80, 82 YYWW Lot Number
