

UTC UA9406 LINEAR INTEGRATED CIRCUIT

2-PHASE HALF-WAVE MOTOR PREDRIVER

DESCRIPTION

The UTC UA9406 is a 2-phase, half-wave motor predriver suited for fan motors.

FEATURES

- *Lock detection and rotational speed sensing mechanisms are built in.
- *Compact 8-pin SOP package reduces the number of external components required.
- *Automatic restart when the motor lock is undone.
- *Hall inputs have a hysteresis.

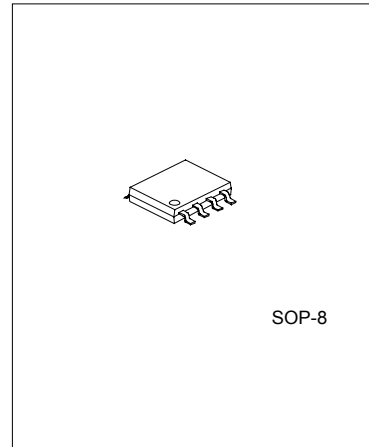

BLOCK DIAGRAM

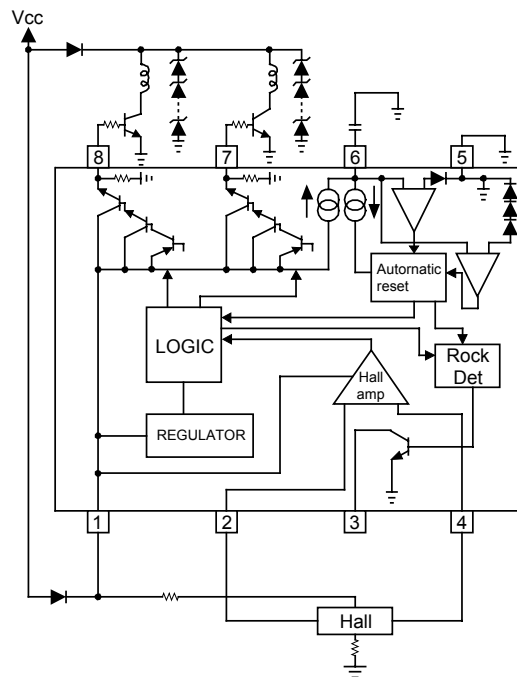

UTC UA9406 LINEAR INTEGRATED CIRCUIT

ABSOLUTE MAXIMUM RATINGS

PARAMETER	SYMBOL	RATINGS	UNIT
Applied voltage	V _{cc}	30	V
Power dissipation	P _d	550*	mW
Operating Temperature	T _{opr}	-30 ~ +75	°C
Storage Temperature	T _{stg}	-55 ~ +125	°C
Output current	I _o Max.	70	mA

* Reduced by 5.5mW for each increase in T_a of 1°C over 25°C
When mounted on a glass epoxy board (50×50×1.6mm)

OPERATING POWER SUPPLY VOLTAGE (T_a=25°C)

PARAMETER	SYMBOL	TEST CONDITIONS	MIN	TYP	MAX	UNIT
Applied voltage	V _{cc}	Operate within the allowable power Dissipation for -30°C<T _a <75°C	4		28	V
Input voltage*	V _{BH}		1.0		V _{cc} -0.5	V

*Input voltage range includes the amplitude of signal

ELECTRICAL CHARACTERISTICS (Unless otherwise noted, T_a=25°C, V_{cc}=12V)

PARAMETER	SYMBOL	TEST CONDITIONS	MIN	TYP	MAX	UNIT
Supply current	I _{cc}	When output is OFF		3.2	5.0	mA
Hall amplifier input hysteresis (+)	V _{hys} ⁺	Pin2 voltage with respect to pin4 voltage, V _B =6V	3		15	mV
Hall amplifier input hysteresis (-)	V _{hys} ⁻	Pin2 voltage with respect to pin4 voltage, V _B =6V	-3		-15	mV
Pin6 charge current	I _{6c}	V _{6pin} =1.5V	2.0	3.45	5.25	μA
Pin6 discharge current	I _{6d}	V _{6pin} =1.5V	0.35	0.80	1.45	μA
Pin6 charge/discharge ratio	r _{cd}	I _{6c} /I _{6d}	3	4.5	8	
Pin6 clamp voltage	V _{6CL}		2.2	2.6	3.0	V
Pin6 comparator voltage	V _{6cp}		0.4	0.6	0.8	V
Pin7 Output high level voltage	V _{7H}	I _o =10mA	10	10.5		V
Pin8 Output high level voltage	V _{8H}	I _o =10mA	10	10.5		V
Pin3 Output low level voltage	V _{3L}	I _{3L} =5.0mA			0.5	V
Pin3 current capacity	I ₃	V _{3L} =2.0V	8.0			mA

UTC UA9406 LINEAR INTEGRATED CIRCUIT

LOCK DETECTION

The automatic restart circuit detects a motor lock condition and automatically turns off the output current. When the lock condition is cleared, the IC automatically restarts and allow the motor to run.

In the UTC UA9406, automatic restart is performed in the following manner. A motor lock condition is detected when the Hall signal stops switching. The output is ON when pin 6 is being charged, and OFF when pin 6 is being discharged. Pin 3 is ON during normal operation, and OFF when the motor is locked. Pin 3 is an open collector output.

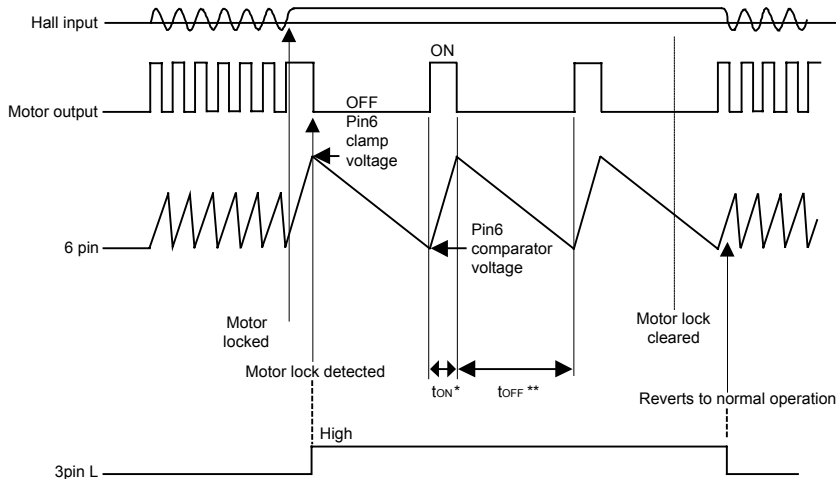

Fig.1

Output ON time (t_{ON}) and OFF time (t_{OFF}) determined by the pin6 capacitor where

$$t_{ON} = \frac{C \cdot (V_{6CL} - V_{6CP})}{I_{6C}} \text{ (sec)}$$

$$t_{OFF} = \frac{C \cdot (V_{6CL} - V_{6CP})}{I_{6d}} \text{ (sec)}$$

C is the capacitance of the pin-6 external capacitor
 V_{6CL} is the pin6 clamp voltage
 V_{6CP} is the pin6 comparator voltage
 I_{6C} is the pin6 charge current
 I_{6d} is the pin6 discharge current

OPERATION NOTES

- (1) The lock detection output pin (pin 3) may maintain HIGH level for a few hundred milliseconds when the power is turned on.

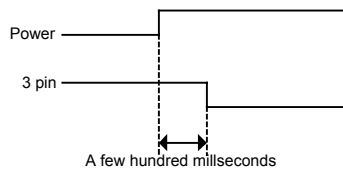

Fig.2

UTC UA9406 LINEAR INTEGRATED CIRCUIT

(2) Allowable power dissipation

The allowable power dissipation is plotted against ambient temperature in Fig. 3.

(3) Power dissipation

Power consumed in the IC can be calculated from the following equation:

$$P_c = P_{c1} + P_{c2} + P_{c3}$$

(1) P_{c1} is power consumed by the circuit current.

$$P_{c1} = V_{cc} \times I_{cc}$$

(2) P_{c2} is the output current consumption.

$$P_{c2} = (V_{cc} \times V_{OH}) \times I_o$$

V_{OH} is the HIGH level voltage of pins 7 and 8. Power dissipation can be reduced by raising the hfe-rank of the external output transistor and thereby reducing the I_o value.

(3) P_{c3} is power consumed by pin 3.

$$P_{c3} = V_{3L} \times I_3$$

Where V_{3L} is the pin-3 LOW level voltage and I_3 is the pin-3 current. Make sure that your application does not exceed the allowable power dissipation of the IC.

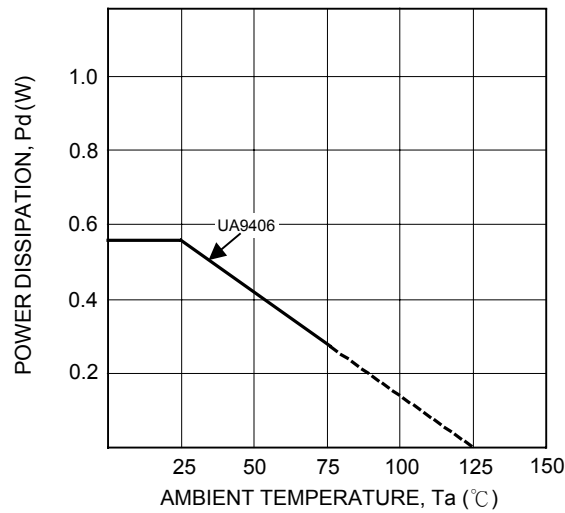
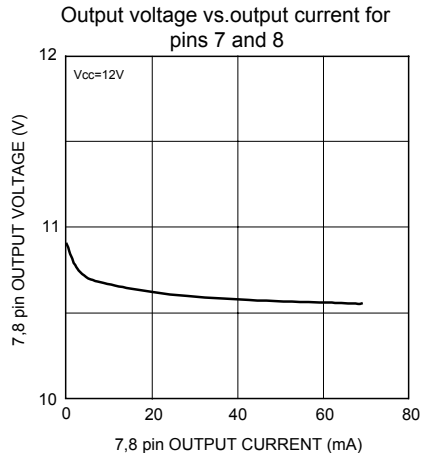
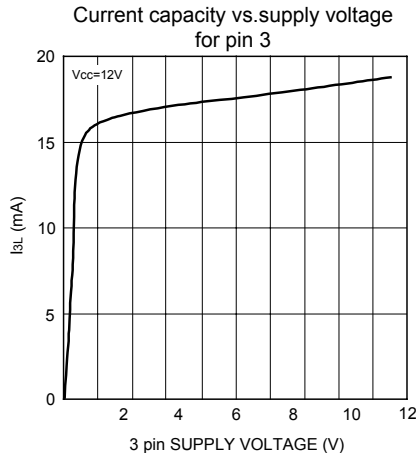

Fig.3

UTC UA9406 LINEAR INTEGRATED CIRCUIT

ELECTRICAL CHARACTERISTIC CURVES



UTC assumes no responsibility for equipment failures that result from using products at values that exceed, even momentarily, rated values (such as maximum ratings, operating condition ranges, or other parameters) listed in products specifications of any and all UTC products described or contained herein. UTC products are not designed for use in life support appliances, devices or systems where malfunction of these products can be reasonably expected to result in personal injury. Reproduction in whole or in part is prohibited without the prior written consent of the copyright owner. The information presented in this document does not form part of any quotation or contract, is believed to be accurate and reliable and may be changed without notice.