

288/300 OUTPUT TFT-LCD SOURCE DRIVER

DESCRIPTION

The μ PD16780 is a source driver for TFT-LCDs. The μ PD16780 corresponds only to LCD of Stripe array color filter. The μ PD16780 is constitute a shift register which generates the sampling time, and a sample-and-hold circuit which samples the analog voltage. There are two sample-and-hold circuits which perform sampling holding alternately.

The application with high free degree is possible from driver operation system to LCD-TV because a high picture quality is realized.

FEATURES

- 5.0 V Drive (Dynamic range 4.6 V_{P-P}, V_{DD2} = 5.0 V)
- 288/300 Output channel
- f_{MAX.} = 20 MHz (V_{DD1} = 3.0 V)
- Corresponds only to LCD of Stripe array color filter
- Two on-chip sample-and-hold circuits
- Small output deviation between pins (deviation between chip pins: ± 20 mV MAX.)
- Switch between right and left shift using the R,/L pin

ORDERING INFORMATION

Part Number	Package
μ PD16780N-xxx	TCP (TAB package)

Remark The TCP's external shape is custom-order item. Users are requested to consult with a NEC sales representative.

The information in this document is subject to change without notice. Before using this document, please confirm that this is the latest version.
 Not all devices/types available in every country. Please check with local NEC representative for availability and additional information.

1. BLOCK DIAGRAM

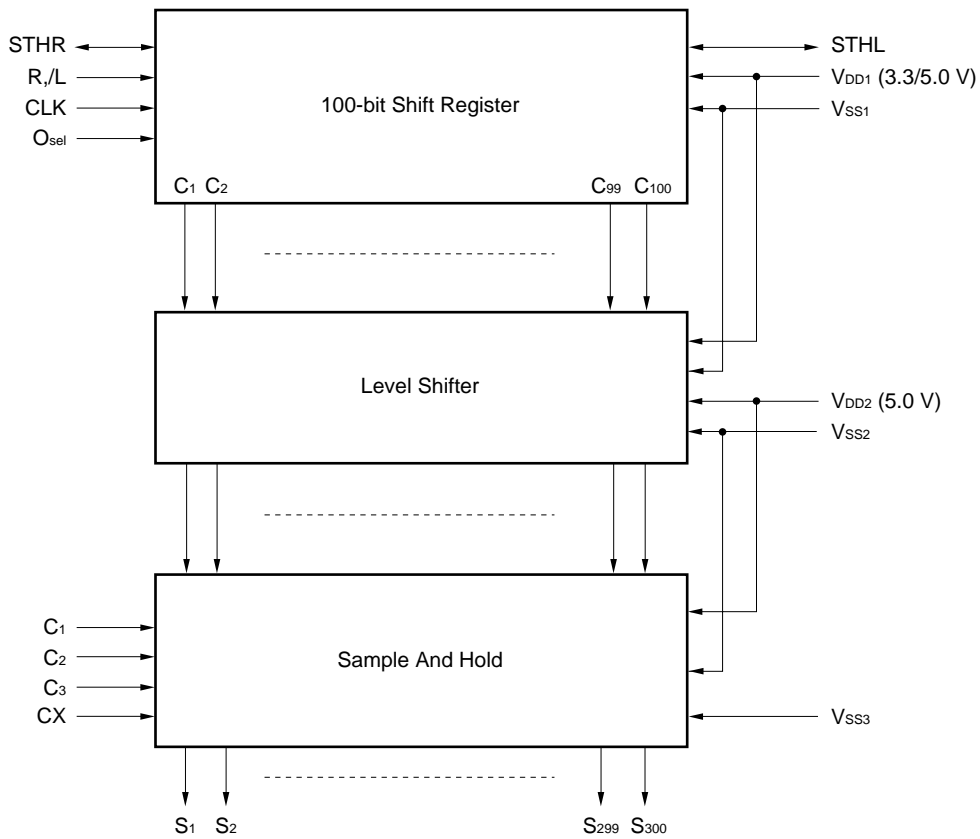

Remark /xxx indicates active low signal.

2. SAMPLE-AND HOLD CIRCUIT AND OUTPUT CIRCUIT

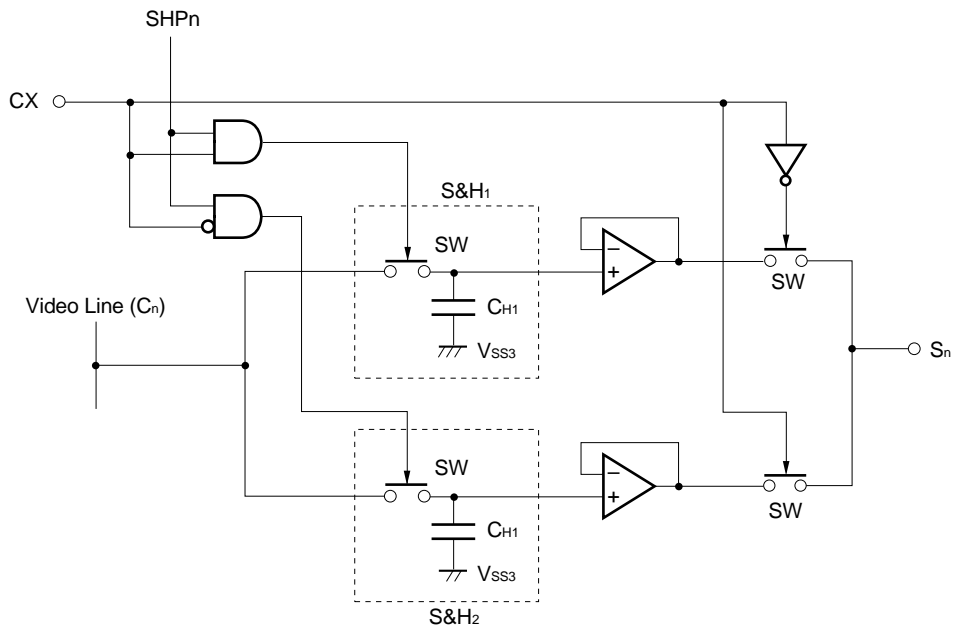

3. PIN CONFIGURATION (μ PD16780N-xxx)

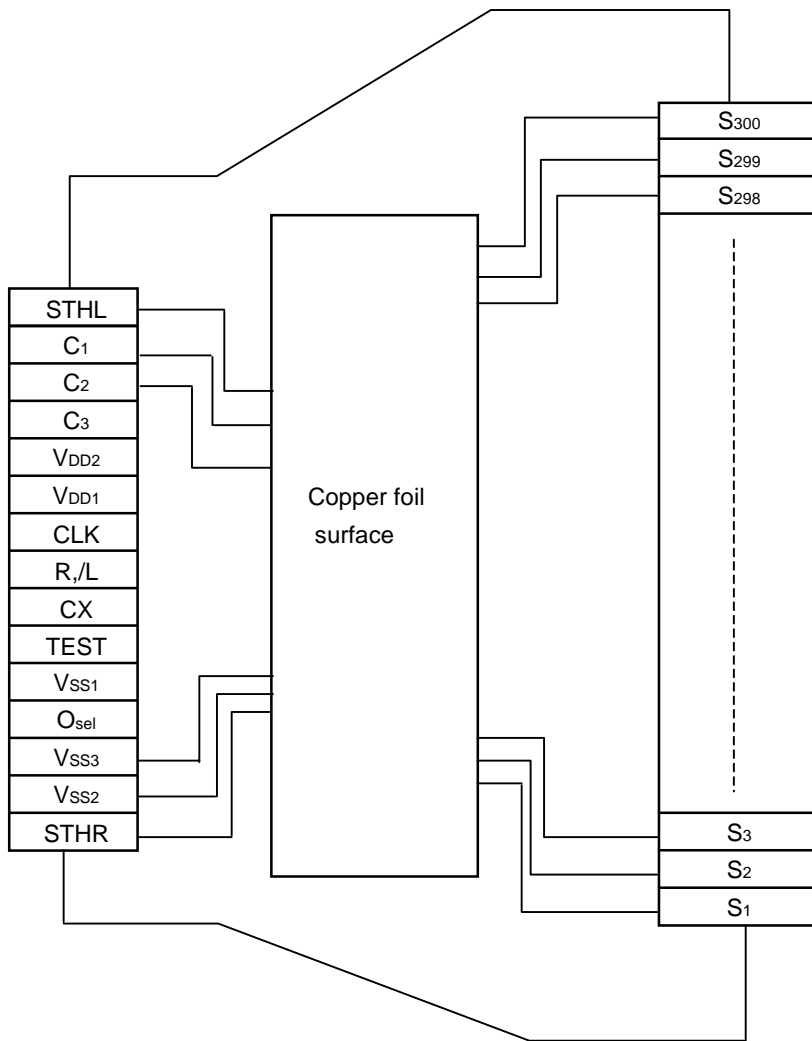

Remark This figure does not specify the TCP package.

4. PIN FUNCTIONS

Pin Symbol	Pin Name	Description
C ₁ ,C ₂ ,C ₃	Video signal input	These pins are input video signals R,G, and B.
S ₁ -S ₃₀₀	Video signal input	These pins are output video signals, which have been sampled and hold. C ₁ : S _{3n-2} (n = 1, 2,96/100) C ₂ : S _{3n-1} C ₃ : S _{3n}
STHR, STHL	Cascade I/O	These pins are inputs/outputs for the start pulse for sample and hold timing. High level of STHR/STHL is read at rising edge of CLK and start sampling video signal. STHR serves as the input pin and STHL serves as output pin for the right shift. For left shift, STHL serves as the input pins and STHR serves as the output pin.
★ R, _/ L	Shift direction switching input	The shift directions of the shift registers are as follows. R, _/ L = H: STHR input, S ₁ → S ₃₀₀ , STHL output. R, _/ L = L: STHL input, S ₃₀₀ → S ₁ , STHR output.
O _{sel}	Selection of Number of outputs switching input	Selects number of outputs. O _{sel} = L: 288 output mode O _{sel} = H: 300 output mode Output pins S ₁₄₅ through S ₁₅₆ are invalid in 288 output mode. The signal which is with S ₁₅₇ to S ₁₆₈ (R, _/ L = H) or S ₁₃₃ to S ₁₄₄ (R, _/ L = L) is output identically.
CLK	Shift clock input	The start pulse is read at rising edge of CLK. The sampling pulse SHP _n is generated at rising edge of CLK. μ PD16780 corresponds only to LCD of Stripe array color filter and only simultaneous sampling. For details, refer to 6. TIMING CHART .
CX	Hold capacitance control input	Two Sample & hold circuits are switched. CX = H S&H1: Sampling, S&H2: Output CX = L S&H1: Output, S&H2: Sampling
TEST	Test pin	Fix this pin to the L level.
V _{DD1}	Logic power supply	3.3 V ± 0.3 V, or 5.0 V ± 0.5 V
V _{DD2}	Driver power supply	5.0 V ± 0.5 V
V _{SS1}	Logic ground	Grounding
V _{SS2}	Driver ground	Grounding
V _{SS3}	Sample & hold ground	It is ground of Sample & hold capacitance. Supply this terminal with the stable GND.

- Cautions**
1. To prevent latch-up-breakdown, the power should be turned on in order V_{DD1} , Logic input V_{DD2} , video signal input. It should be turned off in the opposite order. This relationship should be followed during transition periods as well.
 2. The sampling of the video signal of this IC is only the simultaneous 3 output sampling of C_1 , C_2 , C_3 . Incidentally, it is designing around of the input of the video signal in 10 MHz MAX. If a video signal with a higher frequency is input, the data may not be correctly displayed.
 3. Insert a capacitor of 0.1 μ F between V_{DD1} and V_{SS1} , and V_{DD2} and V_{SS2} . Unless the power supply is reinforced, the supply voltage may fluctuate, making the sampling voltage abnormal.
 4. If noise is superimposed on the start pulse pin, the data may not be displayed. For this reason, be sure to input CX signal during the vertical blanking period.
 5. If the start pulse width is extended by half the clock or longer, the sampling start timing SHP1 does not change from normal timing; therefore, the sampling operation is performed normally.

5. FUNCTION DESCRIPTION

5.1 Switching of Sample & Hold Circuits

Two sample-and-hold circuits are switched.

CX	Output	Sample & hold operation
L	Sample & Hold Circuit 1 (S&H1)	Sample & Hold Circuit 2 (S&H2)
H	Sample & Hold Circuit 2 (S&H2)	Sample & Hold Circuit 1 (S&H1)

5.2 Sample & Hold and Output

Relation between video signals C₁, C₂ and C₃ and output pins and two sample & hold circuits.

5.2.1 300 output

CX		S ₁ (S ₃₀₀)	S ₂ (S ₂₉₉)	S ₃ (S ₂₉₈)	S ₄ (S ₂₉₇)	...	S ₂₉₉ (S ₂)	S ₃₀₀ (S ₁)
L	Sampling	C ₁₋₂ (C ₃₋₂)	C ₂₋₂ (C ₂₋₂)	C ₃₋₂ (C ₁₋₂)	C ₁₋₂ (C ₃₋₂)	...	C ₂₋₂ (C ₂₋₂)	C ₃₋₂ (C ₁₋₂)
	Output	C ₁₋₁ (C ₃₋₁)	C ₂₋₁ (C ₂₋₁)	C ₃₋₁ (C ₁₋₁)	C ₁₋₁ (C ₃₋₁)	...	C ₂₋₁ (C ₂₋₁)	C ₃₋₁ (C ₁₋₁)
H	Sampling	C ₁₋₁ (C ₃₋₁)	C ₂₋₁ (C ₂₋₁)	C ₃₋₁ (C ₁₋₁)	C ₁₋₁ (C ₃₋₁)	...	C ₂₋₁ (C ₂₋₁)	C ₃₋₁ (C ₁₋₁)
	Output	C ₁₋₂ (C ₃₋₂)	C ₂₋₂ (C ₂₋₂)	C ₃₋₂ (C ₁₋₂)	C ₁₋₂ (C ₃₋₂)	...	C ₂₋₂ (C ₂₋₂)	C ₃₋₂ (C ₁₋₂)

Remark C_{m-n} = m: Video input, n: Sample & Hold

5.2.2 288 output

CX		S ₁ (S ₂₈₈)	S ₂ (S ₂₈₇)	S ₃ (S ₂₈₆)	S ₄ (S ₂₈₅)	...	S ₂₈₇ (S ₂)	S ₂₈₈ (S ₁)
L	Sampling	C ₁₋₂ (C ₃₋₂)	C ₂₋₂ (C ₂₋₂)	C ₃₋₂ (C ₁₋₂)	C ₁₋₂ (C ₃₋₂)	...	C ₂₋₂ (C ₂₋₂)	C ₃₋₂ (C ₁₋₂)
	Output	C ₁₋₁ (C ₃₋₁)	C ₂₋₁ (C ₂₋₁)	C ₃₋₁ (C ₁₋₁)	C ₁₋₁ (C ₃₋₁)	...	C ₂₋₁ (C ₂₋₁)	C ₃₋₁ (C ₁₋₁)
H	Sampling	C ₁₋₁ (C ₃₋₁)	C ₂₋₁ (C ₂₋₁)	C ₃₋₁ (C ₁₋₁)	C ₁₋₁ (C ₃₋₁)	...	C ₂₋₁ (C ₂₋₁)	C ₃₋₁ (C ₁₋₁)
	Output	C ₁₋₂ (C ₃₋₂)	C ₂₋₂ (C ₂₋₂)	C ₃₋₂ (C ₁₋₂)	C ₁₋₂ (C ₃₋₂)	...	C ₂₋₂ (C ₂₋₂)	C ₃₋₂ (C ₁₋₂)

Remark C_{m-n} = m: Video input, n: Sample & Hold

6. TIMING CHART (Right shift, 300 output)

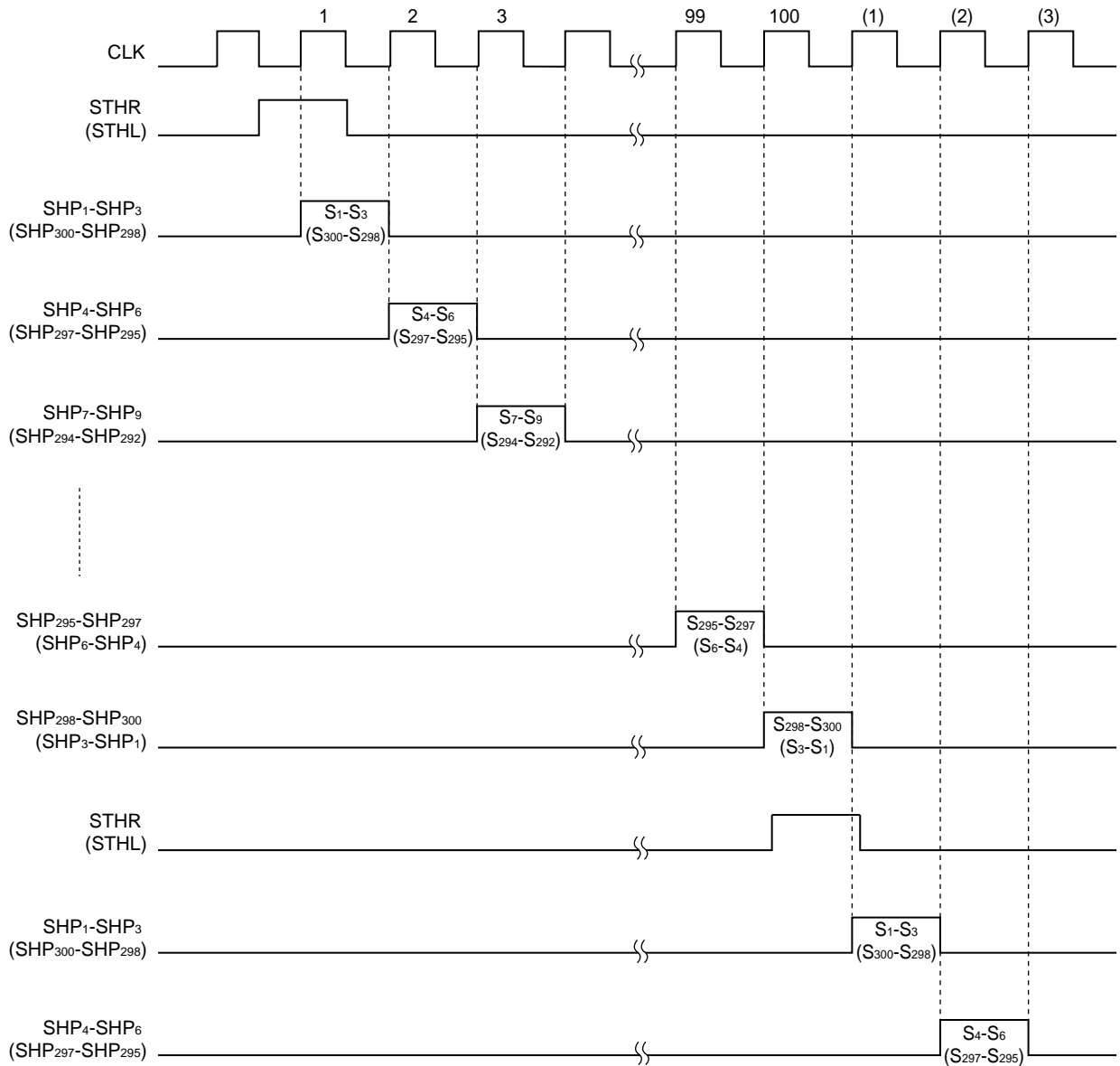

7. ELECTRICAL SPECIFICATIONS

Absolute Maximum Ratings (T_A = +25 °C, V_{SS1} = V_{SS2} = 0 V)

Parameter	Symbol	Rating	Unit
Logic Part Supply Voltage	V _{DD1}	-0.3 to +7.0	V
Driver Part Supply Voltage	V _{DD2}	-0.3 to +7.0	V
Input Voltage	V _I	-0.3 to V _{DD1/2} + 0.3	V
Output Voltage	V _O	-0.3 to V _{DD1/2} + 0.3	V
Operating Ambient Temperature	T _A	-30 to +85	°C
Storage Temperature	T _{stg}	-55 to +125	°C

Caution If the absolute maximum rating of even one of the above parameters is exceeded even momentarily, the quality of the product may be degraded. Absolute maximum ratings, therefore, specify the values exceeding which the product may be physically damaged. Be sure to use the product within the range of the absolute maximum ratings.

★ **Recommended Operating Range (T_A = -30 to +85 °C, V_{DD2} ≥ V_{DD1}, V_{SS1} = V_{SS2} = 0 V)**

Parameter	Symbol	Conditions	MIN.	TYP.	MAX.	Unit
Logic Part Supply Voltage	V _{DD1}		3.0		5.5	V
Driver Part Supply Voltage	V _{DD2}		4.5	5.0	5.5	V
Video Input Voltage	V _{V1}		V _{SS2} + 0.2		V _{DD2} - 0.2	V
Driver Part Output Voltage	V _{O2}		V _{SS2} + 0.2		V _{DD2} - 0.2	V
Maximum Clock Frequency	f _{MAX.}	CLK	20			MHz
Output Load Capacitance	C _L	1 output			50	pF

★ Electrical Characteristics ($T_A = -30$ to $+85$ °C, $V_{DD1} = 3.0$ V to 5.5 V, $V_{DD2} = 5.0$ V \pm 0.5 V, $V_{DD2} \geq V_{DD1}$,
 $V_{SS1} = V_{SS2} = 0$ V)

Parameter	Symbol	Conditions	MIN.	TYP.	MAX.	Unit
Low-Level Driver Part Output Voltage	V_{VOL}	S ₁ to S ₃₀₀			$V_{SS2} + 0.2$	V
High-Level Driver Part Output Voltage	V_{VOH}		$V_{DD2} - 0.2$			V
High-Level Input Voltage	V_{IH}	CLK, STHR (L), R, L, O _{sel} , CX	$0.7 V_{DD1}$		V_{DD1}	V
Low-Level Input Voltage	V_{IL}		V_{SS1}		$0.3 V_{DD1}$	V
Input Leak Current	I_{IL}	All Inputs	-1.0		+1.0	μA
High-Level Output Voltage	V_{LOH}	STHR (STHL), $I_{OH} = -1.0$ mA	$0.85 V_{DD1}$			V
Low-Level Output Voltage	V_{LOH}	STHR (STHL), $I_{OL} = +1.0$ mA			$0.15 V_{DD1}$	V
Reference Voltage	V_{REF1}	$V_{DD2} = 5.0$ V, $V_{VI} = 0.5$ V, $T_A = 25^\circ\text{C}$		0.5		V
	V_{REF2}	$V_{DD2} = 5.0$ V, $V_{VI} = 2.5$ V, $T_A = 25^\circ\text{C}$		2.5		V
	V_{REF3}	$V_{DD2} = 5.0$ V, $V_{VI} = 4.5$ V, $T_A = 25^\circ\text{C}$		4.5		V
Output Voltage Deviation	ΔV_{VO1}	$V_{DD2} = 5.0$ V, $V_{VI} = 0.5$ V, $T_A = 25^\circ\text{C}$			± 20	mV
	ΔV_{VO2}	$V_{DD2} = 5.0$ V, $V_{VI} = 2.5$ V, $T_A = 25^\circ\text{C}$			± 20	mV
	ΔV_{VO3}	$V_{DD2} = 5.0$ V, $V_{VI} = 4.5$ V, $T_A = 25^\circ\text{C}$			± 20	mV
Logic Dynamic Current Consumption	I_{DD1}	$V_{DD1} = 5.0$ V with no load ^{Note}		1.0	3.5	mA
Driver Dynamic Current Consumption	I_{DD2}	$V_{DD2} = 5.0$ V with no load ^{Note}		5.6	8.5	mA

Note $f_{CLK} = 15$ MHz, $f_{CX} = 17$ kHz.

★ **Switching Characteristics** ($T_A = -30$ to $+85$ °C, $V_{DD1} = 3.0$ V to 5.5 V, $V_{DD2} = 5.0$ V \pm 0.5 V, $V_{DD2} \geq V_{DD1}$, $V_{SS1} = V_{SS2} = 0$ V)

Parameter	Symbol	Condition	MIN.	TYP.	MAX.	Unit
Start Pulse Delay Time	t _{PHL1}	C _L = 20 pF	7		43	ns
	t _{PLH1}	CLK → STHL(STHR)	7		43	ns
Driver Output Delay Time	t _{PLH2}	V _{DD2} = 5.0 V			8	μs
	t _{PLH3}	R _L = 2 kΩ			16	μs
	t _{PHL2}	C _L = 25 pF x 2			8	μs
	t _{PHL3}				16	μs
Input Capacitance	C _{I1}	STHR(STHL), T _A =25 °C		10	20	pF
	C _{I2}	C ₁ ,C ₂ ,C ₃ , T _A =25 °C		40	60	pF
	C _{I3}	STHR(STHL),C ₁ ,C ₂ ,C ₃ excluded input, T _A =25 °C		7	15	pF

★ **Timing Requirement** ($T_A = -30$ to $+85$ °C, $V_{DD1} = 3.0$ V to 5.5 V, $V_{DD2} = 5.0$ V \pm 0.5 V, $V_{DD2} \geq V_{DD1}$, $V_{SS1} = V_{SS2} = 0$ V)

Parameter	Symbol	Condition	MIN.	TYP.	MAX.	Unit
Clock Pulse Width	PW _{CLK}		50			ns
Clock Pulse High Period	PW _{CLK(H)}		15			ns
Clock Pulse Low Period	PW _{CLK(L)}		15			ns
Start Pulse Setup Time	t _{setup}		7			ns
Start Pulse Setup Time	t _{hold}		7			ns
★ Start Pulse – CX Time	t _{STH-CX}		50			ns
CX Setup Time	t _{CXsetup}		1.0			μs
CX Hold Time	t _{CXhold}		50			ns
CLK Stop Period ^{Note}	t _{CLKstop}		Refer to 8. SWITHING CHARACTERISTICS WAVEFORM.			

Note This shows the period where it is possible for CLK stop.

★ 8. SWITCHING CHARACTERISTICS WAVEFORM (R,I/L=H)

Unless otherwise specified, the input level is defined to be $V_{IH} = 0.7 V_{DD1}$, $V_{IL} = 0.3 V_{DD1}$.

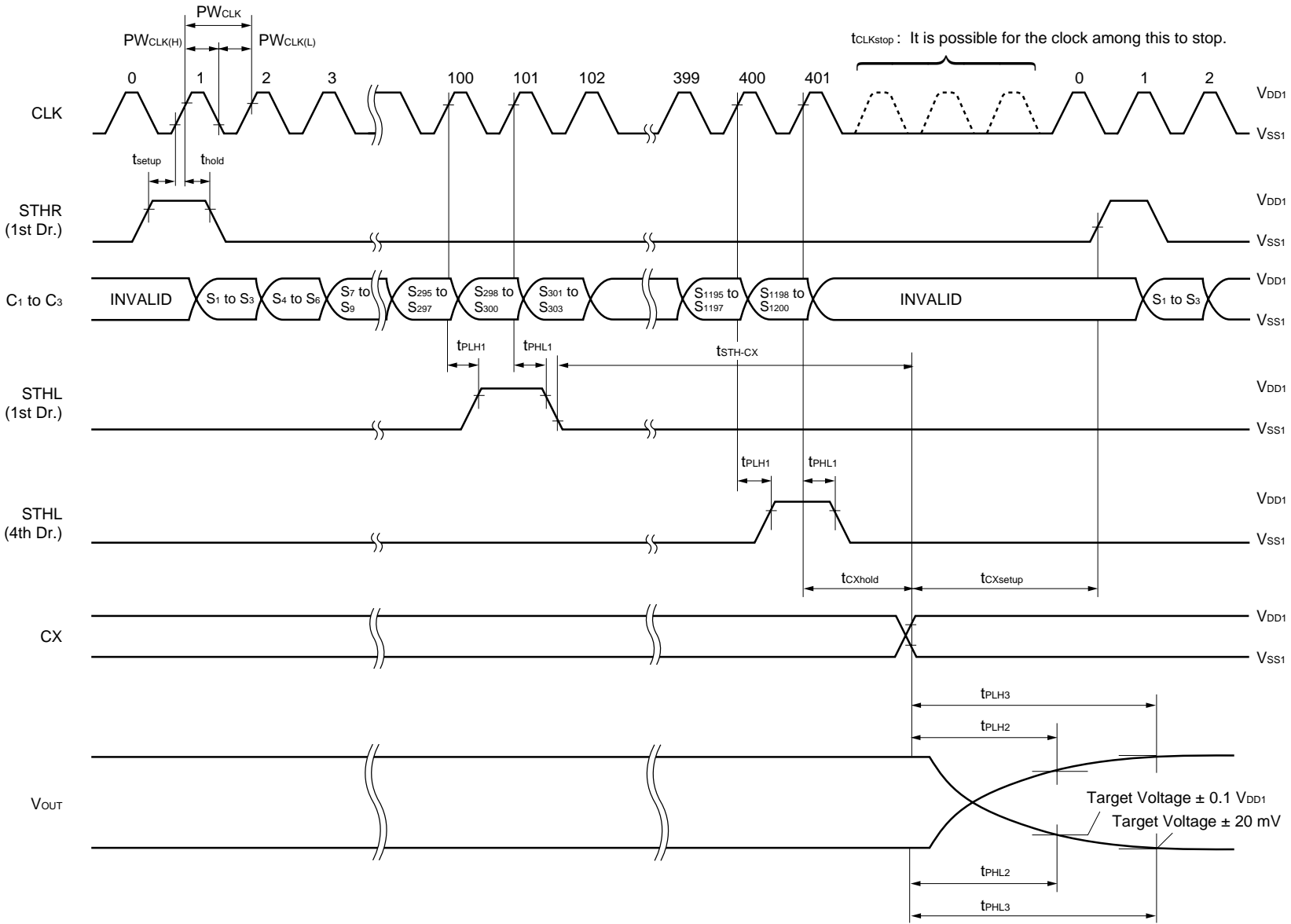

9. RECOMMENDED MOUNTING CONDITIONS

The following conditions must be met for mounting conditions of the μ PD16780.

For more details, refer to the **Semiconductor Device Mounting Technology Manual(C10535E)**.

Please consult with our sales offices in case other mounting process is used, or in case the mounting is done under different conditions.

μ PD16780N-xxx : TCP(TAB Package)

Mounting Condition	Mounting Method	Condition
Thermocompression	Soldering	Heating tool 300 to 350 °C, heating for 2 to 3 sec ; pressure 100g(per solder)
	ACF (Adhesive Conductive Film)	Temporary bonding 70 to 100 °C ; pressure 3 to 8 kg/cm2; time 3 to 5 sec. Real bonding 165 to 180 °C pressure 25 to 45 kg/cm2 time 30 to 40secs(When using the anisotropy conductive film SUMIZAC1003 of Sumitomo Bakelite,Ltd).

Caution To find out the detailed conditions for mounting the ACF part, please contact the ACF manufacturing company. Be sure to avoid using two or more mounting methods at a time.

[MEMO]

[MEMO]

NOTES FOR CMOS DEVICES**① PRECAUTION AGAINST ESD FOR SEMICONDUCTORS**

Note:

Strong electric field, when exposed to a MOS device, can cause destruction of the gate oxide and ultimately degrade the device operation. Steps must be taken to stop generation of static electricity as much as possible, and quickly dissipate it once, when it has occurred. Environmental control must be adequate. When it is dry, humidifier should be used. It is recommended to avoid using insulators that easily build static electricity. Semiconductor devices must be stored and transported in an anti-static container, static shielding bag or conductive material. All test and measurement tools including work bench and floor should be grounded. The operator should be grounded using wrist strap. Semiconductor devices must not be touched with bare hands. Similar precautions need to be taken for PW boards with semiconductor devices on it.

② HANDLING OF UNUSED INPUT PINS FOR CMOS

Note:

No connection for CMOS device inputs can be cause of malfunction. If no connection is provided to the input pins, it is possible that an internal input level may be generated due to noise, etc., hence causing malfunction. CMOS devices behave differently than Bipolar or NMOS devices. Input levels of CMOS devices must be fixed high or low by using a pull-up or pull-down circuitry. Each unused pin should be connected to V_{DD} or GND with a resistor, if it is considered to have a possibility of being an output pin. All handling related to the unused pins must be judged device by device and related specifications governing the devices.

③ STATUS BEFORE INITIALIZATION OF MOS DEVICES

Note:

Power-on does not necessarily define initial status of MOS device. Production process of MOS does not define the initial operation status of the device. Immediately after the power source is turned ON, the devices with reset function have not yet been initialized. Hence, power-on does not guarantee out-pin levels, I/O settings or contents of registers. Device is not initialized until the reset signal is received. Reset operation must be executed immediately after power-on for devices having reset function.

Reference Documents

NEC Semiconductor Device Reliability/Quality Control System(C10983E)

Quality Grades to NEC's Semiconductor Devices(C11531E)

- **The information in this document is subject to change without notice. Before using this document, please confirm that this is the latest version.**
 - No part of this document may be copied or reproduced in any form or by any means without the prior written consent of NEC Corporation. NEC Corporation assumes no responsibility for any errors which may appear in this document.
 - NEC Corporation does not assume any liability for infringement of patents, copyrights or other intellectual property rights of third parties by or arising from use of a device described herein or any other liability arising from use of such device. No license, either express, implied or otherwise, is granted under any patents, copyrights or other intellectual property rights of NEC Corporation or others.
 - Descriptions of circuits, software, and other related information in this document are provided for illustrative purposes in semiconductor product operation and application examples. The incorporation of these circuits, software, and information in the design of the customer's equipment shall be done under the full responsibility of the customer. NEC Corporation assumes no responsibility for any losses incurred by the customer or third parties arising from the use of these circuits, software, and information.
 - While NEC Corporation has been making continuous effort to enhance the reliability of its semiconductor devices, the possibility of defects cannot be eliminated entirely. To minimize risks of damage or injury to persons or property arising from a defect in an NEC semiconductor device, customers must incorporate sufficient safety measures in its design, such as redundancy, fire-containment, and anti-failure features.
 - NEC devices are classified into the following three quality grades:
"Standard", "Special", and "Specific". The Specific quality grade applies only to devices developed based on a customer designated "quality assurance program" for a specific application. The recommended applications of a device depend on its quality grade, as indicated below. Customers must check the quality grade of each device before using it in a particular application.
 - Standard: Computers, office equipment, communications equipment, test and measurement equipment, audio and visual equipment, home electronic appliances, machine tools, personal electronic equipment and industrial robots
 - Special: Transportation equipment (automobiles, trains, ships, etc.), traffic control systems, anti-disaster systems, anti-crime systems, safety equipment and medical equipment (not specifically designed for life support)
 - Specific: Aircraft, aerospace equipment, submersible repeaters, nuclear reactor control systems, life support systems or medical equipment for life support, etc.
- The quality grade of NEC devices is "Standard" unless otherwise specified in NEC's Data Sheets or Data Books. If customers intend to use NEC devices for applications other than those specified for Standard quality grade, they should contact an NEC sales representative in advance.