

**GaAs MMIC DBS
TWIN IF SWITCH AMPLIFIER**

UPG2050GR

FEATURES

- **TWO INDEPENDENT IF AMPLIFIER CHANNELS**
- **TYPICAL GAIN PER CHANNEL:**
14 dB ($Z_0 = 50 \Omega$)
- **FREQUENCY RANGE OF 950 MHz TO 2150 MHz**
- **INTEGRAL SWITCHING TO CHANNEL INPUT
TO EITHER CHANNEL OUTPUT**
- **CHANNEL TO CHANNEL ISOLATION:**
30 dB TYP
- **SMALL 16 PIN HTSSOP PACKAGE**

OUTLINE DIMENSIONS (Units in mm)

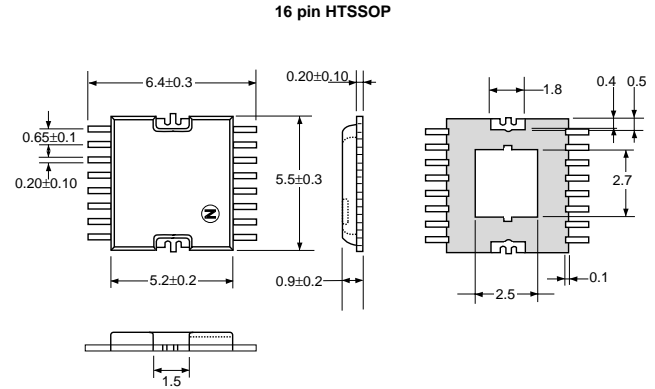

DESCRIPTION

The UPG2050GR is intended for use in Direct Broadcast Satellite (DBS) applications within the Low Noise Block (LNB) down-converter for systems where at least two LNB outputs are required. It offers two intermediate frequency amplifier channels that can independently select 1 of 2 IF inputs. It is housed in a very small 16 pin plastic HTSSOP package and is available on tape and reel.

NEC's stringent quality assurance and test procedures assure the highest reliability and performance.

ELECTRICAL CHARACTERISTICS

($T_A = +25^\circ\text{C}$, $V_{DD} = +5\text{ V}$, V_{CONT1} to $V_{CONT4} = 0/+5\text{ V}$, $Z_0 = 50\Omega$ each port, unless otherwise specified)

PART NUMBER PACKAGE OUTLINE			UPG2050GR 16 pin HTSSOP		
SYMBOLS	PARAMETERS AND CONDITIONS	UNITS	MIN	TYP	MAX
I _{DD}	Supply Current, $V_{DD} = +5\text{ V}$, RF OFF	mA	25	40	50
GA	Power Gain, $f = 1.5\text{ GHz}$, $P_{IN} = -30\text{ dBm}$	dB	11	14	19
Δ GA	Insertion Loss Flatness, $ G_A(0.95\text{ GHz}) - G_A(1.5\text{ GHz}) $	dB	—	1.5	3.5
Δ GA	Insertion Loss Flatness, $ G_A(1.5\text{ GHz}) - G_A(2.15\text{ GHz}) $	dB	—	2.0	3.5
ISOL	Channel Isolation, $f = 0.95\text{ GHz}$ to 2.15 GHz	dB	25	30	—
RL _{OUT}	Output Return Loss, $f = 0.95\text{ GHz}$ to 2.15 GHz	dB	—	10	—
P _{OUT}	Output Power, $f = 1.5\text{ GHz}$, $P_{IN} = -5\text{ dBm}$	dBm	5	8	—
I _{CONT}	Control Current, $V_{CONT} = +5\text{ V}/0\text{ V}$, RF OFF	mA	—	—	0.5

ABSOLUTE MAXIMUM RATINGS¹ (T_A = +25°C)

SYMBOLS	PARAMETERS	UNITS	RATINGS
V _{DD}	Supply Voltage	V	+6
V _{CONT1, 2, 3, 4}	Control Voltage 1, 2, 3, 4	V	-1.0 to +6.0
P _T	Total Power Dissipation ²	W	2
T _A	Operating Ambient Temp.	°C	-40 to +85
T _{STG}	Storage Temperature	°C	-65 to +150

Notes:

1. Operation in excess of any one of these parameters may result in permanent damage.
2. Mounted on a 50 x 50 x 1.6 mm double copper clad epoxy glass PWB, T_C = +85°C.

EVALUATION CIRCUIT (V_{DD} = +6.0 V, V_{CONT1} to V_{CONT4} = +5 V/0 V, Z₀ = 50 Ω, DC Blocking Capacitor = 51 pF)

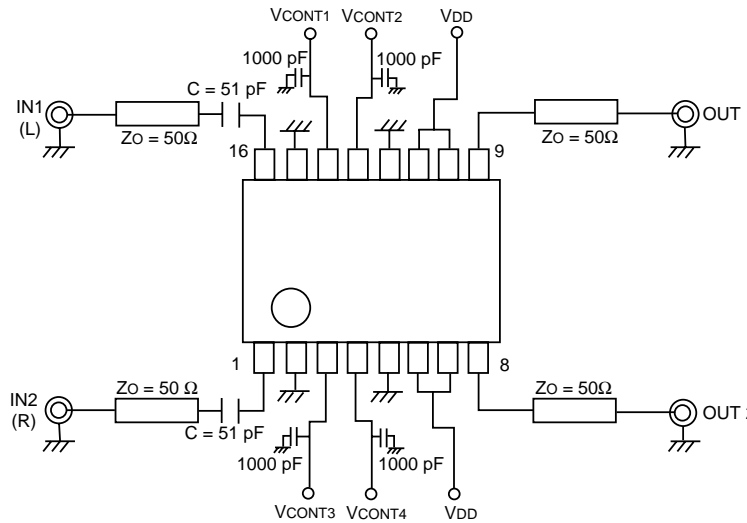

ORDERING INFORMATION

PART NUMBER	PACKAGE	QUANTITY
UPG2050GR-E1	16 Pin Plastic HTSSOP	3000 pcs/Reel

RECOMMENDED OPERATING CONDITIONS (T_A = +25°C)

SYMBOL	PARAMETER	UNITS	MIN	TYP	MAX
V _{DD}	Supply Voltage	V	+4.5	+5	+5.5
V _{CONT(H)}	Control Voltage (High)	V	+4.5	+5	+6.5
V _{CONT(L)}	Control Voltage (Low)	V	-0.5	0	+0.5

CHANNEL SELECT TRUTH TABLE

OUTPUT		On-Channel	CONTROL PIN			
OUT1	OUT2		V _{CONT1}	V _{CONT2}	V _{CONT3}	V _{CONT4}
L	L	IN1—OUT1 IN1—OUT2	Low	High	High	Low
L	R	IN1—OUT1 IN2—OUT2	Low	High	Low	High
R	L	IN2—OUT1 IN1—OUT2	High	Low	High	Low
R	R	IN2—OUT1 IN2—OUT2	High	Low	Low	High

PIN CONNECTION AND INTERNAL BLOCK DIAGRAM

PIN NO.	CONNECTION	PIN NO.	CONNECTION
1	IN2	9	OUT1
2	GND	10	V _{DD}
3	V _{CONT3}	11	V _{DD}
4	V _{CONT4}	12	GND
5	GND	13	V _{CONT2}
6	V _{DD}	14	V _{CONT1}
7	V _{DD}	15	GND
8	OUT2	16	IN1

TOP VIEW

