



μPSD325X

Flash Programmable System Devices with 8032 Microcontroller Core and 256Kbit SRAM

FEATURES SUMMARY

- The μPSD325X devices combine a Flash PSD architecture with an 8032 microcontroller core.
The μPSD325X devices of Flash PSDs feature dual banks of Flash memory, SRAM, general purpose I/O and programmable logic, supervisory functions and access via USB, I²C, ADC, DDC and PWM channels, and an on-board 8032 microcontroller core, with two UARTs, three 16-bit Timer/Counters and two External Interrupts. As with other Flash PSD families, the μPSD325X devices are also in-system programmable (ISP) via a JTAG ISP interface.
- Large 32KByte SRAM with battery back-up option
- Dual bank Flash memories
 - 128KByte or 256KByte main Flash memory
 - 32KByte secondary Flash memory
- Content Security
 - Block access to Flash memory
- Programmable Decode PLD for flexible address mapping of all memories within 8032 space.
- High-speed clock standard 8032 core (12-cycle)
- USB Interface (some devices only)
- I²C interface for peripheral connections
- 5 Pulse Width Modulator (PWM) channels
- Analog-to-Digital Converter (ADC)
- Standalone Display Data Channel (DDC)
- Six I/O ports with up to 50 I/O pins
- 3000 gate PLD with 16 macrocells
- Supervisor functions with Watchdog Timer
- In-System Programming (ISP) via JTAG
- Zero-Power Technology
- Single Supply Voltage
 - 4.5 to 5.5V
 - 3.0 to 3.6V

Figure 1. 52-lead, Thin, Quad, Flat Package

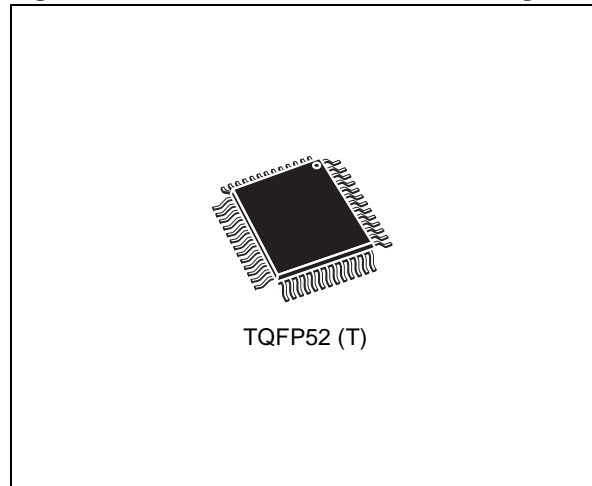

Figure 2. 80-lead, Thin, Quad, Flat Package

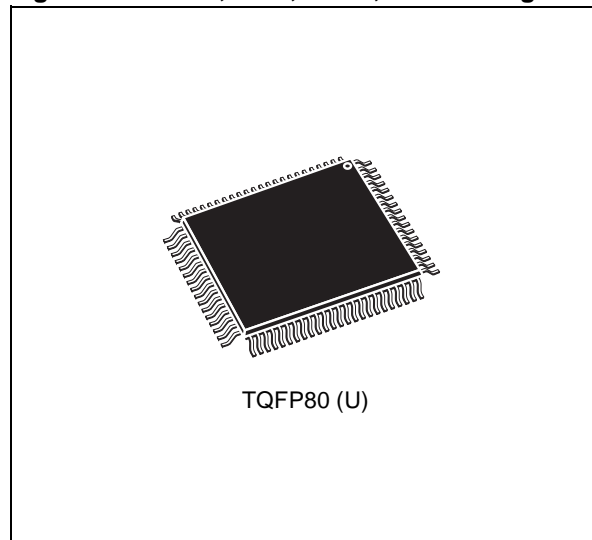

TABLE OF CONTENTS

SUMMARY DESCRIPTION **11**

 μPSD325X Devices Product Matrix (Table 1.) 12

 TQFP52 Connections (Figure 3.) 12

 TQFP80 Connections (Figure 4.) 13

 80-Pin Package Pin Description (Table 2.) 14

52 PIN PACKAGE I/O PORT **16**

ARCHITECTURE OVERVIEW **17**

 Memory Organization 17

 Memory Map and Address Space (Figure 5.) 17

 Registers 17

 8032 MCU Registers (Figure 6.) 17

 Configuration of BA 16-bit Registers (Figure 7.) 18

 Stack Pointer (Figure 8.) 18

 PSW (Program Status Word) Register (Figure 9.) 19

 Program Memory 19

 Data memory 19

 RAM 19

 Interrupt Location of Program Memory (Figure 10.) 19

 XRAM-DDC 19

 XRAM-PSD 19

 SFR 20

 RAM Address (Table 3.) 20

 Addressing Modes 20

 Direct Addressing (Figure 11.) 20

 Indirect Addressing (Figure 12.) 20

 Indexed Addressing (Figure 13.) 21

 Arithmetic Instructions 21

 Arithmetic Instructions (Table 4.) 22

 Logical Instructions 22

 Logical Instructions (Table 5.) 23

 Data Transfers 24

 Data Transfer Instructions that Access Internal Data Memory Space (Table 6.) 24

 Shifting a BCD Number Two Digits to the Right (using direct MOVs: 14 bytes) (Table 7.) 25

 Shifting a BCD Number Two Digits to the Right (using direct XCHs: 9 bytes) (Table 8.) 25

 Shifting a BCD Number One Digit to the Right (Table 9.) 25

 Data Transfer Instruction that Access External Data Memory Space (Table 10.) 26

 Lookup Table READ Instruction (Table 11.) 26

 Boolean Instructions 27

 Boolean Instructions (Table 12.) 27

 Relative Offset 27

Jump Instructions	28
Unconditional Jump Instructions (Table 13.)	28
Machine Cycles	29
Conditional Jump Instructions	29
State Sequence in μPSD325X Devices (Figure 14.)	30
μPSD325X HARDWARE DESCRIPTION	31
μPSD325X devices Functional Modules (Figure 15.)	31
MCU MODULE DISCRPTION	32
Special Function Registers	32
SFR Memory Map (Table 15.)	32
List of all SFR (Table 16.)	33
PSD Module Register Address Offset (Table 17.)	37
INTERRUPT SYSTEM.	39
External Int0	39
Timer 0 and 1 Interrupts	39
Timer 2 Interrupt	39
I2C Interrupt.	39
External Int1	39
DDC Interrupt	39
USB Interrupt.	39
USART Interrupt	40
Interrupt System (Figure 16.)	40
SFR Register (Table 18.)	41
Interrupt Priority Structure	41
Interrupts Enable Structure	41
Priority Levels (Table 19.)	41
Description of the IE Bits (Table 20.)	41
Description of the IEA Bits (Table 21.)	42
Description of the IP Bits (Table 22.)	42
Description of the IPA Bits (Table 23.)	42
How Interrupts are Handled.	43
Vector Addresses (Table 24.)	43
POWER-SAVING MODE.	44
Idle Mode	44
Power-Down Mode	44
Power-Saving Mode Power Consumption (Table 25.)	44
Power Control Register	44
Pin Status During Idle and Power-down Mode (Table 26.)	44
Description of the PCON Bits (Table 27.)	44
Idle Mode	44

I/O PORTS (MCU Module)	46
I/O Port Functions (Table 28.)	46
P1SFS (91H) (Table 29.)	46
P3SFS (93H) (Table 30.)	46
P4SFS (94H) (Table 31.)	46
PORT Type and Description	47
PORT Type and Description (Part 1) (Figure 17.)	47
PORT Type and Description (Part 2) (Figure 18.)	48
OSCILLATOR	49
Oscillator (Figure 19.)	49
SUPERVISORY	49
RESET Configuration (Figure 20.)	49
External Reset	50
Low VDD Voltage Reset	50
Watchdog Timer Overflow	50
USB Reset	50
WATCHDOG TIMER	51
Watchdog Timer Key Register (WDKEY: 0AEH) (Table 32.)	51
Description of the WDKEY Bits (Table 33.)	51
RESET Pulse Width (Figure 21.)	52
Watchdog Timer Clear Register (WDRST: 0A6H) (Table 34.)	52
Description of the WDRST Bits (Table 35.)	52
TIMER/COUNTERS (TIMER0, TIMER1 AND TIMER2)	53
Timer0 and Timer1	53
Control Register (TCON) (Table 36.)	53
Description of the TCON Bits (Table 37.)	53
TMOD Register (TMOD) (Table 38.)	54
Description of the TMOD Bits (Table 39.)	54
Timer/Counter Mode 0: 13-bit Counter (Figure 22.)	55
Timer/Counter Mode 2: 8-bit Auto-reload (Figure 23.)	55
Timer/Counter Mode 3: Two 8-bit Counters (Figure 24.)	56
Timer 2	56
Timer/Counter 2 Control Register (T2CON) (Table 40.)	57
Description of the T2CON Bits (Table 41.)	57
Timer/Counter2 Operating Modes (Table 42.)	58
Timer 2 in Capture Mode (Figure 25.)	58
Timer 2 in Auto-Reload Mode (Figure 26.)	59

STANDARD SERIAL INTERFACE (UART)	60
Multiprocessor Communications	60
Serial Port Control Register	60
Serial Port Control Register (SCON) (Table 43.)	60
Description of the SCON Bits (Table 44.)	61
Timer 1-Generated Commonly Used Baud Rates (Table 45.)	62
Serial Port Mode 0, Block Diagram (Figure 27.)	65
Serial Port Mode 0, Waveforms (Figure 28.)	66
Serial Port Mode 1, Block Diagram (Figure 29.)	66
Serial Port Mode 1, Waveforms (Figure 30.)	67
Serial Port Mode 2, Block Diagram (Figure 31.)	67
Serial Port Mode 2, Waveforms (Figure 32.)	68
Serial Port Mode 3, Block Diagram (Figure 33.)	68
Serial Port Mode 3, Waveforms (Figure 34.)	69
ANALOG-TO-DIGITAL CONVERTOR (ADC)	70
ADC Interrupt	70
A/D Block Diagram (Figure 35.)	70
ADC SFR Memory Map (Table 46.)	71
Description of the ACON Bits (Table 47.)	71
ADC Clock Input (Table 48.)	71
PULSE WIDTH MODULATION (PWM)	72
4-channel PWM unit (PWM 0-3)	72
Four-Channel 8-bit PWM Block Diagram (Figure 36.)	73
PWM SFR Memory Map (Table 49.)	74
Programmable Period 8-bit PWM	75
Programmable PWM 4 Channel Block Diagram (Figure 37.)	75
PWM 4 Channel Operation	76
PWM 4 With Programmable Pulse Width and Frequency (Figure 38.)	76
I2C INTERFACE	77
Block Diagram of the I2C Bus Serial I/O (Figure 39.)	77
Serial Control Register (SxCON: S1CON, S2CON) (Table 50.)	78
Description of the SxCON Bits (Table 51.)	78
Selection of the Serial Clock Frequency SCL in Master Mode (Table 52.)	78
Serial Status Register (SxSTA: S1STA, S2STA)	79
Data Shift Register (SxDAT: S1DAT, S2DAT)	79
Serial Status Register (SxSTA) (Table 53.)	79
Description of the SxSTA Bits (Table 54.)	79
Data Shift Register (SxDAT: S1DAT, S2DAT) (Table 55.)	79
Address Register (SxADR: S1ADR, S2ADR)	80
Address Register (SxADR) (Table 56.)	80
Start /Stop Hold Time Detection Register (S1SETUP, S2SETUP) (Table 57.)	80
System Cock of 40MHz (Table 58.)	80
System Clock Setup Examples (Table 59.)	80
Programmer's Guide for I2C and DDC2	81

DDC INTERFACE	83
DDC Interface Block Diagram (Figure 40.)	83
Special Function Register for the DDC Interface	84
DDC SFR Memory Map (Table 60.)	84
Description of the DDCON Register Bits (Table 61.)	85
SWNEB Bit Function (Table 62.)	86
Host Type Detection	87
Host Type Detection (Figure 41.)	87
DDC1 Protocol	88
Transmission Protocol in the DDC1 Interface (Figure 42.)	88
DDC2B Protocol	89
Conceptual Structure of the DDC Interface (Figure 43.)	89
USB HARDWARE	90
USB related registers	90
USB Address Register (UADR: 0EEh) (Table 63.)	90
Description of the UADR Bits (Table 64.)	90
USB Interrupt Enable Register (UIEN: 0E9h) (Table 65.)	91
Description of the UIEN Bits (Table 66.)	91
USB Interrupt Status Register (UISTA: 0E8h) (Table 67.)	91
Description of the UISTA Bits (Table 68.)	92
USB Endpoint0 Transmit Control Register (UCON0: 0EAh) (Table 69.)	93
Description of the UCON0 Bits (Table 70.)	93
USB Endpoint1 (and 2) Transmit Control Register (UCON1: 0EBh) (Table 71.)	94
Description of the UCON1 Bits (Table 72.)	94
USB Control Register (UCON2: 0ECh) (Table 73.)	95
Description of the UCON2 Bits (Table 74.)	95
USB Endpoint0 Status Register (USTA: 0EDh) (Table 75.)	95
Description of the USTA Bits (Table 76.)	95
USB Endpoint0 Data Receive Register (UDR0: 0EFh) (Table 77.)	95
USB Endpoint0 Data Transmit Register (UDT0: 0E7h) (Table 78.)	95
USB Endpoint1 Data Transmit Register (UDT1: 0E6h) (Table 79.)	95
USB SFR Memory Map (Table 80.)	96
Transceiver	97
Low Speed Driver Signal Waveforms (Figure 44.)	97
Receiver Characteristics	98
Differential Input Sensitivity Over Entire Common Mode Range (Figure 45.)	98
External USB Pull-Up Resistor	99
USB Data Signal Timing and Voltage Levels (Figure 46.)	99
Receiver Jitter Tolerance (Figure 47.)	99
Differential to EOP Transition Skew and EOP Width (Figure 48.)	100
Differential Data Jitter (Figure 49.)	100
Transceiver DC Characteristics (Table 81.)	101
Transceiver AC Characteristics (Table 82.)	101

PSD MODULE	102
Functional Overview	102
PSD MODULE Block Diagram (Figure 50.)	103
In-System Programming (ISP)	104
Methods of Programming Different Functional Blocks of the PSD MODULE (Table 83.)	104
DEVELOPMENT SYSTEM	105
PSDsoft Express Development Tool (Figure 51.)	105
PSD MODULE REGISTER DESCRIPTION AND ADDRESS OFFSET	106
Register Address Offset (Table 84.)	106
PSD MODULE DETAILED OPERATION	107
MEMORY BLOCKS	107
Primary Flash Memory and Secondary Flash memory Description	107
Memory Block Select Signals	107
Instructions	108
Instructions (Table 85.)	109
Power-down Instruction and Power-up Mode	110
READ	110
Status Bit (Table 86.)	111
Programming Flash Memory	112
Data Polling Flowchart (Figure 52.)	112
Data Toggle Flowchart (Figure 53.)	113
Erasing Flash Memory	114
Specific Features	115
Sector Protection/Security Bit Definition – Flash Protection Register (Table 87.)	115
Sector Protection/Security Bit Definition – Secondary Flash Protection Register (Table 88.)	115
SRAM	116
Sector Select and SRAM Select	116
Priority Level of Memory and I/O Components in the PSD MODULE (Figure 54.)	117
VM Register (Table 89.)	117
Separate Space Mode (Figure 55.)	118
Combined Space Mode (Figure 56.)	118
Page Register	119
Page Register (Figure 57.)	119
PLDs	120
DPLD and CPLD Inputs (Table 90.)	120
The Turbo Bit in PSD MODULE	120
PLD Diagram (Figure 58.)	121
Decode PLD (DPLD)	122
DPLD Logic Array (Figure 59.)	122
Complex PLD (CPLD)	123
Macrocell and I/O Port (Figure 60.)	123
Output Macrocell Port and Data Bit Assignments (Table 91.)	124

μPSD325X DEVICES

Product Term Allocator	125
CPLD Output Macrocell (Figure 61.)	125
Input Macrocells (IMC)	126
Input Macrocell (Figure 62.)	126
I/O PORTS (PSD MODULE)	127
General Port Architecture	127
General I/O Port Architecture (Figure 63.)	127
Port Operating Modes	128
MCU I/O Mode	128
PLD I/O Mode	128
Address Out Mode	128
Peripheral I/O Mode	128
JTAG In-System Programming (ISP)	128
Peripheral I/O Mode (Figure 64.)	129
Port Operating Modes (Table 92.)	129
Port Operating Mode Settings (Table 93.)	129
I/O Port Latched Address Output Assignments (Table 94.)	129
Port Configuration Registers (PCR)	130
Port Configuration Registers (PCR) (Table 95.)	130
Port Pin Direction Control, Output Enable P.T. Not Defined (Table 96.)	130
Port Pin Direction Control, Output Enable P.T. Defined (Table 97.)	130
Port Direction Assignment Example (Table 98.)	130
Port Data Registers	131
Drive Register Pin Assignment (Table 99.)	131
Ports A and B – Functionality and Structure	132
Port A and Port B Structure (Figure 65.)	132
Port C – Functionality and Structure	133
Port C Structure (Figure 66.)	133
Port D – Functionality and Structure	134
Port D Structure (Figure 67.)	134
External Chip Select	135
Port D External Chip Select Signals (Figure 68.)	135
POWER MANAGEMENT	136
APD Unit (Figure 69.)	136
Enable Power-down Flow Chart (Figure 70.)	137
Power-down Mode's Effect on Ports (Table 101.)	137
PLD Power Management	138
PSD Chip Select Input (CSI, PD2)	138
Input Clock	138
Input Control Signals	138
Power Management Mode Registers PMMR01 (Table 102.)	138
Power Management Mode Registers PMMR21 (Table 103.)	139
APD Counter Operation (Table 104.)	139

RESET TIMING AND DEVICE STATUS AT RESET	140
Warm RESET	140
I/O Pin, Register and PLD Status at RESET	140
Reset of Flash Memory Erase and Program Cycles	140
Reset (RESET) Timing (Figure 71.)	140
Status During Power-on RESET, Warm RESET and Power-down Mode (Table 105.)	141
PROGRAMMING IN-CIRCUIT USING THE JTAG SERIAL INTERFACE	142
Standard JTAG Signals	142
JTAG Port Signals (Table 106.)	142
JTAG Extensions	142
Security and Flash memory Protection	142
INITIAL DELIVERY STATE	142
AC/DC PARAMETERS	143
PLD ICC /Frequency Consumption (5V range) (Figure 72.)	143
PLD ICC /Frequency Consumption (3V range) (Figure 73.)	143
PSD MODULE Example, Typ. Power Calculation at V _{CC} = 5.0V (Turbo Mode Off) (Table 107.)	144
MAXIMUM RATING	145
Absolute Maximum Ratings (Table 108.)	145
DC AND AC PARAMETERS	146
Operating Conditions (5V Devices) (Table 109.)	146
Operating Conditions (3V Devices) (Table 110.)	146
AC Symbols for Timing (Table 111.)	147
Switching Waveforms – Key (Figure 74.)	147
DC Characteristics (5V Devices) (Table 112.)	148
DC Characteristics (3V Devices) (Table 113.)	150
External Program Memory READ Cycle (Figure 75.)	152
External Program Memory AC Characteristics (with the 5V MCU Module) (Table 114.)	152
External Program Memory AC Characteristics (with the 3V MCU Module) (Table 115.)	153
External Clock Drive (with the 5V MCU Module) (Table 116.)	153
External Clock Drive (with the 3V MCU Module) (Table 117.)	153
External Data Memory READ Cycle (Figure 76.)	154
External Data Memory WRITE Cycle (Figure 77.)	154
External Data Memory AC Characteristics (with the 5V MCU Module) (Table 118.)	155
External Data Memory AC Characteristics (with the 3V MCU Module) (Table 119.)	156
A/D Analog Specification (Table 120.)	156
Input to Output Disable / Enable (Figure 78.)	157
CPLD Combinatorial Timing (5V Devices) (Table 121.)	157
CPLD Combinatorial Timing (3V Devices) (Table 122.)	157
Synchronous Clock Mode Timing – PLD (Figure 79.)	158
CPLD Macrocell Synchronous Clock Mode Timing (5V Devices) (Table 123.)	158
CPLD Macrocell Synchronous Clock Mode Timing (3V Devices) (Table 124.)	159
Asynchronous RESET / Preset (Figure 80.)	160

μPSD325X DEVICES

Asynchronous Clock Mode Timing (product term clock) (Figure 81.)	160
CPLD Macrocell Asynchronous Clock Mode Timing (5V Devices) (Table 125.)	160
CPLD Macrocell Asynchronous Clock Mode Timing (3V Devices) (Table 126.)	161
Input Macrocell Timing (product term clock) (Figure 82.)	162
Input Macrocell Timing (5V Devices) (Table 127.)	162
Input Macrocell Timing (3V Devices) (Table 128.)	162
Program, WRITE and Erase Times (5V Devices) (Table 129.)	163
Program, WRITE and Erase Times (3V Devices) (Table 130.)	163
Peripheral I/O READ Timing (Figure 83.)	164
Port A Peripheral Data Mode READ Timing (5V Devices) (Table 131.)	164
Port A Peripheral Data Mode READ Timing (3V Devices) (Table 132.)	164
Peripheral I/O WRITE Timing (Figure 84.)	165
Port A Peripheral Data Mode WRITE Timing (5V Devices) (Table 133.)	165
Port A Peripheral Data Mode WRITE Timing (3V Devices) (Table 134.)	165
Reset (RESET) Timing (Figure 85.)	166
Reset (RESET) Timing (5V Devices) (Table 135.)	166
Reset (RESET) Timing (3V Devices) (Table 136.)	166
V _{STBYON} Definitions Timing (5V Devices) (Table 137.)	166
V _{STBYON} Timing (3V Devices) (Table 138.)	166
ISC Timing (Figure 86.)	167
ISC Timing (5V Devices) (Table 139.)	167
ISC Timing (3V Devices) (Table 140.)	168
MCU Module AC Measurement I/O Waveform (Figure 87.)	168
PSD MODULE AC Float I/O Waveform (Figure 88.)	168
External Clock Cycle (Figure 89.)	169
Recommended Oscillator Circuits (Figure 90.)	169
PSD MODULE AC Measurement I/O Waveform (Figure 91.)	169
PSD MODULE AC Measurement Load Circuit (Figure 92.)	169
Capacitance (Table 141.)	169
PART NUMBERING	174
PACKAGE MECHANICAL INFORMATION	170
PART NUMBERING	174

SUMMARY DESCRIPTION

- Dual bank Flash memories
 - Concurrent operation, read from memory while erasing and writing the other. In-Application Programming (IAP) for remote updates
 - Large 128KByte or 256KByte main Flash memory for application code, operating systems, or bit maps for graphic user interfaces
 - Large 32KByte secondary Flash memory divided in small sectors. Eliminate external EEPROM with software EEPROM emulation
 - Secondary Flash memory is large enough for sophisticated communication protocol (USB) during IAP while continuing critical system tasks
- Large SRAM with battery back-up option
 - 32KByte SRAM for RTOS, high-level languages, communication buffers, and stacks
- Programmable Decode PLD for flexible address mapping of all memories
 - Place individual Flash and SRAM sectors on any address boundary
 - Built-in page register breaks restrictive 8032 limit of 64KByte address space
 - Special register swaps Flash memory segments between 8032 “program” space and “data” space for efficient In-Application Programming
- High-speed clock standard 8032 core (12-cycle)
 - 40MHz operation at 5V, 24MHz at 3.3V
 - 2 UARTs with independent baud rate, three 16-bit Timer/Counters and two External Interrupts
- USB Interface (some devices only)
 - Supports USB 1.1 Slow Mode (1.5Mbit/s)
 - Control endpoint 0 and interrupt endpoints 1 and 2
- I²C interface for peripheral connections
 - Capable of master or slave operation
- 5 Pulse Width Modulator (PWM) channels
 - Four 8-bit PWM units
 - One 8-bit PWM unit with programmable period
- 4-channel, 8-bit Analog-to-Digital Converter (ADC) with analog supply voltage (V_{REF})
- Standalone Display Data Channel (DDC)
 - For use in monitor, projector, and TV applications
 - Compliant with VESA standards DDC1 and DDC2B
 - Eliminate external DDC PROM
- Six I/O ports with up to 50 I/O pins
 - Multifunction I/O: GPIO, DDC, I²C, PWM, PLD I/O, supervisor, and JTAG
 - Eliminates need for external latches and logic
- 3000 gate PLD with 16 macrocells
 - Create glue logic, state machines, delays, etc.
 - Eliminate external PALs, PLDs, and 74HCxx
 - Simple PSDsoft Express software ...Free
- Supervisor functions
 - Generates reset upon low voltage or watchdog time-out. Eliminate external supervisor device
 - $\overline{\text{RESET}}$ Input pin; Reset output via PLD
- In-System Programming (ISP) via JTAG
 - Program entire chip in 10 - 25 seconds with no involvement of 8032
 - Allows efficient manufacturing, easy product testing, and Just-In-Time inventory
 - Eliminate sockets and pre-programmed parts
 - Program with FlashLINK™ cable and any PC
- Content Security
 - Programmable Security Bit blocks access of device programmers and readers
- Zero-Power Technology
 - Memories and PLD automatically reach standby current between input changes
- Packages
 - 52-pin TQFP
 - 80-pin TQFP: allows access to 8032 address/data/control signals for connecting to external peripherals

μPSD325X DEVICES

Table 1. μPSD325X Devices Product Matrix

Part No.	Main Flash (bit)	Sec. Flash (bit)	SRAM (bit)	Macro -Cells	I/O Pins	PWM Ch.	Timer / Ctr	UART Ch.	i ² C	ADC Ch.	DDC	USB	V _{CC}	MHz	Pins
μPSD 3254 A-40	2M	256K	256K	16	41 or 50	5	3	2	1	4	yes	yes	5V	40	52 or 80
μPSD 3254 BV-24	2M	256K	256K	16	50	5	3	2	1	4	yes		3V	24	80
μPSD 3253 B-40	1M	256K	256K	16	41	5	3	2	1	4	yes		5V	40	52
μPSD 3253 BV-24	1M	256K	256K	16	41	5	3	2	1	4	yes		3V	24	52

Figure 3. TQFP52 Connections

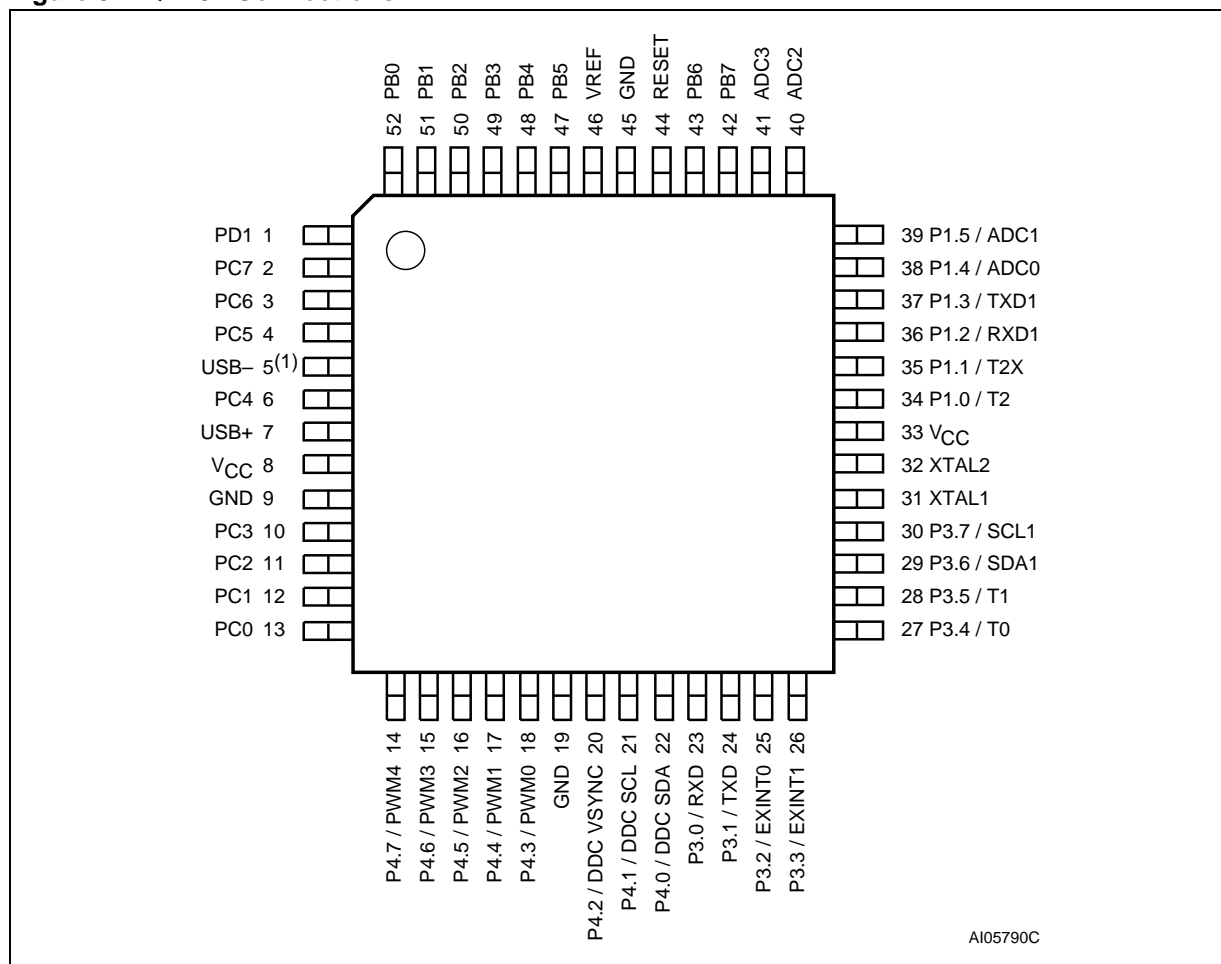

Note: 1. Pull-up resistor required on pin 5 (2kΩ for 3V devices, 7.5kΩ for 5V devices) for all 52-pin devices, with or without USB function.

Figure 4. TQFP80 Connections

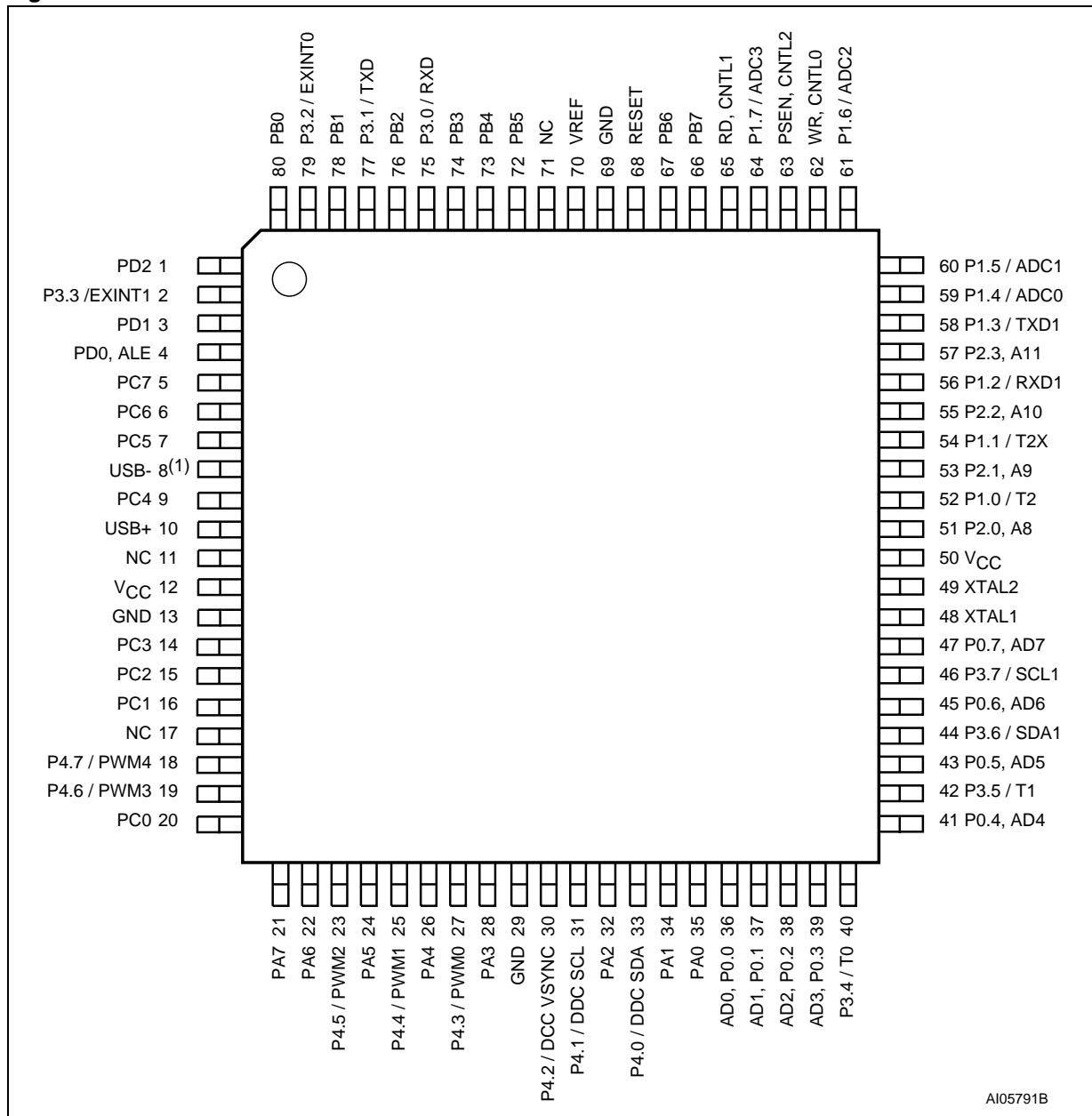

Note: NC = Not Connected

1. Pull-up resistor required on pin 8 (2kΩ for 3V devices, 7.5kΩ for 5V devices) for all 82-pin devices, with or without USB function.

μPSD325X DEVICES

Table 2. 80-Pin Package Pin Description

Port Pin	Signal Name	Pin No.	In/Out	Function	
				Basic	Alternate
P0.0	AD0	36	I/O	External Bus Multiplexed Address/Data bus A1/D1	
P0.1	AD1	37	I/O	Multiplexed Address/Data bus A0/D0	
P0.2	AD2	38	I/O	Multiplexed Address/Data bus A2/D2	
P0.3	AD3	39	I/O	Multiplexed Address/Data bus A3/D3	
P0.4	AD4	41	I/O	Multiplexed Address/Data bus A4/D4	
P0.5	AD5	43	I/O	Multiplexed Address/Data bus A5/D5	
P0.6	AD6	45	I/O	Multiplexed Address/Data bus A6/D6	
P0.7	AD7	47	I/O	Multiplexed Address/Data bus A7/D7	
P1.0	T2	52	I/O	General I/O port pin	Timer 2 Count input
P1.1	T2EX	54	I/O	General I/O port pin	Timer 2 Trigger input
P1.2	RxD2	56	I/O	General I/O port pin	2nd UART Receive
P1.3	TxD2	58	I/O	General I/O port pin	2nd UART Transmit
P1.4	ADC0	59	I/O	General I/O port pin	ADC Channel 0 input
P1.5	ADC1	60	I/O	General I/O port pin	ADC Channel 1 input
P1.6	ADC2	61	I/O	General I/O port pin	ADC Channel 2 input
P1.7	ADC3	64	I/O	General I/O port pin	ADC Channel 3 input
P2.0	A8	51	I/O	External Bus, Address A8	
P2.1	A9	53	I/O	External Bus, Address A9	
P2.2	A10	55	I/O	External Bus, Address A10	
P2.3	A11	57	I/O	External Bus, Address A11	
P3.0	RxD1	75	I/O	General I/O port pin	UART Receive
P3.1	TxD1	77	I/O	General I/O port pin	UART Transmit
P3.2	INT0	79	I/O	General I/O port pin	Interrupt 0 input / timer0 gate control
P3.3	INT1	2	I/O	General I/O port pin	Interrupt 1 input / timer1 gate control
P3.4	T0	40	I/O	General I/O port pin	Counter 0 input
P3.5	T1	42	I/O	General I/O port pin	Counter 1 input
P3.6	SDA1	44	I/O	General I/O port pin	I ² C Bus serial data I/O
P3.7	SCL1	46	I/O	General I/O port pin	I ² C Bus clock I/O
P4.0	SDA2	33	I/O	General I/O port pin	I ² C serial data I/O for DDC interface
P4.1	SCL2	31	I/O	General I/O port pin	I ² C clock I/O for DDC interface
P4.2	VSYNC	30	I/O	General I/O port pin	VSYNC input for DDC interface

Port Pin	Signal Name	Pin No.	In/Out	Function	
				Basic	Alternate
P4.3	PWM0	27	I/O	General I/O port pin	8-bit Pulse Width Modulation output 0
P4.4	PWM1	25	I/O	General I/O port pin	8-bit Pulse Width Modulation output 1
P4.5	PWM2	23	I/O	General I/O port pin	8-bit Pulse Width Modulation output 2
P4.6	PWM3	19	I/O	General I/O port pin	8-bit Pulse Width Modulation output 3
P4.7	PWM4	18	I/O	General I/O port pin	Programmable 8-bit Pulse Width modulation output 4
	USB-	8	I/O	USB Pin Pull-up resistor required (2kΩ for 3V devices, 7.5kΩ for 5V devices) for all devices, with or without USB function.	
	USB+	10	I/O	USB Pin	
	AVREF	70	O	Reference Voltage input for ADC	
	RD_	65	O	READ signal, external bus	
	WR_	62	O	WRITE signal, external bus	
	PSEN_	63	O	$\overline{\text{PSEN}}$ signal, external bus	
	ALE	4	O	Address Latch signal, external bus	
	RESET_	68	I	Active low $\overline{\text{RESET}}$ input	
	XTAL1	48	I	Oscillator input pin for system clock	
	XTAL2	49	O	Oscillator output pin for system clock	
PA0		35	I/O	General I/O port pin	1. PLD Macro-cell outputs 2. PLD inputs 3. Latched Address Out (A0-A7) 4. Peripheral I/O Mode
PA1		34	I/O	General I/O port pin	
PA2		32	I/O	General I/O port pin	
PA3		28	I/O	General I/O port pin	
PA4		26	I/O	General I/O port pin	
PA5		24	I/O	General I/O port pin	
PA6		22	I/O	General I/O port pin	
PA7		21	I/O	General I/O port pin	

μPSD325X DEVICES

Port Pin	Signal Name	Pin No.	In/Out	Function	
				Basic	Alternate
PB0		80	I/O	General I/O port pin	1. PLD Macro-cell outputs 2. PLD inputs 3. Latched Address Out (A0-A7)
PB1		78	I/O	General I/O port pin	
PB2		76	I/O	General I/O port pin	
PB3		74	I/O	General I/O port pin	
PB4		73	I/O	General I/O port pin	
PB5		72	I/O	General I/O port pin	
PB6		67	I/O	General I/O port pin	
PB7		66	I/O	General I/O port pin	
PC0	TMS	20	I	JTAG pin	1. PLD Macro-cell outputs 2. PLD inputs 3. SRAM stand by voltage input (VSTBY) 4. SRAM battery-on indicator (PC4) 5. JTAG pins are dedicated pins
PC1	TCK	16	I	JTAG pin	
PC2	VSTBY	15	I/O	General I/O port pin	
PC3	TSTAT	14	I/O	General I/O port pin	
PC4	TERR	9	I/O	General I/O port pin	
PC5	TDI	7	I	JTAG pin	
PC6	TDO	6	O	JTAG pin	
PC7		5	I/O	General I/O port pin	
PD1	CLKIN	3	I/O	General I/O port pin	1. PLD I/O 2. Clock input to PLD and APD
PD2	CSI	1	I/O	General I/O port pin	1. PLD I/O 2. Chip select to PSD Module
Vcc		12			
Vcc		50			
GND		13			
GND		29			
GND		69			
NC		11			
NC		17			
NC		71			

52 PIN PACKAGE I/O PORT

The 52-pin package members of the μPSD325X devices have the same port pins as those of the 80-pin package except:

- Port 0 (P0.0-P0.7, external address/data bus AD0-AD7)
- Port 2 (P2.0-P2.3, external address bus A8-A11)
- Port A (PA0-PA7)
- Port D (PD2)
- Bus control signal (RD,WR,PSEN,ALE)

Pin 5 requires a pull-up resistor (2kΩ for 3V devices, 7.5kΩ for 5V devices) for all devices, with or without USB function.

ARCHITECTURE OVERVIEW

Memory Organization

The μPSD325X devices' standard 8032 Core has separate 64KB address spaces for Program memory and Data Memory. Program memory is where the 8032 executes instructions from. Data memory is used to hold data variables. Flash memory can be mapped in either program or data space. The Flash memory consists of two flash memory blocks: the main Flash (1 or 2Mbit) and the Secondary Flash (256Kbit). Except during flash memory programming or update, Flash memory can only be read, not written to. A Page Register is used to access memory beyond the 64K bytes address space. Refer to the PSD Module for details on mapping of the Flash memory.

The 8032 core has two types of data memory (internal and external) that can be read and written. The internal SRAM consists of 256 bytes, and includes the stack area.

The SFR (Special Function Registers) occupies the upper 128 bytes of the internal SRAM, the registers can be accessed by Direct addressing only. There are two separate blocks of external SRAM inside the μPSD325X devices: one 256 bytes is assigned for DDC data storage. Another 32K bytes resides in the PSD Module that can be mapped to any address space defined by the user.

Figure 5. Memory Map and Address Space

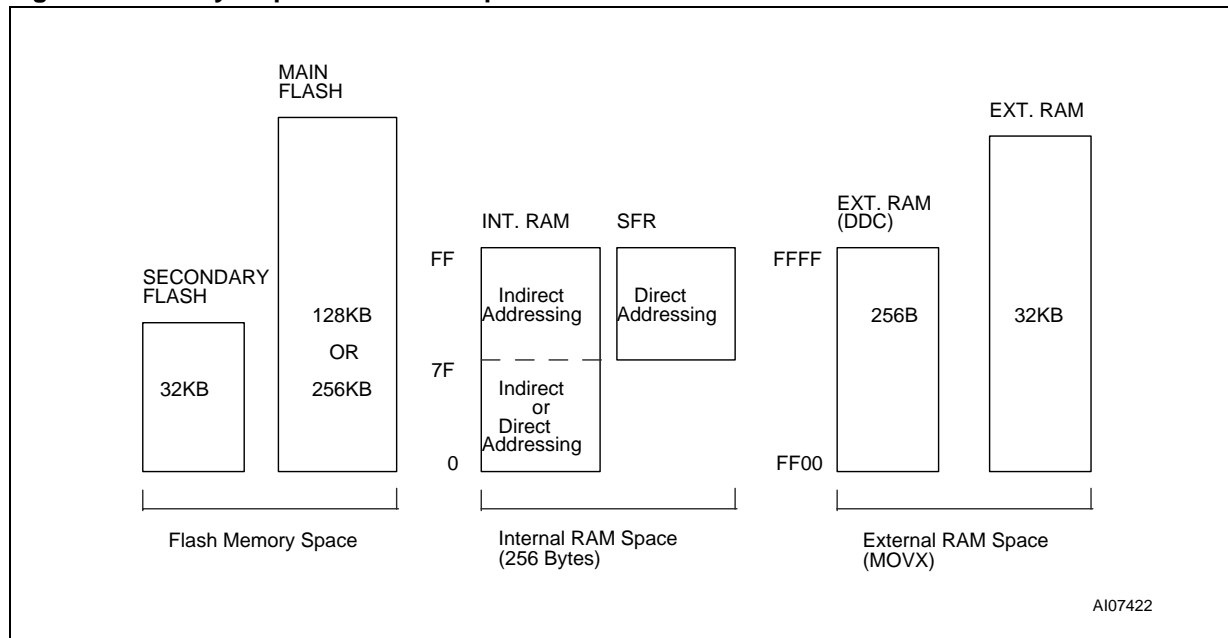

Registers

The 8032 has several registers; these are the Program Counter (PC), Accumulator (A), B Register (B), the Stack Pointer (SP), the Program Status Word (PSW), General purpose registers (R0 to R7), and DPTR (Data Pointer register).

Figure 6. 8032 MCU Registers

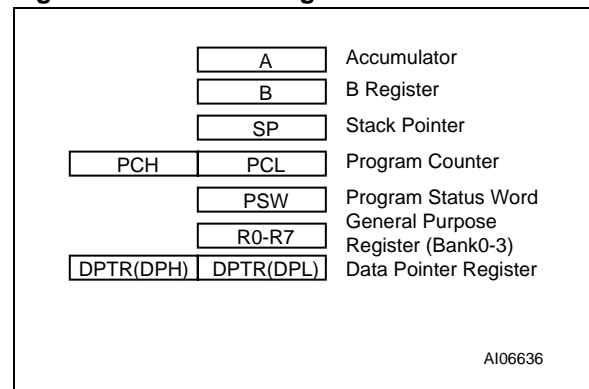

Accumulator. The Accumulator is the 8-bit general purpose register, used for data operation such as transfer, temporary saving, and conditional tests. The Accumulator can be used as a 16-bit register with B Register as shown below.

Figure 7. Configuration of BA 16-bit Registers

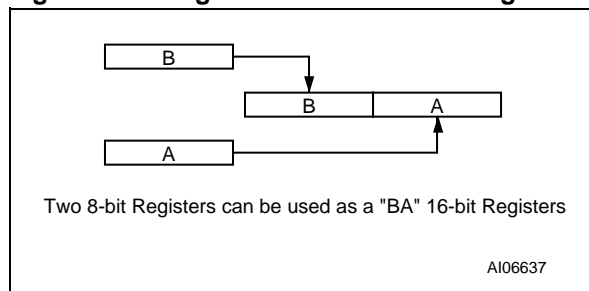

B Register. The B Register is the 8-bit general purpose register, used for an arithmetic operation such as multiply, division with Accumulator

Stack Pointer. The Stack Pointer Register is 8 bits wide. It is incremented before data is stored during PUSH and CALL executions. While the stack may reside anywhere in on-chip RAM, the Stack Pointer is initialized to 07h after reset. This causes the stack to begin at location 08h.

Figure 8. Stack Pointer

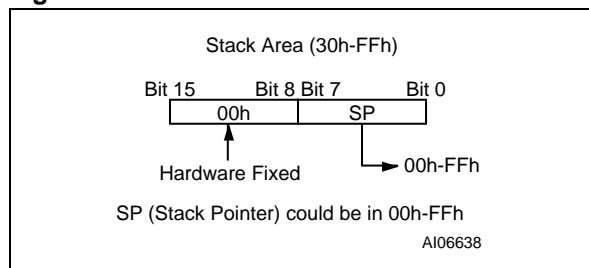

Program Counter. The Program Counter is a 16-bit wide which consists of two 8-bit registers, PCH and PCL. This counter indicates the address of the next instruction to be executed. In **RESET** state, the program counter has reset routine address (PCH:00h, PCL:00h).

Program Status Word. The Program Status Word (PSW) contains several bits that reflect the current state of the CPU and select Internal RAM (00h to 1Fh: Bank0 to Bank3). The PSW is described in Figure 9, page 19. It contains the Carry flag, the Auxiliary carry flag, the Half Carry (for BCD operation), the general purpose flag, the Register bank select flags, the Overflow flag, and Parity flag.

[Carry Flag, CY]. This flag stores any carry or not borrow from the ALU of CPU after an arithmetic operation and is also changed by the Shift Instruction or Rotate Instruction.

[Auxiliary Carry Flag, AC]. After operation, this is set when there is a carry from Bit 3 of ALU or there is no borrow from Bit 4 of ALU.

[Register Bank Select Flags, RS0, RS1]. This flags select one of four bank(00~07H:bank0, 08~0Fh:bank1, 10~17h:bank2, 17~1Fh:bank3) in Internal RAM.

[Overflow Flag, OV]. This flag is set to '1' when an overflow occurs as the result of an arithmetic operation involving signs. An overflow occurs when the result of an addition or subtraction exceeds +127 (7Fh) or -128 (80h). The CLR V instruction clears the overflow flag. There is no set instruction. When the BIT instruction is executed, Bit 6 of memory is copied to this flag.

[Parity Flag, P]. This flag reflect on number of Accumulator's 1. If number of Accumulator's 1 is odd, P=0. otherwise P=1. Sum of adding Accumulator's 1 to P is always even.

R0~R7. General purpose 8-bit registers that are locked in the lower portion of internal data area.

Data Pointer Register. Data Pointer Register is 16-bit wide which consists of two-8bit registers, DPH and DPL. This register is used as a data pointer for the data transmission with external data memory in the PSD Module.

Figure 9. PSW (Program Status Word) Register

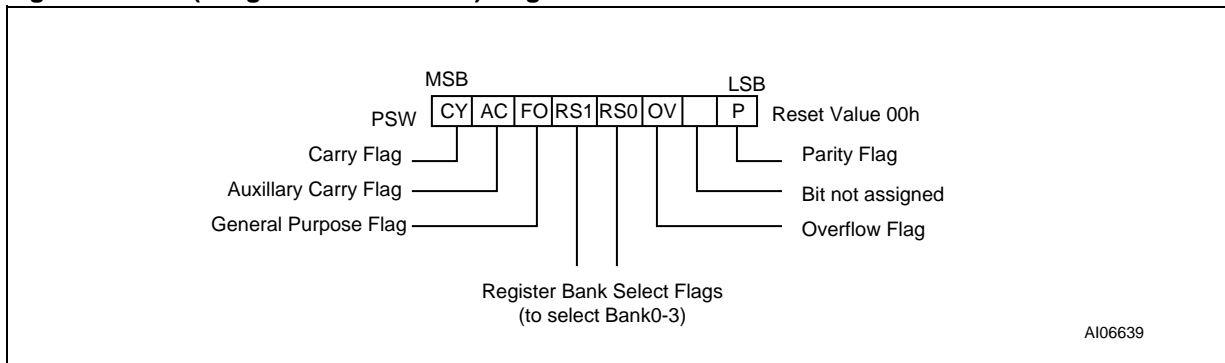

Program Memory

The program memory consists of two Flash memory: 128 KByte (or 256 KByte) Main Flash and 32 KByte of Secondary Flash. The Flash memory can be mapped to any address space as defined by the user in the PSDsoft Tool. It can also be mapped to Data memory space during Flash memory update or programming.

After reset, the CPU begins execution from location 0000h. As shown in Figure 10, each interrupt is assigned a fixed location in Program Memory. The interrupt causes the CPU to jump to that location, where it commences execution of the service routine. External Interrupt 0, for example, is assigned to location 0003h. If External Interrupt 0 is going to be used, its service routine must begin at location 0003h. If the interrupt is not going to be used, its service location is available as general purpose Program Memory.

The interrupt service locations are spaced at 8-byte intervals: 0003h for External Interrupt 0, 000Bh for Timer 0, 0013h for External Interrupt 1, 001Bh for Timer 1 and so forth. If an interrupt service routine is short enough (as is often the case in control applications), it can reside entirely within that 8-byte interval. Longer service routines can use a jump instruction to skip over subsequent interrupt locations, if other interrupts are in use.

Data memory

The internal data memory is divided into four physically separated blocks: 256 bytes of internal RAM, 128 bytes of Special Function Registers (SFRs) areas, 256 bytes of external RAM (XRAM-DDC) and 32K bytes (XRAM-PSD) in the PSD Module.

RAM

Four register banks, each 8 registers wide, occupy locations 0 through 31 in the lower RAM area. Only one of these banks may be enabled at a time. The next 16 bytes, locations 32 through 47, contain 128 directly addressable bit locations. The stack depth is only limited by the available internal RAM space of 256 bytes.

Figure 10. Interrupt Location of Program Memory

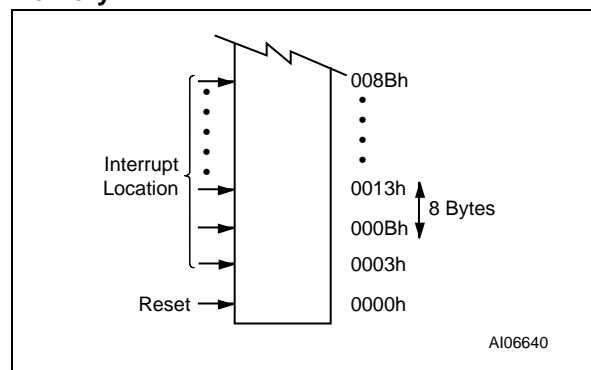

XRAM-DDC

The 256 bytes of XRAM-DDC used to support DDC interface is also available for system usage by indirect addressing through the address pointer DDCADR and data I/O buffer RAMBUF. The address pointer (DDCADR) is equipped with the post increment capability to facilitate the transfer of data in bulk (for details refer to DDC Interface part). However, it is also possible to address the RAM through MOVX command as normally used in the internal RAM extension of 80C51 derivatives. XRAM-DDC FF00 to FFFF is directly addressable as external data memory locations FF00 to FFFF via MOVX-DPTR instruction or via MOVX-Ri instruction. When XRAM-DDC is disabled, the address space FF00 to FFFF can be assigned to other resources.

XRAM-PSD

The 32K bytes of XRAM-PSD resides in the PSD Module and can be mapped to any address space through the DPLD (Decoding PLD) as defined by the user in PSDsoft Development tool. The XRAM-PSD has a battery backup feature that allow the data to be retained in the event of a power lost. The battery is connected to the Port C PC2 pin. This pin must be configured in PSDSoft to be battery back-up.

SFR

The SFRs can only be addressed directly in the address range from 80h to FFh. Table 15, page 32 gives an overview of the Special Function Registers. Sixteen address in the SFRs space are both-byte and bit-addressable. The bit-addressable SFRs are those whose address ends in 0h and 8h. The bit addresses in this area are 80h to FFh.

Table 3. RAM Address

↓	Byte Address (in Hexadecimal)	Bit Address (Hex)								Byte Address (in Decimal)	↓
		msb							lsb		
	FFh									255	
	30h									48	
	2Fh	7F	7E	7D	7C	7B	7A	79	78	47	
	2Eh	77	76	75	74	73	72	71	70	46	
	2Dh	6F	6E	6D	6C	6B	6A	69	68	45	
	2Ch	67	66	65	64	63	62	61	60	44	
	2Bh	5F	5E	5D	5C	5B	5A	59	58	43	
	2Ah	57	56	55	54	53	52	51	50	42	
	29h	4F	4E	4D	4C	4B	4A	49	48	41	
	28h	47	46	45	44	43	42	41	40	40	
	27h	3F	3E	3D	3C	3B	3A	39	38	39	
	26h	37	36	35	34	33	32	31	30	38	
	25h	2F	2E	2D	2C	2B	2A	29	28	37	
	24h	27	26	25	24	23	22	21	20	36	
	23h	1F	1E	1D	1C	1B	1A	19	18	35	
	22h	17	16	15	14	13	12	11	10	34	
	21h	0F	0E	0D	0C	0B	0A	09	08	33	
	20h	07	06	05	04	03	02	01	00	32	
	1Fh	Register Bank 3								31	
	18h	Register Bank 2								24	
	17h	Register Bank 2								23	
	10h	Register Bank 1								16	
	0Fh	Register Bank 1								15	
	08h	Register Bank 0								8	
	07h	Register Bank 0								7	
	00h	Register Bank 0								0	

Addressing Modes

The addressing modes in μPSD325X devices instruction set are as follows

- Direct addressing
- Indirect addressing
- Register addressing
- Register-specific addressing
- Immediate constants addressing
- Indexed addressing

(1) Direct addressing. In a direct addressing the operand is specified by an 8-bit address field in the instruction. Only internal Data RAM and SFRs (80~FFH RAM) can be directly addressed.

Example:

```
mov A, 3EH ; A <----- RAM[3E]
```

Figure 11. Direct Addressing

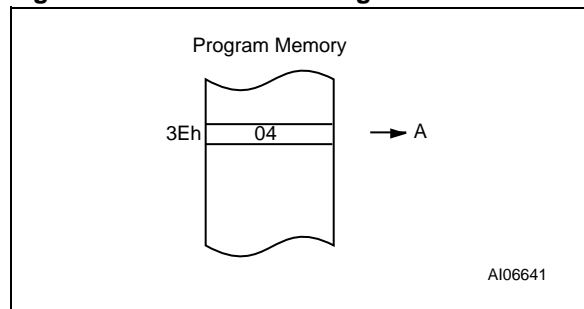

(2) Indirect addressing. In indirect addressing the instruction specifies a register which contains the address of the operand. Both internal and external RAM can be indirectly addressed. The address register for 8-bit addresses can be R0 or R1 of the selected register bank, or the Stack Pointer. The address register for 16-bit addresses can only be the 16-bit “data pointer” register, DPTR.

Example:

```
mov @R1, #40 H ;[R1] <-----40H
```

Figure 12. Indirect Addressing

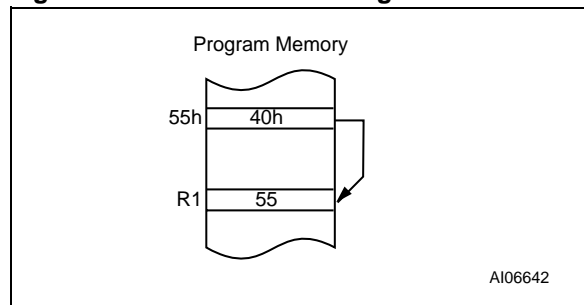

(3) Register addressing. The register banks, containing registers R0 through R7, can be accessed by certain instructions which carry a 3-bit register specification within the opcode of the instruction. Instructions that access the registers this way are code efficient, since this mode eliminates an address byte. When the instruction is executed, one of four banks is selected at execution time by the two bank select bits in the PSW.

Example:

```
mov PSW, #0001000B ; select Bank0
mov A, #30H
mov R1, A
```

(4) Register-specific addressing. Some instructions are specific to a certain register. For example, some instructions always operate on the Accumulator, or Data Pointer, etc., so no address byte is needed to point it. The opcode itself does that.

(5) Immediate constants addressing. The value of a constant can follow the opcode in Program memory.

Example:

```
mov A, #10H.
```

(6) Indexed addressing. Only Program memory can be accessed with indexed addressing, and it can only be read. This addressing mode is intended for reading look-up tables in Program memory. A 16-bit base register (either DPTR or PC) points to the base of the table, and the Accumulator is set up with the table entry number. The address of the table entry in Program memory is formed by adding the Accumulator data to the base pointer.

Example:

```
movc A, @A+DPTR
```

Figure 13. Indexed Addressing

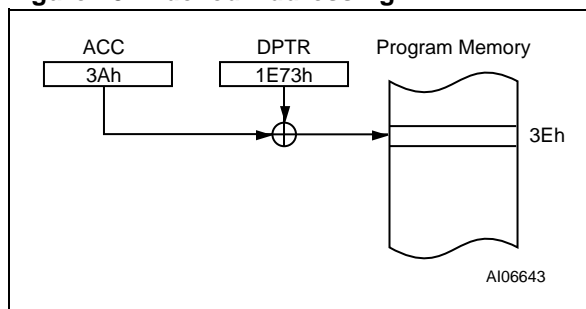

Arithmetic Instructions

The arithmetic instructions is listed in Table 4, page 22. The table indicates the addressing modes that can be used with each instruction to access the <byte> operand. For example, the ADD A, <byte> instruction can be written as:

```
ADD a, 7FH (direct addressing)
ADD A, @R0 (indirect addressing)
ADD a, R7 (register addressing)
ADD A, #127 (immediate constant)
```

Note: Any byte in the internal Data Memory space can be incremented without going through the Accumulator.

One of the INC instructions operates on the 16-bit Data Pointer. The Data Pointer is used to generate 16-bit addresses for external memory, so being able to increment it in one 16-bit operations is a useful feature.

The MUL AB instruction multiplies the Accumulator by the data in the B register and puts the 16-bit product into the concatenated B and Accumulator registers.

The DIV AB instruction divides the Accumulator by the data in the B register and leaves the 8-bit quotient in the Accumulator, and the 8-bit remainder in the B register.

In shift operations, dividing a number by 2ⁿ shifts its “n” bits to the right. Using DIV AB to perform the division completes the shift in 4’s and leaves the B register holding the bits that were shifted out. The DAA instruction is for BCD arithmetic operations. In BCD arithmetic, ADD and ADDC instructions should always be followed by a DAA operation, to ensure that the result is also in BCD.

Note: DAA will not convert a binary number to BCD. The DAA operation produces a meaningful result only as the second step in the addition of two BCD bytes.

Table 4. Arithmetic Instructions

Mnemonic	Operation	Addressing Modes			
		Dir.	Ind.	Reg.	Imm
ADD A,<byte>	$A = A + \text{<byte>}$	X	X	X	X
ADDC A,<byte>	$A = A + \text{<byte>} + C$	X	X	X	X
SUBB A,<byte>	$A = A - \text{<byte>} - C$	X	X	X	X
INC	$A = A + 1$	Accumulator only			
INC <byte>	$\text{<byte>} = \text{<byte>} + 1$	X	X	X	
INC DPTR	$DPTR = DPTR + 1$	Data Pointer only			
DEC	$A = A - 1$	Accumulator only			
DEC <byte>	$\text{<byte>} = \text{<byte>} - 1$	X	X	X	
MUL AB	$B:A = B \times A$	Accumulator and B only			
DIV AB	$A = \text{Int}[A / B]$ $B = \text{Mod}[A / B]$	Accumulator and B only			
DA A	Decimal Adjust	Accumulator only			

Logical Instructions

Table 5, page 23 shows list of μPSD325X devices logical instructions. The instructions that perform Boolean operations (AND, OR, Exclusive OR, NOT) on bytes perform the operation on a bit-by-bit basis. That is, if the Accumulator contains 00110101B and byte contains 01010011B, then:

```
ANL A, <byte>
```

will leave the Accumulator holding 00010001B.

The addressing modes that can be used to access the <byte> operand are listed in Table 5.

The ANL A, <byte> instruction may take any of the forms:

- ANL A,7FH(direct addressing)
- ANL A, @R1 (indirect addressing)
- ANL A,R6 (register addressing)
- ANL A,#53H (immediate constant)

Note: Boolean operations can be performed on any byte in the internal Data Memory space without going through the Accumulator. The XRL <byte>, #data instruction, for example, offers a quick and easy way to invert port bits, as in XRL P1, #0FFH.

If the operation is in response to an interrupt, not using the Accumulator saves the time and effort to push it onto the stack in the service routine.

The Rotate instructions (RL A, RLC A, etc.) shift the Accumulator 1 bit to the left or right. For a left rotation, the MSB rolls into the LSB position. For a right rotation, the LSB rolls into the MSB position.

The SWAP A instruction interchanges the high and low nibbles within the Accumulator. This is a useful operation in BCD manipulations. For example, if the Accumulator contains a binary number which is known to be less than 100, it can be quickly converted to BCD by the following code:

```
MOVE B,#10
DIV AB
SWAP A
ADD A,B
```

Dividing the number by 10 leaves the tens digit in the low nibble of the Accumulator, and the ones digit in the B register. The SWAP and ADD instructions move the tens digit to the high nibble of the Accumulator, and the ones digit to the low nibble.



Table 5. Logical Instructions

Mnemonic	Operation	Addressing Modes			
		Dir.	Ind.	Reg.	Imm
ANL A,<byte>	A = A .AND. <byte>	X	X	X	X
ANL <byte>,A	A = <byte> .AND. A	X			
ANL <byte>,#data	A = <byte> .AND. #data	X			
ORL A,<byte>	A = A .OR. <byte>	X	X	X	X
ORL <byte>,A	A = <byte> .OR. A	X			
ORL <byte>,#data	A = <byte> .OR. #data	X			
XRL A,<byte>	A = A .XOR. <byte>	X	X	X	X
XRL <byte>,A	A = <byte> .XOR. A	X			
XRL <byte>,#data	A = <byte> .XOR. #data	X			
CRL A	A = 00h	Accumulator only			
CPL A	A = .NOT. A	Accumulator only			
RL A	Rotate A Left 1 bit	Accumulator only			
RLC A	Rotate A Left through Carry	Accumulator only			
RR A	Rotate A Right 1 bit	Accumulator only			
RRC A	Rotate A Right through Carry	Accumulator only			
SWAP A	Swap Nibbles in A	Accumulator only			

Data Transfers

Internal RAM. Table 6 shows the menu of instructions that are available for moving data around within the internal memory spaces, and the addressing modes that can be used with each one. The MOV <dest>, <src> instruction allows data to be transferred between any two internal RAM or SFR locations without going through the Accumulator. Remember, the Upper 128 bytes of data RAM can be accessed only by indirect addressing, and SFR space only by direct addressing.

Note: In μPSD325X devices, the stack resides in on-chip RAM, and grows upwards. The PUSH instruction first increments the Stack Pointer (SP), then copies the byte into the stack. PUSH and POP use only direct addressing to identify the byte being saved or restored, but the stack itself is accessed by indirect addressing using the SP register. This means the stack can go into the Upper 128 bytes of RAM, if they are implemented, but not into SFR space.

The Data Transfer instructions include a 16-bit MOV that can be used to initialize the Data Pointer (DPTR) for look-up tables in Program Memory.

The XCH A, <byte> instruction causes the Accumulator and ad-dressed byte to exchange data. The XCHD A, @Ri instruction is similar, but only the low nibbles are involved in the exchange. To see how XCH and XCHD can be used to facilitate data manipulations, consider first the problem of shifting and 8-digit BCD number two digits to the right. Table 8 shows how this can be done using XCH instructions. To aid in understanding how the code works, the contents of the registers that are holding the BCD number and the content of the Accumulator are shown alongside each instruction to indicate their status after the instruction has been executed.

After the routine has been executed, the Accumulator contains the two digits that were shifted out on the right. Doing the routine with direct MOVs uses 14 code bytes. The same operation with XCHs uses only 9 bytes and executes almost twice as fast. To right-shift by an odd number of digits, a one-digit must be executed. Table 9 shows a sample of code that will right-shift a BCD number one digit, using the XCHD instruction. Again, the contents of the registers holding the number and of the accumulator are shown alongside each instruction.

Table 6. Data Transfer Instructions that Access Internal Data Memory Space

Mnemonic	Operation	Addressing Modes			
		Dir.	Ind.	Reg.	Imm
MOV A,<src>	A = <src>	X	X	X	X
MOV <dest>,A	<dest> = A	X	X	X	
MOV <dest>,<src>	<dest> = <src>	X	X	X	X
MOV DPTR,#data16	DPTR = 16-bit immediate constant				X
PUSH <src>	INC SP; MOV “@SP”,<src>	X			
POP <dest>	MOV <dest>,”@SP”; DEC SP	X			
XCH A,<byte>	Exchange contents of A and <byte>	X	X	X	
XCHD A,@Ri	Exchange low nibbles of A and @Ri		X		



First, pointers R1 and R0 are set up to point to the two bytes containing the last four BCD digits. Then a loop is executed which leaves the last byte, location 2EH, holding the last two digits of the shifted number. The pointers are decremented, and the loop is repeated for location 2DH. The CJNE instruction (Compare and Jump if Not equal) is a loop control that will be described later. The loop executed from LOOP to CJNE for R1 = 2EH, 2DH, 2CH, and 2BH. At that point the digit that was originally shifted out on the right has propagated to location 2AH. Since that location should be left with 0s, the lost digit is moved to the Accumulator.

Table 7. Shifting a BCD Number Two Digits to the Right (using direct MOVs: 14 bytes)

		2A	2B	2C	2D	2E	ACC
MOV	A,2Eh	00	12	34	56	78	78
MOV	2Eh,2Dh	00	12	34	56	56	78
MOV	2Dh,2Ch	00	12	34	34	56	78
MOV	2Ch,2Bh	00	12	12	34	56	78
MOV	2Bh,#0	00	00	12	34	56	78

Table 8. Shifting a BCD Number Two Digits to the Right (using direct XCHs: 9 bytes)

		2A	2B	2C	2D	2E	ACC
CLR	A	00	12	34	56	78	00
XCH	A,2Bh	00	00	34	56	78	12
XCH	A,2Ch	00	00	12	56	78	34
XCH	A,2Dh	00	00	12	34	78	56
XCH	A,2Eh	00	00	12	34	56	78

Table 9. Shifting a BCD Number One Digit to the Right

		2A	2B	2C	2D	2E	ACC
MOV	R1,#2Eh	00	12	34	56	78	xx
MOV	R0,#2Dh	00	12	34	56	78	xx
	; loop for R1 = 2Eh						
LOOP:	MOV A,@R1	00	12	34	56	78	78
	XCHD A,@R0	00	12	34	58	78	76
	SWAP A	00	12	34	58	78	67
	MOV @R1,A	00	12	34	58	67	67
	DEC R1	00	12	34	58	67	67
	DEC R0	00	12	34	58	67	67
	CNJE R1,#2Ah,LOOP	00	12	34	58	67	67
	; loop for R1 = 2Dh	00	12	38	45	67	45
	; loop for R1 = 2Ch	00	18	23	45	67	23
	; loop for R1 = 2Bh	08	01	23	45	67	01
	CLR A	08	01	23	45	67	00
	XCH A,2Ah	00	01	23	45	67	08

External RAM. Table 10 shows a list of the Data Transfer instructions that access external Data Memory. Only indirect addressing can be used. The choice is whether to use a one-byte address, @Ri, where Ri can be either R0 or R1 of the selected register bank, or a two-byte address, @DTPR.

Note: In all external Data RAM accesses, the Accumulator is always either the destination or source of the data.

Lookup Tables. Table 11 shows the two instructions that are available for reading lookup tables in Program Memory. Since these instructions access only Program Memory, the lookup tables can only be read, not updated.

The mnemonic is MOVC for “move constant.” The first MOVC instruction in Table 11 can accommodate a table of up to 256 entries numbered 0 through 255. The number of the desired entry is loaded into the Accumulator, and the Data Pointer is set up to point to the beginning of the table. Then:

```
MOVC A, @A+DPTR
```

copies the desired table entry into the Accumulator.

The other MOVC instruction works the same way, except the Program Counter (PC) is used as the table base, and the table is accessed through a subroutine. First the number of the desired entry is loaded into the Accumulator, and the subroutine is called:

```
MOV A, ENTRY NUMBER
CALL TABLE
```

The subroutine “TABLE” would look like this:

```
TABLE: MOVC A, @A+PC
RET
```

The table itself immediately follows the RET (return) instruction in Program Memory. This type of table can have up to 255 entries, numbered 1 through 255. Number 0 cannot be used, because at the time the MOVC instruction is executed, the PC contains the address of the RET instruction. An entry numbered 0 would be the RET opcode itself.

Table 10. Data Transfer Instruction that Access External Data Memory Space

Address Width	Mnemonic	Operation
8 bits	MOVX A, @Ri	READ external RAM @Ri
8 bits	MOVX @Ri, A	WRITE external RAM @Ri
16 bits	MOVX A, @DPTR	READ external RAM @DPTR
16 bits	MOVX @DPTR, a	WRITE external RAM @DPTR

Table 11. Lookup Table READ Instruction

Mnemonic	Operation
MOVC A, @A+DPTR	READ program memory at (A+DPTR)
MOVC A, @A+PC	READ program memory at (A+PC)



Boolean Instructions

The µPSD325X devices contain a complete Boolean (single-bit) processor. One page of the internal RAM contains 128 address-able bits, and the SFR space can support up to 128 addressable bits as well. All of the port lines are bit-addressable, and each one can be treated as a separate single-bit port. The instructions that access these bits are not just conditional branches, but a complete menu of move, set, clear, complement, OR and AND instructions. These kinds of bit operations are not easily obtained in other architectures with any amount of byte-oriented software.

The instruction set for the Boolean processor is shown in Table 12. All bits accesses are by direct addressing.

Bit addresses 00h through 7Fh are in the Lower 128, and bit addresses 80h through FFh are in SFR space.

Note how easily an internal flag can be moved to a port pin:

```
MOV C,FLAG
MOV P1.0,C
```

In this example, FLAG is the name of any addressable bit in the Lower 128 or SFR space. An I/O line (the LSB of Port 1, in this case) is set or cleared depending on whether the Flag Bit is '1' or '0.'

The Carry Bit in the PSW is used as the single-bit Accumulator of the Boolean processor. Bit instructions that refer to the Carry Bit as C assemble as Carry-specific instructions (CLR C, etc.). The Carry Bit also has a direct address, since it resides in the PSW register, which is bit-addressable.

Note: The Boolean instruction set includes ANL and ORL operations, but not the XRL (Exclusive OR) operation. An XRL operation is simple to implement in software. Suppose, for example, it is required to form the Exclusive OR of two bits:

```
C = bit 1 .XRL. bit2
```

The software to do that could be as follows:

```
MOV C , bit1
JNB bit2, OVER
CPL C
OVER: (continue)
```

First, Bit 1 is moved to the Carry. If bit2 = 0, then C now contains the correct result. That is, Bit 1 .XRL. bit2 = bit1 if bit2 = 0. On the other hand, if bit2 = 1, C now contains the complement of the correct result. It need only be inverted (CPL C) to complete the operation.

This code uses the JNB instruction, one of a series of bit-test instructions which execute a jump if the

addressed bit is set (JC, JB, JBC) or if the addressed bit is not set (JNC, JNB). In the above case, Bit 2 is being tested, and if bit2 = 0, the CPL C instruction is jumped over.

JBC executes the jump if the addressed bit is set, and also clears the bit. Thus a flag can be tested and cleared in one operation. All the PSW bits are directly addressable, so the Parity Bit, or the general-purpose flags, for example, are also available to the bit-test instructions.

Table 12. Boolean Instructions

Mnemonic	Operation
ANL C,bit	C = A .AND. bit
ANL C,/bit	C = C .AND. .NOT. bit
ORL C,bit	C = A .OR. bit
ORL C,/bit	C = C .OR. .NOT. bit
MOV C,bit	C = bit
MOV bit,C	bit = C
CLR C	C = 0
CLR bit	bit = 0
SETB C	C = 1
SETB bit	bit = 1
CPL C	C = .NOT. C
CPL bit	bit = .NOT. bit
JC rel	Jump if C =1
JNC rel	Jump if C = 0
JB bit,rel	Jump if bit =1
JNB bit,rel	Jump if bit = 0
JBC bit,rel	Jump if bit = 1; CLR bit

Relative Offset

The destination address for these jumps is specified to the assembler by a label or by an actual address in Program memory. However, the destination address assembles to a relative offset byte. This is a signed (two's complement) offset byte which is added to the PC in two's complement arithmetic if the jump is executed.

The range of the jump is therefore -128 to +127 Program Memory bytes relative to the first byte following the instruction.

Jump Instructions

Table 13 shows the list of unconditional jump instructions. The table lists a single “JMP addr” instruction, but in fact there are three SJMP, LJMP, and AJMP, which differ in the format of the destination address. JMP is a generic mnemonic which can be used if the programmer does not care which way the jump is en-coded.

The SJMP instruction encodes the destination address as a relative offset, as described above. The instruction is 2 bytes long, consisting of the opcode and the relative offset byte. The jump distance is limited to a range of -128 to +127 bytes relative to the instruction following the SJMP.

The LJMP instruction encodes the destination address as a 16-bit constant. The instruction is 3 bytes long, consisting of the opcode and two address bytes. The destination address can be anywhere in the 64K Program Memory space.

The AJMP instruction encodes the destination address as an 11-bit constant. The instruction is 2 bytes long, consisting of the opcode, which itself contains 3 of the 11 address bits, followed by another byte containing the low 8 bits of the destination address. When the instruction is executed, these 11 bits are simply substituted for the low 11 bits in the PC. The high 5 bits stay the same. Hence the destination has to be within the same 2K block as the instruction following the AJMP.

In all cases the programmer specifies the destination address to the assembler in the same way: as a label or as a 16-bit constant. The assembler will put the destination address into the correct format for the given instruction. If the format required by the instruction will not support the distance to the specified destination address, a “Destination out of range” message is written into the List file.

The JMP @A+DPTR instruction supports case jumps. The destination address is computed at execution time as the sum of the 16-bit DPTR register and the Accumulator. Typically, DPTR is set up with the address of a jump table. In a 5-way branch, for ex-ample, an integer 0 through 4 is loaded into the Accumulator. The code to be executed might be as follows:

```
MOV DPTR,#JUMP TABLE
MOV A,INDEX_NUMBER
RL A
JMP @A+DPTR
```

The RL A instruction converts the index number (0 through 4) to an even number on the range 0 through 8, because each entry in the jump table is 2 bytes long:

```
JUMP TABLE:
AJMP CASE 0
AJMP CASE 1
AJMP CASE 2
AJMP CASE 3
AJMP CASE 4
```

Table 13 shows a single “CALL addr” instruction, but there are two of them, LCALL and ACALL, which differ in the format in which the subroutine address is given to the CPU. CALL is a generic mnemonic which can be used if the programmer does not care which way the address is encoded.

The LCALL instruction uses the 16-bit address format, and the subroutine can be anywhere in the 64K Program Memory space. The ACALL instruction uses the 11-bit format, and the subroutine must be in the same 2K block as the instruction following the ACALL.

In any case, the programmer specifies the subroutine address to the assembler in the same way: as a label or as a 16-bit constant. The assembler will put the address into the correct format for the given instructions.

Subroutines should end with a RET instruction, which returns execution to the instruction following the CALL.

RETI is used to return from an interrupt service routine. The only difference between RET and RETI is that RETI tells the interrupt control system that the interrupt in progress is done. If there is no interrupt in progress at the time RETI is executed, then the RETI is functionally identical to RET.

Table 13. Unconditional Jump Instructions

Mnemonic	Operation
JMP addr	Jump to addr
JMP @A+DPTR	Jump to A+DPTR
CALL addr	Call Subroutine at addr
RET	Return from subroutine
RETI	Return from interrupt
NOP	No operation



Table 14 shows the list of conditional jumps available to the μPSD325X device user. All of these jumps specify the destination address by the relative offset method, and so are limited to a jump distance of -128 to +127 bytes from the instruction following the conditional jump instruction. Important to note, however, the user specifies to the assembler the actual destination address the same way as the other jumps: as a label or a 16-bit constant.

There is no Zero Bit in the PSW. The JZ and JNZ instructions test the Accumulator data for that condition.

The DJNZ instruction (Decrement and Jump if Not Zero) is for loop control. To execute a loop N times, load a counter byte with N and terminate the loop with a DJNZ to the beginning of the loop, as shown below for N = 10:

```
MOV COUNTER,#10
LOOP: (begin loop)
    •
    •
    •
    (end loop)
DJNZ COUNTER, LOOP
    (continue)
```

The CJNE instruction (Compare and Jump if Not Equal) can also be used for loop control as in Table 9. Two bytes are specified in the operand field of the instruction. The jump is executed only if the two bytes are not equal. In the example of Table 9 Shifting a BCD Number One Digits to the Right, the two bytes were data in R1 and the constant 2Ah. The initial data in R1 was 2Eh.

Every time the loop was executed, R1 was decremented, and the looping was to continue until the R1 data reached 2Ah.

Another application of this instruction is in “greater than, less than” comparisons. The two bytes in the operand field are taken as unsigned integers. If the first is less than the second, then the Carry Bit is set (1). If the first is greater than or equal to the second, then the Carry Bit is cleared

Machine Cycles

A machine cycle consists of a sequence of six states, numbered S1 through S6. Each state time lasts for two oscillator periods. Thus, a machine cycle takes 12 oscillator periods or 1μs if the oscillator frequency is 12MHz. Refer to Figure 14, page 30.

Each state is divided into a Phase 1 half and a Phase 2 half. State Sequence in μPSD325X devices shows that retrieve/execute sequences in states and phases for various kinds of instructions.

Normally two program retrievals are generated during each machine cycle, even if the instruction being executed does *not* require it. If the instruction being executed does not need more code bytes, the CPU simply ignores the extra retrieval, and the Program Counter is not incremented.

Execution of a one-cycle instruction (Figure 14, page 30) begins during State 1 of the machine cycle, when the opcode is latched into the Instruction Register. A second retrieve occurs during S4 of the same machine cycle. Execution is complete at the end of State 6 of this machine cycle.

The MOVX instructions take two machine cycles to execute. No program retrieval is generated during the second cycle of a MOVX instruction. This is the only time program retrievals are skipped. The retrieve/execute sequence for MOVX instruction is shown in Figure 14, page 30 (d).

Table 14. Conditional Jump Instructions

Mnemonic	Operation	Addressing Modes			
		Dir.	Ind.	Reg.	Imm
JZ rel	Jump if A = 0	Accumulator only			
JNZ rel	Jump if A ≠ 0	Accumulator only			
DJNZ <byte>,rel	Decrement and jump if not zero	X		X	
CJNE A,<byte>,rel	Jump if A ≠ <byte>	X			X
CJNE <byte>,#data,rel	Jump if <byte> ≠ #data		X	X	

Figure 14. State Sequence in μPSD325X Devices

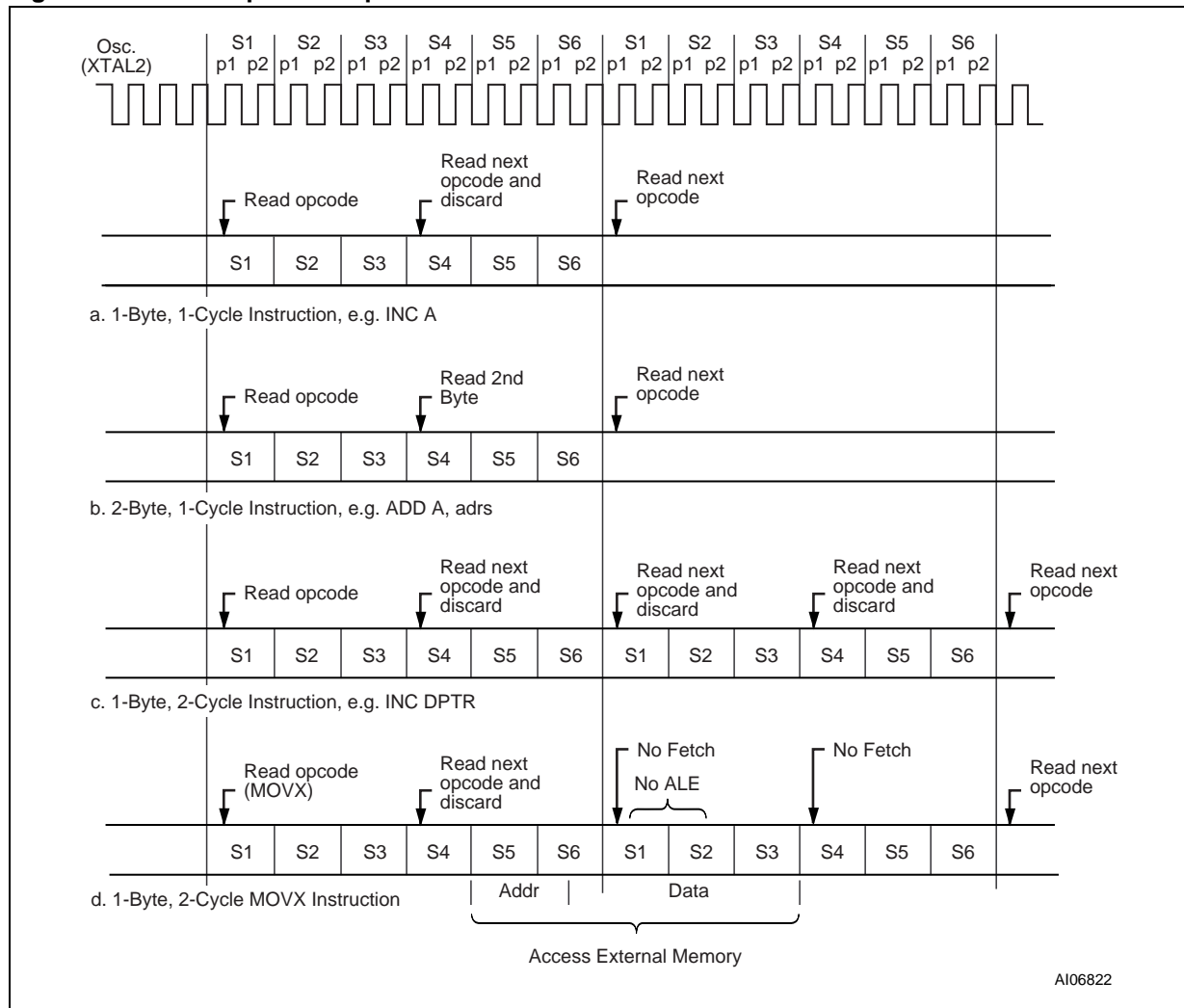

μPSD325X HARDWARE DESCRIPTION

The μPSD325X devices have a modular architecture with two main functional modules: the MCU Module and the PSD Module. The MCU Module consists of a standard 8032 core, peripherals and other system supporting functions. The PSD Module provides configurable Program and Data memories to the 8032 CPU core. In addition, it has its own set of I/O ports and a PLD with 16 macrocells for general logic implementation. Ports A,B,C, and D are general purpose programmable I/O ports

that have a port architecture which is different from Ports 0-4 in the MCU Module.

The PSD Module communicates with the CPU Core through the internal address, data bus (A0-A15, D0-D7) and control signals (RD_, WR_, PSEN_, ALE, RESET_). The user defines the Decoding PLD in the PSDsoft Development Tool and can map the resources in the PSD Module to any program or data address space.

Figure 15. μPSD325X devices Functional Modules

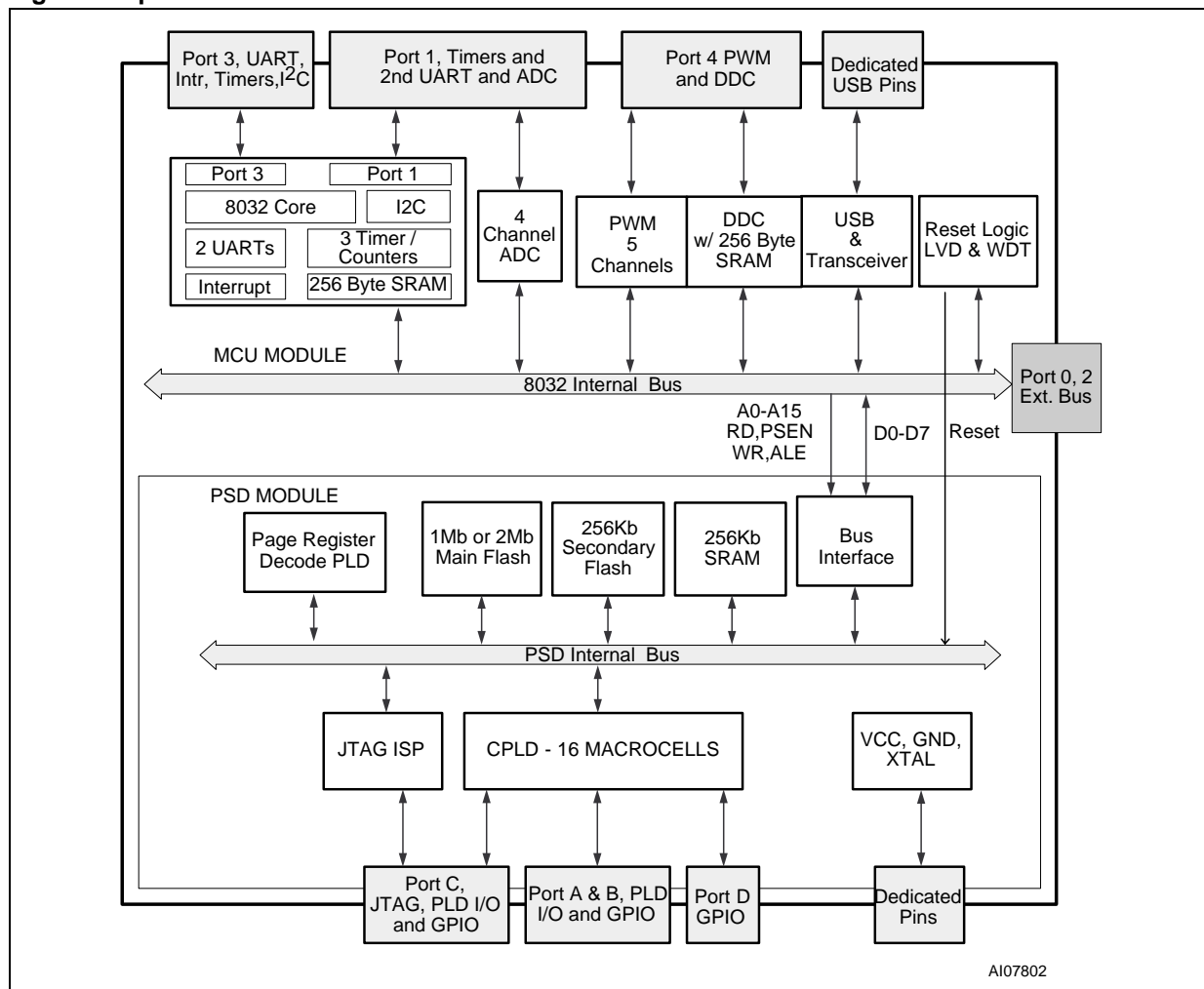

μPSD325X DEVICES

MCU MODULE DISCRIPTION

This section provides a detail description of the MCU Module system functions and Peripherals, including:

- Special Function Registers
- Timers/Counter
- Interrupts
- PWM
- Supervisory Function (LVD and Watchdog)
- USART
- Power Saving Modes
- I²C Bus
- On-chip Oscillator

- ADC
- I/O Ports
- USB

Special Function Registers

A map of the on-chip memory area called the Special Function Register (SFR) space is shown in Table 15.

Note: In the SFRs not all of the addresses are occupied. Unoccupied addresses are not implemented on the chip. READ accesses to these addresses will in general return random data, and WRITE accesses will have no effect. User software should write '0s' to these unimplemented locations.

Table 15. SFR Memory Map

F8									FF
F0	B ¹								F7
E8	UISTA ¹	UIEN	UCON0	UCON1	UCON2	USTA	UADR	UDR0	EF
E0	ACC ¹	USCL					UDT1	UDT0	E7
D8	S1CON ¹	S1STA	S1DAT	S1ADR	S2CON	S2STA	S2DAT	S2ADR	DF
D0	PSW ¹	S1SETUP	S2SETUP		RAMBUF	DDCDAT	DDCADR	DDCCON	D7
C8	T2CON ¹	T2MOD	RCAP2L	RCAP2H	TL2	TH2			CF
C0	P4 ¹								C7
B8	IP ¹								BF
B0	P3 ¹	PSCL0L	PSCL0H	PSCL1L	PSCL1H			IPA	B7
A8	IE ¹		PWM4P	PWM4W			WDKEY		AF
A0	P2 ¹	PWMCON	PWM0	PWM1	PWM2	PWM3	WDRST	IEA	A7
98	SCON	SBUF	SCON2	SBUF2					9F
90	P1 ¹	P1SFS		P3SFS	P4SFS	ASCL	ADAT	ACON	97
88	TCON ¹	TMOD	TL0	TL1	TH0	TH1			8F
80	P0 ¹	SP	DPL	DPH				PCON	87

Note: 1. Register can be bit addressing

Table 16. List of all SFR

SFR Addr	Reg Name	Bit Register Name								Reset Value	Comments
		7	6	5	4	3	2	1	0		
80	P0									FF	Port 0
81	SP									07	Stack Ptr
82	DPL									00	Data Ptr Low
83	DPH									00	Data Ptr High
87	PCON	SMOD	SMOD1	LVREN	ADSFINT	RCLK1	TCLK1	PD	IDLE	00	Power Ctrl
88	TCON	TF1	TR1	TF0	TR0	IE1	IT1	IE0	IT0	00	Timer / Cntr Control
89	TMOD	Gate	C/T	M1	M0	Gate	C/T	M1	M0	00	Timer / Cntr Mode Control
8A	TL0									00	Timer 0 Low
8B	TL1									00	Timer 1 Low
8C	TH0									00	Timer 0 High
8D	TH1									00	Timer 1 High
90	P1									FF	Port 1
91	P1SFS	P1S7	P1S6	P1S5	P1S4					00	Port 1 Select Register
93	P3SFS	P3S7	P3S6							00	Port 3 Select Register
94	P4SFS	P4S7	P4S6	P4S5	P4S4	P4S3	P4S2	P4S1	P4S0	00	Port 4 Select Register
95	ASCL									00	8-bit Prescaler for ADC clock
96	ADAT	ADAT7	ADAT6	ADAT5	ADAT4	ADAT3	ADAT2	ADAT1	ADAT0	00	ADC Data Register
97	ACON			ADEN		ADS1	ADS0	ADST	ADSF	00	ADC Control Register
98	SCON	SM0	SM1	SM2	REN	TB8	RB8	TI	RI	00	Serial Control Register
99	SBUF									00	Serial Buffer
9A	SCON2	SM0	SM1	SM2	REN	TB8	RB8	TI	RI	00	2nd UART Ctrl Register
9B	SBUF2									00	2nd UART Serial Buffer
A0	P2									FF	Port 2
A1	PWMCON	PWML	PWMP	PWME	CFG4	CFG3	CFG2	CFG1	CFG0	00	PWM Control Polarity

μPSD325X DEVICES

SFR Addr	Reg Name	Bit Register Name								Reset Value	Comments
		7	6	5	4	3	2	1	0		
A2	PWM0									00	PWM0 Output Duty Cycle
A3	PWM1									00	PWM1 Output Duty Cycle
A4	PWM2									00	PWM2 Output Duty Cycle
A5	PWM3									00	PWM3 Output Duty Cycle
A6	WDRST									00	Watch Dog Reset
A7	IEA	EDDC			ES2			EI ² C	EUSB	00	Interrupt Enable (2nd)
A8	IE	EA	-	ET2	ES	ET1	EX1	ET0	EX0	00	Interrupt Enable
A9											
AA	PWM4P									00	PWM 4 Period
AB	PWM4W									00	PWM 4 Pulse Width
AE	WDKEY									00	Watch Dog Key Register
B0	P3									FF	Port 3
B1	PSCL0L									00	Prescaler 0 Low (8-bit)
B2	PSCL0H									00	Prescaler 0 High (8-bit)
B3	PSCL1L									00	Prescaler 1 Low (8-bit)
B4	PSCL1H									00	Prescaler 1 High (8-bit)
B7	IPA	PDDC			PS2			PI2C	PUSB	00	Interrupt Priority (2nd)
B8	IP			PT2	PS	PT1	PX1	PT0	PX0	00	Interrupt Priority
C0	P4									FF	New Port 4
C8	T2CON	TF2	EXF2	RCLK	TCLK	EXEN2	TR2	C/T2	CP/RL2	00	Timer 2 Control
C9	T2MOD								DCEN	00	Timer 2 Mode

SFR Addr	Reg Name	Bit Register Name								Reset Value	Comments
		7	6	5	4	3	2	1	0		
CA	RCAP2L									00	Timer 2 Reload low
CB	RCAP2H									00	Timer 2 Reload High
CC	TL2									00	Timer 2 Low byte
CD	TH2									00	Timer 2 High byte
D0	PSW	CY	AC	FO	RS1	RS0	OV		P	00	Program Status Word
D1	S1SETUP									00	DDC I ² C (S1) Setup
D2	S2SETUP									00	I ² C (S2) Setup
D4	RAMBUF									XX	DDC Ram Buffer
D5	DDCDAT									00	DDC Data xmit register
D6	DDCADR									00	Addr pointer register
D7	DDCCON	—	EX_DAT	SWENB	DDC_AX	DDCINT	DDC1EN	SWHINT	M0	00	DDC Control Register
D8	S1CON	CR2	EN1	STA	STO	ADDR	AA	CR1	CR0	00	DDC I ² C Control Reg
D9	S1STA	GC	Stop	Intr	TX-Md	Bbusy	Blost	ACK_R	SLV	00	DDC I ² C Status
DA	S1DAT									00	Data Hold Register
DB	S1ADR									00	DDC I ² C address
DC	S2CON	CR2	EN1	STA	STO	ADDR	AA	CR1	CR0	00	I ² C Bus Control Reg
DD	S2STA	GC	Stop	Intr	TX-Md	Bbusy	Blost	ACK_R	SLV	00	I ² C Bus Status
DE	S2DAT									00	Data Hold Register
DF	S2ADR									00	I ² C address
E0	ACC									00	Accumulator
E1	USCL									00	8-bit Prescaler for USB logic
E6	UDT1	UDT1.7	UDT1.6	UDT1.5	UDT1.4	UDT1.3	UDT1.2	UDT1.1	UDT1.0	00	USB Endpt1 Data Xmit

μPSD325X DEVICES

SFR Addr	Reg Name	Bit Register Name								Reset Value	Comments
		7	6	5	4	3	2	1	0		
E7	UDT0	UDT0.7	UDT0.6	UDT0.5	UDT0.4	UDT0.3	UDT0.2	UDT0.1	UDT0.0	00	USB Endpt0 Data Xmit
E8	UISTA	SUSPND	—	RSTF	TXD0F	RXD0F	RXD1F	EOPF	RESUMF	00	USB Interrupt Status
E9	UIEN	SUSPNDI E	RSTE	RSTFIE	TXD0IE	RXD0IE	TXD1IE	EOPIE	RESUMI E	00	USB Interrupt Enable
EA	UCON0	TSEQ0	STALL0	TX0E	RX0E	TP0SiZ3	TP0SiZ2	TP0SiZ1	TP0SiZ0	00	USB Endpt0 Xmit Control
EB	UCON1	TSEQ1	EP12SEL	—	FRESUM	TP1SiZ3	TP1SiZ2	TP1SiZ1	TP1SiZ0	00	USB Endpt1 Xmit Control
EC	UCON2	—	—	—	SOUT	EP2E	EP1E	STALL2	STALL1	00	USB Control Register
ED	USTA	RSEQ	SETUP	IN	OUT	RP0SiZ3	RP0SiZ2	RP0SiZ1	RP0SiZ0	00	USB Endpt0 Status
EE	UADR	USBEN	UADD6	UADD5	UADD4	UADD3	UADD2	UADD1	UADD0	00	USB Address Register
EF	UDR0	UDR0.7	UDR0.6	UDR0.5	UDR0.4	UDR0.3	UDR0.2	UDR0.1	UDR0.0	00	USB Endpt0 Data Recv
F0	B									00	B Register

Table 17. PSD Module Register Address Offset

CSIOP Addr Offset	Register Name	Bit Register Name								Reset Value	Comments
		7	6	5	4	3	2	1	0		
00	Data In (Port A)	Reads Port pins as input									
02	Control (Port A)	Configure pin between I/O or Address Out Mode. Bit = 0 selects I/O								00	
04	Data Out (Port A)	Latched data for output to Port pins, I/O Output Mode								00	
06	Direction (Port A)	Configures Port pin as input or output. Bit = 0 selects input								00	
08	Drive (Port A)	Configures Port pin between CMOS, Open Drain or Slew rate. Bit = 0 selects CMOS								00	
0A	Input Macrocell (Port A)	Reads latched value on Input Macrocells									
0C	Enable Out (Port A)	Reads the status of the output enable control to the Port pin driver. Bit = 0 indicates pin is in input mode.									
01	Data In (Port B)										
03	Control (Port B)									00	
05	Data Out (Port B)									00	
07	Direction (Port B)									00	
09	Drive (Port B)									00	
0B	Input Macrocell (Port B)										
0D	Enable Out (Port B)										
10	Data In (Port C)										
12	Data Out (Port C)									00	
14	Direction (Port C)									00	
16	Drive (Port C)									00	
18	Input Macrocell (Port C)										
1A	Enable Out (Port C)										
11	Data In (Port D)	*	*	*	*	*		*			Only Bit 1 and 2 are used
13	Data Out (Port D)	*	*	*	*	*		*		00	Only Bit 1 and 2 are used
15	Direction (Port D)	*	*	*	*	*		*		00	Only Bit 1 and 2 are used
17	Drive (Port D)	*	*	*	*	*		*		00	Only Bit 1 and 2 are used
1B	Enable Out (Port D)	*	*	*	*	*		*			Only Bit 1 and 2 are used
20	Output Macrocells AB										

μPSD325X DEVICES

CSIOP Addr Offset	Register Name	Bit Register Name								Reset Value	Comments	
		7	6	5	4	3	2	1	0			
21	Output Macrocells BC											
22	Mask Macrocells AB											
23	Mask Macrocells BC											
C0	Primary Flash Protection	Sec7_ Prot	Sec6_ Prot	Sec5_ Prot	Sec4_ Prot	Sec3_ Prot	Sec2_ Prot	Sec1_ Prot	Sec0_ Prot			Bit = 1 sector is protected
C2	Secondary Flash Protection	Security _Bit	*	*	*	Sec3_ Prot	Sec2_ Prot	Sec1_ Prot	Sec0_ Prot			Security Bit = 1 device is secured
B0	PMMR0	*	*	PLD Mcells clk	PLD array- clk	PLD Turbo	*	APD enable	*	00		Control PLD power consumption
B4	PMMR2	*	PLD array WRh	PLD arrayAl e	PLD array Cntl2	PLD array Cntl1	PLD array Cntl0	*	*	00		Blocking inputs to PLD array
E0	Page									00		Page Register
E2	VM	Periph- mode	*	*	FL_da ta	Boot_ data	FL_co de	Boot_c ode	SR_co de			Configure 8032 Program and Data Space

Note: (Register address = csiop address + address offset; where csiop address is defined by user in PSDsoft)

* indicates bit is not used and need to set to '0.'

INTERRUPT SYSTEM

There are interrupt requests from 10 sources as follows.

- INT0 external interrupt
- 2nd USART interrupt
- Timer0 interrupt
- I²C interrupt
- INT1 external interrupt (or ADC interrupt)
- DDC interrupt
- Timer1 interrupt
- USB interrupt
- USART interrupt
- Timer2 interrupt

External Int0

- The INT0 can be either level-active or transition-active depending on Bit IT0 in register TCON. The flag that actually generates this interrupt is Bit IE0 in TCON.
- When an external interrupt is generated, the corresponding request flag is cleared by the hardware when the service routine is vectored to only if the interrupt was transition activated.
- If the interrupt was level activated then the interrupt request flag remains set until the requested interrupt is actually generated. Then it has to deactivate the request before the interrupt service routine is completed, or else another interrupt will be generated.

Timer 0 and 1 Interrupts

- Timer0 and Timer1 interrupts are generated by TF0 and TF1 which are set by an overflow of their respective Timer/Counter registers (except for Timer0 in Mode 3).
- These flags are cleared by the internal hardware when the interrupt is serviced.

Timer 2 Interrupt

- Timer2 interrupt is generated by TF2 which is set by an overflow of Timer2. This flag has to be cleared by the software - not by hardware.
- It is also generated by the T2EX signal (timer 2 external interrupt P1.1) which is controlled by EXEN2 and EXF2 Bits in the T2CON register. This is the definition of Timer 2 as per 90C320 definition.

I²C Interrupt

- The interrupt of the I²C is generated by Bit INTR in the register S2STA.
- This flag is cleared by hardware.

External Int1

- The INT1 can be either level active or transition active depending on Bit IT1 in register TCON. The flag that actually generates this interrupt is Bit IE1 in TCON.
- When an external interrupt is generated, the corresponding request flag is cleared by the hardware when the service routine is vectored to only if the interrupt was transition activated.
- If the interrupt was level activated then the interrupt request flag remains set until the requested interrupt is actually generated. Then it has to deactivate the request before the interrupt service routine is completed, or else another interrupt will be generated.
- The ADC can take over the External INT1 to generate an interrupt on conversion being completed

DDC Interrupt

- The DDC interrupt is generated either by Bit INTR in the S1STA register for DC2B protocol or by Bit DDC interrupt in the DDCCON register for DDC1 protocol or by Bit SWHINT Bit in the DDCCON register when DDC protocol is changed from DDC1 to DDC2.
- Flags except the INTR have to be cleared by the software. INTR flag is cleared by hardware.

USB Interrupt

- The USB interrupt is generated when endpoint0 has transmitted a packet or received a packet, when endpoint1 or endpoint2 has transmitted a packet, when the suspend or resume state is detected and every EOP received.
- When the USB interrupt is generated, the corresponding request flag must be cleared by software. The interrupt service routine will have to check the various USB registers to determine the source and clear the corresponding flag.
- Please see the dedicated interrupt control registers for the USB peripheral for more information.

USART Interrupt

- The USART interrupt is generated by RI (receive interrupt) OR TI (transmit interrupt).
- When the USART interrupt is generated, the corresponding request flag must be cleared by software. The interrupt service routine will have to check the various USART registers to determine the source and clear the corresponding flag.
- Both USART's are identical, except for the additional interrupt controls in the Bit 4 of the additional interrupt control registers (A7H, B7H)

Figure 16. Interrupt System

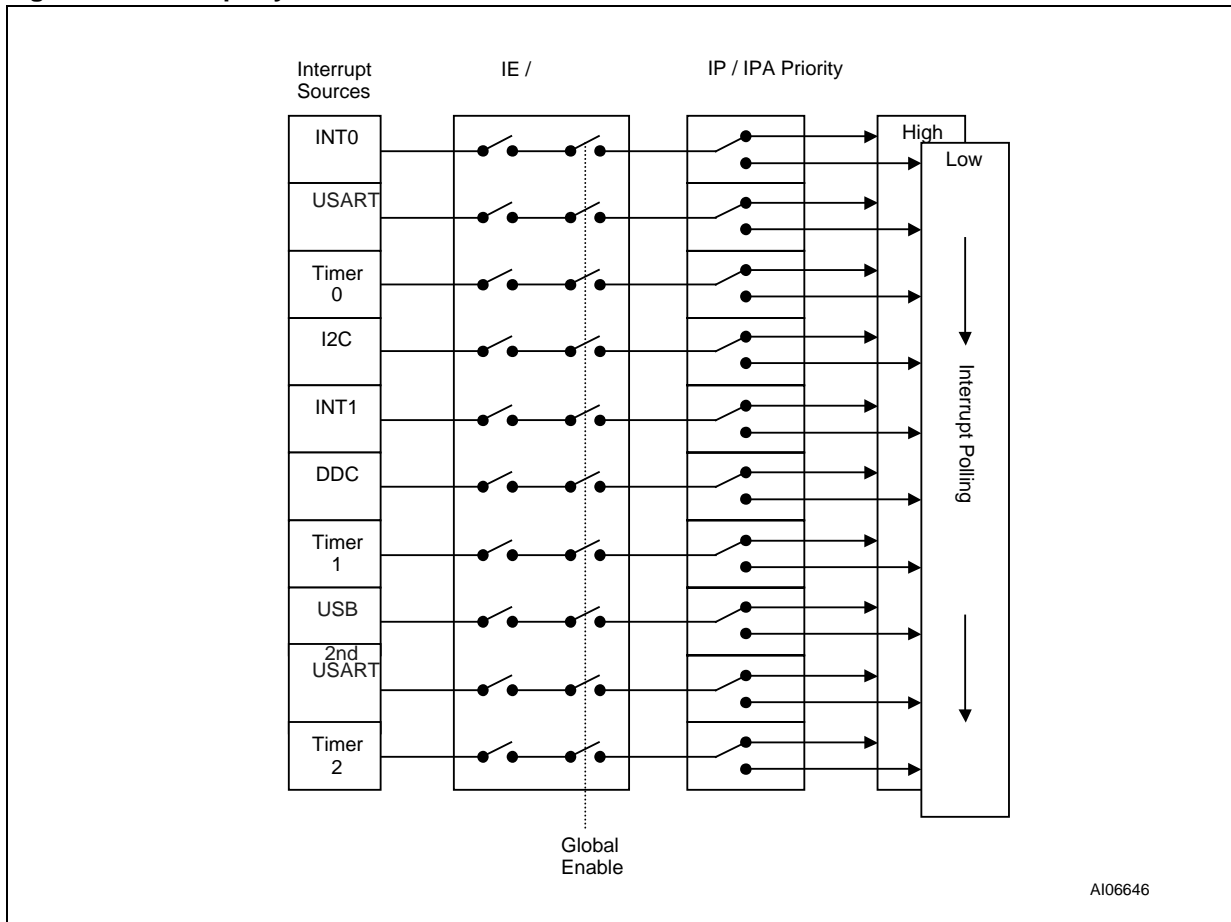

AI06646

Table 18. SFR Register

SFR Addr	Reg Name	Bit Register Name								Reset Value	Comments
		7	6	5	4	3	2	1	0		
A7	IEA	EDDC	—	—	ES2	—	—	EI ² C	EUSB	00	Interrupt Enable (2nd)
A8	IE	EA	—	ET2	ES	ET1	EX1	ET0	EX0	00	Interrupt Enable
B7	IPA	PDDC	—	—	PS2	—	—	PI ² C	PUSB	00	Interrupt Priority (2nd)
B8	IP	—	—	PT2	PS	PT1	PX1	PT0	PX0	00	Interrupt Priority

Interrupt Priority Structure

Each interrupt source can be assigned one of two priority levels. Interrupt priority levels are defined by the interrupt priority special function register IP and IPA.

0 = low priority

1 = high priority

A low priority interrupt may be interrupted by a high priority interrupt level interrupt. A high priority interrupt routine cannot be interrupted by any other interrupt source. If two interrupts of different priority occur simultaneously, the high priority level request is serviced. If requests of the same priority are received simultaneously, an internal polling sequence determines which request is serviced. Thus, within each priority level, there is a second priority structure determined by the polling sequence.

Interrupts Enable Structure

Each interrupt source can be individually enabled or disabled by setting or clearing a bit in the interrupt enable special function register IE and IEA. All

interrupt source can also be globally disabled by clearing Bit EA in IE.

Table 19. Priority Levels

Source	Priority with Level
Int0	0 (highest)
2nd USART	1
Timer0	2
I ² C	3
Int1	4
DDC	5
Timer1	6
USB	7
1st USART	8
Timer2+EXF2	9 (lowest)

Table 20. Description of the IE Bits

Bit	Symbol	Function
7	EA	Disable all interrupts: 0: no interrupt with be acknowledged 1: each interrupt source is individually enabled or disabled by setting or clearing its enable bit
6	—	Reserved
5	ET2	Enable Timer2 interrupt
4	ES	Enable USART interrupt
3	ET1	Enable Timer1 interrupt
2	EX1	Enable external interrupt (Int1)
1	ET0	Enable Timer0 interrupt
0	EX0	Enable external interrupt (Int0)

Table 21. Description of the IEA Bits

Bit	Symbol	Function
7	EDDC	Enable DDC interrupt
6	—	Not used
5	—	Not used
4	ES2	Enable 2nd USART interrupt
3	—	Not used
2	—	Not used
1	EI2C	Enable I ² C interrupt
0	EUSB	Enable USB interrupt

Table 22. Description of the IP Bits

Bit	Symbol	Function
7	—	Reserved
6	—	Reserved
5	PT2	Timer2 interrupt priority level
4	PS	USART interrupt priority level
3	PT1	Timer1 interrupt priority level
2	PX1	External interrupt (Int1) priority level
1	PT0	Timer0 interrupt priority level
0	PX0	External interrupt (Int0) priority level

Table 23. Description of the IPA Bits

Bit	Symbol	Function
7	PDDC	DDC interrupt priority level
6	—	Not used
5	—	Not used
4	PS2	2nd USART interrupt priority level
3	—	Not used
2	—	Not used
1	PI2C	I ² C interrupt priority level
0	PUSB	USB interrupt priority level

How Interrupts are Handled

The interrupt flags are sampled at S5P2 of every machine cycle. The samples are polled during following machine cycle. If one of the flags was in a set condition at S5P2 of the preceding cycle, the polling cycle will find it and the interrupt system will generate an LCALL to the appropriate service routine, provided this H/W generated LCALL is not blocked by any of the following conditions:

- An interrupt of equal priority or higher priority level is already in progress.
- The current machine cycle is not the final cycle in the execution of the instruction in progress.
- The instruction in progress is RETI or any access to the interrupt priority or interrupt enable registers.

The polling cycle is repeated with each machine cycle, and the values polled are the values that were present at S5P2 of the previous machine cycle.

Note: If an interrupt flag is active but being responded to for one of the above mentioned conditions, if the flag is still inactive when the blocking condition is removed, the denied interrupt will not be serviced. In other words, the fact that the interrupt flag was once active but not serviced is not remembered. Every polling cycle is new.

The processor acknowledges an interrupt request by executing a hardware generated LCALL to the appropriate service routine. The hardware generated LCALL pushes the contents of the Program Counter on to the stack (but it does not save the PSW) and reloads the PC with an address that de-

pends on the source of the interrupt being vectored to as shown in Table 24.

Execution proceeds from that location until the RETI instruction is encountered. The RETI instruction informs the processor that the interrupt routine is no longer in progress, then pops the top two bytes from the stack and reloads the Program Counter. Execution of the interrupted program continues from where it left off.

Note: A simple RET instruction would also return execution to the interrupted program, but it would have left the interrupt control system thinking an interrupt was still in progress, making future interrupts impossible.

Table 24. Vector Addresses

Source	Vector Address
Int0	0003h
2nd USART	004Bh
Timer0	000Bh
I ² C	0043h
Int1	0013h
DDC	003Bh
Timer1	001Bh
USB	0033h
1st USART	0023h
Timer2+EXF2	002Bh

POWER-SAVING MODE

Two software selectable modes of reduced power consumption are implemented.

Idle Mode

The following Functions are Switched Off.

- CPU (Halted)

The following Function Remain Active During Idle Mode.

- External Interrupts
- Timer0, Timer1, Timer2
- DDC Interface
- PWM Units
- USB Interface

- USART
- 8-bit ADC
- I²C Interface

Note: Interrupt or $\overline{\text{RESET}}$ terminates the Idle Mode.

Power-Down Mode

- System Clock Halted
- LVD Logic Remains Active
- SRAM contents remains unchanged
- The SFRs retain their value until a $\overline{\text{RESET}}$ is asserted

Note: The only way to exit Power-down Mode is a $\overline{\text{RESET}}$.

Table 25. Power-Saving Mode Power Consumption

Mode	Addr/Data	Ports1,3,4	PWM	I ² C	DDC	USB
Idle	Maintain Data	Maintain Data	Active	Active	Active	Active
Power-down	Maintain Data	Maintain Data	Disable	Disable	Disable	Disable

Power Control Register

The Idle and Power-down Modes are activated by software via the PCON register.

Table 26. Pin Status During Idle and Power-down Mode

SFR Addr	Reg Name	Bit Register Name								Reset Value	Comments
		7	6	5	4	3	2	1	0		
87	PCON	SMOD	SMOD1	LVREN	ADSFINT	RCLK1	TCLK1	PD	IDLE	00	Power Ctrl

Table 27. Description of the PCON Bits

Bit	Symbol	Function
7	SMOD	Double baud data rate bit UART
6	SMOD1	Double baud data rate bit 2nd UART
5	LVREN	LVR disable bit (active High)
4	ADSFINT	Enable ADC interrupt
3	RCLK1 ¹	Received clock flag (UART 2)
2	TCLK1 ¹	Transmit clock flag (UART 2)
1	PD	Activate Power-down Mode (High enable)
0	IDL	Activate Idle Mode (High enable)

Note: 1. See the T2CON register for details of the flag description



Idle Mode

The instruction that sets PCON.0 is the last instruction executed in the normal operating mode before Idle Mode is activated. Once in the Idle Mode, the CPU status is preserved in its entirety: Stack pointer, Program counter, Program status word, Accumulator, RAM and All other registers maintain their data during Idle Mode.

There are three ways to terminate the Idle Mode.

- Activation of any enabled interrupt will cause PCON.0 to be cleared by hardware terminating Idle mode. The interrupt is serviced, and following return from interrupt instruction RETI, the next instruction to be executed will be the one which follows the instruction that wrote a logic '1' to PCON.0.

- External hardware reset: the hardware reset is required to be active for two machine cycle to complete the RESET operation.
- Internal reset: the microcontroller restarts after 3 machine cycles in all cases.

Power-Down Mode

The instruction that sets PCON.1 is the last executed prior to going into the Power-down Mode. Once in Power-down Mode, the oscillator is stopped. The contents of the on-chip RAM and the Special Function Register are preserved.

The Power-down Mode can be terminated by an external RESET.

I/O PORTS (MCU MODULE)

The MCU Module has five ports: Port0, Port1, Port2, Port3 and Port 4. (Refer to the PSD Module section on I/O ports A,B,C and D). Ports P0 and P2 are dedicated for the external address and data bus and is not available in the 80 pin package devices.

Port1 - Port3 are the same as in the standard 8032 micro-controllers, with the exception of the additional special peripheral functions. All ports are bi-directional. Pins of which the alternative function is not used may be used as normal bi-directional I/O.

The use of Port1- Port4 pins as alternative functions are carried out automatically by the μPSD325X devices provided the associated SFR Bit is set HIGH.

The following SFR registers (Tables 29, 30, and 31) are used to control the mapping of alternate

functions onto the I/O port bits. Port 1 alternate functions are controlled using the P1SFS register, except for Timer 2 and the 2nd UART which are enabled by their configuration registers. P1.0 to P1.3 are default to GPIO after reset.

Port 3 pins 6 and 7 have been modified from the standard 8032. These pins that were used for READ and WRITE control signals are now GPIO or I²C bus pins. The READ and WRITE pins are assigned to dedicated pins.

Port 3 and Port 4 alternate functions are controlled using the P3SFS and P4SFS Special Function Selection registers. After a reset, the I/O pins default to GPIO. The alternate function is enabled if the corresponding bit in the PXSFS register is set to '1.'

Table 28. I/O Port Functions

Port Name	Main Function	Alternate
Port 1	GPIO	Timer 2 - Bits 0,1 2nd UART - Bits 2,3 ADC - Bits 4..7
Port 3	GPIO	UART - Bits 0,1 Interrupt - Bits 2,3 Timers - Bits 4,5 I ² C - Bits 6,7
Port 4	GPIO	DDC - Bits 0..2 PWM - Bits 3..7
USB +/-	USB +/- Only	

Table 29. P1SFS (91H)

7	6	5	4	3	2	1	0
0=Port 1.7 1=ACH3	0=Port 1.6 1=ACH2	0=Port 1.5 1=ACH1	0=Port 1.4 1=ACH0	Bits Reserved		Bits Reserved	

Table 30. P3SFS (93H)

7	6	5	4	3	2	1	0
0 = Port 1.7 1 = SCL from I ² C unit	0 = Port 1.6 1 = SDA from I ² C unit	Bits are reserved.					

Table 31. P4SFS (94H)

7	6	5	4	3	2	1	0
0=Port 4.7 1=PWM 4	0=Port 4.6 1=PWM 3	0=Port 4.5 1=PWM 2	0=Port 4.4 1=PWM 1	0=Port 4.3 1=PWM 0	0=Port 4.2 1=V _{SYNC}	0=Port 4.1 1=DDC - SCL	0=Port 4.0 1=DDC - SDA



PORT Type and Description

Figure 17. PORT Type and Description (Part 1)

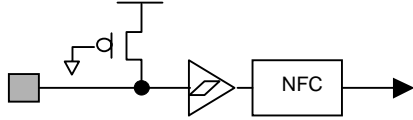
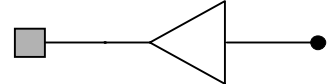
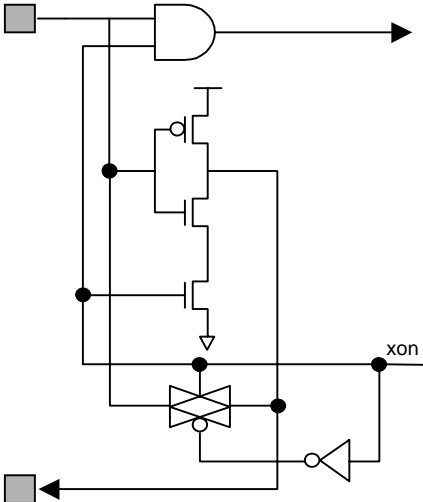
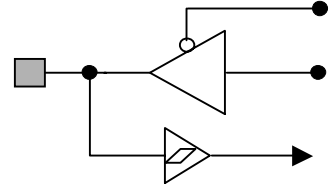
Symbol	In / Out	Circuit	Description
RESET	I		<ul style="list-style-type: none"> Schmitt input with internal pull-up CMOS compatible interface NFC : 400ns
WR, RD,ALE, PSEN	O		<p>Output only</p> <p>Sink current : 5mA</p>
XTAL1, XTAL2	I O		<p>On-chip oscillator</p> <p>On-chip feedback resistor</p> <p>Stop in the power down mode</p> <p>External clock input available</p> <p>CMOS compatible interface</p>
PORT0	I/O		<p>Bidirectional I/O port</p> <p>Schmitt input</p> <p>Open-drain output(5V)</p> <p>Address Output (Push-Pull)</p> <p>Sink current : 5mA</p> <p>CMOS compatible interface</p> <p>Source current: 5mA</p>

A106653

Figure 18. PORT Type and Description (Part 2)

Symbol	In/Out	Circuit	Function
PORT1 <3:0>, PORT3, PORT4<7:3,1:0> PORT2	I/O		Bidirectional I/O port with internal pull-ups Schmitt input Sink current : 5mA CMOS compatible interface Source current =5mA when push-pull output mode.
PORT1 <7:4 >	I/O		Bidirectional I/O port with internal pull-ups Schmitt input Sink current : 5mA CMOS compatible interface Analog input option Source current =5mA
PORT4.2	I/O		Bidirectional I/O port with internal pull-ups Schmitt input. Sink current : 5mA TTL compatible interface Pull-up when reset Address Latch Enable Program Strobe Enable Source current =5mA
USB - , USB +	I/O		Bidirectional I/O port Schmitt input TTL compatible interface

AI06654

OSCILLATOR

The oscillator circuit of the μPSD325X devices is a single stage inverting amplifier in a Pierce oscillator configuration. The circuitry between XTAL1 and XTAL2 is basically an inverter biased to the transfer point. Either a crystal or ceramic resonator can be used as the feedback element to complete

the oscillator circuit. Both are operated in parallel resonance.

XTAL1 is the high gain amplifier input, and XTAL2 is the output. To drive the μPSD325X devices externally, XTAL1 is driven from an external source and XTAL2 left open-circuit.

Figure 19. Oscillator

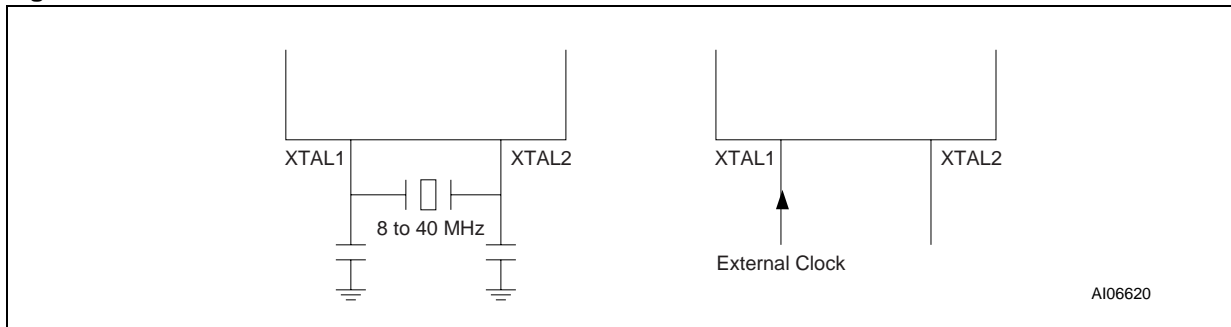

SUPERVISORY

There are four ways to invoke a reset and initialize the μPSD325X devices.

- Via the external $\overline{\text{RESET}}$ pin
- Via the internal LVR Block.

- Via USB bus reset signaling.
- Via Watch Dog timer

The $\overline{\text{RESET}}$ mechanism is illustrated in Figure 20.

Figure 20. $\overline{\text{RESET}}$ Configuration

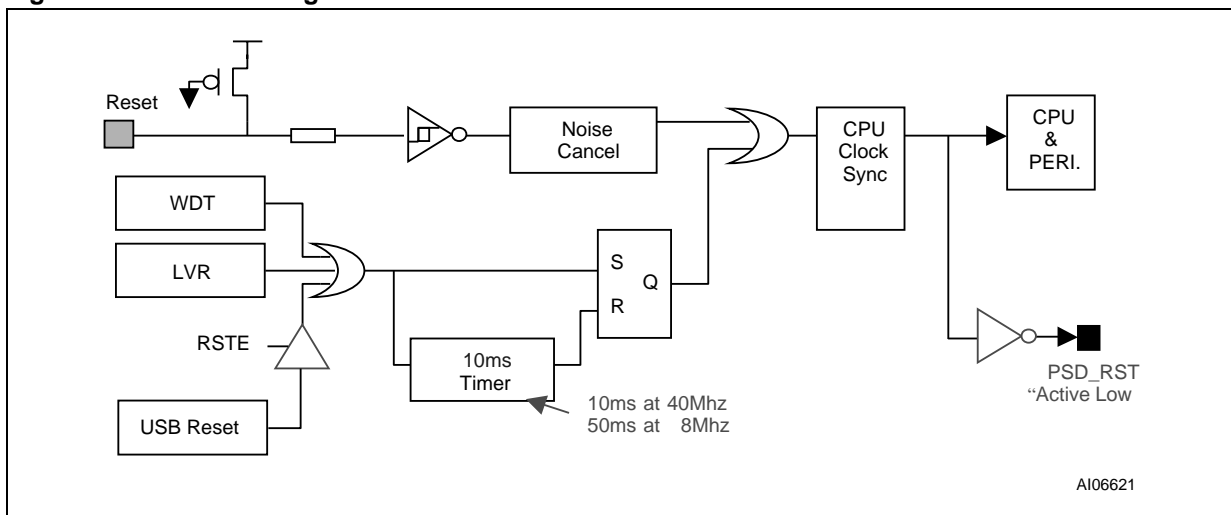

Each $\overline{\text{RESET}}$ source will cause an internal reset signal active. The CPU responds by executing an internal reset and puts the internal registers in a defined state. This internal reset is also routed as an active low reset input to the PSD Module.

External Reset

The $\overline{\text{RESET}}$ pin is connected to a Schmitt trigger for noise reduction. A $\overline{\text{RESET}}$ is accomplished by holding the $\overline{\text{RESET}}$ pin LOW for at least 1ms at power up while the oscillator is running. Refer to AC spec on other $\overline{\text{RESET}}$ timing requirements.

Low V_{DD} Voltage Reset

An internal reset is generated by the LVR circuit when the V_{DD} drops below the reset threshold. After V_{DD} reaching back up to the reset threshold, the $\overline{\text{RESET}}$ signal will remain asserted for 10ms before it is released. On initial power-up the LVR is enabled (default). After power-up the LVR can be disabled via the LVREN Bit in the PCON Register.

Note: The LVR logic is still functional in both the Idle and Power-down Modes.

The reset threshold:

- 5V operation: 4V +/- 0.25V
- 3.3V operation: 2.5V +/-0.2V

This logic supports approximately 0.1V of hysteresis and 1μs noise-cancelling delay.

Watchdog Timer Overflow

The Watchdog timer generates an internal reset when its 22-bit counter overflows. See Watchdog Timer section for details.

USB Reset

The USB reset is generated by a detection on the USB bus $\overline{\text{RESET}}$ signal. A single-end zero on its upstream port for 4 to 8 times will set RSTF Bit in UISTA register. If Bit 6 (RSTE) of the UIEN Register is set, the detection will also generate the $\overline{\text{RESET}}$ signal to reset the CPU and other peripherals in the MCU.

WATCHDOG TIMER

The hardware watchdog timer (WDT) resets the μPSD325X devices when it overflows. The WDT is intended as a recovery method in situations where the CPU may be subjected to a software upset. To prevent a system reset the timer must be reloaded in time by the application software. If the processor suffers a hardware/software malfunction, the software will fail to reload the timer. This failure will result in a reset upon overflow thus preventing the processor running out of control.

In the Idle Mode the watchdog timer and reset circuitry remain active. The WDT consists of a 22-bit counter, the Watchdog Timer RESET (WDRST) SFR and Watchdog Key Register (WDKEY).

Since the WDT is automatically enabled while the processor is running, the user only needs to be concerned with servicing it.

The 22-bit counter overflows when it reaches 4194304 (3FFFFFFH). The WDT increments once every machine cycle.

This means the user must reset the WDT at least every 4194304 machine cycles (1.258 seconds at 40MHz). To reset the WDT the user must write a value between 00-7EH to the WDRST register. The value that is written to the WDRST is loaded to the 7MSB of the 22-bit counter. This allows the user to pre-load the counter to an initial value to generate a flexible Watchdog time out period. Writing a "00" to WDRST clears the counter.

The watchdog timer is controlled by the watchdog key register, WDKEY. Only pattern 01010101 (=55H), disables the watchdog timer. The rest of pattern combinations will keep the watchdog timer enabled. This security key will prevent the watchdog timer from being terminated abnormally when the function of the watchdog timer is needed.

In Idle Mode, the oscillator continues to run. To prevent the WDT from resetting the processor while in Idle, the user should always set up a timer that will periodically exit Idle, service the WDT, and re-enter Idle Mode.

Table 32. Watchdog Timer Key Register (WDKEY: 0AEH)

7	6	5	4	3	2	1	0
WDKEY7	WDKEY6	WDKEY5	WDKEY4	WDKEY3	WDKEY2	WDKEY1	WDKEY0

Table 33. Description of the WDKEY Bits

Bit	Symbol	Function
7 to 0	WDKEY7 to WDKEY0	Enable or disable watchdog timer. 01010101 (=55h): disable watchdog timer. Others: enable watchdog timer

μPSD325X DEVICES

Watchdog reset pulse width depends on the clock frequency. The reset period is $T_{fosc} \times 12 \times 2^{22}$. The \overline{RESET} pulse width is $T_{fosc} \times 12 \times 2^{15}$.

Figure 21. \overline{RESET} Pulse Width

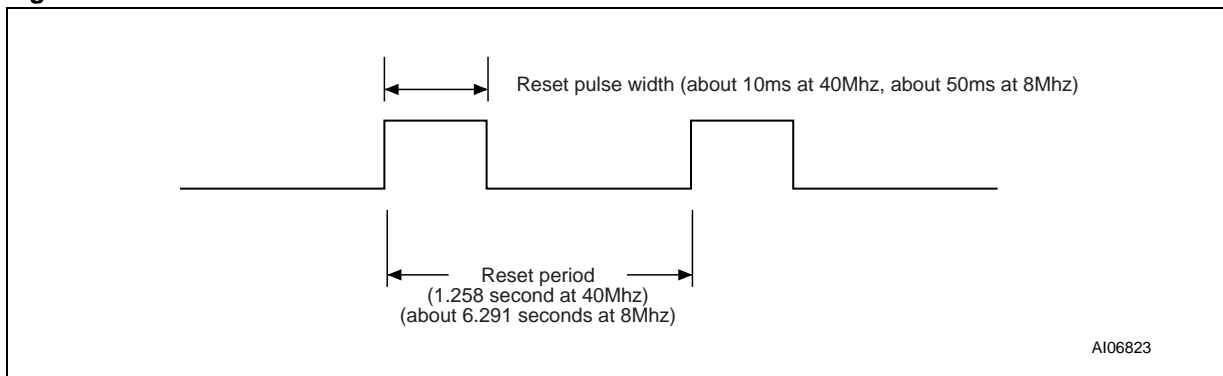

Table 34. Watchdog Timer Clear Register (WDRST: 0A6H)

7	6	5	4	3	2	1	0
Reserved	WDRST6	WDRST5	WDRST4	WDRST3	WDRST2	WDRST1	WDRST0

Table 35. Description of the WDRST Bits

Bit	Symbol	Function
7	—	Reserved
6 to 0	WDRST6 to WDRST0	To reset watchdog timer, write any value between 00h and 7Eh to this register. This value is loaded to the 7 most significant bits of the 22-bit counter. For example: MOV WDRST,#1EH

Note: The Watchdog Timer (WDT) is enabled at power-up or reset and must be served or disabled.

TIMER/COUNTERS (TIMER0, TIMER1 AND TIMER2)

The μPSD325X devices has three 16-bit Timer/Counter registers: Timer 0, Timer 1 and Timer2. All of them can be configured to operate either as timers or event counters and are compatible with standard 8032 architecture.

In the “Timer” function, the register is incremented every machine cycle. Thus, one can think of it as counting machine cycles. Since a machine cycle consists of 6 CPU clock periods, the count rate is 1/6 of the CPU clock frequency.

In the “Counter” function, the register is incremented in response to a 1-to-0 transition at its corresponding external input pin, T0 or T1. In this function, the external input is sampled during S5P2 of every machine cycle. When the samples show a high in one cycle and a low in the next cycle, the count is incremented. The new count value appears in the register during S2P1 of the cycle following the one in which the transition was de-

tected. Since it takes 2 machine cycles (12 CPU clock periods) to recognize a 1-to-0 transition, the maximum count rate is 1/12 of the CPU clock frequency. There are no restrictions on the duty cycle of the external input signal, but to ensure that a given level is sampled at least once before it changes, it should be held for at least one full cycle. In addition to the “Timer” or “Counter” selection, Timer0 and Timer1 have four operating modes from which to select.

Timer0 and Timer1

The “Timer” or “Counter” function is selected by control bits C/ T in the Special Function Register TMOD. These Timer/Counters have four operating modes, which are selected by bit-pairs (M1, M0) in TMOD. Modes 0, 1, and 2 are the same for Timers/ Counters. Mode 3 is different. The four operating modes are de-scribed in the following text.

Table 36. Control Register (TCON)

7	6	5	4	3	2	1	0
TF1	TR1	TF0	TR0	IE1	IT1	IE0	IT0

Table 37. Description of the TCON Bits

Bit	Symbol	Function
7	TF1	Timer 1 overflow flag. Set by hardware on Timer/Counter overflow. Cleared by hardware when processor vectors to interrupt routine
6	TR1	Timer 1 run control bit. Set/cleared by software to turn Timer/Counter on or off
5	TF0	Timer 0 overflow flag. Set by hardware on Timer/Counter overflow. Cleared by hardware when processor vectors to interrupt routine
4	TR0	Timer 0 run control bit. Set/cleared by software to turn Timer/Counter on or off
3	IE1	Interrupt 1 Edge flag. Set by hardware when external interrupt edge detected. Cleared when interrupt processed
2	IT1	Interrupt 1 Type control bit. Set/cleared by software to specify falling-edge/low-level triggered external interrupt
1	IE0	Interrupt 0 Edge flag. Set by hardware when external interrupt edge detected. Cleared when interrupt processed
0	IT0	Interrupt 0 Type control bit. Set/cleared by software to specify falling-edge/low-level triggered external interrupt

Mode 0. Putting either Timer into Mode 0 makes it look like an 8048 Timer, which is an 8-bit Counter with a divide-by-32 prescaler. Figure 22 shows the Mode 0 operation as it applies to Timer1.

In this mode, the Timer register is configured as a 13-bit register. As the count rolls over from all '1s' to all '0s,' it sets the Timer interrupt flag TF1. The counted input is enabled to the Timer when TR1 = 1 and either GATE = 0 or /INT1 = 1. (Setting GATE = 1 allows the Timer to be controlled by external input /INT1, to facilitate pulse width measurements). TR1 is a control bit in the Special Function Regis-

ter TCON (TCON Control Register). GATE is in TMOD.

The 13-bit register consists of all 8 bits of TH1 and the lower 5 bits of TL1. The upper 3 bits of TL1 are indeterminate and should be ignored. Setting the run flag does not clear the registers.

Mode 0 operation is the same for the Timer0 as for Timer1. Substitute TR0, TF0, and /INT0 for the corresponding Timer1 signals in Figure 22. There are two different GATE Bits, one for Timer1 and one for Timer0.

Mode 1. Mode 1 is the same as Mode 0, except that the Timer register is being run with all 16 bits.

Table 38. TMOD Register (TMOD)

7	6	5	4	3	2	1	0
Gate	C/T	M1	M0	Gate	C/T	M1	M0

Table 39. Description of the TMOD Bits

Bit	Symbol	Timer	Function
7	Gate	Timer1	Gating control when set. Timer/Counter 1 is enabled only while INT1 pin is High and TR1 control pin is set. When cleared, Timer 1 is enabled whenever TR1 control bit is set
6	C/T		Timer or Counter selector, cleared for timer operation (input from internal system clock); set for counter operation (input from T1 input pin)
5	M1		(M1,M0)=(0,0): 13-bit Timer/Counter, TH1, with TL1 as 5-bit prescaler (M1,M0)=(0,1): 16-bit Timer/Counter. TH1 and TL1 are cascaded. There is no prescaler. (M1,M0)=(1,0): 8-bit auto-reload Timer/Counter. TH1 holds a value which is to be reloaded into TL1 each time it overflows (M1,M0)=(1,1): Timer/Counter 1 stopped
4	M0		
3	Gate	Timer0	Gating control when set. Timer/Counter 0 is enabled only while INT0 pin is High and TR0 control pin is set. When cleared, Timer 0 is enabled whenever TR0 control bit is set
2	C/T		Timer or Counter selector, cleared for timer operation (input from internal system clock); set for counter operation (input from T0 input pin)
1	M1		(M1,M0)=(0,0): 13-bit Timer/Counter, TH0, with TL0 as 5-bit prescaler (M1,M0)=(0,1): 16-bit Timer/Counter. TH0 and TL0 are cascaded. There is no prescaler. (M1,M0)=(1,0): 8-bit auto-reload Timer/Counter. TH0 holds a value which is to be reloaded into TL0 each time it overflows (M1,M0)=(1,1): TL0 is an 8-bit Timer/Counter controlled by the standard Timer 0 control bits. TH0 is an 8-bit timer only controlled by Timer 1 control bits
0	M0		

Figure 22. Timer/Counter Mode 0: 13-bit Counter

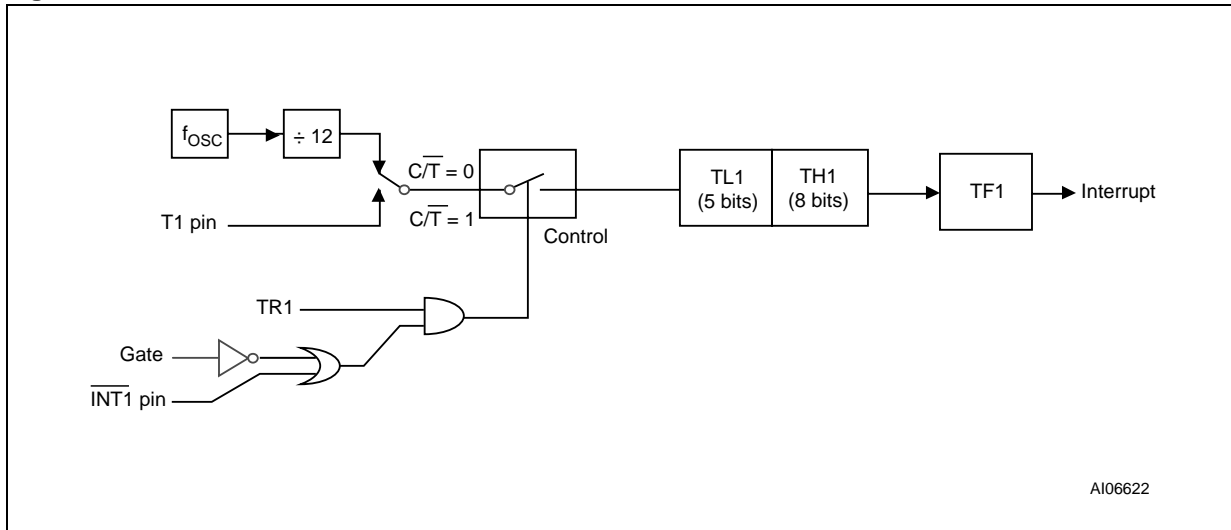

Figure 23. Timer/Counter Mode 2: 8-bit Auto-reload

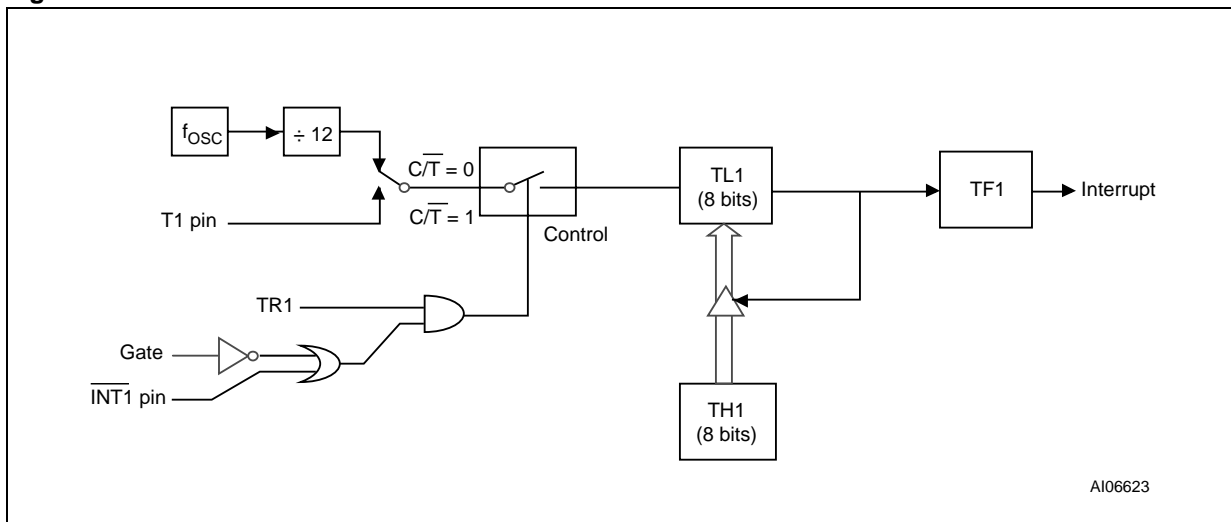
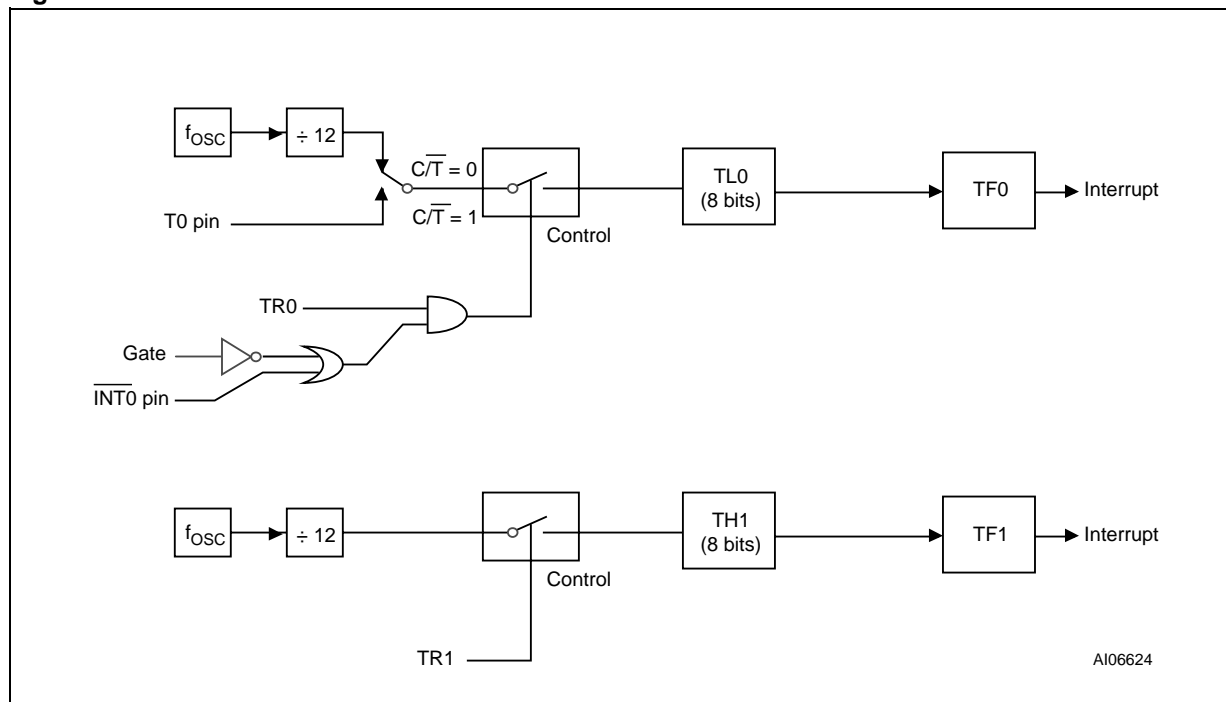

Figure 24. Timer/Counter Mode 3: Two 8-bit Counters



Mode 2. Mode 2 configures the Timer register as an 8-bit Counter (TL1) with automatic reload, as shown in Figure 23. Overflow from TL1 not only sets TF1, but also reloads TL1 with the contents of TH1, which is preset by software. The reload leaves TH1 unchanged. Mode 2 operation is the same for Timer/Counter 0.

Mode 3. Timer 1 in Mode 3 simply holds its count. The effect is the same as setting TR1 = 0.

Timer 0 in Mode 3 establishes TL0 and TH0 as two separate counters. The logic for Mode 3 on Timer 0 is shown in Figure 24. TL0 uses the Timer 0 control Bits: C/T, GATE, TR0, INT0, and TF0. TH0 is locked into a timer function (counting machine cycles) and takes over the use of TR1 and TF1 from Timer 1. Thus, TH0 now controls the “Timer 1” interrupt.

Mode 3 is provided for applications requiring an extra 8-bit timer on the counter. With Timer 0 in Mode 3, an μPSD325X devices can look like it has three Timer/Counters. When Timer 0 is in Mode 3, Timer 1 can be turned on and off by switching it out of and into its own Mode 3, or can still be used by the serial port as a baud rate generator, or in fact, in any application not requiring an interrupt.

Timer 2

Like timer 0 and 1, timer 2 can operate as either an event timer or as an event counter. This is selected by Bit C/T2 in the special function register T2CON. It has three operating modes: capture,

autoload, and baud rate generator, which are selected by bits in the T2CON as shown in Table 41. In the Capture Mode there are two options which are selected by Bit EXEN2 in T2CON. If EXEN2 = 0, then Timer 2 is a 16-bit timer or counter which upon overflowing sets Bit TF2, the Timer 2 overflow bit, which can be used to generate an interrupt. If EXEN2 = 1, then Timer 2 still does the above, but with the added feature that a 1-to-0 transition at external input T2EX causes the current value in the Timer 2 registers, TL2 and TH2, to be captured into registers RCAP2L and RCAP2H, respectively. In addition, the transition at T2EX causes Bit EXF2 in T2CON to be set, and EXF2 like TF2 can generate an interrupt. The Capture Mode is illustrated in Figure 25.

In the Auto-reload Mode, there are again two options, which are selected by bit EXEN2 in T2CON. If EXEN2 = 0, then when Timer 2 rolls over it not only sets TF2 but also causes the Timer 2 registers to be reloaded with the 16-bit value in registers RCAP2L and RCAP2H, which are preset by software. If EXEN2 = 1, then Timer 2 still does the above, but with the added feature that a 1-to-0 transition at external input T2EX will also trigger the 16-bit reload and set EXF2. The Auto-reload Mode is illustrated in Standard Serial Interface (UART) Figure 26. The Baud Rate Generation Mode is selected by (RCLK, RCLK1)=1 and/or (TCLK, TCLK1)=1. It will be described in conjunction with the serial port.



Table 40. Timer/Counter 2 Control Register (T2CON)

7	6	5	4	3	2	1	0
TF2	EXF2	RCLK	TCLK	EXEN2	TR2	C/ \bar{T} 2	CP/ \bar{R} L2

Table 41. Description of the T2CON Bits

Bit	Symbol	Function
7	TF2	Timer 2 overflow flag. Set by a Timer 2 overflow, and must be cleared by software. TF2 will not be set when either (RCLK, RCLK1)=1 or (TCLK, TCLK)=1
6	EXF2	Timer 2 external flag set when either a capture or reload is caused by a negative transition on T2EX and EXEN2=1. When Timer 2 interrupt is enabled, EXF2=1 will cause the CPU to vector to the Timer 2 interrupt routine. EXF2 must be cleared by software
5	RCLK ¹	Receive clock flag (UART 1). When set, causes the serial port to use Timer 2 overflow pulses for its receive clock in Modes 1 and 3. TCLK=0 causes Timer 1 overflow to be used for the receive clock
4	TCLK ¹	Transmit clock flag (UART 1). When set, causes the serial port to use Timer 2 overflow pulses for its transmit clock in Modes 1 and 3. TCLK=0 causes Timer 1 overflow to be used for the transmit clock
3	EXEN2	Timer 2 external enable flag. When set, allows a capture or reload to occur as a result of a negative transition on T2EX if Timer 2 is not being used to clock the serial port. EXEN2=0 causes Time 2 to ignore events at T2EX
2	TR2	Start/stop control for Timer 2. A logic 1 starts the timer
1	C/ \bar{T} 2	Timer or Counter select for Timer 2. Cleared for timer operation (input from internal system clock, t _{CPU}); set for external event counter operation (negative edge triggered)
0	CP/ \bar{R} L2	Capture/reload flag. When set, capture will occur on negative transition of T2EX if EXEN2=1. When cleared, auto-reload will occur either with Timer 2 overflows, or negative transitions of T2EX when EXEN2=1. When either (RCLK, RCLK1)=1 or (TCLK, TCLK)=1, this bit is ignored, and timer is forced to auto-reload on Timer 2 overflow

Note: 1. The RCLK1 and TCLK1 Bits in the PCON Register control UART 2, and have the same function as RCLK and TCLK.

Table 42. Timer/Counter2 Operating Modes

Mode	T2CON			T2MOD DECN	T2CON EXEN	P1.1 T2EX	Remarks	Input Clock	
	RxCLK or TxCLK	CP/ RL2	TR2					Internal	External (P1.0/T2)
16-bit Auto- reload	0	0	1	0	0	x	reload upon overflow	fosc/12	MAX fosc/24
	0	0	1	0	1	↓	reload trigger (falling edge)		
	0	0	1	1	x	0	Down counting		
	0	0	1	1	x	1	Up counting		
16-bit Capture	0	1	1	x	0	x	16-bit Timer/Counter (only up counting)	fosc/12	MAX fosc/24
	0	1	1	x	1	↓	Capture (TH1,TL2) → (RCAP2H,RCAP2L)		
Baud Rate Generator	1	x	1	x	0	x	No overflow interrupt request (TF2)	fosc/12	MAX fosc/24
	1	x	1	x	1	↓	Extra external interrupt (Timer 2)		
Off	x	x	0	x	x	x	Timer 2 stops	—	—

Note: ↓ = falling edge

Figure 25. Timer 2 in Capture Mode

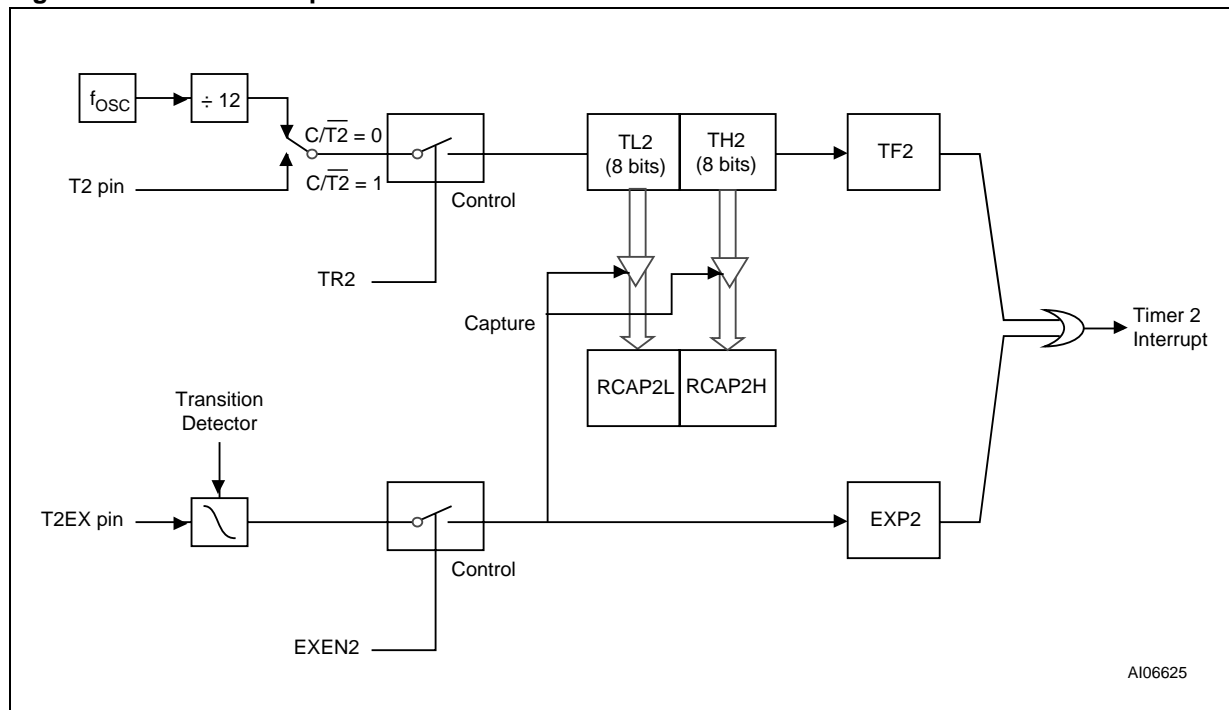
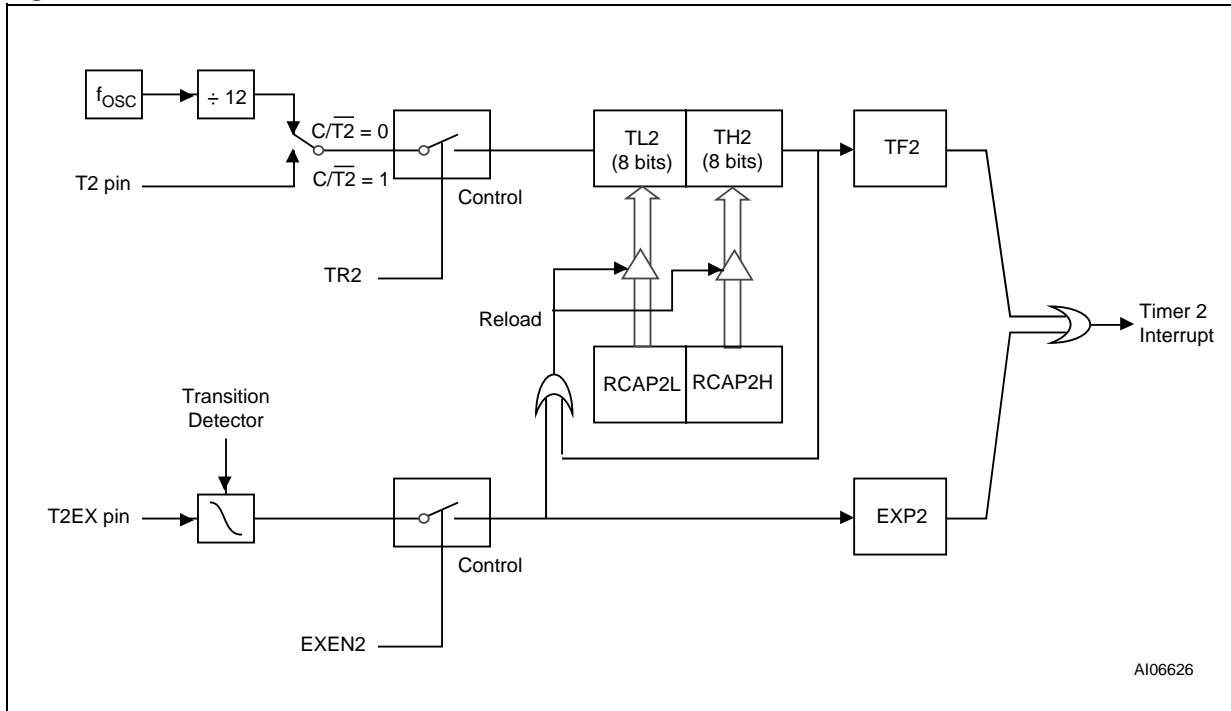

Figure 26. Timer 2 in Auto-Reload Mode



AI06626

STANDARD SERIAL INTERFACE (UART)

The µPSD325X devices provides two standard 8032 UART serial ports. The first port is connected to pin P3.0 (RX) and P3.1 (TX). The second port is connected to pin P1.2 (RX) and P1.3(TX). The operation of the two serial ports are the same and are controlled by the SCON and SCON2 registers.

The serial port is full duplex, meaning it can transmit and receive simultaneously. It is also receive-buffered, meaning it can commence reception of a second byte before a previously received byte has been read from the register. (However, if the first byte still has not been read by the time reception of the second byte is complete, one of the bytes will be lost.) The serial port receive and transmit registers are both accessed at Special Function Register SBUF (or SBUF2 for the second serial port). Writing to SBUF loads the transmit register, and reading SBUF accesses a physically separate receive register.

The serial port can operate in 4 modes:

Mode 0. Serial data enters and exits through RxD. TxD outputs the shift clock. 8 bits are transmitted/received (LSB first). The baud rate is fixed at 1/6 the CPU clock frequency.

Mode 1. 10 bits are transmitted (through TxD) or received (through RxD): a start Bit (0), 8 data bits (LSB first), and a Stop Bit (1). On receive, the Stop Bit goes into RB8 in Special Function Register SCON. The baud rate is variable.

Mode 2. 11 bits are transmitted (through TxD) or received (through RxD): start Bit (0), 8 data bits (LSB first), a programmable 9th data bit, and a Stop Bit (1). On Transmit, the 9th data bit (TB8 in SCON) can be assigned the value of '0' or '1.' Or, for example, the Parity Bit (P, in the PSW) could be moved into TB8. On receive, the 9th data bit goes into RB8 in Special Function Register SCON, while the Stop Bit is ignored. The baud rate is programmable to either 1/32 or 1/64 the oscillator frequency.

Mode 3. 11 bits are transmitted (through TxD) or received (through RxD): a start Bit (0), 8 data bits (LSB first), a programmable 9th data bit, and a Stop Bit (1). In fact, Mode 3 is the same as Mode

2 in all respects except baud rate. The baud rate in Mode 3 is variable.

In all four modes, transmission is initiated by any instruction that uses SBUF as a destination register. Reception is initiated in Mode 0 by the condition RI = 0 and REN = 1. Reception is initiated in the other modes by the incoming start bit if REN = 1.

Multiprocessor Communications

Modes 2 and 3 have a special provision for multiprocessor communications. In these modes, 9 data bits are received. The 9th one goes into RB8. Then comes a Stop Bit. The port can be programmed such that when the Stop Bit is received, the serial port interrupt will be activated only if RB8 = 1. This feature is enabled by setting Bit SM2 in SCON. A way to use this feature in multi-processor systems is as follows:

When the master processor wants to transmit a block of data to one of several slaves, it first sends out an address byte which identifies the target slave. An address byte differs from a data byte in that the 9th bit is '1' in an address byte and 0 in a data byte. With SM2 = 1, no slave will be interrupted by a data byte. An address byte, however, will interrupt all slaves, so that each slave can examine the received byte and see if it is being addressed. The addressed slave will clear its SM2 Bit and prepare to receive the data bytes that will be coming. The slaves that weren't being addressed leave their SM2s set and go on about their business, ignoring the coming data bytes.

SM2 has no effect in Mode 0, and in Mode 1 can be used to check the validity of the Stop Bit. In a Mode 1 reception, if SM2 = 1, the receive interrupt will not be activated unless a valid Stop Bit is received.

Serial Port Control Register

The serial port control and status register is the Special Function Register SCON (SCON2 for the second port), shown in Figure 27. This register contains not only the mode selection bits, but also the 9th data bit for transmit and receive (TB8 and RB8), and the Serial Port Interrupt Bits (TI and RI).

Table 43. Serial Port Control Register (SCON)

7	6	5	4	3	2	1	0
SM0	SM1	SM2	REN	TB8	RB8	TI	RI



Table 44. Description of the SCON Bits

Bit	Symbol	Function
7	SM0	(SM1,SM0)=(0,0): Shift Register. Baud rate = $f_{OSC}/12$
6	SM1	(SM1,SM0)=(1,0): 8-bit UART. Baud rate = variable
		(SM1,SM0)=(0,1): 8-bit UART. Baud rate = $f_{OSC}/64$ or $f_{OSC}/32$
5	SM2	(SM1,SM0)=(1,1): 8-bit UART. Baud rate = variable
		Enables the multiprocessor communication features in Mode 2 and 3. In Mode 2 or 3, if SM2 is set to '1,' R1 will not be activated if its received 8th data bit (RB8) is '0.' In Mode 1, if SM2=1, R1 will not be activated if a valid Stop Bit was not received. In Mode 0, SM2 should be '0'
4	REN	Enables serial reception. Set by software to enable reception. Clear by software to disable reception
3	TB8	The 8th data bit that will be transmitted in Modes 2 and 3. Set or clear by software as desired
2	RB8	In Modes 2 and 3, this bit contains the 8th data bit that was received. In Mode 1, if SM2=0, RB8 is the Snap Bit that was received. In Mode 0, RB8 is not used
1	TI	Transmit interrupt flag. Set by hardware at the end of the 8th bit time in Mode 0, or at the beginning of the Stop Bit in the other modes, in any serial transmission. Must be cleared by software
0	RI	Receive interrupt flag. Set by hardware at the end of the 8th bit time in Mode 0, or halfway through the Stop Bit in the other modes, in any serial reception (except for SM2). Must be cleared by software

Baud Rates. The baud rate in Mode 0 is fixed:

$$\text{Mode 0 Baud Rate} = f_{osc} / 12$$

The baud rate in Mode 2 depends on the value of Bit SMOD = 0 (which is the value on reset), the baud rate is 1/64 the oscillator frequency. If SMOD = 1, the baud rate is 1/32 the oscillator frequency.

$$\text{Mode 2 Baud Rate} = (2^{SMOD} / 64) \times f_{osc}$$

In the μPSD325X devices, the baud rates in Modes 1 and 3 are determined by the Timer 1 overflow rate.

Using Timer 1 to Generate Baud Rates. When Timer 1 is used as the baud rate generator, the baud rates in Modes 1 and 3 are determined by the Timer 1 overflow rate and the value of SMOD as follows (see:

$$\text{Mode 1,3 Baud Rate} = (2^{SMOD} / 32) \times (\text{Timer 1 overflow Rate})$$

The Timer 1 interrupt should be disabled in this application. The Timer itself can be configured for either “timer” or “counter” operation, and in any of its 3 running modes. In the most typical applications, it is configured for “timer” operation, in the Auto-reload Mode (high nibble of TMOD = 0010B). In that case the baud rate is given by the formula:

$$\text{Mode 1,3 Baud Rate} = (2^{SMOD} / 32) \times (f_{osc} / 12 \times [256 - (TH1)])$$

One can achieve very low baud rates with Timer 1 by leaving the Timer 1 interrupt enabled, and configuring the Timer to run as a 16-bit timer (high nibble of TMOD = 0001B), and using the Timer 1 interrupt to do a 16-bit software reload. Figure 22 lists various commonly used baud rates and how they can be obtained from Timer 1.

Using Timer/Counter 2 to Generate Baud Rates. In the μPSD325X devices, Timer 2 selected as the baud rate generator by setting TCLK and/or RCLK (see Figure 22, page 55 Timer/Counter 2 Control Register (T2CON)).

Note: The baud rate for transmit and receive can be simultaneously different. Setting RCLK and/or TCLK puts Timer into its Baud Rate Generator Mode.

The RCLK and TCLK Bits in the T2CON register configure UART 1. The RCLK1 and TCLK1 Bits in the PCON register configure UART 2.

The Baud Rate Generator Mode is similar to the Auto-reload Mode, in that a roll over in TH2 causes the Timer 2 registers to be reloaded with the 16-bit value in registers RCAP2H and RCAP2L, which are preset by software.

Now, the baud rates in Modes 1 and 3 are determined at Timer 2’s overflow rate as follows:

$$\text{Mode 1,3 Baud Rate} = \text{Timer 2 Overflow Rate} / 16$$

Table 45. Timer 1-Generated Commonly Used Baud Rates

Baud Rate	fosc	SMOD	Timer 1		
			C/T	Mode	Reload Value
Mode 0 Max: 1MHz	12MHz	X	X	X	X
Mode 2 Max: 375K	12MHz	1	X	X	X
Modes 1, 3: 62.5K	12MHz	1	0	2	FFh
19.2K	11.059MHz	1	0	2	FDh
9.6K	11.059MHz	0	0	2	FDh
4.8K	11.059MHz	0	0	2	FAh
2.4K	11.059MHz	0	0	2	F4h
1.2K	11.059MHz	0	0	2	E8h
137.5	11.059MHz	0	0	2	1Dh
110	6MHz	0	0	2	72h
110	12MHz	0	0	1	FEEBh

The timer can be configured for either “timer” or “counter” operation. In the most typical applications, it is configured for “timer” operation ($C/T2 = 0$). “Timer” operation is a little different for Timer 2 when it’s being used as a baud rate generator. Normally, as a timer it would increment every machine cycle (thus at the 1/6 the CPU clock frequency). In the case, the baud rate is given by the formula:

Mode 1,3 Baud Rate = $f_{osc} / (32 \times [65536 - (RCAP2H, RCAP2L)])$

where (RCAP2H, RCAP2L) is the content of RC2H and RC2L taken as a 16-bit unsigned integer.

Timer 2 also be used as the Baud Rate Generating Mode. This mode is valid only if $RCLK + TCLK = 1$ in T2CON or in PCON.

Note: A roll-over in TH2 does not set TF2, and will not generate an interrupt. Therefore, the Timer interrupt does not have to be disabled when Timer 2 is in the Baud Rate Generator Mode.

Note: If EXEN2 is set, a 1-to-0 transition in T2EX will set EXF2 but will not cause a reload from (RCAP2H, RCAP2L) to (TH2, TL2). Thus when Timer 2 is in use as a baud rate generator, T2EX can be used as an extra external interrupt, if desired.

It should be noted that when Timer 2 is running ($TR2 = 1$) in “timer” function in the Baud Rate Generator Mode, one should not try to READ or WRITE TH2 or TL2. Under these conditions the timer is being incremented every state time, and the results of a READ or WRITE may not be accurate. The RC registers may be read, but should not be written to, because a WRITE might overlap a reload and cause WRITE and/or reload errors. Turn the timer off (clear TR2) before accessing the Timer 2 or RC registers, in this case.

More About Mode 0. Serial data enters and exits through RxD. TxD outputs the shift clock. 8 bits are transmitted/received: 8 data bits (LSB first). The baud rate is fixed a 1/6 the CPU clock frequency.

Figure 27, page 65 shows a simplified functional diagram of the serial port in Mode 0, and associated timing.

Transmission is initiated by any instruction that uses SBUF as a destination register. The “WRITE to SBUF” signal at S6P2 also loads a '1' into the 9th position of the transmit shift register and tells the TX Control block to commence a transmission. The internal timing is such that one full machine cycle will elapse between “WRITE to SBUF” and activation of SEND.

SEND enables the output of the shift register to the alternate out-put function line of RxD and also enable SHIFT CLOCK to the alternate output function line of TxD. SHIFT CLOCK is low during S3,

S4, and S5 of every machine cycle, and high during S6, S1, and S2. At S6P2 of every machine cycle in which SEND is active, the contents of the transmit shift are shifted to the right one position.

As data bits shift out to the right, zeros come in from the left. When the MSB of the data byte is at the output position of the shift register, then the '1' that was initially loaded into the 9th position, is just to the left of the MSB, and all positions to the left of that contain zeros. This condition flags the TX Control block to do one last shift and then deactivate SEND and set T1. Both of these actions occur at S1P1. Both of these actions occur at S1P1 of the 10th machine cycle after “WRITE to SBUF.”

Reception is initiated by the condition $REN = 1$ and $R1 = 0$. At S6P2 of the next machine cycle, the RX Control unit writes the bits 11111110 to the receive shift register, and in the next clock phase activates RECEIVE.

RECEIVE enables SHIFT CLOCK to the alternate output function line of TxD. SHIFT CLOCK makes transitions at S3P1 and S6P1 of every machine cycle in which RECEIVE is active, the contents of the receive shift register are shifted to the left one position. The value that comes in from the right is the value that was sampled at the RxD pin at S5P2 of the same machine cycle.

As data bits come in from the right, '1s' shift out to the left. When the '0' that was initially loaded into the right-most position arrives at the left-most position in the shift register, it flags the RX Control block to do one last shift and load SBUF. At S1P1 of the 10th machine cycle after the WRITE to SCON that cleared RI, RECEIVE is cleared as RI is set.

More About Mode 1. Ten bits are transmitted (through TxD), or received (through RxD): a start Bit (0), 8 data bits (LSB first), and a Stop Bit (1). On receive, the Stop Bit goes into RB8 in SCON. In the µPSD325X devices the baud rate is determined by the Timer 1 over-flow rate.

Figure 29 shows a simplified functional diagram of the serial port in Mode 1, and associated timings for transmit receive.

Transmission is initiated by any instruction that uses SBUF as a destination register. The “WRITE to SBUF” signal also loads a '1' into the 9th bit position of the transmit shift register and flags the TX Control unit that a transmission is requested. Transmission actually commences at S1P1 of the machine cycle following the next rollover in the divide-by-16 counter. (Thus, the bit times are synchronized to the divide-by-16 counter, not to the “WRITE to SBUF” signal.)

The transmission begins with activation of SEND which puts the start bit at TxD. One bit time later, DATA is activated, which enables the output bit of

the transmit shift register to TxD. The first shift pulse occurs one bit time after that.

As data bits shift out to the right, zeros are clocked in from the left. When the MSB of the data byte is at the output position of the shift register, then the '1' that was initially loaded into the 9th position is just to the left of the MSB, and all positions to the left of that contain zeros. This condition flags the TX Control unit to do one last shift and then deactivate SEND and set TI. This occurs at the 10th divide-by-16 rollover after "WRITE to SBUF."

Reception is initiated by a detected 1-to-0 transition at RxD. For this purpose RxD is sampled at a rate of 16 times whatever baud rate has been established. When a transition is detected, the divide-by-16 counter is immediately reset, and 1FFH is written into the input shift register. Resetting the divide-by-16 counter aligns its roll-overs with the boundaries of the incoming bit times.

The 16 states of the counter divide each bit time into 16ths. At the 7th, 8th, and 9th counter states of each bit time, the bit detector samples the value of RxD. The value accepted is the value that was seen in at least 2 of the 3 samples. This is done for noise rejection. If the value accepted during the first bit time is not '0,' the receive circuits are reset and the unit goes back to looking for an-other 1-to-0 transition. This is to provide rejection of false start bits. If the start bit proves valid, it is shifted into the input shift register, and reception of the rest of the frame will proceed.

As data bits come in from the right, '1s' shift out to the left. When the start bit arrives at the left-most position in the shift register (which in Mode 1 is a 9-bit register), it flags the RX Control block to do one last shift, load SBUF and RB8, and set RI. The signal to load SBUF and RB8, and to set RI, will be generated if, and only if, the following conditions are met at the time the final shift pulse is generated:

1. R1 = 0, and
2. Either SM2 = 0, or the received Stop Bit = 1.

If either of these two conditions is not met, the received frame is irretrievably lost. If both conditions are met, the Stop Bit goes into RB8, the 8 data bits go into SBUF, and RI is activated. At this time, whether the above conditions are met or not, the unit goes back to looking for a 1-to-0 transition in RxD.

More About Modes 2 and 3. Eleven bits are transmitted (through TxD), or received (through RxD): a Start Bit (0), 8 data bits (LSB first), a programmable 9th data bit, and a Stop Bit (1). On transmit, the 9th data bit (TB8) can be assigned the value of '0' or '1.' On receive, the data bit goes into RB8 in SCON. The baud rate is programmable to either 1/16 or 1/32 the CPU clock frequency

in Mode 2. Mode 3 may have a variable baud rate generated from Timer 1.

Figure 31, page 67 and Figure 33, page 68 show a functional diagram of the serial port in Modes 2 and 3. The receive portion is exactly the same as in Mode 1. The transmit portion differs from Mode 1 only in the 9th bit of the transmit shift register.

Transmission is initiated by any instruction that uses SBUF as a destination register. The "WRITE to SBUF" signal also loads TB8 into the 9th bit position of the transmit shift register and flags the TX Control unit that a transmission is requested. Transmission commences at S1P1 of the machine cycle following the next roll-over in the divide-by-16 counter. (Thus, the bit times are synchronized to the divide-by-16 counter, not to the "WRITE to SBUF" signal.)

The transmission begins with activation of SEND, which puts the start bit at TxD. One bit time later, DATA is activated, which enables the output bit of the transmit shift register to TxD. The first shift pulse occurs one bit time after that. The first shift clocks a '1' (the Stop Bit) into the 9th bit position of the shift register. There-after, only zeros are clocked in. Thus, as data bits shift out to the right, zeros are clocked in from the left. When TB8 is at the out-put position of the shift register, then the Stop Bit is just to the left of TB8, and all positions to the left of that contain zeros. This condition flags the TX Control unit to do one last shift and then deactivate SEND and set TI. This occurs at the 11th divide-by 16 rollover after "WRITE to SUBF."

Reception is initiated by a detected 1-to-0 transition at RxD. For this purpose RxD is sampled at a rate of 16 times whatever baud rate has been established. When a transition is detected, the divide-by-16 counter is immediately reset, and 1FFH is written to the input shift register.

At the 7th, 8th, and 9th counter states of each bit time, the bit detector samples the value of R-D. The value accepted is the value that was seen in at least 2 of the 3 samples. If the value accepted during the first bit time is not '0,' the receive circuits are reset and the unit goes back to looking for an-other 1-to-0 transition. If the Start Bit proves valid, it is shifted into the input shift register, and reception of the rest of the frame will proceed.

As data bits come in from the right, '1s' shift out to the left. When the Start Bit arrives at the left-most position in the shift register (which in Modes 2 and 3 is a 9-bit register), it flags the RX Control block to do one last shift, load SBUF and RB8, and set RI.

The signal to load SBUF and RB8, and to set RI, will be generated if, and only if, the following conditions are met at the time the final shift pulse is generated:

1. RI = 0, and
 2. Either SM2 = 0, or the received 9th data bit = 1
- If either of these conditions is not met, the received frame is irretrievably lost, and RI is not set. If both conditions are met, the received 9th data bit goes

into RB8, and the first 8 data bits go into SBUF. One bit time later, whether the above conditions were met or not, the unit goes back to looking for a 1-to-0 transition at the RxD input.

Figure 27. Serial Port Mode 0, Block Diagram

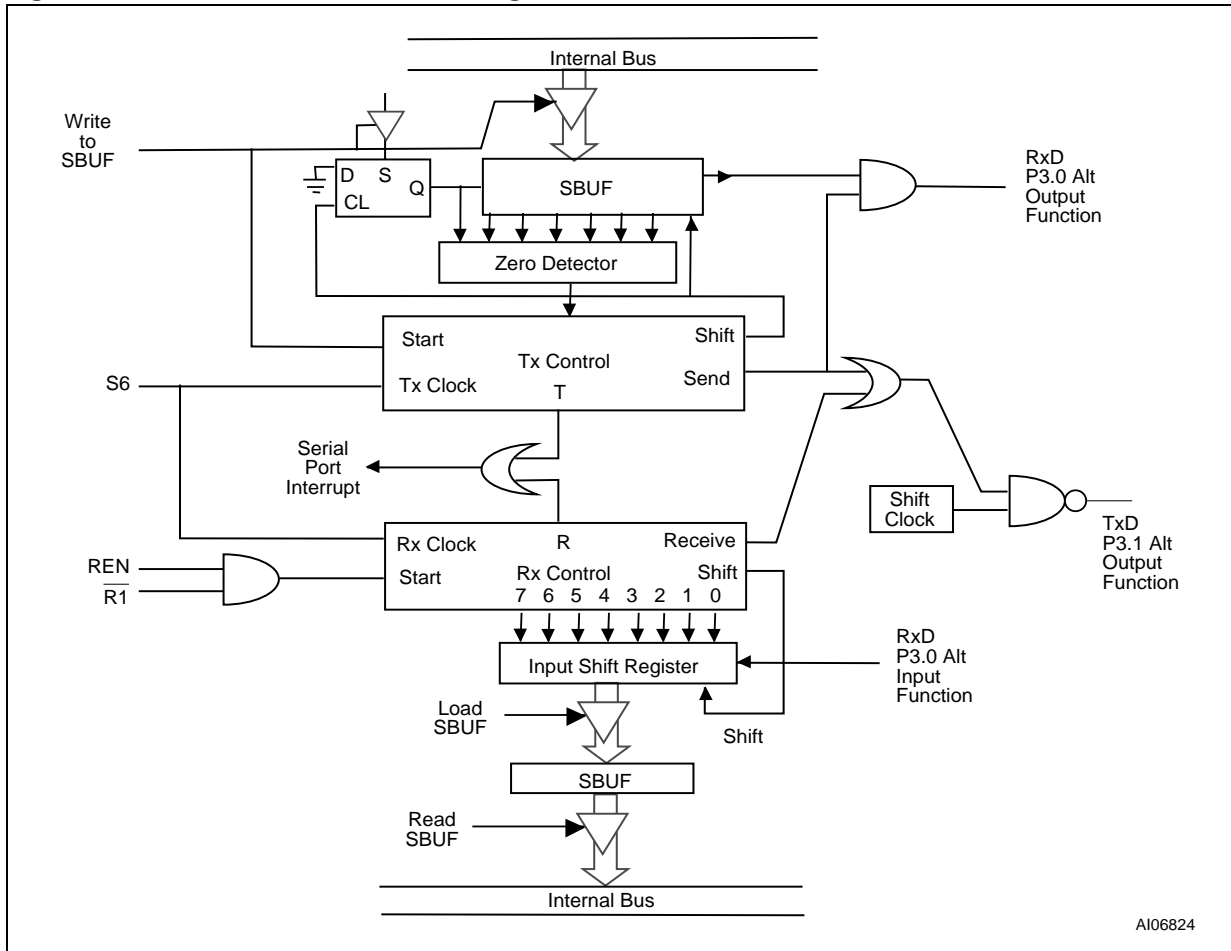

Figure 28. Serial Port Mode 0, Waveforms

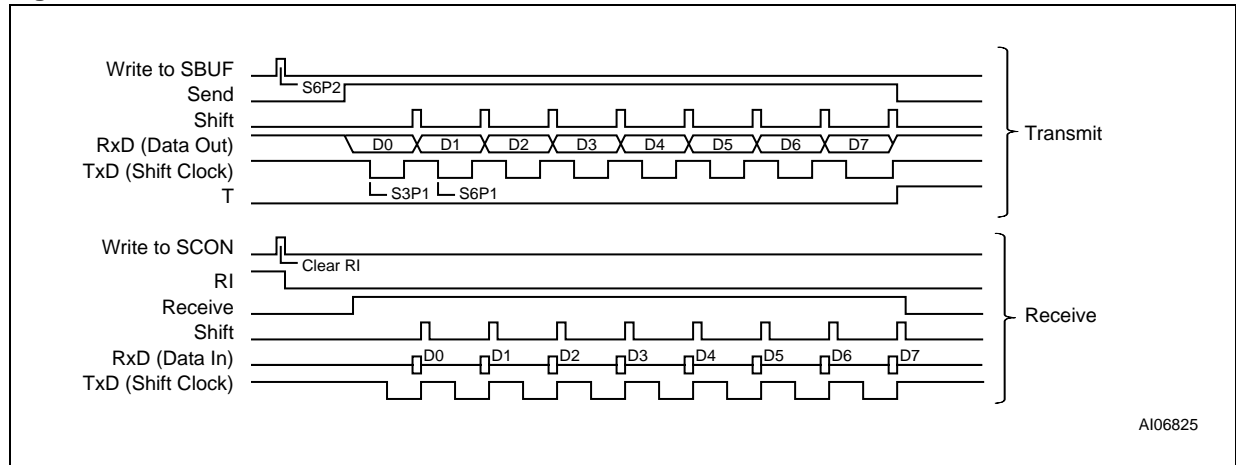

Figure 29. Serial Port Mode 1, Block Diagram

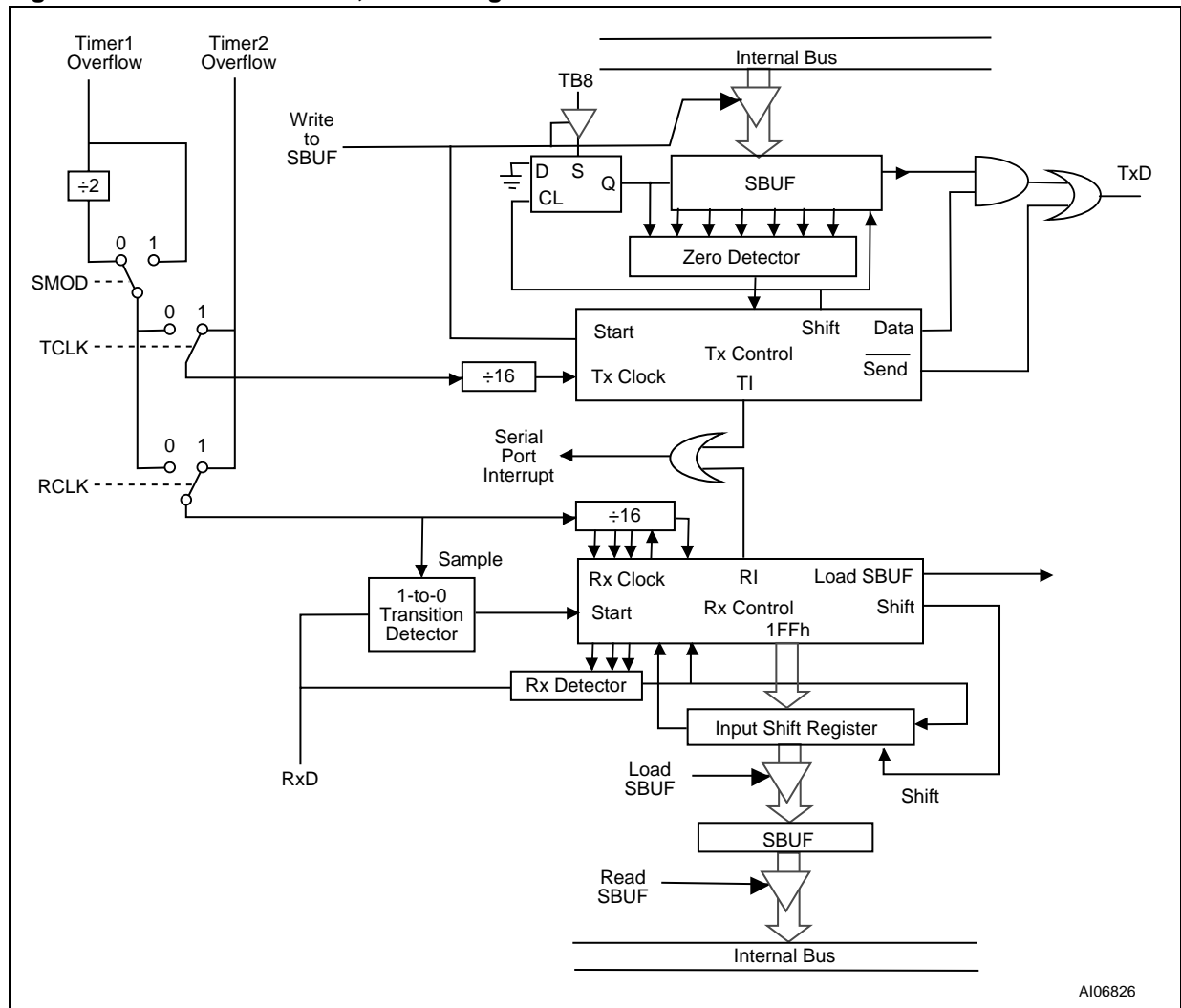

Figure 30. Serial Port Mode 1, Waveforms

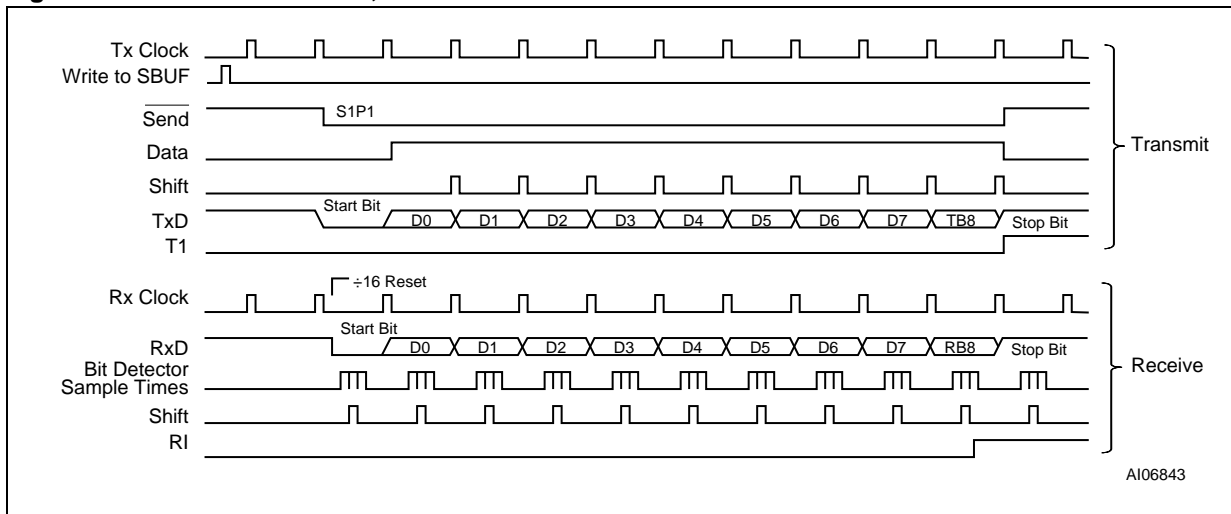

Figure 31. Serial Port Mode 2, Block Diagram

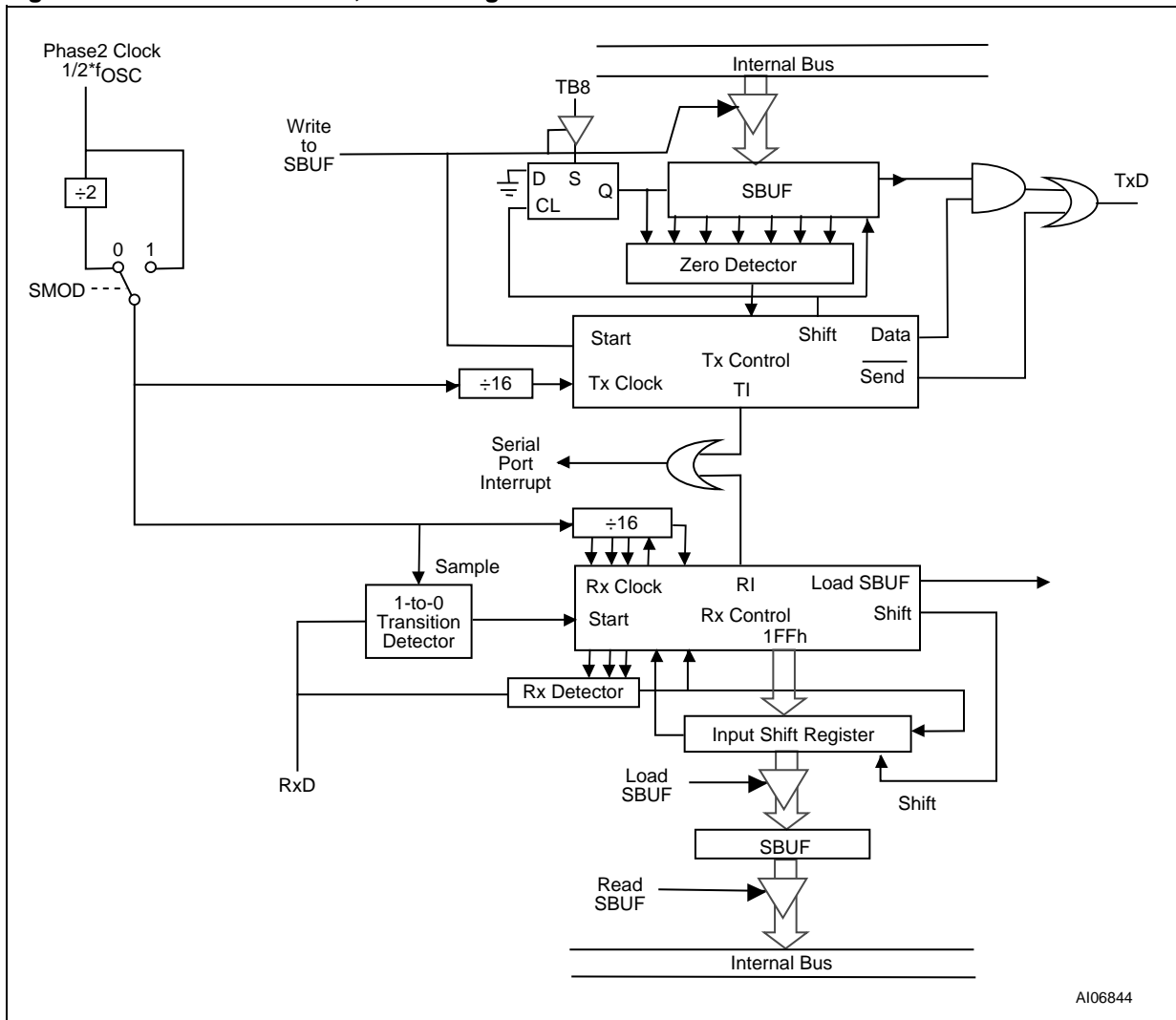

Figure 32. Serial Port Mode 2, Waveforms

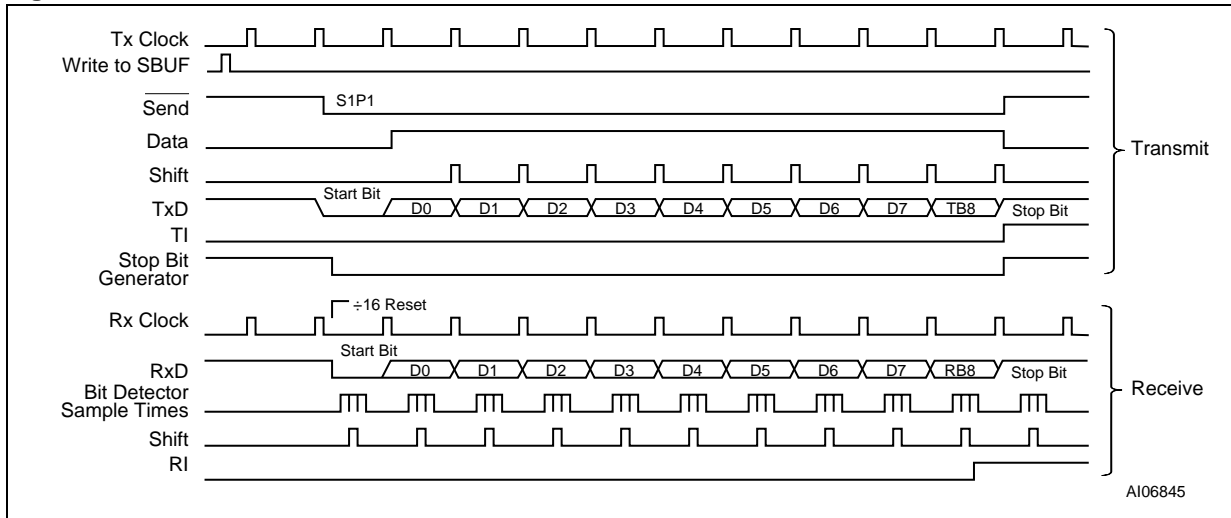

Figure 33. Serial Port Mode 3, Block Diagram

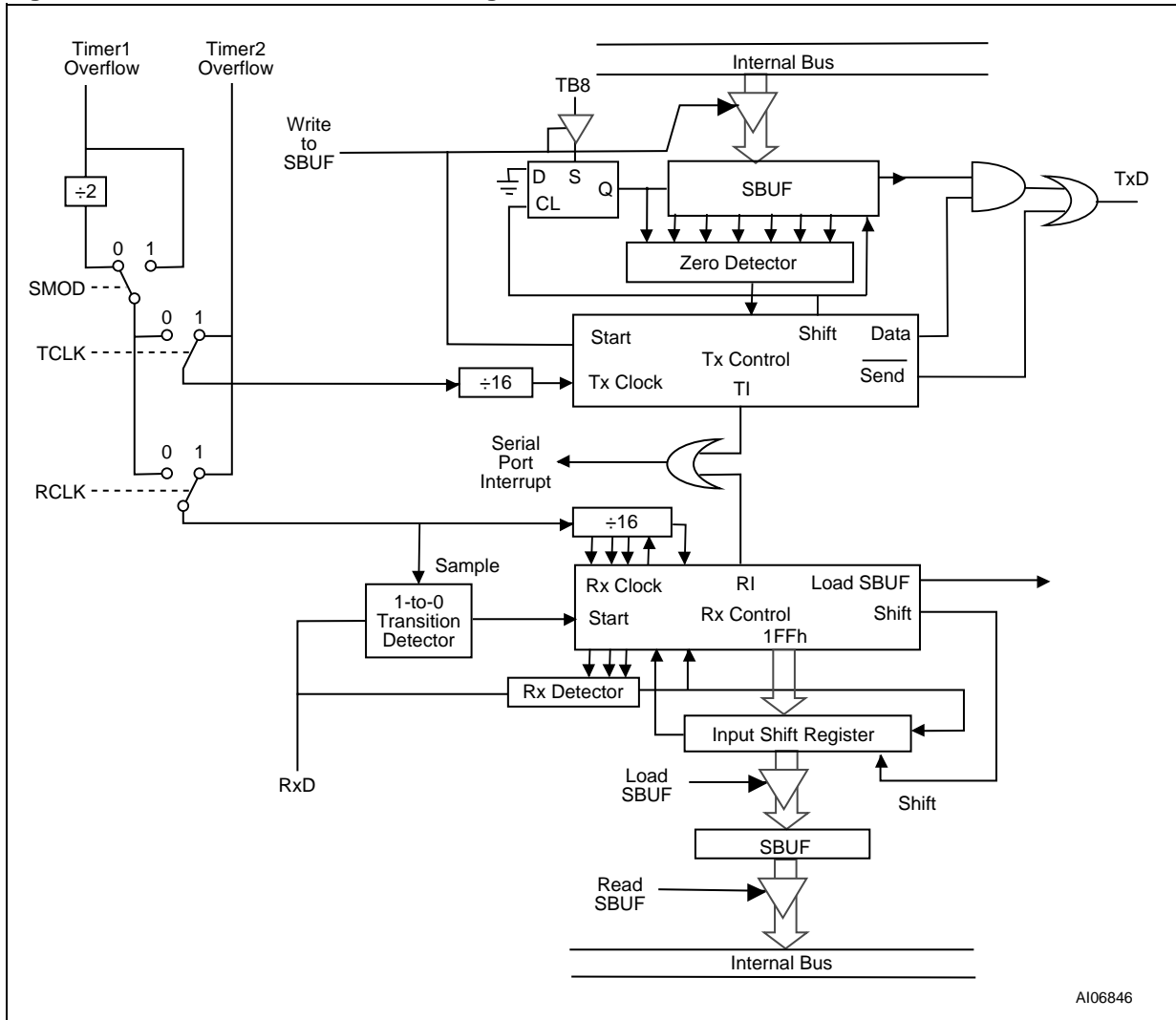
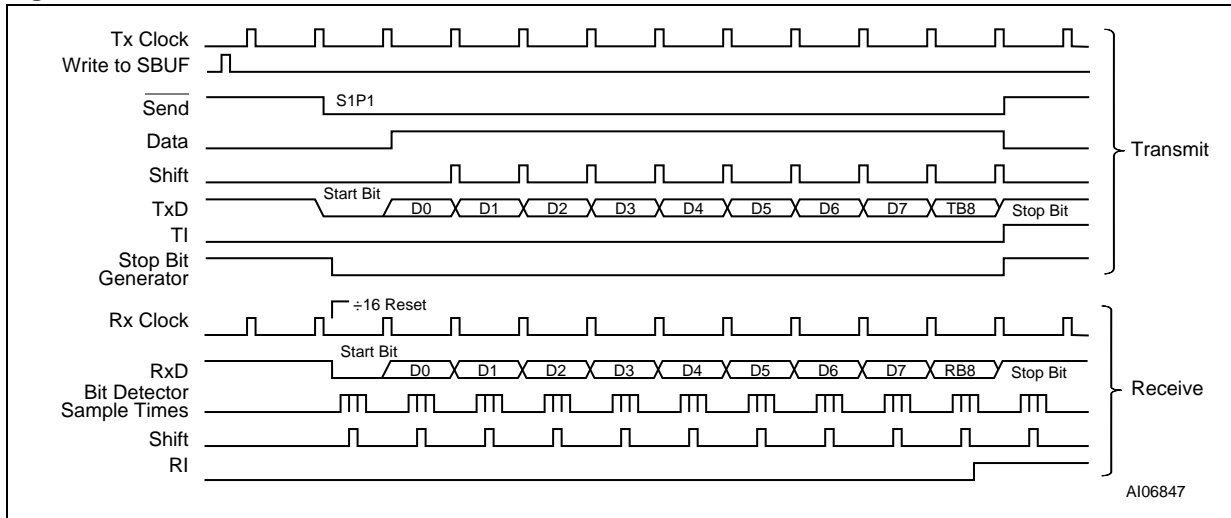

Figure 34. Serial Port Mode 3, Waveforms



ANALOG-TO-DIGITAL CONVERTOR (ADC)

The analog to digital (A/D) converter allows conversion of an analog input to a corresponding 8-bit digital value. The A/D module has four analog inputs, which are multiplexed into one sample and hold. The output of the sample and hold is the input into the converter, which generates the result via successive approximation. The analog supply voltage is connected to AVREF of ladder resistance of A/D module.

The A/D module has two registers which are the control register ACON and A/D result register ADAT. The register ACON, shown in Table 47, page 71, controls the operation of the A/D converter module. To use analog inputs, I/O is selected by P1SFS register. Also an 8-bit prescaler ASCL divides the main system clock input down to approximately 6MHz clock that is required for the ADC logic. Appropriate values need to be loaded into the prescaler based upon the main MCU clock frequency prior to use.

The processing of conversion starts when the Start Bit ADST is set to '1.' After one cycle, it is cleared by hardware. The register ADAT contains the results of the A/D conversion. When conversion is completed, the result is loaded into the ADAT the A/D Conversion Status Bit ADSF is set to '1.'

The block diagram of the A/D module is shown in Figure 35. The A/D Status Bit ADSF is set automatically when A/D conversion is completed, cleared when A/D conversion is in process.

The ASCL should be loaded with a value that results in a clock rate of approximately 6MHz for the ADC using the following formula:

$$\text{ADC clock input} = (\text{Fosc} / 2) / (\text{Prescaler register value} + 1)$$

Where Fosc is the MCU clock input frequency

The conversion time for the ADC can be calculated as follows:

$$\text{ADC Conversion Time} = 8 \text{ clock} * 8\text{bits} * (\text{ADC Clock}) \approx 10.67\text{usec (at 6MHz)}$$

ADC Interrupt

The ADSF Bit in the ACON register is set to '1' when the A/D conversion is complete. The status bit can be driven by the MCU, or it can be configured to generate a falling edge interrupt when the conversion is complete.

The ADSF interrupt is enabled by setting the ADSFINT Bit in the PCON register. Once the bit is set, the external INT1 interrupt is disabled and the ADSF interrupt takes over as INT1. INT1 must be configured as if it is an edge interrupt input. The INP1 pin (p3.3) is available for general I/O functions, or Timer1 gate control.

Figure 35. A/D Block Diagram

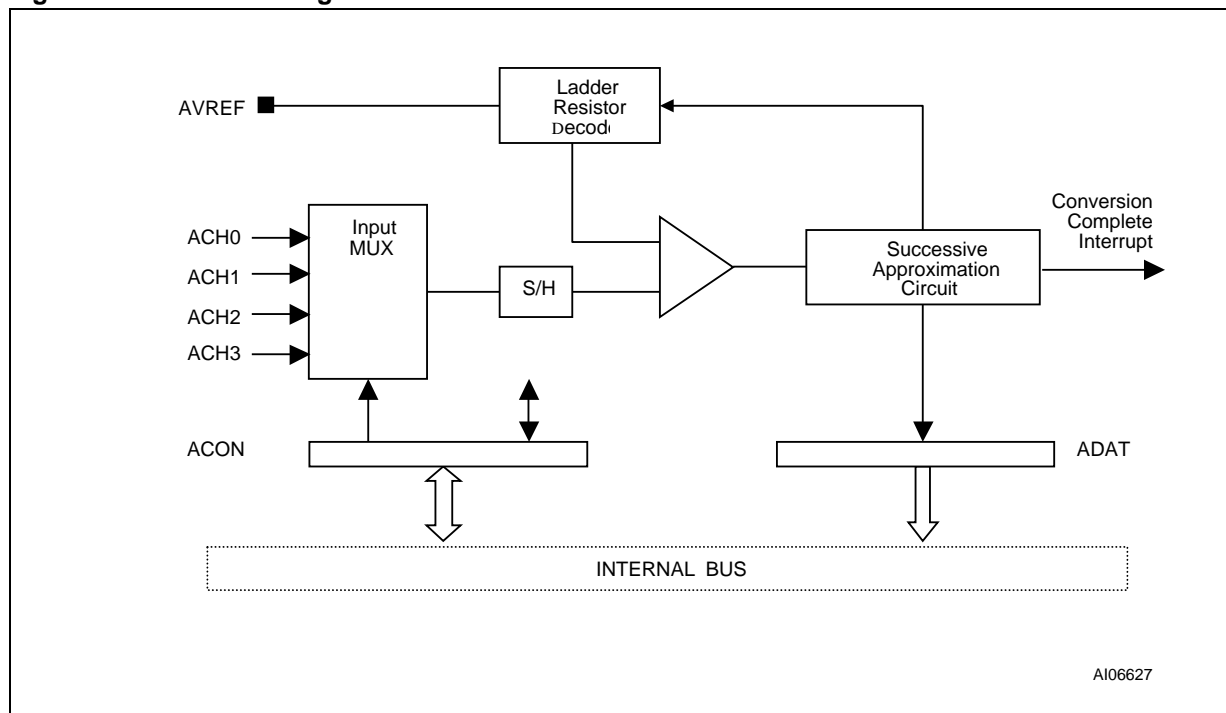

Table 46. ADC SFR Memory Map

SFR Addr	Reg Name	Bit Register Name								Reset Value	Comments
		7	6	5	4	3	2	1	0		
95	ASCL									00	8-bit Prescaler for ADC clock
96	ADAT	ADAT7	ADAT6	ADAT5	ADAT4	ADAT3	ADAT2	ADAT1	ADAT0	00	ADC Data Register
97	ACON			ADEN		ADS1	ADS0	ADST	ADSF	00	ADC Control Register

Table 47. Description of the ACON Bits

Bit	Symbol	Function
7 to 6	—	Reserved
5	ADEN	ADC Enable Bit: 0 : ADC shut off and consumes no operating current 1 : enable ADC
4	—	Reserved
3 to 2	ADS1, ADS0 0, 0 0, 1 1, 0 1, 1	Analog channel select Channel0 (ACH0) Channel1 (ACH1) Channel2 (ACH2) Channel3 (ACH3)
1	ADST	ADC Start Bit: 0 : force to zero 1 : start an ADC; after one cycle, bit is cleared to '0'
0	ADSF	ADC Status Bit: 0 : A/D conversion is in process 1 : A/D conversion is completed, not in process

Table 48. ADC Clock Input

MCU Clock Frequency	Prescaler Register Value	ADC Clock
40MHz	2	6.7MHz
36MHz	2	6MHz
24MHz	1	6MHz
12MHz	0	6MHz

PULSE WIDTH MODULATION (PWM)

The PWM block has the following features:

- Four-channel, 8-bit PWM unit with 16-bit prescaler
- One-channel, 8-bit unit with programmable frequency and pulse width
- PWM Output with programmable polarity

4-channel PWM unit (PWM 0-3)

The 8-bit counter of a PWM counts module 256 (i.e., from 0 to 255, inclusive). The value held in the 8-bit counter is compared to the contents of the Special Function Register (PWM 0-3) of the corresponding PWM. The polarity of the PWM outputs is programmable and selected by the PWML Bit in PWMCON register. Provided the contents of a PWM 0-3 register is greater than the counter value, the corresponding PWM output is set HIGH (with PWML = 0). When the contents of this register is less than or equal to the counter value, the corresponding PWM output is set LOW (with PWML = 0). The pulse-width-ratio is therefore de-

fined by the contents of the corresponding Special Function Register (PWM 0-3) of a PWM. By loading the corresponding Special Function Register (PWM 0-3) with either 00H or FFH, the PWM output can be retained at a constant HIGH or LOW level respectively (with PWML = 0).

For each PWM unit, there is a 16-bit Prescaler that are used to divide the main system clock to form the input clock for the corresponding PWM unit. This prescaler is used to define the desired repetition rate for the PWM unit. SFR registers B1h - B2h are used to hold the 16-bit divisor values.

The repetition frequency of the PWM output is given by:

$$f_{\text{PWM}_8} = (f_{\text{osc}} / \text{prescaler}_0) / (2 \times 256)$$

And the input clock frequency to the PWM counters is = $f_{\text{osc}} / 2 / (\text{prescaler data value} + 1)$

See the I/O PORTS (MCU Module), page 46 for more information on how to configure the Port 4 pin as PWM output.

Figure 36. Four-Channel 8-bit PWM Block Diagram

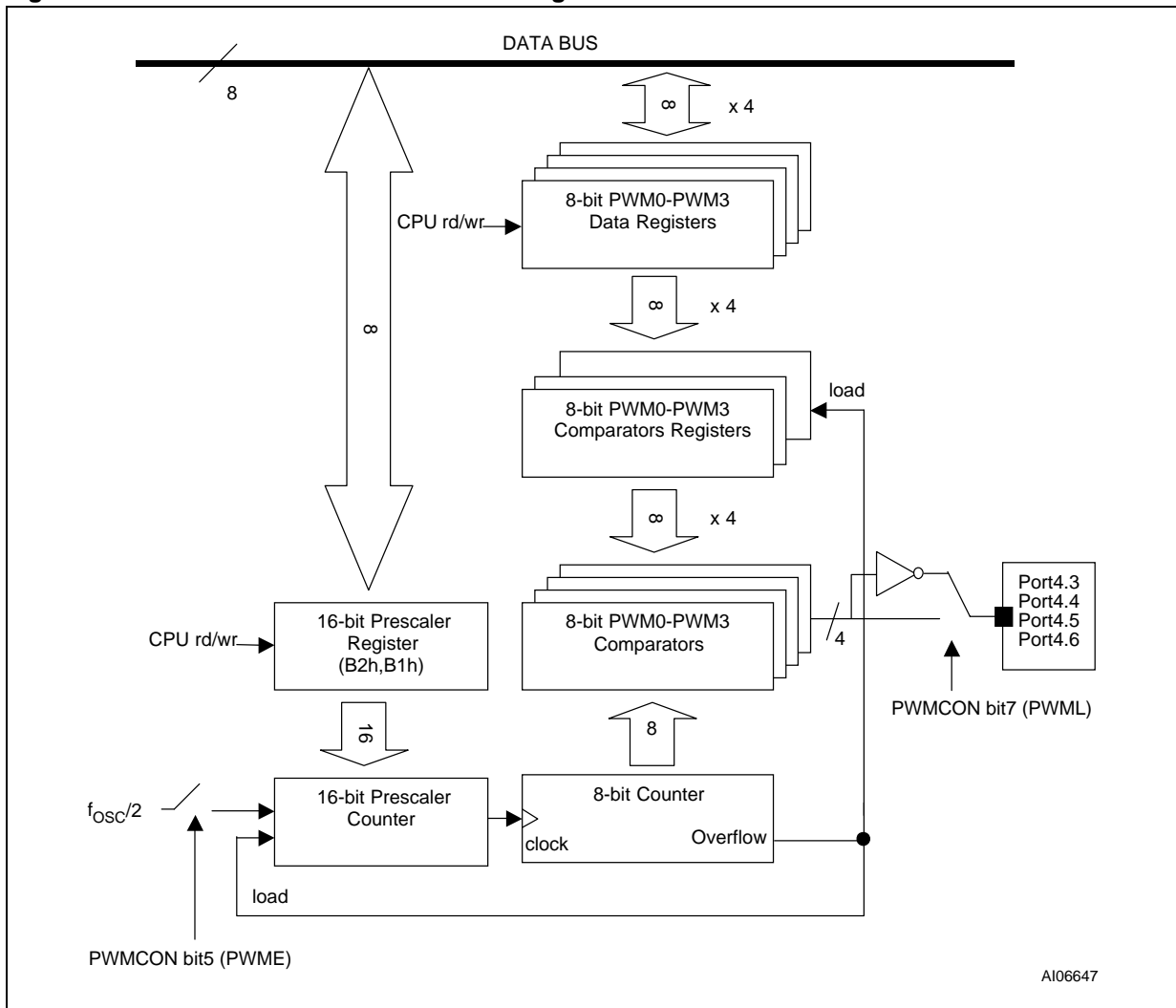

Table 49. PWM SFR Memory Map

SFR Addr	Reg Name	Bit Register Name								Reset Value	Comments
		7	6	5	4	3	2	1	0		
A1	PWMCON	PWML	PWMP	PWME	CFG4	CFG3	CFG2	CFG1	CFG0	00	PWM Control Polarity
A2	PWM0									00	PWM0 Output Duty Cycle
A3	PWM1									00	PWM1 Output Duty Cycle
A4	PWM2									00	PWM2 Output Duty Cycle
A5	PWM3									00	PWM3 Output Duty Cycle
AA	PWM4P									00	PWM 4 Period
AB	PWM4W									00	PWM 4 Pulse Width
B1	PSCL0L									00	Prescaler 0 Low (8-bit)
B2	PSCL0H									00	Prescaler 0 High (8-bit)
B3	PSCL1L									00	Prescaler 1 Low (8-bit)
B4	PSCL1H									00	Prescaler 1 High (8-bit)

PWMCON Register Bit Definition:

- PWML = PWM 0-3 polarity control
- PWMP = PWM 4 polarity control
- PWME = PWM enable (0 = disabled, 1= enabled)
- CFG3..CFG0 = PWM 0-3 Output (0 = Open Drain; 1 = Push-Pull)
- CFG4 = PWM 4 Output (0 = Open Drain; 1 = Push-Pull)

Programmable Period 8-bit PWM

The PWM 4 channel can be programmed to provide a PWM output with variable pulse width and period. The PWM 4 has a 16-bit Prescaler, an 8-bit Counter, a Pulse Width Register, and a Period Register. The Pulse Width Register defines the

PWM pulse width time, while the Period Register defines the period of the PWM. The input clock to the Prescaler is $f_{OSC}/2$. The PWM 4 channel is assigned to Port 4.7.

Figure 37. Programmable PWM 4 Channel Block Diagram

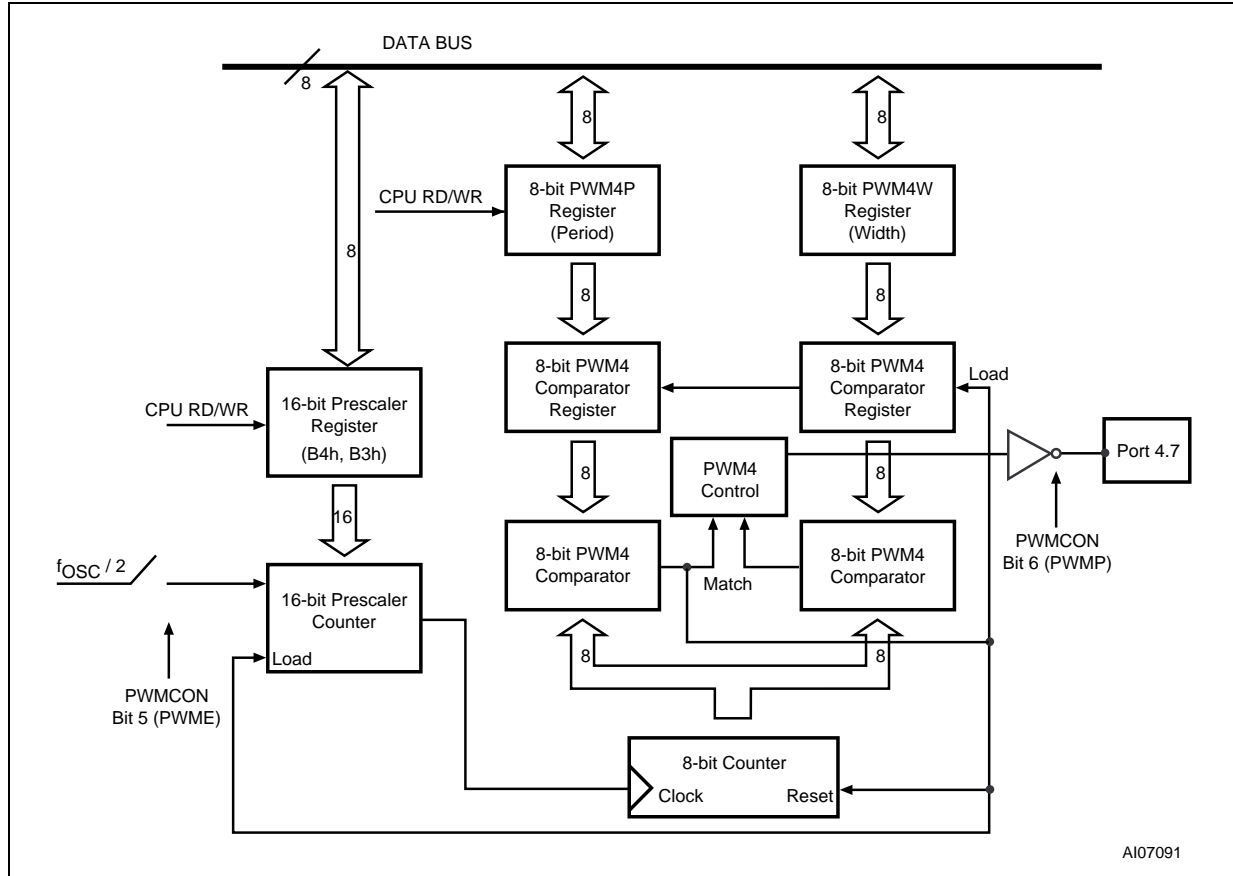

PWM 4 Channel Operation

The 16-bit Prescaler1 divides the input clock ($f_{OSC}/2$) to the desired frequency, the resulting clock runs the 8-bit Counter of the PWM 4 channel. The input clock frequency to the PWM 4 Counter is:

$$f_{PWM4} = (f_{OSC}/2) / (\text{Prescaler1 data value} + 1)$$

When the Prescaler1 Register (B4h, B3h) is set to data value '0,' the maximum input clock frequency to the PWM 4 Counter is $f_{OSC}/2$ and can be as high as 20MHz.

The PWM 4 Counter is a free-running, 8-bit counter. The output of the counter is compared to the Compare Registers, which are loaded with data from the Pulse Width Register (PWM4W, ABh) and the Period Register (PWM4P, AAh). The Pulse Width Register defines the pulse duration or the Pulse Width, while the Period Register defines the period of the PWM. When the PWM 4 channel is enabled, the register values are loaded into the Comparator Registers and are compared to the

Counter output. When the content of the counter is equal to or greater than the value in the Pulse Width Register, it sets the PWM 4 output to low (with PWMP Bit = 0). When the Period Register equals to the PWM4 Counter, the Counter is cleared, and the PWM 4 channel output is set to logic 'high' level (beginning of the next PWM pulse).

The Period Register cannot have a value of "00" and its content should always be greater than the Pulse Width Register.

The Prescaler1 Register, Pulse Width Register, and Period Register can be modified while the PWM 4 channel is active. The values of these registers are automatically loaded into the Prescaler Counter and Comparator Registers when the current PWM 4 period ends.

The PWMCON Register (Bits 5 and 6) controls the enable/disable and polarity of the PWM 4 channel.

Figure 38. PWM 4 With Programmable Pulse Width and Frequency

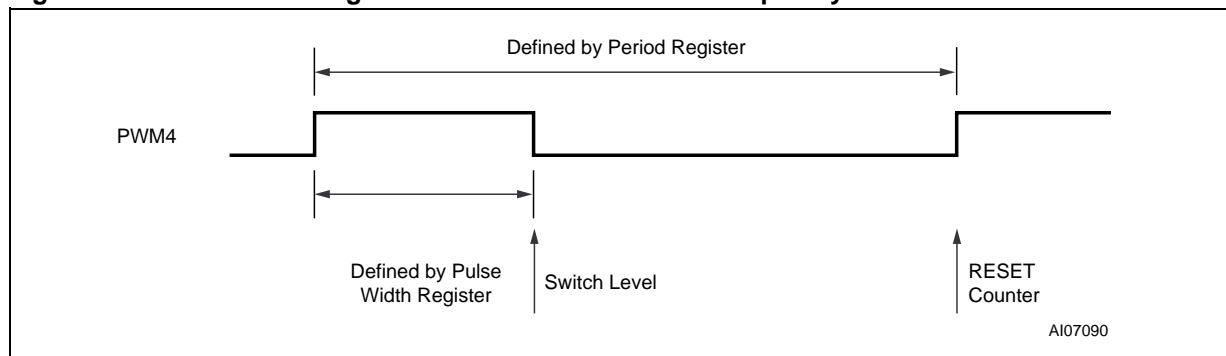

I²C INTERFACE

There are two serial I²C ports implemented in the μPSD325X devices.

The serial port supports the twin line I²C-bus, consists of a data line (SDAx) and a clock line (SCLx). Depending on the configuration, the SDA and SCL lines may require pull-up resistors.

- SDA1, SCL1: the serial port line for DDC Protocol
- SDA2, SCL2: the serial port line for general I²C bus connection

In both I²C interfaces, these lines also function as I/O port lines as follows.

- SDA1 / P4.0, SCL1 / P4.1, SDA2 / P3.6, SCL2 / P3.7

The system is unique because data transport, clock generation, address recognition and bus control arbitration are all controlled by hardware.

The I²C serial I/O has complete autonomy in byte handling and operates in 4 modes.

- Master transmitter
- Master receiver
- Slave transmitter
- Slave receiver

These functions are controlled by the SFRs.

- SxCON: the control of byte handling and the operation of 4 mode.
- SxSTA: the contents of its register may also be used as a vector to various service routines.
- SxDAT: data shift register.
- SxADR: slave address register. Slave address recognition is performed by On-Chip H/W.

Figure 39. Block Diagram of the I²C Bus Serial I/O

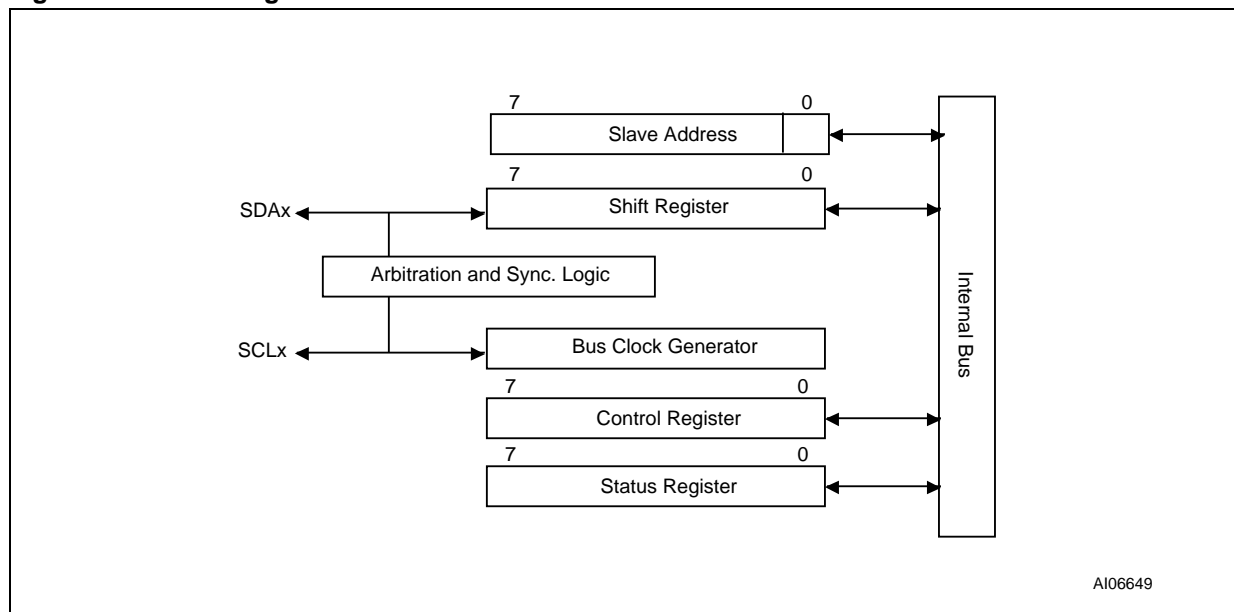

AI06649

µPSD325X DEVICES

Table 50. Serial Control Register (SxCON: S1CON, S2CON)

7	6	5	4	3	2	1	0
CR2	ENII	STA	STO	ADDR	AA	CR1	CR0

Table 51. Description of the SxCON Bits

Bit	Symbol	Function
7	CR2	This bit along with Bits CR1 and CR0 determines the serial clock frequency when SIO is in the Master Mode.
6	ENII	Enable IIC. When ENII = 0, the IIC is disabled. SDA and SCL outputs are in the high impedance state.
5	STA	START flag. When this bit is set, the SIO H/W checks the status of the I ² C-bus and generates a START condition if the bus is free. If the bus is busy, the SIO will generate a repeated START condition when this bit is set.
4	STO	STOP flag. With this bit set while in Master Mode a STOP condition is generated. When a STOP condition is detected on the I ² C-bus, the I ² C hardware clears the STO flag. Note: This bit has to be set before 1 cycle interrupt period of STOP. That is, if this bit is set, STOP condition in Master Mode is generated after 1 cycle interrupt period.
3	ADDR	This bit is set when address byte was received. Must be cleared by software.
2	AA	Acknowledge enable signal. If this bit is set, an acknowledge (low level to SDA) is returned during the acknowledge clock pulse on the SCL line when: <ul style="list-style-type: none"> • Own slave address is received • A data byte is received while the device is programmed to be a Master Receiver • A data byte is received while the device is a selected Slave Receiver. When this bit is reset, no acknowledge is returned. SIO releases SDA line as high during the acknowledge clock pulse.
1	CR1	These two bits along with the CR2 Bit determine the serial clock frequency when SIO is in the Master Mode.
0	CR0	

Table 52. Selection of the Serial Clock Frequency SCL in Master Mode

CR2	CR1	CR0	Fosc Divisor	Bit Rate (kHz) at Fosc			
				12MHz	24MHz	36MHz	40MHz
0	0	0	16	375	750	X	X
0	0	1	24	250	500	750	833
0	1	0	30	200	400	600	666
0	1	1	60	100	200	300	333
1	0	0	120	50	100	150	166
1	0	1	240	25	50	75	83
1	1	0	480	12.5	25	37.5	41
1	1	1	960	6.25	12.5	18.75	20

Serial Status Register (SxSTA: S1STA, S2STA)

SxSTA is a “Read-only” register. The contents of this register may be used as a vector to a service routine. This optimized the response time of the software and consequently that of the I²C-bus. The status codes for all possible modes of the I²C-bus interface are given Table 54.

This flag is set, and an interrupt is generated, after any of the following events occur.

1. Own slave address has been received during AA = 1: ack_int
2. The general call address has been received while GC(SxADR.0) = 1 and AA = 1:

3. A data byte has been received or transmitted in Master Mode (even if arbitration is lost): ack_int
4. A data byte has been received or transmitted as selected slave: ack_int
5. A stop condition is received as selected slave receiver or transmitter: stop_int

Data Shift Register (SxDAT: S1DAT, S2DAT)

SxDAT contains the serial data to be transmitted or data which has just been received. The MSB (Bit 7) is transmitted or received first; that is, data shifted from right to left.

Table 53. Serial Status Register (SxSTA)

7	6	5	4	3	2	1	0
GC	STOP	INTR	TX_MODE	BBUSY	BLOST	/ACK_REP	SLV

Table 54. Description of the SxSTA Bits

Bit	Symbol	Function
7	GC	General Call Flag
6	STOP	Stop Flag. This bit is set when a STOP condition is received
5	INTR	Interrupt Flag. This bit is set when an I ² C Interrupt condition is requested
4	TX_MODE	Transmission Mode Flag. This bit is set when the I ² C is a transmitter; otherwise this bit is reset
3	BBUSY	Bus Busy Flag. This bit is set when the bus is being used by another master; otherwise, this bit is reset
2	BLOST	Bus Lost Flag. This bit is set when the master loses the bus contention; otherwise this bit is reset
1	/ACK_REP	Acknowledge Response Flag. This bit is set when the receiver transmits the not acknowledge signal This bit is reset when the receiver transmits the acknowledge signal
0	SLV	Slave Mode Flag. This bit is set when the I ² C plays role in the Slave Mode; otherwise this bit is reset

Note: 1. Interrupt Flag Bit (INTR, SxSTA Bit 5) is cleared by Hardware as reading SxSTA register.
 2. I²C interrupt flag (INTR) can occur in below case. (except DDC2B Mode at SWENB=0)

Table 55. Data Shift Register (SxDAT: S1DAT, S2DAT)

7	6	5	4	3	2	1	0
SxDAT7	SxDAT6	SxDAT5	SxDAT4	SxDAT3	SxDAT2	SxDAT1	SxDAT0

μPSD325X DEVICES

Address Register (SxADR: S1ADR, S2ADR)

This 8-bit register may be loaded with the 7-bit slave address to which the controller will respond when programmed as a slave receive/transmitter.

The Start/Stop Hold Time Detection and System Clock registers (Tables 57 and 58) are included in

the I²C unit to specify the start/stop detection time to work with the large range of MCU frequency values supported. For example, with a system clock of 40MHz.

Table 56. Address Register (SxADR)

7	6	5	4	3	2	1	0
SLA6	SLA5	SLA4	SLA3	SLA2	SLA1	SLA0	—

Note: 1. SLA6 to SLA0: Own slave address.

Table 57. Start /Stop Hold Time Detection Register (S1SETUP, S2SETUP)

	Address	Register Name	Reset Value	Note
SFR	D1h	S1SETUP	00h	To control the start/stop hold time detection for the DDC module in Slave Mode
	D2h	S2SETUP	00h	To control the start/stop hold time detection for the multi-master I ² C module in Slave Mode

Table 58. System Cock of 40MHz

S1SETUP, S2SETUP Register Value	Number of Sample Clock ($f_{osc}/2 \rightarrow 50ns$)	Required Start/ Stop Hold Time	Note
00h	1EA	50ns	When Bit 7 (enable bit) = 0, the number of sample clock is 1EA (ignore Bit 6 to Bit 0)
80h	1EA	50ns	
81h	2EA	100ns	
82h	3EA	150ns	
...	
8Bh	12EA	600ns	Fast Mode I ² C Start/Stop hold time specification
...	
FFh	128EA	6000ns	

Table 59. System Clock Setup Examples

System Clock	S1SETUP, S2SETUP Register Value	Number of Sample Clock	Required Start/Stop Hold Time
40MHz ($f_{osc}/2 \rightarrow 50ns$)	8Bh	12 EA	600ns
30MHz ($f_{osc}/2 \rightarrow 66.6ns$)	89h	9 EA	600ns
20MHz ($f_{osc}/2 \rightarrow 100ns$)	86h	6 EA	600ns
8MHz ($f_{osc}/2 \rightarrow 250ns$)	83h	3 EA	750ns

Programmer's Guide for I²C and DDC2

The I²C serial I/O and DDC Interface operates in four modes.

- Master transmitter
- Master receiver
- Slave transmitter
- Slave receiver

Master transmitter mode flow.

1. Read SxSTA.
2. If BBUSY == 1 then
 go to step1.
 Else then
 write slave address to SxDAT and set both ENI and STA, reset AA in SxCON.
3. Wait for interrupt.
4. Read SxSTA.
 If BLOST == 1 or /ACK_REP == 1* then
 write dummy data to SxDAT.
 Go to step1.
 Else then
 clear STA.
5. Perform required service routines.
 If this datum == LAST then
 set STO in SxCON and write last data to SxDAT**.
 Go to step 6.

Else then

write next data to SxDAT**.

Go to step3.

6. Wait for interrupt.

Write dummy data to SxDAT**.

- Note: 1. (*) If the master don't receive the acknowledge from the slave, it generates the STOP condition and returns to the IDLE state.
 2. (**) This action should be the last in service routine.

Slave transmitter mode flow.

1. Write slave address to SxADR, set AA and ENI in SxCON.
2. Wait for interrupt.
3. Read SxSTA and write the first data to SxDAT*.
 Reset AA in SxCON.
4. Wait for interrupt.
5. Read SxSTA.
 If /ACK_REP == 1** then
 Go to step7.
 Else then
 write the next SxDAT*.
 Go to step5.
6. Write dummy data to SxDAT*.

- Note: 1. (*) These actions should be the last.
 2. (**) If the master want to stop the current data requests, it don't have to acknowledge to the slave transmitter.
 3. If the slave does not receive the acknowledge from the master, it releases the SDA and enters the IDLE state, so if the master is to resume the data requests, it must re-generate the START condition.

Master receiver mode flow.

1. Read SxSTA.
2. If BBUSY == 1 then
 go to step1.
 Else then
 write slave address to SxDAT and set both ENI1 and STA, reset AA in SxCON.
3. Wait for interrupt.
4. Read SxSTA.
 If BLOST == 1 or /ACK_REP == 1 then
 write dummy data to SxDAT
 Go to step1.
 Else then
 clear STA and write FFH to SxDAT.
 Set AA in SxCON.
5. Wait for interrupt.
6. Read SxSTA.
 If this datum == LAST then
 reset AA* and read SxDAT**.
 Go to step7.
 Else then
 read SxDAT**.
 Go to step5.
7. Wait for interrupt.
 Read SxSTA.
 Read SxDAT**.

Note: 1. (*) If the master want to terminate the current data requests, it don't have to acknowledge to the slave.
2. (**) This action should be the last.

Slave transmitter mode.

1. Write slave address to SxADR, set AA and ENI in SxCON.
2. Wait for interrupt.
3. Read SxSTA and write FFH to SxDAT*.
- 4.
5. Wait for interrupt.
6. Read SxSTA.
 If STOP == 1 then
 Go to step7.
 Else then
 read data from SxDAT*.
 Go to step5.
7. Read dummy data from SxDAT*.

Note: 1. (*) This action should be the last.

Special Function Register for the DDC Interface

There are eight SFR in the DDC interface: RAMBUF, DDCCON, DDCADR, DDCCDAT are DDC registers.

S1CON, S1STA, S1DAT, S1ADR are I²C Interface registers, same as the ones described in the standalone I²C bus.

DDCCDAT Register. DDC1 DATA register for transmission (DDCCDAT: 0D5H)

- 8-bit READ and WRITE register.
- Indicates DATA BYTE to be transmitted in DDC1 protocol.

DDCADR Register. Address pointer for DDC interface (DDCADR: 0D6H)

- 8-bit READ and WRITE register.
- Address pointer with the capability of the post increment. After each access to RAMBUF register (either by software or by hardware DDC1 interface), the content of this register will be increased by one. It's available both in DDC1, DDC2 (DDC2B, DDC2B+, and DDC2AB) and system operation.

Table 60. DDC SFR Memory Map

SFR Addr	Reg Name	Bit Register Name								Reset Value	Comments
		7	6	5	4	3	2	1	0		
D4	RAMBUF									XX	DDC Ram Buffer
D5	DDCCDAT									00	DDC Data xmit register
D6	DDCADR									00	Addr pointer register
D7	DDCCON	—	EX_DAT	SWENB	DDC_AX	DDCINT	DDC1EN	SWHINT	M0	00	DDC Control Register

Table 61. Description of the DDCON Register Bits

Bit	Symbol	Function
7	—	Reserved
6	EX_DAT	0 = The SRAM has 128 bytes (Default) 1 = The SRAM has 256 bytes
5	SWENB	Note: This bit is valid for DDC1 & DDC2b Modes 0 = Data is automatically read from SRAM at the current location of DDCADR and sent out via current DDC protocol. (Default) 1 = MCU is interrupted during the current data byte transmission period to load the next byte of data to send out.
4	DDC_AX	Note: This bit is valid for DDC1 & DDC2b Modes 0 = Data is automatically read from SRAM at the current location of DDCADR and sent out via current DDC protocol. (Default) 1 = MCU is interrupted during the current data byte transmission period to load the next byte of data to send out. This bit only affects DDC2b Mode Operation: 0 = DDC2b I2C Address is A0/A1 (default) 1 = DDC2b I2C Address is AX. Least 3 significant address bits are ignored.
3	DDC1_Int	For DDC1 Mode Operation Only: 0 = No DDC1 interrupt 1 = DDC1 Interrupt request. Set by HW and should be cleared by SW interrupt service routine. Note1: This bit is set in the 9th V _{CLK} at DDC1 Enable Mode. (SWENB=1)
2	DDC1EN	0 = DDC1 Mode is disabled – V _{SYNC} is ignored. The DDC unit will still respond to DDC2b requests. –provided I2C enabled.(Default) 1 = DDC1 Mode is enabled.
1	SWHINT	Set by hardware when the DDC unit switches from DDC1 to DDC2b Modes. 0 = No interrupt request. 1 = Switch to DDC2b Mode (Interrupt pending) Set by HW and should be cleared by SW interrupt service routine. Note1: This bit has no connection with SWENB.
0	Mode	Current Mode Indication Bit: 0 = Unit is in DDC1 Mode 1 = Unit is in DDC2b Mode Note: When the DDC unit transitions to DDC2b Mode, the DDC unit will stay in DDC2b Mode until the DDC unit is disabled, or the system is reset.

Table 62. SWNEB Bit Function

SWNEB	DDC1 or DDC2b Mode Disabled	DDC1 or DDC2b Mode Enabled
	DDCCON.bit2 = 0 (DDC1 Mode Disable) or S1CON.bit6 = 0 (I ² C Mode Disable)	DDCCON.bit2 = 1 (DDC1 Mode Enable) or S1CON.bit6 = 1 (I ² C Mode Enable)
0	In this state, the DDC unit is disabled. The DDC SRAM cannot be accessed by the MCU. No MCU interrupt and no DDC activity will occur. MCU cannot access internal DDC SRAM: DDC SRAM address space is re-assigned to external data space.	In this state, the DDC is enabled and the unit is in automatic mode. The DDC SRAM cannot be accessed by the MCU – only the DDC unit has access. MCU cannot access internal DDC SRAM: data space FF00h-FFFFh is dedicated to DDC SRAM.
1	In this state, the DDC unit is disabled, BUT with SWNEB=1, the MCU can access the SRAM. This state is used to load the DDC SRAM with the correct data for automatic modes. No MCU interrupt and no DDC activity will occur. MCU can access DDC SRAM: data space FF00h-FFFFh is dedicated to DDC SRAM.	In this state, the DDC SRAM can be accessed by the MCU. The DDC unit does not use the DDC SRAM when SWNEB=1. Since the DDC unit is in manual mode, the DDC unit generates an MCU interrupt for each byte transferred. The byte transferred is held in the I ² C S1DAT SFR register. MCU can access DDC SRAM.

Host Type Detection

The detection procedure conforms to the sequences proposed by VESA Monitor Display Data Channel (DDC) specification. The monitor needs to determine the type of host system:

- DDC1 or OLD type host.
- DDC2B host (Host is master, monitor is always slave)
- DDC2B+/DDC2AB(Access.bus) host.

Figure 41. Host Type Detection

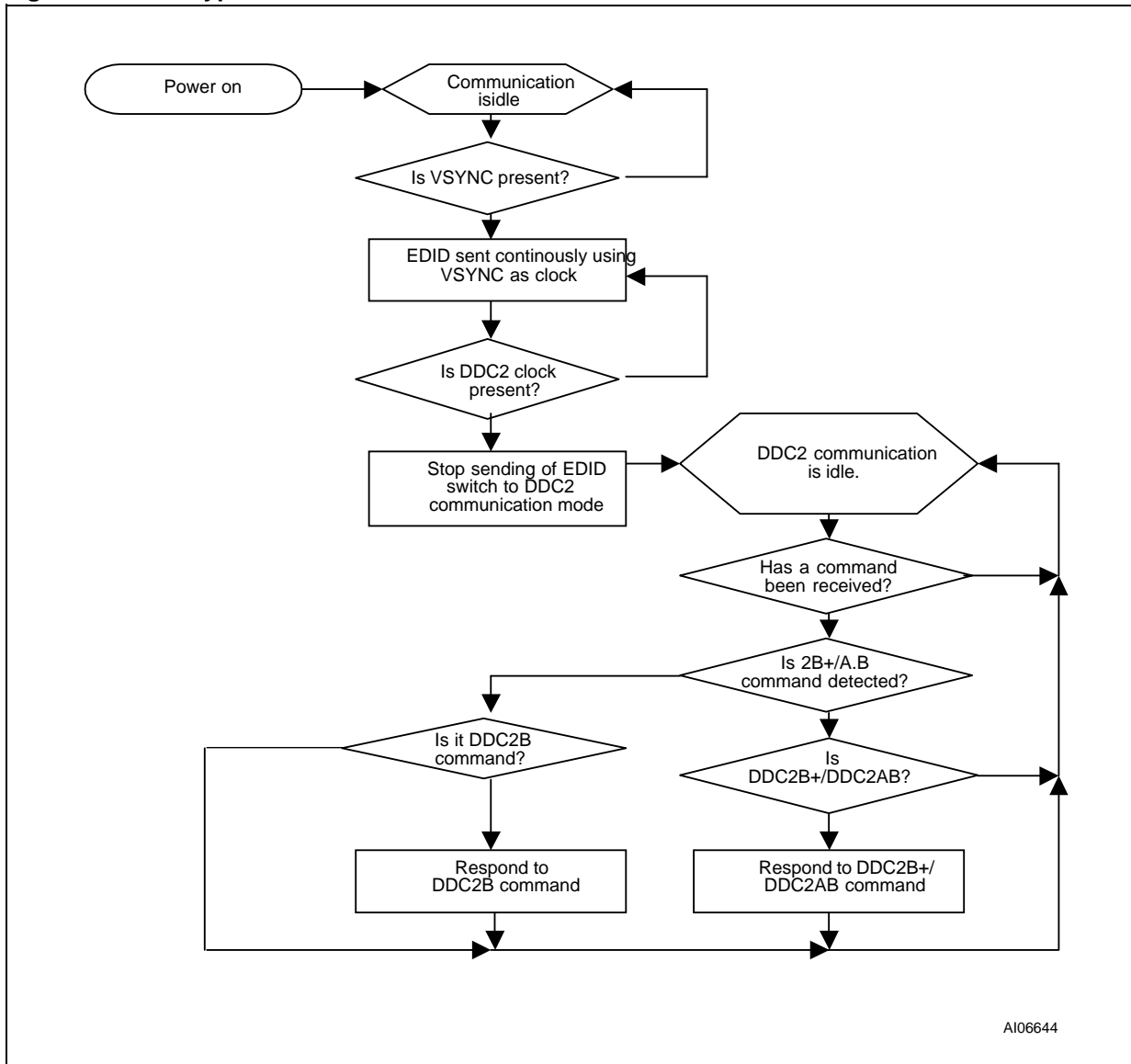

AI06644

DDC1 Protocol

DDC1 is primitive and a point to point interface. The monitor is always put at “Transmit only” mode. In the initialization phase, 9 clock cycles on VCLK pin will be given for the internal synchronization.

During this period, the SDA pin will be kept at high impedance state.

If DDC1 hardware mode is used, the following procedure is recommended to proceed DDC1 operation.

1. Reset DDC1 enable (by default, DDC1 enable is cleared as LOW after Power-on Reset).
2. Set SWENB as high (the default value is zero.)
3. Depending on the data size of EDID data, set EX_DAT as LOW (128 bytes) or HIGH (256 bytes).
4. By using bulky moving commands (DDCADR, RAMBUF involved) to move the entire EDID data to RAM buffer.
5. Reset SWENB to LOW.
6. Reset DDCADR to 00h.
7. Set DDC1 enable as HIGH.

In case SWENB is set as high, interrupt service routine is finished within 133 machine cycle in 40MHz System clock.

The maximum V_{SYNC} (V_{CLK}) frequency is 25Khz (40μs). And the 9th clock of V_{SYNC} (V_{CLK}) is interrupt period.

So the machine cycle be needed is calculated as below. For example,

When 40MHz system clock, 40μs = 133 x (25ns x 12); 133 machine cycle.

12MHz system clock, 40μs = 40 x (83.3ns x 12); 40 machine cycle.

8MHz system clock, 40μs = 26 x (125ns x 12); 26 machine cycle.

Note: If EX_DAT equals to LOW, it is meant the lower part is occupied by DDC1 operation and the upper part is still free to the system. Nevertheless, the effect of the post increment just applies to the part related to DDC1 operation. In other words, the system program is still able to address the locations from 128 to 255 in the RAM buffer through MOVX command but without the facility of the post increment. For example, the case of accessing 200 of the RAM Buffer:

```
MOV R0, #200, and
MOVX A, @R0
```

Figure 42. Transmission Protocol in the DDC1 Interface

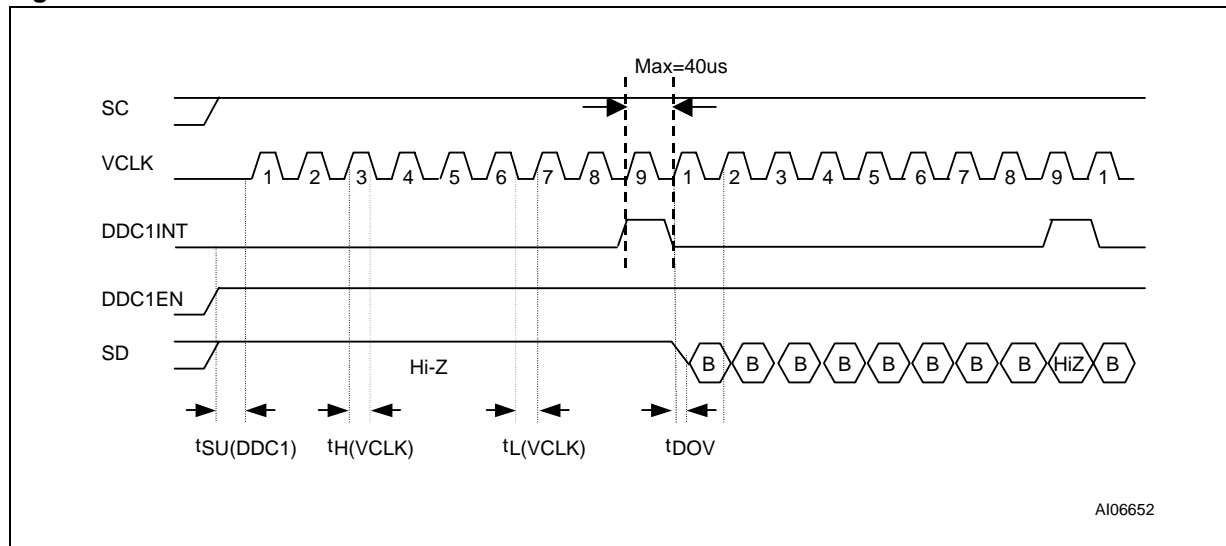

AI06652

DDC2B Protocol

DDC2B is constructed based on the Philips I²C interface. However, in the level of DDC2B, PC host is fixed as the master and the monitor is always regarded as the slave. Both master and slave can be operated as a transmitter or receiver, but the master device determines which mode is activated. In this protocol, address pointer is also used.

According to DDC2B specification, A0 (for WRITE Mode) and A1 (for READ Mode) are assigned as the default address of monitors.

The reception of the incoming data in WRITE Mode or the updating of the outgoing data in READ Mode should be finished within the specified time limit. If software in the slave's side cannot react to the master in time, based on I²C protocol, SCL pin can be stretched low to inhibit the further action from the master. The transaction can be proceeded in either byte or burst format.

Figure 43. Conceptual Structure of the DDC Interface

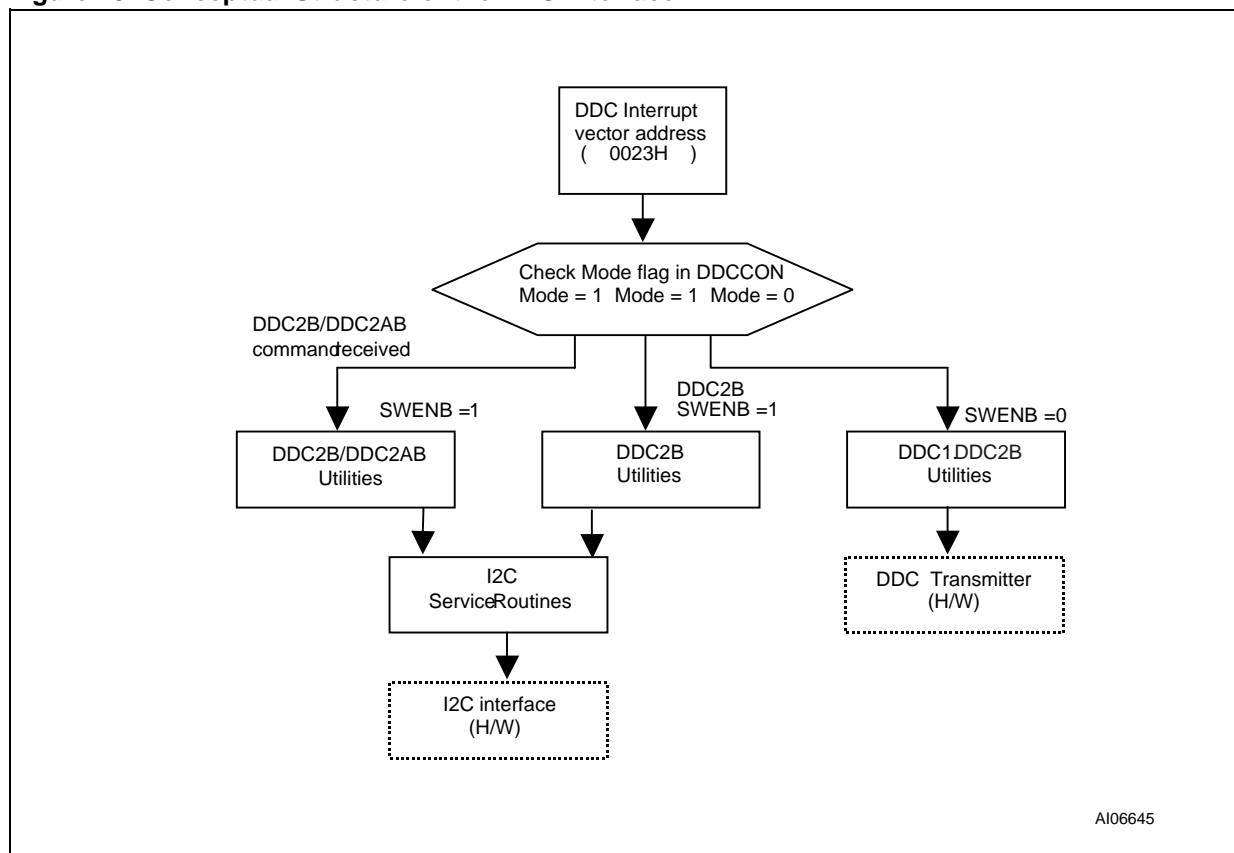

USB HARDWARE

The characteristics of USB hardware are as follows:

- Complies with the Universal Serial Bus specification Rev. 1.1
- Integrated SIE (Serial Interface Engine), FIFO memory and transceiver
- Low speed (1.5Mbit/s) device capability
- Supports control endpoint0 and interrupt endpoint1 and 2
- USB clock input must be 6MHz (requires MCU clock frequency to be 12, 24, or 36MHz).

The analog front-end is an on-chip generic USB transceiver. It is designed to allow voltage levels equal to V_{DD} from the standard logic to interface with the physical layer of the Universal Serial Bus. It is capable of receiving and transmitting serial data at low speed (1.5Mb/s).

The SIE is the digital-front-end of the USB block. This module recovers the 1.5MHz clock, detects the USB sync word and handles all low-level USB protocols and error checking. The bit-clock recov-

ery circuit recovers the clock from the incoming USB data stream and is able to track jitter and frequency drift according to the USB specification. The SIE also translates the electrical USB signals into bytes or signals. Depending upon the device USB address and the USB endpoint.

Address, the USB data is directed to the correct endpoint on SIE interface. The data transfer of this H/W could be of type control or interrupt.

The device's USB address and the enabling of the endpoints are programmable in the SIE configuration header.

USB related registers

The USB block is controlled via seven registers in the memory: (UADR, UCON0, UCON1, UCON2, UISTA, UIEN, and USTA).

Three memory locations on chip which communicate the USB block are:

- USB endpoint0 data transmit register (UDT0)
- USB endpoint0 data receive register (UDR0)
- USB endpoint1 data transmit register (UDT1)

Table 63. USB Address Register (UADR: 0EEh)

7	6	5	4	3	2	1	0
USBEN	UADD6	UADD5	UADD4	UADD3	UADD2	UADD1	UADD0

Table 64. Description of the UADR Bits

Bit	Symbol	R/W	Function
7	USBEN	R/W	USB Function Enable Bit. When USBEN is clear, the USB module will not respond to any tokens from host. RESET clears this bit.
6 to 0	UADD6 to UADD0	R/W	Specify the USB address of the device. RESET clears these bits.

Table 65. USB Interrupt Enable Register (UIEN: 0E9h)

7	6	5	4	3	2	1	0
SUSPNDI	RSTE	RSTFIE	TXD0IE	RXD0IE	TXD1IE	EOPIE	RESUMI

Table 66. Description of the UIEN Bits

Bit	Symbol	R/W	Function
7	SUSPNDI	R/W	Enable SUSPND interrupt
6	RSTE	R/W	Enable USB Reset; also resets the CPU and PSD Modules when bit is set to '1.'
5	RSTFIE	R/W	Enable RSTF (USB Bus Reset Flag) Interrupt
4	TXD0IE	R/W	Enable TXD0 interrupt
3	RXD0IE	R/W	Enable RXD0 interrupt
2	TXD1IE	R/W	Enable TXD1 interrupt
1	EOPIE	R/W	Enable EOP interrupt
0	RESUMI	R/W	Enable USB resume interrupt when it is the Suspend Mode

Table 67. USB Interrupt Status Register (UISTA: 0E8h)

7	6	5	4	3	2	1	0
SUSPND	—	RSTF	TXD0F	RXD0F	TXD1F	EOPF	RESUMF

Table 68. Description of the UISTA Bits

Bit	Symbol	R/W	Function
7	SUSPND	R/W	USB Suspend Mode Flag. To save power, this bit should be set if a 3ms constant idle state is detected on USB bus. Setting this bit stops the clock to the USB and causes the USB module to enter Suspend Mode. Software must clear this bit after the Resume flag (RESUMF) is set while this Resume interrupt flag is serviced
6	—	—	Reserved
5	RSTF	R	USB Reset Flag. This bit is set when a valid $\overline{\text{RESET}}$ signal state is detected on the D+ and D- lines. When the RSTE bit in the UIEN Register is set, this reset detection will also generate an internal reset signal to reset the CPU and other peripherals including the USB module.
4	TXD0F	R/W	Endpoint0 Data Transmit Flag. This bit is set after the data stored in Endpoint 0 transmit buffers has been sent and an ACK handshake packet from the host is received. Once the next set of data is ready in the transmit buffers, software must clear this flag. To enable the next data packet transmission, TX0E must also be set. If TXD0F Bit is not cleared, a NAK handshake will be returned in the next IN transactions. $\overline{\text{RESET}}$ clears this bit.
3	RXD0F	R/W	Endpoint0 Data Receive Flag. This bit is set after the USB module has received a data packet and responded with ACK handshake packet. Software must clear this flag after all of the received data has been read. Software must also set RX0E Bit to one to enable the next data packet reception. If RXD0F Bit is not cleared, a NAK handshake will be returned in the next OUT transaction. $\overline{\text{RESET}}$ clears this bit.
2	TXD1F	R/W	Endpoint1 / Endpoint2 Data Transmit Flag. This bit is shared by Endpoints 1 and Endpoints 2. It is set after the data stored in the shared Endpoint 1/ Endpoint 2 transmit buffer has been sent and an ACK handshake packet from the host is received. Once the next set of data is ready in the transmit buffers, software must clear this flag. To enable the next data packet transmission, TX1E must also be set. If TXD1F Bit is not cleared, a NAK handshake will be returned in the next IN transaction. $\overline{\text{RESET}}$ clears this bit.
1	EOPF	R/W	End of Packet Flag. This bit is set when a valid End of Packet sequence is detected on the D+ and D-line. Software must clear this flag. $\overline{\text{RESET}}$ clears this bit.
0	RESUMF	R/W	Resume Flag. This bit is set when USB bus activity is detected while the SUSPND Bit is set. Software must clear this flag. $\overline{\text{RESET}}$ clears this bit.

Table 69. USB Endpoint0 Transmit Control Register (UCON0: 0EAh)

7	6	5	4	3	2	1	0
TSEQ0	STALL0	TX0E	RX0E	TP0SIZ3	TP0SIZ2	TP0SIZ1	TP0SIZ0

Table 70. Description of the UCON0 Bits

Bit	Symbol	R/W	Function
7	TSEQ0	R/W	Endpoint0 Data Sequence Bit. (0=DATA0, 1=DATA1) This bit determines which type of data packet (DATA0 or DATA1) will be sent during the next IN transaction. Toggling of this bit must be controlled by software. $\overline{\text{RESET}}$ clears this bit
6	STALL0	R/W	Endpoint0 Force Stall Bit. This bit causes Endpoint 0 to return a STALL handshake when polled by either an IN or OUT token by the USB Host Controller. The USB hardware clears this bit when a SETUP token is received. $\overline{\text{RESET}}$ clears this bit.
5	TX0E	R/W	Endpoint0 Transmit Enable. This bit enables a transmit to occur when the USB Host Controller sends an IN token to Endpoint 0. Software should set this bit when data is ready to be transmitted. It must be cleared by software when no more Endpoint 0 data needs to be transmitted. If this bit is '0' or the TXD0F is set, the USB will respond with a NAK handshake to any Endpoint 0 IN tokens. $\overline{\text{RESET}}$ clears this bit.
4	RX0E	R/W	Endpoint0 receive enable. This bit enables a receive to occur when the USB Host Controller sends an OUT token to Endpoint 0. Software should set this bit when data is ready to be received. It must be cleared by software when data cannot be received. If this bit is '0' or the RXD0F is set, the USB will respond with a NAK handshake to any Endpoint 0 OUT tokens. $\overline{\text{RESET}}$ clears this bit.
3 to 0	TP0SIZ3 to TP0SIZ0	R/W	The number of transmit data bytes. These bits are cleared by $\overline{\text{RESET}}$.

Table 71. USB Endpoint1 (and 2) Transmit Control Register (UCON1: 0EBh)

7	6	5	4	3	2	1	0
TSEQ1	EP12SEL	TX1E	FRESUM	TP1SIZ3	TP1SIZ2	TP1SIZ1	TP1SIZ0

Table 72. Description of the UCON1 Bits

Bit	Symbol	R/W	Function
7	TSEQ1	R/W	Endpoint 1/ Endpoint 2 Transmit Data Packet PID. (0=DATA0, 1=DATA1) This bit determines which type of data packet (DATA0 or DATA1) will be sent during the next IN transaction directed to Endpoint 1 or Endpoint 2. Toggling of this bit must be controlled by software. <u>RESET</u> clears this bit.
6	EP12SEL	R/W	Endpoint 1/ Endpoint 2 Transmit Selection. (0=Endpoint 1, 1=Endpoint 2) This bit specifies whether the data inside the registers UDT1 are used for Endpoint 1 or Endpoint 2. If all the conditions for a successful Endpoint 2 USB response to a hosts IN token are satisfied (TXD1F=0, TX1E=1, STALL2=0, and EP2E=1) except that the EP12SEL Bit is configured for Endpoint 1, the USB responds with a NAK handshake packet. <u>RESET</u> clears this bit.
5	TX1E	R/W	Endpoint1 / Endpoint2 Transmit Enable. This bit enables a transmit to occur when the USB Host Controller send an IN token to Endpoint 1 or Endpoint 2. The appropriate endpoint enable bit, EP1E or EP2E Bit in the UCON2 register, should also be set. Software should set the TX1E Bit when data is ready to be transmitted. It must be cleared by software when no more data needs to be transmitted. If this bit is '0' or TXD1F is set, the USB will respond with a NAK handshake to any Endpoint 1 or Endpoint 2 directed IN token. <u>RESET</u> clears this bit.
4	FRESUM	R/W	Force Resume. This bit forces a resume state ("K" on non-idle state) on the USB data lines to initiate a remote wake-up. Software should control the timing of the forced resume to be between 10ms and 15ms. Setting this bit will not cause the RESUMF Bit to set.
3 to 0	TP1SIZ3 to TP1SIZ0	R/W	The number of transmit data bytes. These bits are cleared by <u>RESET</u> .

Table 73. USB Control Register (UCON2: 0ECh)

7	6	5	4	3	2	1	0
—	—	—	SOUT	EP2E	EP1E	STALL2	STALL1

Table 74. Description of the UCON2 Bits

Bit	Symbol	R/W	Function
7 to 5	—	—	Reserved
4	SOUT	R/W	Status out is used to automatically respond to the OUT of a control READ transfer
3	EP2E	R/W	Endpoint2 enable. $\overline{\text{RESET}}$ clears this bit
2	EP1E	R/W	Endpoint1 enable. $\overline{\text{RESET}}$ clears this bit
1	STALL2	R/W	Endpoint2 Force Stall Bit. $\overline{\text{RESET}}$ clears this bit
0	STALL1	R/W	Endpoint1 Force Stall Bit. $\overline{\text{RESET}}$ clears this bit

Table 75. USB Endpoint0 Status Register (USTA: 0EDh)

7	6	5	4	3	2	1	0
RSEQ	SETUP	IN	OUT	RP0SIZ3	RP0SIZ2	RP0SIZ1	RP0SIZ0

Table 76. Description of the USTA Bits

Bit	Symbol	R/W	Function
7	RSEQ	R/W	Endpoint0 receive data packet PID. (0=DATA0, 1=DATA1) This bit will be compared with the type of data packet last received for Endpoint0
6	SETUP	R	SETUP Token Detect Bit. This bit is set when the received token packet is a SEPUP token, PID = b1101.
5	IN	R	IN Token Detect Bit. This bit is set when the received token packet is an IN token.
4	OUT	R	OUT Token Detect Bit. This bit is set when the received token packet is an OUT token.
3 to 0	RP0SIZ3 to RP0SIZ0	R	The number of data bytes received in a DATA packet

Table 77. USB Endpoint0 Data Receive Register (UDR0: 0EFh)

7	6	5	4	3	2	1	0
UDR0.7	UDR0.6	UDR0.5	UDR0.4	UDR0.3	UDR0.2	UDR0.1	UDR0.0

Table 78. USB Endpoint0 Data Transmit Register (UDT0: 0E7h)

7	6	5	4	3	2	1	0
UDT0.7	UDT0.6	UDT0.5	UDT0.4	UDT0.3	UDT0.2	UDT0.1	UDT0.0

Table 79. USB Endpoint1 Data Transmit Register (UDT1: 0E6h)

7	6	5	4	3	2	1	0
UDT1.7	UDT1.6	UDT1.5	UDT1.4	UDT1.3	UDT1.2	UDT1.1	UDT1.0

μPSD325X DEVICES

The USCL 8-bit Prescaler Register for USB is at E1h. The USCL should be loaded with a value that results in a clock rate of 6MHz for the USB using the following formula:

$$\text{USB clock input} = (F_{\text{osc}} / 2) / (\text{Prescaler register value} + 1)$$

Where F_{osc} is the MCU clock input frequency.

Note: USB works ONLY with the MCU Clock frequencies of 12, 24, or 36MHz. The Prescaler values for these frequencies are 0, 1, and 2.

Table 80. USB SFR Memory Map

SFR Addr	Reg Name	Bit Register Name								Reset Value	Comments
		7	6	5	4	3	2	1	0		
E1	USCL									00	8-bit Prescaler for USB logic
E6	UDT1	UDT1.7	UDT1.6	UDT1.5	UDT1.4	UDT1.3	UDT1.2	UDT1.1	UDT1.0	00	USB Endpt1 Data Xmit
E7	UDT0	UDT0.7	UDT0.6	UDT0.5	UDT0.4	UDT0.3	UDT0.2	UDT0.1	UDT0.0	00	USB Endpt0 Data Xmit
E8	UISTA	SUSPND	—	RSTF	TXD0F	RXD0F	RXD1F	EOPF	RESUMF	00	USB Interrupt Status
E9	UIEN	SUSPNDIE	RSTE	RSTFIE	TXD0IE	RXD0IE	TXD1IE	EOPIE	RESUMIE	00	USB Interrupt Enable
EA	UCON0	TSEQ0	STALL0	TX0E	RX0E	TP0SIZ3	TP0SIZ2	TP0SIZ1	TP0SIZ0	00	USB Endpt0 Xmit Control
EB	UCON1	TSEQ1	EP12SEL	—	FRESUM	TP1SIZ3	TP1SIZ2	TP1SIZ1	TP1SIZ0	00	USB Endpt1 Xmit Control
EC	UCON2	—	—	—	SOUT	EP2E	EP1E	STALL2	STALL1	00	USB Control Register
ED	USTA	RSEQ	SETUP	IN	OUT	RP0SIZ3	RP0SIZ2	RP0SIZ1	RP0SIZ0	00	USB Endpt0 Status
EE	UADR	USBEN	UADD6	UADD5	UADD4	UADD3	UADD2	UADD1	UADD0	00	USB Address Register
EF	UDR0	UDR0.7	UDR0.6	UDR0.5	UDR0.4	UDR0.3	UDR0.2	UDR0.1	UDR0.0	00	USB Endpt0 Data Recv

Transceiver

USB Physical Layer Characteristics. The following section describes the μPSD325X devices compliance to the Chapter 7 Electrical section of the USB Specification, Revision 1.1. The section contains all signaling, and physical layer specifications necessary to describe a low speed USB function.

Low Speed Driver Characteristics. The μPSD325X devices use a differential output driver to drive the Low Speed USB data signal onto the USB cable. The output swings between the differential high and low state are well balanced to minimize signal skew. The slew rate control on the driver minimizes the radiated noise and cross talk on the USB cable. The driver's outputs support three-state operation to achieve bi-directional half duplex operation. The μPSD325X devices driver

tolerates a voltage on the signal pins of -0.5V to 3.6V with respect to local ground reference without damage. The driver tolerates this voltage for 10.0μs while the driver is active and driving, and tolerates this condition indefinitely when the driver is in its high impedance state.

A low speed USB connection is made through an unshielded, untwisted wire cable a maximum of 3 meters in length. The rise and fall time of the signals on this cable are well controlled to reduce RFI emissions while limiting delays, signaling skews and distortions. The μPSD325X devices driver reaches the specified static signal levels with smooth rise and fall times, resulting in segments between low speed devices and the ports to which they are connected.

Figure 44. Low Speed Driver Signal Waveforms

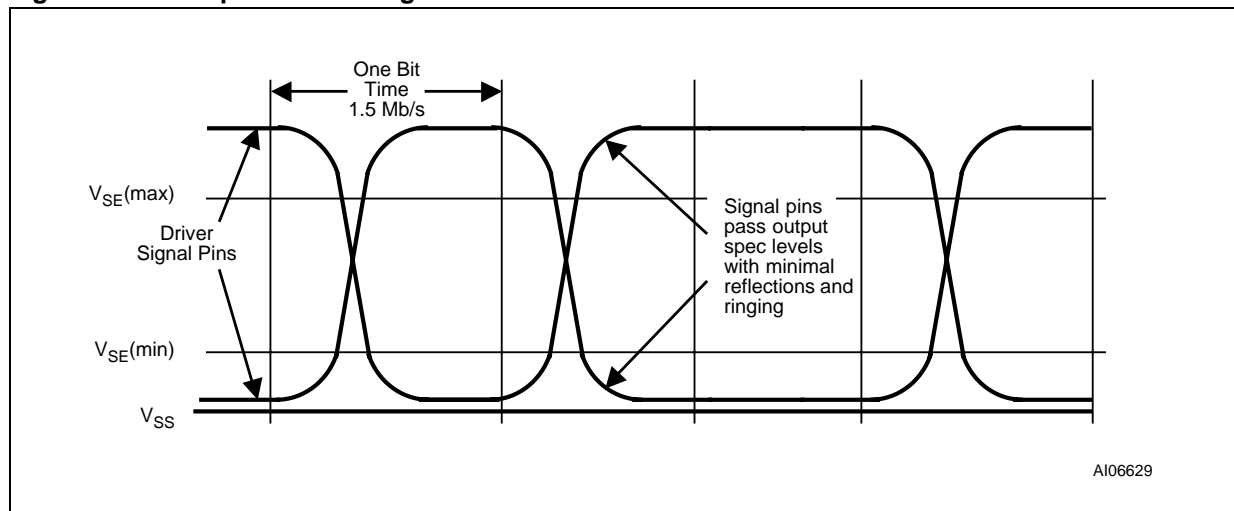

Receiver Characteristics

The μPSD325X devices has a differential input receiver which is able to accept the USB data signal. The receiver features an input sensitivity of at least 200mV when both differential data inputs are in the range of at least 0.8V to 2.5V with respect to its local ground reference. This is the common mode range, as shown in Figure 45. The receiver

tolerates static input voltages between -0.5V to 3.8V with respect to its local ground reference without damage. In addition to the differential receiver, there is a single-ended receiver for each of the two data lines. The single-ended receivers have a switching threshold between 0.8V and 2.0V (TTL inputs).

Figure 45. Differential Input Sensitivity Over Entire Common Mode Range

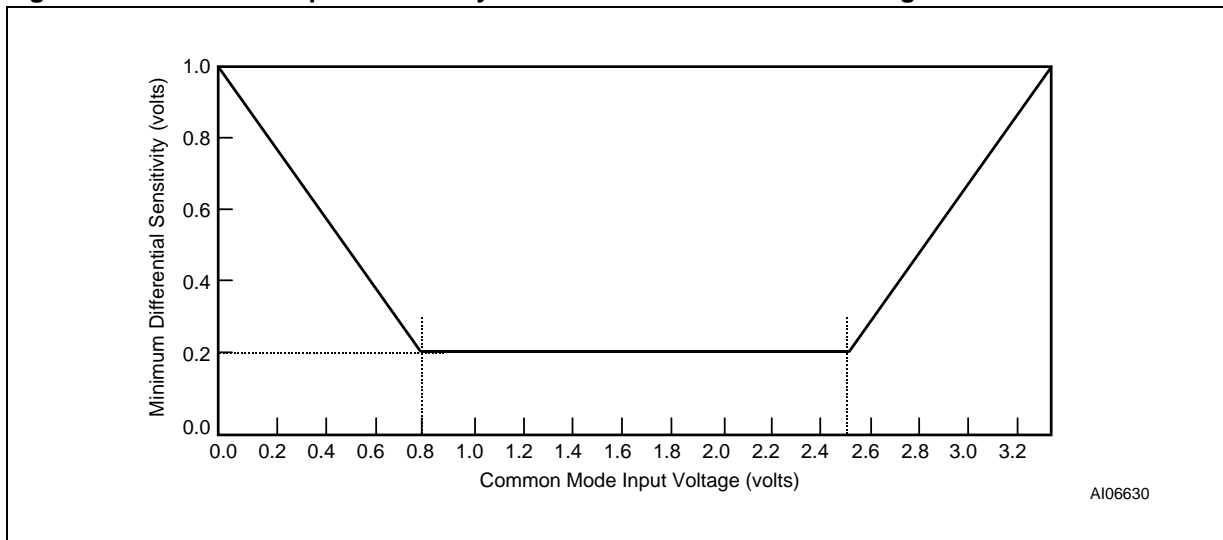

External USB Pull-Up Resistor

The USB system specifies a pull-up resistor on the D- pin for low-speed peripherals. The USB Spec 1.1 describes a 1.5kΩ pull-up resistor to a 3.3V supply. An approved alternative method is a 7.5kΩ pull-up to the USB V_{CC} supply. This alterna-

tive is defined for low-speed devices with an integrated cable. The chip is specified for the 7.5kΩ pull-up. This eliminates the need for an external 3.3V regulator, or for a pin dedicated to providing a 3.3V output from the chip.

Figure 46. USB Data Signal Timing and Voltage Levels

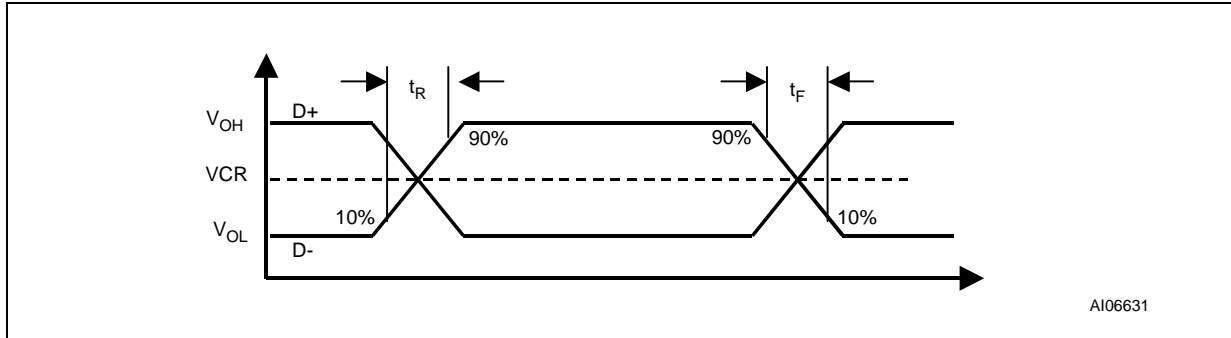

AI06631

Figure 47. Receiver Jitter Tolerance

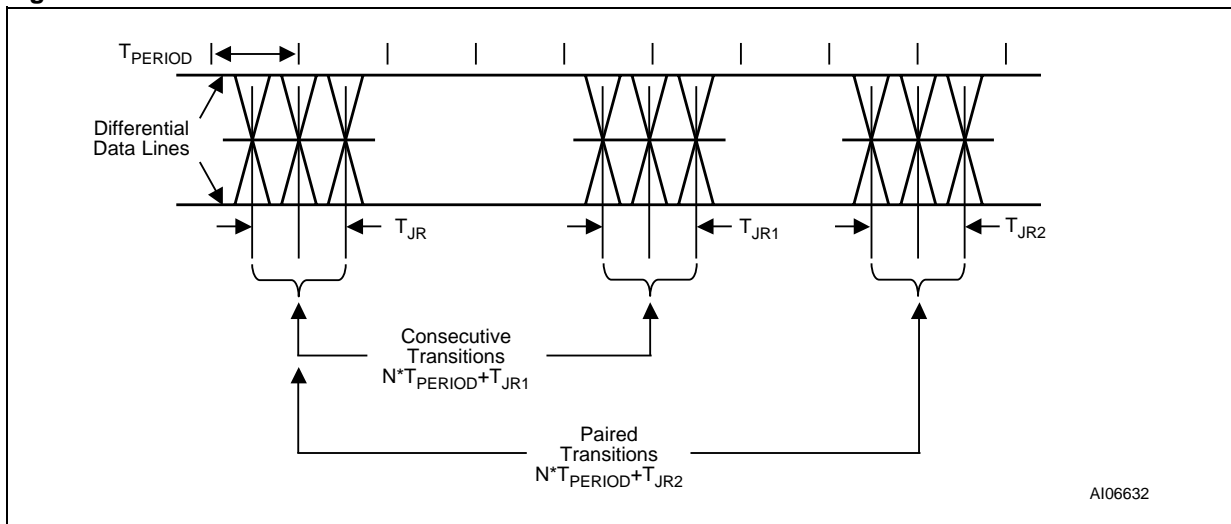

AI06632

Figure 48. Differential to EOP Transition Skew and EOP Width

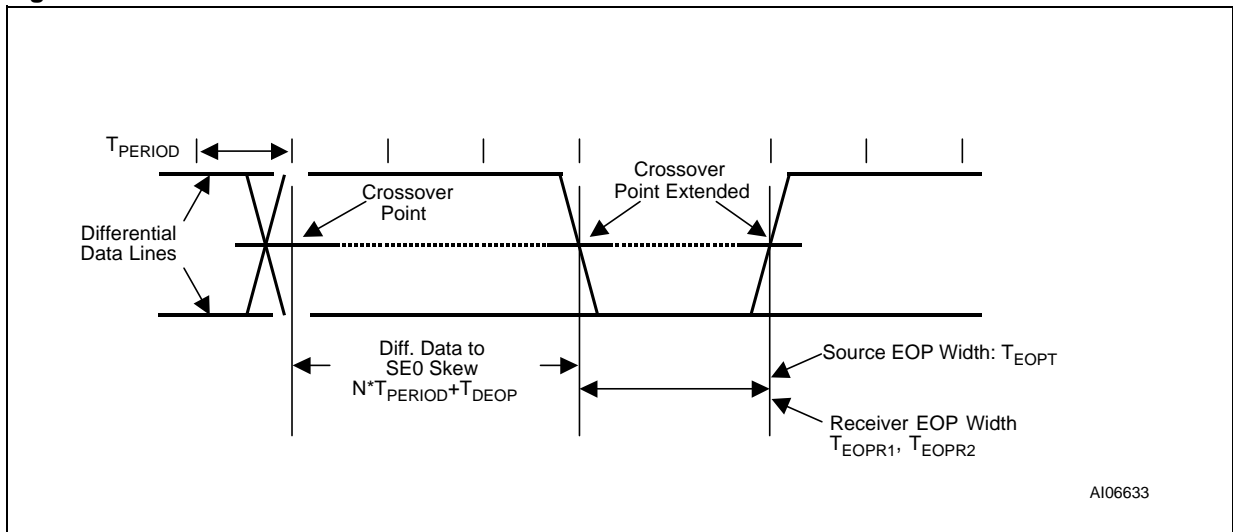

Figure 49. Differential Data Jitter

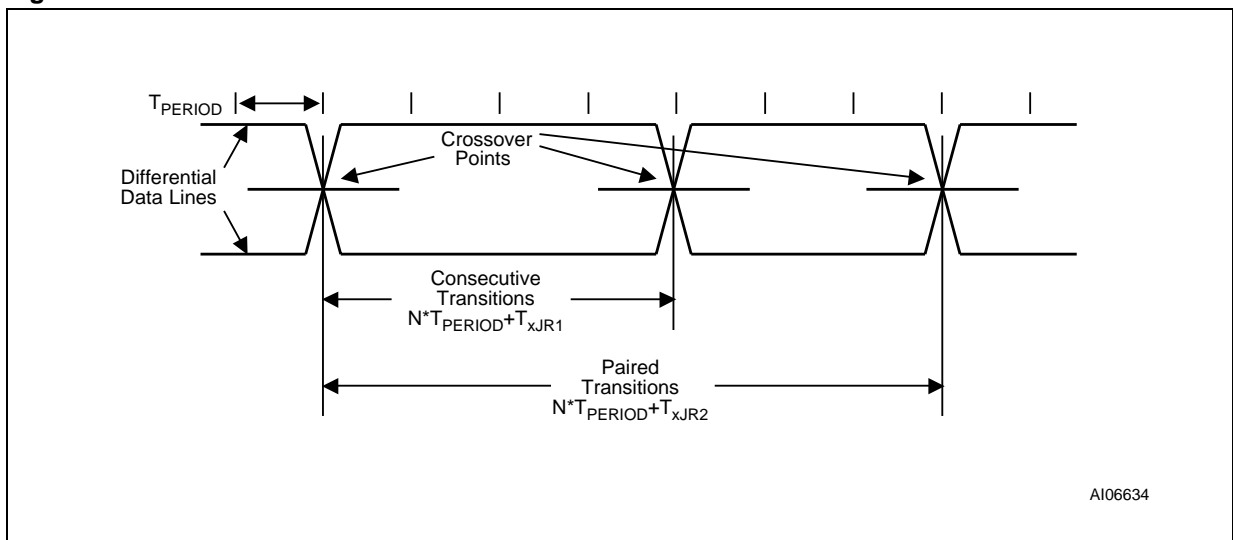

Table 81. Transceiver DC Characteristics

Symb	Parameter	Test Conditions	Min	Max	Unit
V _{OH}	Static Output High	15kΩ±5%	2.8	3.6	V
V _{OL}	Static Output Low	Notes 2,3	—	0.3	V
V _{DI}	Differential Input Sensitivity	(D+) - (D-) , Fig 6.9	0.2	—	V
V _{CM}	Differential Input Common Mode	Fig 6.9	0.8	2.5	V
V _{SE}	Single Ended Receiver Threshold	—	0.8	2.0	V
C _{IN}	Transceiver Capacitance	—	—	20	pF
I _{IO}	Data Line (D+, D-) Leakage	0V<(D+,D-)<3. 3,	-10	10	μA
R _{PU}	External Bus Pull-up Resistance, D-	7.5kΩ±2%	7.35	7.65	kΩ
R _{PD}	External Bus Pull-down Resistance	15kΩ±5%	14.25	15.75	kΩ

Note: 1. V_{DD}=5V ± 10%; V_{SS}=0V; T_A=0 to 70
 2. Level guaranteed for range of V_{DD} = 4.5V to 5.5V
 3. With RPU, external idle resistor, 7.5k±2%, D- to V_{DD}.
 4. C_L of 50pF(75ns) to 350pF (300ns).
 5. Measured at crossover point of differential data signals.
 6. USB specification indicates 330ns

Table 82. Transceiver AC Characteristics

Parameter	Symb	Min	Max	Unit	Test Conditions
Low Speed Data Rate	fDRATE	1.4775	1.5225	Mbit/s	Ave. bit rate
Receiver Data Jitter Tolerance	tDJR1	-75	75	ns	to next transition,
Differential Input Sensitivity	tDJR2	-45	45	ns	for paired transition,
Differential to EOP Transition Skew	tDEOP	-40	100	ns	Fig 6.10 ⁴
EOP Width at Receiver	tEOPR1	165	—	ns	rejects as EOP ^{4, 5}
EOP Width at Receiver	tEOPR2	675	—	ns	accepts as EOP ⁴
Source EOP Width	tEOPT	-1.25	1.50	μs	—
Differential Driver Jitter	tUDJ1	-95	95	ns	to next transition,
Differential Driver Jitter	tUDJ2	-150	150	ns	to paired transition,
USB Data Transition Rise Time	tR	75	300	ns	Notes ^{1, 2, 3}
USB Data Transition Fall Time	tF	75	300	ns	Notes ^{1, 2, 3}
Rise/Fall Time Matching	tRFM	80	120	%	t _R / t _F
Output Signal Crossover Volt age	VCRS	1.3	2.0	V	—

Note: 1. V_{DD}=5V ± 10%; V_{SS}=0V; T_A=0 to 70

PSD MODULE

- The PSD Module provides configurable Program and Data memories to the 8032 CPU core (MCU). In addition, it has its own set of I/O ports and a PLD with 16 macrocells for general logic implementation.
- Ports A,B,C, and D are general purpose programmable I/O ports that have a port architecture which is different from the I/O ports in the MCU Module.
- The PSD Module communicates with the MCU Module through the internal address, data bus (AO-A15, DO-D7) and control signals (RD, WR, PSEN, ALE, RESET). The user defines the Decoding PLD in the PSDsoft Development Tool and can map the resources in the PSD Module to any program or data address space. Figure 50 shows the functional blocks in the PSD Module.

Functional Overview

- 1 or 2 Mbit Flash memory. This is the main Flash memory. It is divided into eight equal-sized blocks that can be accessed with user-specified addresses.
 - Secondary 256 Kbit Flash boot memory. It is divided into four equal-sized blocks that can be accessed with user-specified addresses. This secondary memory brings the ability to execute code and update the main Flash *concurrently*.
 - 256 Kbit SRAM. The SRAM's contents can be protected from a power failure by connecting an external battery.
 - CPLD with 1G Output Micro Cells (OMCs) and 24 Input Micro Cells (IMCs). The CPLD may be used to efficiently implement a variety of logic functions for internal and external control.
- Examples include state machines, loadable shift registers, and loadable counters.
- Decode PLD (DPLD) that decodes address for selection of memory blocks in the PSD Module.
 - Configurable I/O ports (Port A,B,C and D) that can be used for the following functions:
 - MCU I/Os
 - PLD I/Os
 - Latched MCU address output
 - Special function I/Os.
 - I/O ports may be configured as open-drain outputs.
 - Built-in JTAG compliant serial port allows full-chip In-System Programmability (ISP). With it, you can program a blank device or reprogram a device in the factory or the field.
 - Internal page register that can be used to expand the 8032 MCU Module address space by a factor of 256.
 - Internal programmable Power Management Unit (PMU) that supports a low-power mode called Power-down Mode. The PMU can automatically detect a lack of the 8032 CPU core activity and put the PSD Module into Power-down Mode.
 - Erase/WRITE cycles:
 - Flash memory - 100,000 minimum
 - PLD - 1,000 minimum
 - Data Retention: 15 year minimum (for Main Flash memory, Boot, PLD and Configuration bits)

Figure 50. PSD MODULE Block Diagram

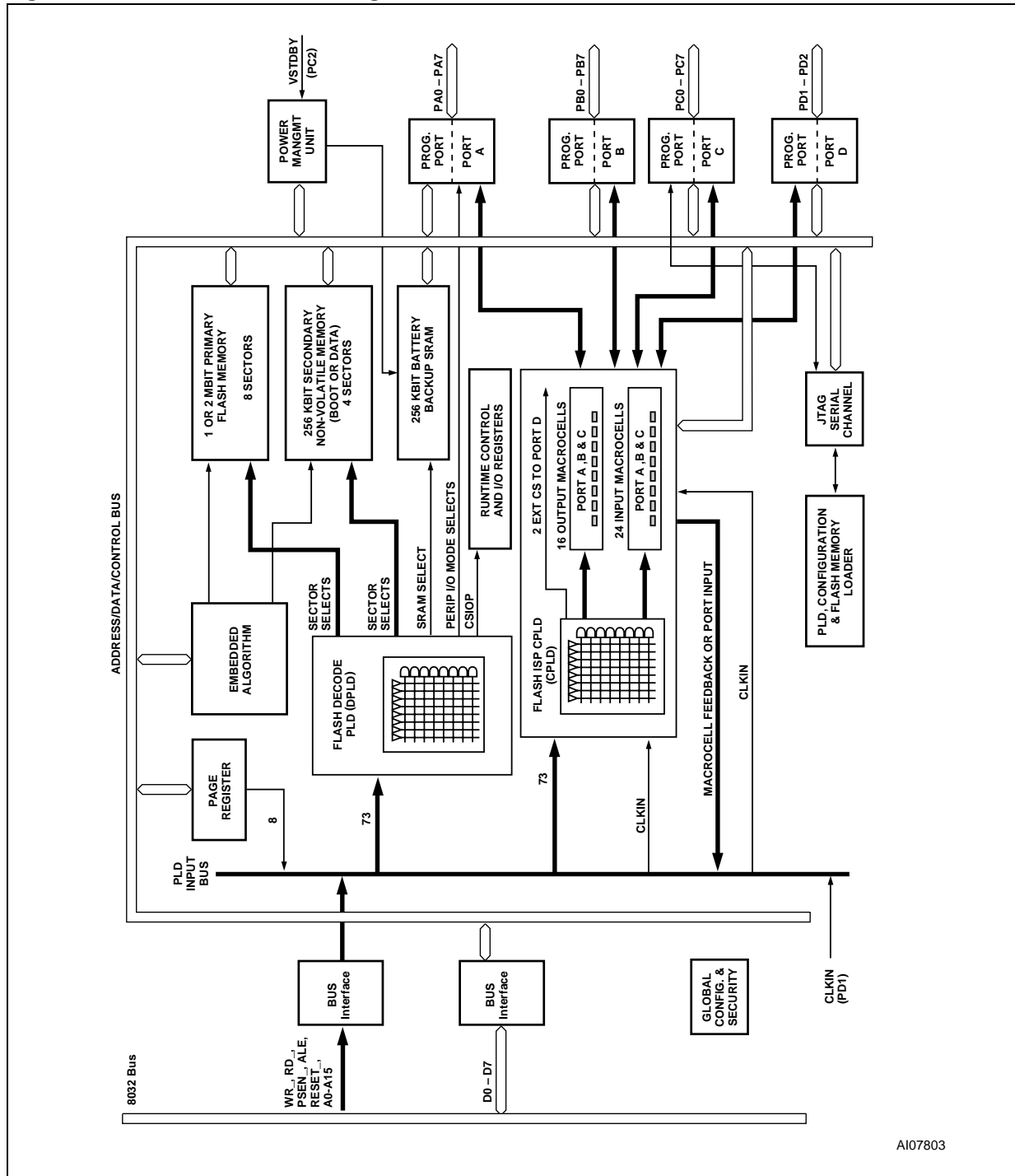

AI07803

μPSD325X DEVICES

In-System Programming (ISP)

Using the JTAG signals on Port C, the entire PSD MODULE device can be programmed or erased without the use of the MCU. The primary Flash memory can also be programmed in-system by the MCU executing the programming algorithms out of the secondary memory, or SRAM. The secondary memory can be programmed the same

way by executing out of the primary Flash memory. The PLD or other PSD MODULE Configuration blocks can be programmed through the JTAG port or a device programmer. Table 83 indicates which programming methods can program different functional blocks of the PSD MODULE.

Table 83. Methods of Programming Different Functional Blocks of the PSD MODULE

Functional Block	JTAG Programming	Device Programmer	IAP
Primary Flash Memory	Yes	Yes	Yes
Secondary Flash Memory	Yes	Yes	Yes
PLD Array (DPLD and CPLD)	Yes	Yes	No
PSD MODULE Configuration	Yes	Yes	No

DEVELOPMENT SYSTEM

The μPSD325X devices are supported by PSDsoft, a Windows-based software development tool (Windows-95, Windows-98, Windows-NT). A PSD MODULE design is quickly and easily produced in a point and click environment. The designer does not need to enter Hardware Description Language (HDL) equations, unless desired, to define PSD MODULE pin functions and memory map information. The general design flow is shown in Figure 51. PSDsoft is available from our web site (the ad-

dress is given on the back page of this data sheet) or other distribution channels.

PSDsoft directly supports a low cost device programmer from ST: FlashLINK (JTAG). The programmer may be purchased through your local distributor/representative, or directly from our web site using a credit card. The μPSD325X devices are also supported by third party device programmers. See our web site for the current list.

Figure 51. PSDsoft Express Development Tool

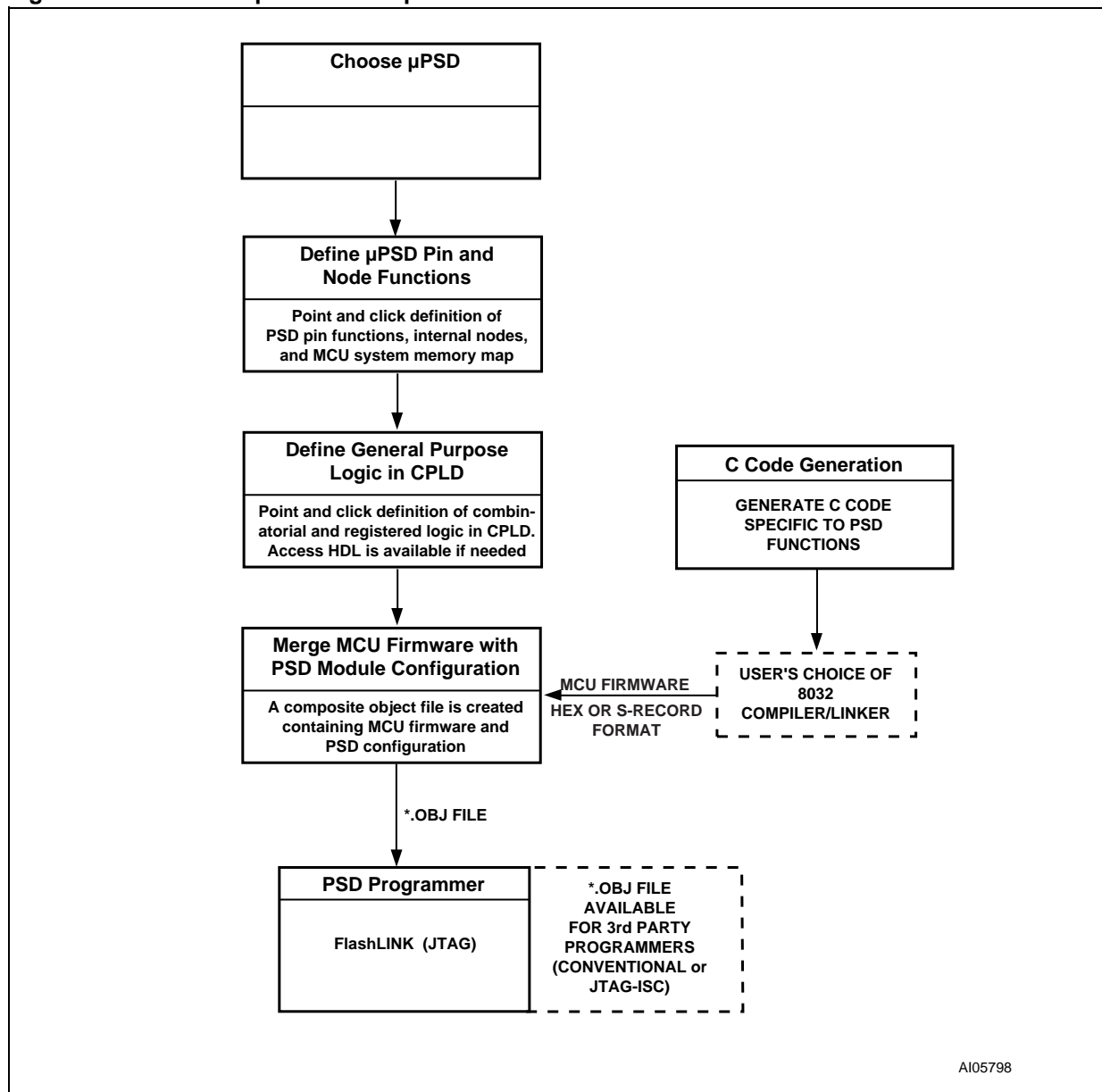

AI05798

PSD MODULE REGISTER DESCRIPTION AND ADDRESS OFFSET

Table 84 shows the offset addresses to the PSD MODULE registers relative to the CSIOP base address. The CSIOP space is the 256 bytes of address that is allocated by the user to the internal

PSD MODULE registers. Table 84 provides brief descriptions of the registers in CSIOP space. The following section gives a more detailed description.

Table 84. Register Address Offset

Register Name	Port A	Port B	Port C	Port D	Other ¹	Description
Data In	00	01	10	11		Reads Port pin as input, MCU I/O Input Mode
Control	02	03				Selects mode between MCU I/O or Address Out
Data Out	04	05	12	13		Stores data for output to Port pins, MCU I/O Output Mode
Direction	06	07	14	15		Configures Port pin as input or output
Drive Select	08	09	16	17		Configures Port pins as either CMOS or Open Drain on some pins, while selecting high slew rate on other pins.
Input Macrocell	0A	0B	18			Reads Input Macrocells
Enable Out	0C	0D	1A	1B		Reads the status of the output enable to the I/O Port driver
Output Macrocells AB	20	20				READ – reads output of macrocells AB WRITE – loads macrocell flip-flops
Output Macrocells BC		21	21			READ – reads output of macrocells BC WRITE – loads macrocell flip-flops
Mask Macrocells AB	22	22				Blocks writing to the Output Macrocells AB
Mask Macrocells BC		23	23			Blocks writing to the Output Macrocells BC
Primary Flash Protection					C0	Read-only – Primary Flash Sector Protection
Secondary Flash memory Protection					C2	Read-only – PSD MODULE Security and Secondary Flash memory Sector Protection
PMMR0					B0	Power Management Register 0
PMMR2					B4	Power Management Register 2
Page					E0	Page Register
VM					E2	Places PSD MODULE memory areas in Program and/or Data space on an individual basis.

Note: 1. Other registers that are not part of the I/O ports.

PSD MODULE DETAILED OPERATION

As shown in Figure 15, the PSD MODULE consists of five major types of functional blocks:

- Memory Block
- PLD Blocks
- I/O Ports
- Power Management Unit (PMU)
- JTAG Interface

The functions of each block are described in the following sections. Many of the blocks perform multiple functions, and are user configurable.

MEMORY BLOCKS

The PSD MODULE has the following memory blocks:

- Primary Flash memory
- Secondary Flash memory
- SRAM

The Memory Select signals for these blocks originate from the Decode PLD (DPLD) and are user-defined in PSDsoft Express.

Primary Flash Memory and Secondary Flash memory Description

The primary Flash memory is divided evenly into eight equal sectors. The secondary Flash memory is divided into four equal sectors. Each sector of either memory block can be separately protected from Program and Erase cycles.

Flash memory may be erased on a sector-by-sector basis. Flash sector erasure may be suspended while data is read from other sectors of the block and then resumed after reading.

During a Program or Erase cycle in Flash memory, the status can be output on Ready/Busy (PC3). This pin is set up using PSDsoft Express Configuration.

Memory Block Select Signals

The DPLD generates the Select signals for all the internal memory blocks (see the section entitled

“PLDs,” page 120). Each of the eight sectors of the primary Flash memory has a Select signal (FS0-FS7) which can contain up to three product terms. Each of the four sectors of the secondary Flash memory has a Select signal (CSBOOT0-CSBOOT3) which can contain up to three product terms. Having three product terms for each Select signal allows a given sector to be mapped in Program or Data space.

Ready/Busy (PC3). This signal can be used to output the Ready/Busy status of the Flash memory. The output on Ready/Busy (PC3) is a '0' (Busy) when Flash memory is being written to, or when Flash memory is being erased. The output is a 1 (Ready) when no WRITE or Erase cycle is in progress.

Memory Operation. The primary Flash memory and secondary Flash memory are addressed through the MCU Bus. The MCU can access these memories in one of two ways:

- The MCU can execute a typical bus WRITE or READ operation.
- The MCU can execute a specific Flash memory instruction that consists of several WRITE and READ operations. This involves writing specific data patterns to special addresses within the Flash memory to invoke an embedded algorithm. These instructions are summarized in Table 85.

Typically, the MCU can read Flash memory using READ operations, just as it would read a ROM device. However, Flash memory can only be altered using specific Erase and Program instructions. For example, the MCU cannot write a single byte directly to Flash memory as it would write a byte to RAM. To program a byte into Flash memory, the MCU must execute a Program instruction, then test the status of the Program cycle. This status test is achieved by a READ operation or polling Ready/Busy (PC3).

Flash memory can also be read by using special instructions to retrieve particular Flash device information (sector protect status and ID).

Instructions

An instruction consists of a sequence of specific operations. Each received byte is sequentially decoded by the PSD MODULE and not executed as a standard WRITE operation. The instruction is executed when the correct number of bytes are properly received and the time between two consecutive bytes is shorter than the time-out period. Some instructions are structured to include READ operations after the initial WRITE operations.

The instruction must be followed exactly. Any invalid combination of instruction bytes or time-out between two consecutive bytes while addressing Flash memory resets the device logic into READ Mode (Flash memory is read like a ROM device).

The Flash memory supports the instructions summarized in Table 85:

Flash memory:

- Erase memory by chip or sector
- Suspend or resume sector erase
- Program a Byte
- RESET to READ Mode

- Read primary Flash Identifier value
- Read Sector Protection Status
- Bypass

These instructions are detailed in Table 85. For efficient decoding of the instructions, the first two bytes of an instruction are the coded cycles and are followed by an instruction byte or confirmation byte. The coded cycles consist of writing the data AAh to address X555h during the first cycle and data 55h to address XAAAh during the second cycle. Address signals A15-A12 are Don't Care during the instruction WRITE cycles. However, the appropriate Sector Select (FS0-FS7 or CSBOOT0-CSBOOT3) must be selected.

The primary and secondary Flash memories have the same instruction set (except for Read Primary Flash Identifier). The Sector Select signals determine which Flash memory is to receive and execute the instruction. The primary Flash memory is selected if any one of Sector Select (FS0-FS7) is High, and the secondary Flash memory is selected if any one of Sector Select (CSBOOT0-CSBOOT3) is High.

Table 85. Instructions

Instruction	FS0-FS7 or CSBOOT0-CSBOOT3	Cycle 1	Cycle 2	Cycle 3	Cycle 4	Cycle 5	Cycle 6	Cycle 7
READ ⁵	1	"Read" RD @ RA						
READ Main Flash ID ⁶	1	AAh@ X555h	55h@ XAAAh	90h@ X555h	Read ID @ XX01h			
READ Sector Protection ^{6,8,13}	1	AAh@ X555h	55h@ XAAAh	90h@ X555h	Read status @ XX02h			
Program a Flash Byte ¹³	1	AAh@ X555h	55h@ XAAAh	A0h@ X555h	PD@ PA			
Flash Sector Erase ^{7,13}	1	AAh@ X555h	55h@ XAAAh	80h@ X555h	AAh@ X555h	55h@ XAAAh	30h@ SA	30h ⁷ @ next SA
Flash Bulk Erase ¹³	1	AAh@ X555h	55h@ XAAAh	80h@ X555h	AAh@ X555h	55h@ XAAAh	10h@ X555h	
Suspend Sector Erase ¹¹	1	B0h@ XXXXh						
Resume Sector Erase ¹²	1	30h@ XXXXh						
RESET ⁶	1	F0h@ XXXXh						
Unlock Bypass	1	AAh@ X555h	55h@ XAAAh	20h@ X555h				
Unlock Bypass Program ⁹	1	A0h@ XXXXh	PD@ PA					
Unlock Bypass Reset ¹⁰	1	90h@ XXXXh	00h@ XXXXh					

- Note: 1. All bus cycles are WRITE bus cycles, except the ones with the "Read" label
 2. All values are in hexadecimal:
 X = Don't care. Addresses of the form XXXXh, in this table, must be even addresses
 RA = Address of the memory location to be read
 RD = Data READ from location RA during the READ cycle
 PA = Address of the memory location to be programmed. Addresses are latched on the falling edge of WRITE Strobe (\overline{WR} , CNTL0).
 PA is an even address for PSD in Word Programming Mode.
 PD = Data word to be programmed at location PA. Data is latched on the rising edge of WRITE Strobe (\overline{WR} , CNTL0)
 SA = Address of the sector to be erased or verified. The Sector Select (FS0-FS7 or CSBOOT0-CSBOOT3) of the sector to be erased, or verified, must be Active (High).
 3. Sector Select (FS0-FS7 or CSBOOT0-CSBOOT3) signals are active High, and are defined in PSDsoft Express.
 4. Only address Bits A11-A0 are used in instruction decoding.
 5. No Unlock or instruction cycles are required when the device is in the READ Mode
 6. The RESET instruction is required to return to the READ Mode after reading the Flash ID, or after reading the Sector Protection Status, or if the Error Flag Bit (DQ5/DQ13) goes High.
 7. Additional sectors to be erased must be written at the end of the Sector Erase instruction within 80µs.
 8. The data is 00h for an unprotected sector, and 01h for a protected sector. In the fourth cycle, the Sector Select is active, and (A1,A0)=(1,0)
 9. The Unlock Bypass instruction is required prior to the Unlock Bypass Program instruction.
 10. The Unlock Bypass Reset Flash instruction is required to return to reading memory data when the device is in the Unlock Bypass Mode.
 11. The system may perform READ and Program cycles in non-erasing sectors, read the Flash ID or read the Sector Protection Status when in the Suspend Sector Erase Mode. The Suspend Sector Erase instruction is valid only during a Sector Erase cycle.
 12. The Resume Sector Erase instruction is valid only during the Suspend Sector Erase Mode.
 13. The MCU cannot invoke these instructions while executing code from the same Flash memory as that for which the instruction is intended. The MCU must retrieve, for example, the code from the secondary Flash memory when reading the Sector Protection Status of the primary Flash memory.

Power-down Instruction and Power-up Mode

Power-up Mode. The PSD MODULE internal logic is reset upon Power-up to the READ Mode. Sector Select (FS0-FS7 and CSBOOT0-CSBOOT3) must be held Low, and WRITE Strobe (WR, CNTL0) High, during Power-up for maximum security of the data contents and to remove the possibility of a byte being written on the first edge of WRITE Strobe (WR, CNTL0). Any WRITE cycle initiation is locked when V_{CC} is below V_{LKO}.

READ

Under typical conditions, the MCU may read the primary Flash memory or the secondary Flash memory using READ operations just as it would a ROM or RAM device. Alternately, the MCU may use READ operations to obtain status information about a Program or Erase cycle that is currently in progress. Lastly, the MCU may use instructions to read special data from these memory blocks. The following sections describe these READ functions.

READ Memory Contents. Primary Flash memory and secondary Flash memory are placed in the READ Mode after Power-up, chip reset, or a Reset Flash instruction (see Table 85, page 109). The MCU can read the memory contents of the primary Flash memory or the secondary Flash memory by using READ operations any time the READ operation is not part of an instruction.

READ Primary Flash Identifier. The primary Flash memory identifier (E7h) is read with an instruction composed of 4 operations: 3 specific WRITE operations and a READ operation (see Table 85). During the READ operation, Address Bits A6, A1, and A0 must be '0,' '0,' and '1,' respectively, and the appropriate Sector Select (FS0-FS7) must be High.

READ Memory Sector Protection Status. The primary Flash memory Sector Protection Status is read with an instruction composed of 4 operations: 3 specific WRITE operations and a READ operation (see Table 85). During the READ operation, address Bits A6, A1, and A0 must be '0,' '1,' and '0,' respectively, while Sector Select (FS0-FS7 or CSBOOT0-CSBOOT3) designates the Flash memory sector whose protection has to be verified. The READ operation produces 01h if the Flash memory sector is protected, or 00h if the sector is not protected.

The sector protection status for all NVM blocks (primary Flash memory or secondary Flash memory) can also be read by the MCU accessing the Flash Protection registers in PSD I/O space. See the section entitled "Flash Memory Sector Protect," page 115, for register definitions.

Reading the Erase/Program Status Bits. The Flash memory provides several status bits to be used by the MCU to confirm the completion of an Erase or Program cycle of Flash memory. These status bits minimize the time that the MCU spends performing these tasks and are defined in Table 86, page 111. The status bits can be read as many times as needed.

For Flash memory, the MCU can perform a READ operation to obtain these status bits while an Erase or Program instruction is being executed by the embedded algorithm. See the section entitled "Programming Flash Memory," page 112, for details.

Data Polling Flag (DQ7). When erasing or programming in Flash memory, the Data Polling Flag Bit (DQ7) outputs the complement of the bit being entered for programming/writing on the DQ7 Bit. Once the Program instruction or the WRITE operation is completed, the true logic value is read on the Data Polling Flag Bit (DQ7) (in a READ operation).

- Data Polling is effective after the fourth WRITE pulse (for a Program instruction) or after the sixth WRITE pulse (for an Erase instruction). It must be performed at the address being programmed or at an address within the Flash memory sector being erased.
- During an Erase cycle, the Data Polling Flag Bit (DQ7) outputs a '0.' After completion of the cycle, the Data Polling Flag Bit (DQ7) outputs the last bit programmed (it is a '1' after erasing).
- If the byte to be programmed is in a protected Flash memory sector, the instruction is ignored.
- If all the Flash memory sectors to be erased are protected, the Data Polling Flag Bit (DQ7) is reset to '0' for about 100µs, and then returns to the previous addressed byte. No erasure is performed.

Toggle Flag (DQ6). The Flash memory offers another way for determining when the Program cycle is completed. During the internal WRITE operation and when either the FS0-FS7 or CSBOOT0-CSBOOT3 is true, the Toggle Flag Bit (DQ6) toggles from '0' to '1' and '1' to '0' on subsequent attempts to read any byte of the memory.

When the internal cycle is complete, the toggling stops and the data READ on the Data Bus D0-D7 is the addressed memory byte. The device is now accessible for a new READ or WRITE operation. The cycle is finished when two successive Reads yield the same output data.

- The Toggle Flag Bit (DQ6) is effective after the fourth WRITE pulse (for a Program instruction) or after the sixth WRITE pulse (for an Erase instruction).
- If the byte to be programmed belongs to a protected Flash memory sector, the instruction is ignored.
- If all the Flash memory sectors selected for erasure are protected, the Toggle Flag Bit (DQ6) toggles to '0' for about 100μs and then returns to the previous addressed byte.

Error Flag (DQ5). During a normal Program or Erase cycle, the Error Flag Bit (DQ5) is to '0.' This

bit is set to '1' when there is a failure during Flash memory Byte Program, Sector Erase, or Bulk Erase cycle.

In the case of Flash memory programming, the Error Flag Bit (DQ5) indicates the attempt to program a Flash memory bit from the programmed state, '0', to the erased state, '1,' which is not valid. The Error Flag Bit (DQ5) may also indicate a Time-out condition while attempting to program a byte.

In case of an error in a Flash memory Sector Erase or Byte Program cycle, the Flash memory sector in which the error occurred or to which the programmed byte belongs must no longer be used. Other Flash memory sectors may still be used. The Error Flag Bit (DQ5) is reset after a Reset Flash instruction.

Erase Time-out Flag (DQ3). The Erase Time-out Flag Bit (DQ3) reflects the time-out period allowed between two consecutive Sector Erase instructions. The Erase Time-out Flag Bit (DQ3) is reset to '0' after a Sector Erase cycle for a time period of 100μs + 20% unless an additional Sector Erase instruction is decoded. After this time period, or when the additional Sector Erase instruction is decoded, the Erase Time-out Flag Bit (DQ3) is set to '1.'

Table 86. Status Bit

Functional Block	FS0-FS7/CSBOOT0-CSBOOT3	DQ7	DQ6	DQ5	DQ4	DQ3	DQ2	DQ1	DQ0
Flash Memory	V _{IH}	Data Polling	Toggle Flag	Error Flag	X	Erase Time-out	X	X	X

Note: 1. X = Not guaranteed value, can be read either '1' or '0.'
 2. DQ7-DQ0 represent the Data Bus bits, D7-D0.
 3. FS0-FS7 and CSBOOT0-CSBOOT3 are active High.

Programming Flash Memory

Flash memory must be erased prior to being programmed. A byte of Flash memory is erased to all '1s' (FFh), and is programmed by setting selected bits to '0.' The MCU may erase Flash memory all at once or by-sector, but not byte-by-byte. However, the MCU may program Flash memory byte-by-byte.

The primary and secondary Flash memories require the MCU to send an instruction to program a byte or to erase sectors (see Table 85).

Once the MCU issues a Flash memory Program or Erase instruction, it must check for the status bits for completion. The embedded algorithms that are invoked support several means to provide status to the MCU. Status may be checked using any of three methods: Data Polling, Data Toggle, or Ready/Busy (PC3).

Data Polling. Polling on the Data Polling Flag Bit (DQ7) is a method of checking whether a Program or Erase cycle is in progress or has completed. Figure 52 shows the Data Polling algorithm.

When the MCU issues a Program instruction, the embedded algorithm begins. The MCU then reads the location of the byte to be programmed in Flash memory to check status. The Data Polling Flag Bit (DQ7) of this location becomes the complement of b7 of the original data byte to be programmed. The MCU continues to poll this location, comparing the Data Polling Flag Bit (DQ7) and monitoring the Error Flag Bit (DQ5). When the Data Polling Flag Bit (DQ7) matches b7 of the original data, and the Error Flag Bit (DQ5) remains '0,' the embedded algorithm is complete. If the Error Flag Bit (DQ5) is '1,' the MCU should test the Data Polling Flag Bit (DQ7) again since the Data Polling Flag Bit (DQ7) may have changed simultaneously with the Error Flag Bit (DQ5) (see Figure 52).

The Error Flag Bit (DQ5) is set if either an internal time-out occurred while the embedded algorithm attempted to program the byte or if the MCU attempted to program a '1' to a bit that was not erased (not erased is logic '0').

It is suggested (as with all Flash memories) to read the location again after the embedded programming algorithm has completed, to compare the

byte that was written to the Flash memory with the byte that was intended to be written.

When using the Data Polling method during an Erase cycle, Figure 52 still applies. However, the Data Polling Flag Bit (DQ7) is '0' until the Erase cycle is complete. A '1' on the Error Flag Bit (DQ5) indicates a time-out condition on the Erase cycle; a '0' indicates no error. The MCU can read any location within the sector being erased to get the Data Polling Flag Bit (DQ7) and the Error Flag Bit (DQ5).

PSDsoft Express generates ANSI C code functions which implement these Data Polling algorithms.

Figure 52. Data Polling Flowchart

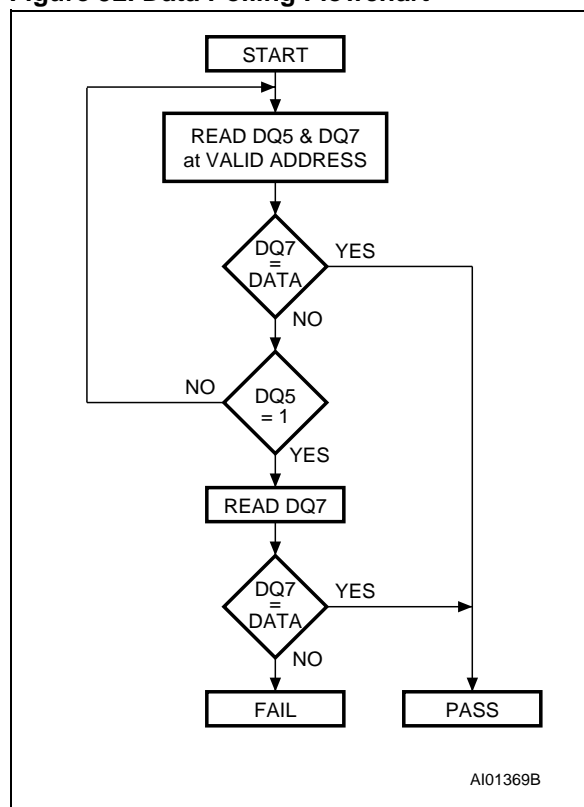

Data Toggle. Checking the Toggle Flag Bit (DQ6) is a method of determining whether a Program or Erase cycle is in progress or has completed. Figure 53 shows the Data Toggle algorithm.

When the MCU issues a Program instruction, the embedded algorithm begins. The MCU then reads the location of the byte to be programmed in Flash memory to check status. The Toggle Flag Bit (DQ6) of this location toggles each time the MCU reads this location until the embedded algorithm is complete. The MCU continues to read this location, checking the Toggle Flag Bit (DQ6) and monitoring the Error Flag Bit (DQ5). When the Toggle Flag Bit (DQ6) stops toggling (two consecutive reads yield the same value), and the Error Flag Bit (DQ5) remains '0,' the embedded algorithm is complete. If the Error Bit (DQ5) is '1,' the MCU should test the Toggle Flag Bit (DQ6) again, since the Toggle Flag Bit (DQ6) may have changed simultaneously with the Error Flag Bit (DQ5) (see Figure 53).

The Error Flag Bit(DQ5) is set if either an internal time-out occurred while the embedded algorithm attempted to program the byte, or if the MCU attempted to program a '1' to a bit that was not erased (not erased is logic '0').

It is suggested (as with all Flash memories) to read the location again after the embedded programming algorithm has completed, to compare the byte that was written to Flash memory with the byte that was intended to be written.

When using the Data Toggle method after an Erase cycle, Figure 53 still applies. the Toggle Flag Bit (DQ6) toggles until the Erase cycle is complete. A 1 on the Error Flag Bit (DQ5) indicates a time-out condition on the Erase cycle; a '0' indi-

cates no error. The MCU can read any location within the sector being erased to get the Toggle Flag Bit (DQ6) and the Error Flag Bit (DQ5).

PSDsoft Express generates ANSI C code functions which implement these Data Toggling algorithms.

Figure 53. Data Toggle Flowchart

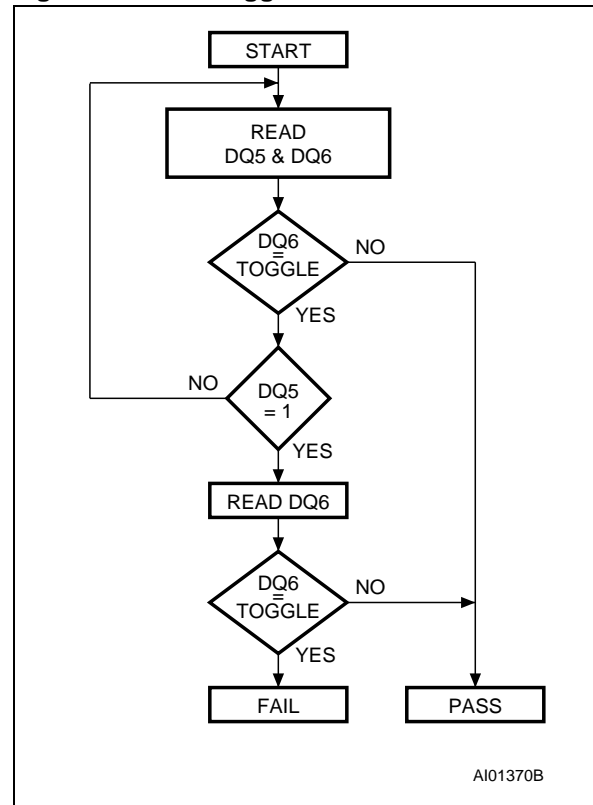

Unlock Bypass. The Unlock Bypass instructions allow the system to program bytes to the Flash memories faster than using the standard Program instruction. The Unlock Bypass Mode is entered by first initiating two Unlock cycles. This is followed by a third WRITE cycle containing the Unlock Bypass code, 20h (as shown in Table 85).

The Flash memory then enters the Unlock Bypass Mode. A two-cycle Unlock Bypass Program instruction is all that is required to program in this mode. The first cycle in this instruction contains the Unlock Bypass Program code, A0h. The second cycle contains the program address and data. Additional data is programmed in the same manner. These instructions dispense with the initial two Unlock cycles required in the standard Program instruction, resulting in faster total Flash memory programming.

During the Unlock Bypass Mode, only the Unlock Bypass Program and Unlock Bypass Reset Flash instructions are valid.

To exit the Unlock Bypass Mode, the system must issue the two-cycle Unlock Bypass Reset Flash instruction. The first cycle must contain the data 90h; the second cycle the data 00h. Addresses are Don't Care for both cycles. The Flash memory then returns to READ Mode.

Erasing Flash Memory

Flash Bulk Erase. The Flash Bulk Erase instruction uses six WRITE operations followed by a READ operation of the status register, as described in Table 85. If any byte of the Bulk Erase instruction is wrong, the Bulk Erase instruction aborts and the device is reset to the READ Flash memory status.

During a Bulk Erase, the memory status may be checked by reading the Error Flag Bit (DQ5), the Toggle Flag Bit (DQ6), and the Data Polling Flag Bit (DQ7), as detailed in the section entitled "Programming Flash Memory," page 112. The Error Flag Bit (DQ5) returns a '1' if there has been an Erase Failure (maximum number of Erase cycles have been executed).

It is not necessary to program the memory with 00h because the PSD MODULE automatically does this before erasing to 0FFh.

During execution of the Bulk Erase instruction, the Flash memory does not accept any instructions.

Flash Sector Erase. The Sector Erase instruction uses six WRITE operations, as described in Table 85. Additional Flash Sector Erase codes and Flash memory sector addresses can be written subsequently to erase other Flash memory sectors in parallel, without further coded cycles, if the additional bytes are transmitted in a shorter time than the time-out period of about 100µs. The

input of a new Sector Erase code restarts the time-out period.

The status of the internal timer can be monitored through the level of the Erase Time-out Flag Bit (DQ3). If the Erase Time-out Flag Bit (DQ3) is '0,' the Sector Erase instruction has been received and the time-out period is counting. If the Erase Time-out Flag Bit (DQ3) is '1,' the time-out period has expired and the embedded algorithm is busy erasing the Flash memory sector(s). Before and during Erase time-out, any instruction other than Suspend Sector Erase and Resume Sector Erase instructions abort the cycle that is currently in progress, and reset the device to READ Mode.

During a Sector Erase, the memory status may be checked by reading the Error Flag Bit (DQ5), the Toggle Flag Bit (DQ6), and the Data Polling Flag Bit (DQ7), as detailed in the section entitled "Programming Flash Memory," page 112.

During execution of the Erase cycle, the Flash memory accepts only RESET and Suspend Sector Erase instructions. Erasure of one Flash memory sector may be suspended, in order to read data from another Flash memory sector, and then resumed.

Suspend Sector Erase. When a Sector Erase cycle is in progress, the Suspend Sector Erase instruction can be used to suspend the cycle by writing 0B0h to any address when an appropriate Sector Select (FS0-FS7 or CSBOOT0-CSBOOT3) is High. (See Table 85). This allows reading of data from another Flash memory sector after the Erase cycle has been suspended. Suspend Sector Erase is accepted only during an Erase cycle and defaults to READ Mode. A Suspend Sector Erase instruction executed during an Erase time-out period, in addition to suspending the Erase cycle, terminates the time out period.

The Toggle Flag Bit (DQ6) stops toggling when the internal logic is suspended. The status of this bit must be monitored at an address within the Flash memory sector being erased. The Toggle Flag Bit (DQ6) stops toggling between 0.1µs and 15µs after the Suspend Sector Erase instruction has been executed. The Flash memory is then automatically set to READ Mode.

If an Suspend Sector Erase instruction was executed, the following rules apply:

- Attempting to read from a Flash memory sector that was being erased outputs invalid data.
- Reading from a Flash sector that was *not* being erased is valid.
- The Flash memory *cannot* be programmed, and only responds to Resume Sector Erase and Reset Flash instructions (READ is an operation and is allowed).

– If a Reset Flash instruction is received, data in the Flash memory sector that was being erased is invalid.

Resume Sector Erase. If a Suspend Sector Erase instruction was previously executed, the erase cycle may be resumed with this instruction. The Resume Sector Erase instruction consists of writing 030h to any address while an appropriate Sector Select (FS0-FS7 or CSBOOT0-CSBOOT3) is High. (See Table 85.)

Specific Features

Flash Memory Sector Protect. Each primary and secondary Flash memory sector can be separately protected against Program and Erase cycles. Sector Protection provides additional data security because it disables all Program or Erase cycles. This mode can be activated through the JTAG Port or a Device Programmer.

Sector protection can be selected for each sector using the PSDsoft Express Configuration program. This automatically protects selected sectors when the device is programmed through the JTAG Port or a Device Programmer. Flash memory sectors can be unprotected to allow updating of their contents using the JTAG Port or a Device Programmer. The MCU can read (but cannot change) the sector protection bits.

Any attempt to program or erase a protected Flash memory sector is ignored by the device. The Verify operation results in a READ of the protected data. This allows a guarantee of the retention of the Protection status.

The sector protection status can be read by the MCU through the Flash memory protection registers (in the CSIOP block). See Table 87 and Table 88.

Table 87. Sector Protection/Security Bit Definition – Flash Protection Register

Bit 7	Bit 6	Bit 5	Bit 4	Bit 3	Bit 2	Bit 1	Bit 0
Sec7_Prot	Sec6_Prot	Sec5_Prot	Sec4_Prot	Sec3_Prot	Sec2_Prot	Sec1_Prot	Sec0_Prot

Note: 1. Bit Definitions:

Sec<i>_Prot 1 = Primary Flash memory or secondary Flash memory Sector <i> is write-protected.

Sec<i>_Prot 0 = Primary Flash memory or secondary Flash memory Sector <i> is not write-protected.

Table 88. Sector Protection/Security Bit Definition – Secondary Flash Protection Register

Bit 7	Bit 6	Bit 5	Bit 4	Bit 3	Bit 2	Bit 1	Bit 0
Security_Bit	not used	not used	not used	Sec3_Prot	Sec2_Prot	Sec1_Prot	Sec0_Prot

Note: 1. Bit Definitions:

Sec<i>_Prot 1 = Secondary Flash memory Sector <i> is write-protected.

Sec<i>_Prot 0 = Secondary Flash memory Sector <i> is not write-protected.

Security_Bit 0 = Security Bit in device has not been set.

1 = Security Bit in device has been set.

Reset Flash. The Reset Flash instruction consists of one WRITE cycle (see Table 85). It can also be optionally preceded by the standard two WRITE decoding cycles (writing AAh to 555h and 55h to AAAh). It must be executed after:

- Reading the Flash Protection Status or Flash ID
- An Error condition has occurred (and the device has set the Error Flag Bit (DQ5) to '1' during a Flash memory Program or Erase cycle.

The Reset Flash instruction puts the Flash memory back into normal READ Mode. If an Error condition has occurred (and the device has set the Error Flag Bit (DQ5) to '1' the Flash memory is put back into normal READ Mode within 25μs of the Reset Flash instruction having been issued. The Reset Flash instruction is ignored when it is issued during a Program or Bulk Erase cycle of the Flash memory. The Reset Flash instruction aborts any on-going Sector Erase cycle, and returns the Flash memory to the normal READ Mode within 25μs.

Reset (RESET) Signal. A pulse on Reset ($\overline{\text{RESET}}$) aborts any cycle that is in progress, and resets the Flash memory to the READ Mode. When the reset occurs during a Program or Erase cycle, the Flash memory takes up to 25μs to return to the READ Mode. It is recommended that the Reset (RESET) pulse (except for Power-on RESET, as described on page 140) be at least 25μs so that the Flash memory is always ready for the MCU to retrieve the bootstrap instructions after the reset cycle is complete.

SRAM

The SRAM is enabled when SRAM Select (RS0) from the DPLD is High. SRAM Select (RS0) can contain up to two product terms, allowing flexible memory mapping.

The SRAM can be backed up using an external battery. The external battery should be connected to Voltage Stand-by (V_{STBY} , PC2). If you have an external battery connected to the μPSD325X de-

vices, the contents of the SRAM are retained in the event of a power loss. The contents of the SRAM are retained so long as the battery voltage remains at 2V or greater. If the supply voltage falls below the battery voltage, an internal power switch-over to the battery occurs.

PC4 can be configured as an output that indicates when power is being drawn from the external battery. Battery-on Indicator (V_{BATON} , PC4) is High with the supply voltage falls below the battery voltage and the battery on Voltage Stand-by (V_{STBY} , PC2) is supplying power to the internal SRAM.

SRAM Select (RS0), Voltage Stand-by (V_{STBY} , PC2) and Battery-on Indicator (V_{BATON} , PC4) are all configured using PSDsoft Express Configuration.

Sector Select and SRAM Select

Sector Select (FS0-FS7, CSBOOT0-CSBOOT3) and SRAM Select (RS0) are all outputs of the DPLD. They are setup by writing equations for them in PSDsoft Express. The following rules apply to the equations for these signals:

1. Primary Flash memory and secondary Flash memory Sector Select signals must *not* be larger than the physical sector size.
2. Any primary Flash memory sector must *not* be mapped in the same memory space as another Flash memory sector.
3. A secondary Flash memory sector must *not* be mapped in the same memory space as another secondary Flash memory sector.
4. SRAM, I/O, and Peripheral I/O spaces must *not* overlap.
5. A secondary Flash memory sector *may* overlap a primary Flash memory sector. In case of overlap, priority is given to the secondary Flash memory sector.
6. SRAM, I/O, and Peripheral I/O spaces *may* overlap any other memory sector. Priority is given to the SRAM, I/O, or Peripheral I/O.

Example. FS0 is valid when the address is in the range of 8000h to BFFFh, CSBOOT0 is valid from 8000h to 9FFFh, and RS0 is valid from 8000h to 87FFh. Any address in the range of RS0 always accesses the SRAM. Any address in the range of CSBOOT0 greater than 87FFh (and less than 9FFFh) automatically addresses secondary Flash memory segment 0. Any address greater than 9FFFh accesses the primary Flash memory segment 0. You can see that half of the primary Flash memory segment 0 and one-fourth of secondary Flash memory segment 0 cannot be accessed in this example.

Note: An equation that defined FS1 to anywhere in the range of 8000h to BFFFh would *not* be valid.

Figure 54 shows the priority levels for all memory components. Any component on a higher level can overlap and has priority over any component on a lower level. Components on the same level must *not* overlap. Level one has the highest priority and level 3 has the lowest.

Memory Select Configuration in Program and Data Spaces. The MCU Core has separate address spaces for Program memory and Data memory. Any of the memories within the PSD MODULE can reside in either space or both spaces. This is controlled through manipulation of the VM Register that resides in the CSIOP space.

The VM Register is set using PSDsoft Express to have an initial value. It can subsequently be

changed by the MCU so that memory mapping can be changed on-the-fly.

For example, you may wish to have SRAM and primary Flash memory in the Data space at Boot-up, and secondary Flash memory in the Program space at Boot-up, and later swap the primary and secondary Flash memories. This is easily done with the VM Register by using PSDsoft Express Configuration to configure it for Boot-up and having the MCU change it when desired. Table 89 describes the VM Register.

Figure 54. Priority Level of Memory and I/O Components in the PSD MODULE

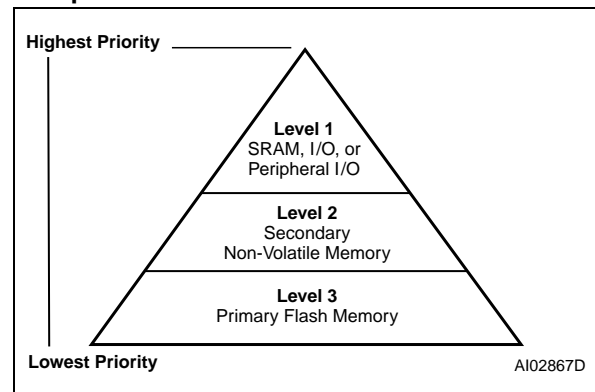

Table 89. VM Register

Bit 7 PIO_EN	Bit 6	Bit 5	Bit 4 Primary FL_Data	Bit 3 Secondary Data	Bit 2 Primary FL_Code	Bit 1 Secondary Code	Bit 0 SRAM_Code
0 = disable PIO Mode	not used	not used	0 = \overline{RD} can't access Flash memory	0 = \overline{RD} can't access Secondary Flash memory	0 = \overline{PSEN} can't access Flash memory	0 = \overline{PSEN} can't access Secondary Flash memory	0 = \overline{PSEN} can't access SRAM
1 = enable PIO Mode	not used	not used	1 = \overline{RD} access Flash memory	1 = \overline{RD} access Secondary Flash memory	1 = \overline{PSEN} access Flash memory	1 = \overline{PSEN} access Secondary Flash memory	1 = \overline{PSEN} access SRAM

Separate Space Mode. Program space is separated from Data space. For example, Program Select Enable ($\overline{\text{PSEN}}$) is used to access the program code from the primary Flash memory, while READ Strobe ($\overline{\text{RD}}$) is used to access data from the secondary Flash memory, SRAM and I/O Port blocks. This configuration requires the VM Register to be set to 0Ch (see Figure 55).

Combined Space Modes. The Program and Data spaces are combined into one memory space that allows the primary Flash memory, secondary Flash memory, and SRAM to be accessed by either Program Select Enable ($\overline{\text{PSEN}}$) or READ Strobe ($\overline{\text{RD}}$). For example, to configure the primary Flash memory in Combined space, Bits b2 and b4 of the VM Register are set to '1' (see Figure 56).

Figure 55. Separate Space Mode

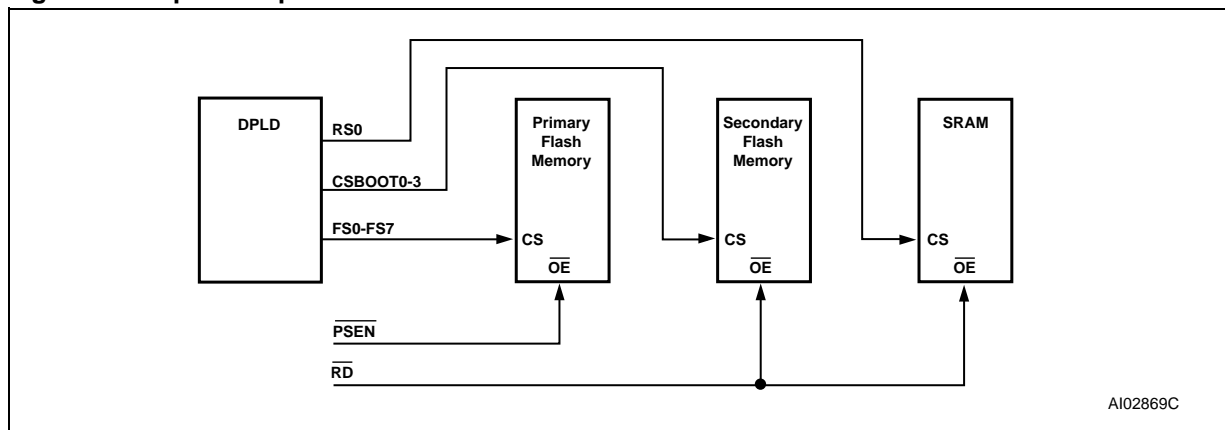
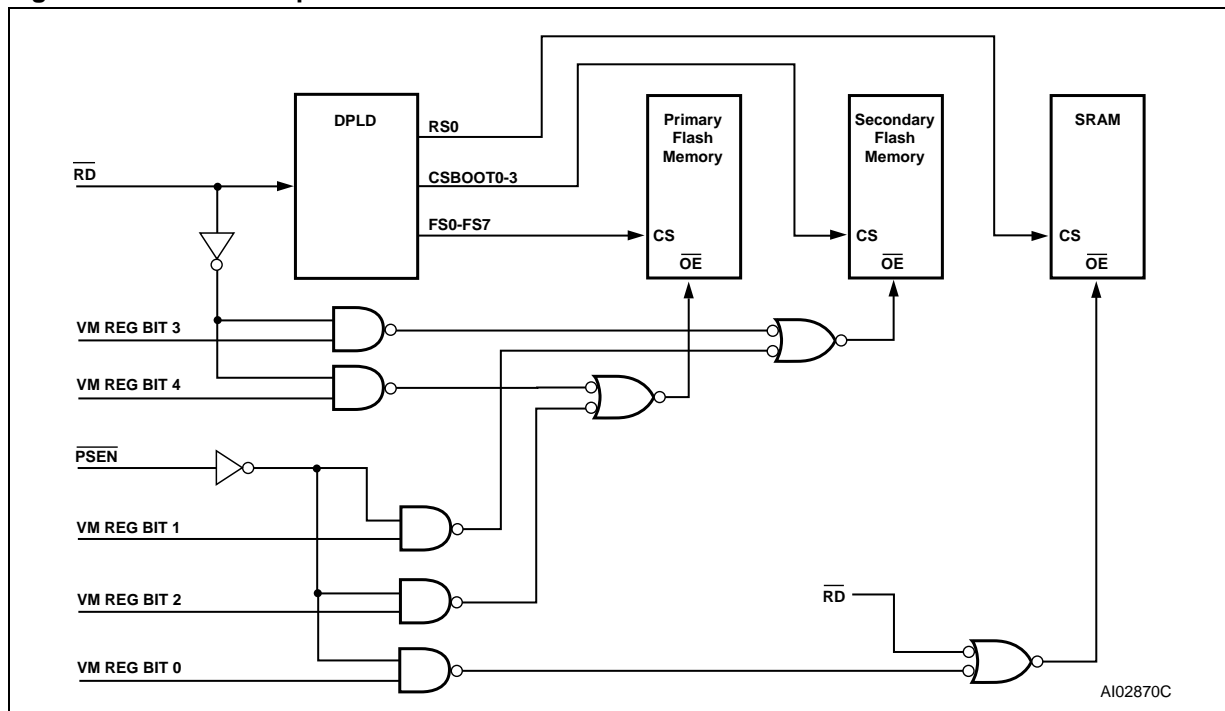

Figure 56. Combined Space Mode



Page Register

The 8-bit Page Register increases the addressing capability of the MCU Core by a factor of up to 256. The contents of the register can also be read by the MCU. The outputs of the Page Register (PGR0-PGR7) are inputs to the DPLD decoder and can be included in the Sector Select (FS0-FS7, CSBOOT0-CSBOOT3), and SRAM Select (RS0) equations.

If memory paging is not needed, or if not all 8 page register bits are needed for memory paging, then these bits may be used in the CPLD for general logic.

Figure 57 shows the Page Register. The eight flip-flops in the register are connected to the internal data bus D0-D7. The MCU can write to or read from the Page Register. The Page Register can be accessed at address location CSIOP + E0h.

Figure 57. Page Register

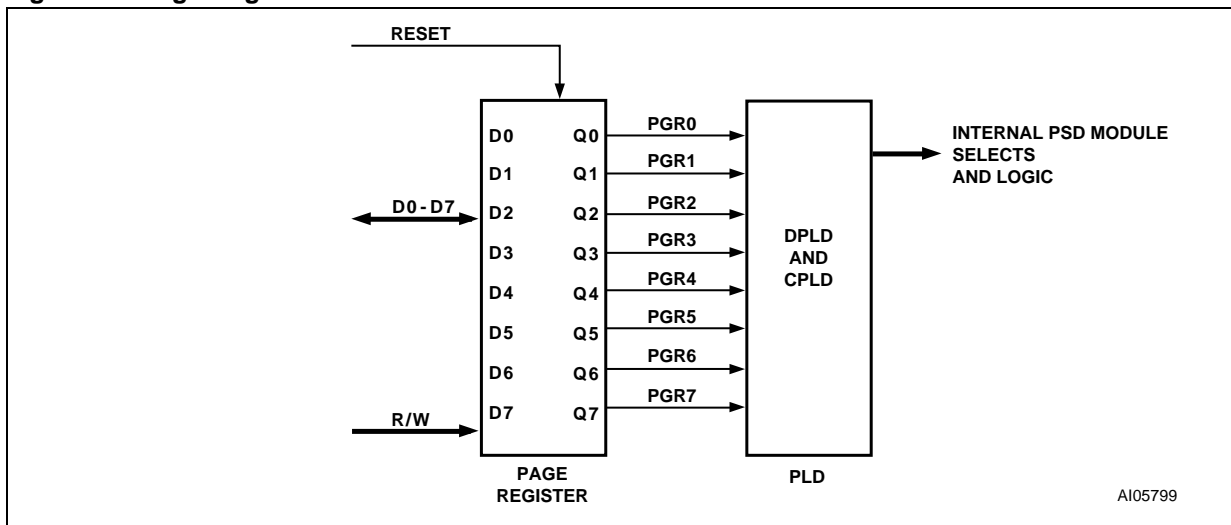

PLDS

The PLDs bring programmable logic functionality to the μPSD. After specifying the logic for the PLDs in PSDsoft Express, the logic is programmed into the device and available upon Power-up.

Table 90. DPLD and CPLD Inputs

Input Source	Input Name	Number of Signals
MCU Address Bus	A15-A0	16
MCU Control Signals	$\overline{\text{PSEN}}$, $\overline{\text{RD}}$, $\overline{\text{WR}}$, ALE	4
RESET	$\overline{\text{RST}}$	1
Power-down	PDN	1
Port A Input Macrocells ¹	PA7-PA0	8
Port B Input Macrocells	PB7-PB0	8
Port C Input Macrocells	PC7-PC0	8
Port D Inputs	PD2-PD1	2
Page Register	PGR7-PGR0	8
Macrocell AB Feedback	MCELLAB.FB7-FB0	8
Macrocell BC Feedback	MCELLBC.FB7-FB0	8
Flash memory Program Status Bit	Ready/ $\overline{\text{Busy}}$	1

Note: 1. These inputs are not available in the 52-pin package.

The PSD MODULE contains two PLDs: the Decode PLD (DPLD), and the Complex PLD (CPLD). The PLDs are briefly discussed in the next few paragraphs, and in more detail in the section entitled “Decode PLD (DPLD),” page 122, and the section entitled “Complex PLD (CPLD),” page 123. Figure 58 shows the configuration of the PLDs.

The DPLD performs address decoding for Select signals for PSD MODULE components, such as memory, registers, and I/O ports.

The CPLD can be used for logic functions, such as loadable counters and shift registers, state machines, and encoding and decoding logic. These logic functions can be constructed using the Output Macrocells (OMC), Input Macrocells (IMC), and the AND Array. The CPLD can also be used to generate External Chip Select (ECS1-ECS2) signals.

The AND Array is used to form product terms. These product terms are specified using PSDsoft. The PLD input signals consist of internal MCU signals and external inputs from the I/O ports. The input signals are shown in Table 90.

The Turbo Bit in PSD MODULE

The PLDs can minimize power consumption by switching off when inputs remain unchanged for an extended time of about 70ns. Resetting the Turbo Bit to '0' (Bit 3 of PMMR0) automatically places the PLDs into standby if no inputs are changing. Turning the Turbo Mode off increases propagation delays while reducing power consumption. See the section entitled “POWER MANAGEMENT,” page 136, on how to set the Turbo Bit.

Additionally, five bits are available in PMMR2 to block MCU control signals from entering the PLDs. This reduces power consumption and can be used only when these MCU control signals are not used in PLD logic equations.

Each of the two PLDs has unique characteristics suited for its applications. They are described in the following sections.



Figure 58. PLD Diagram

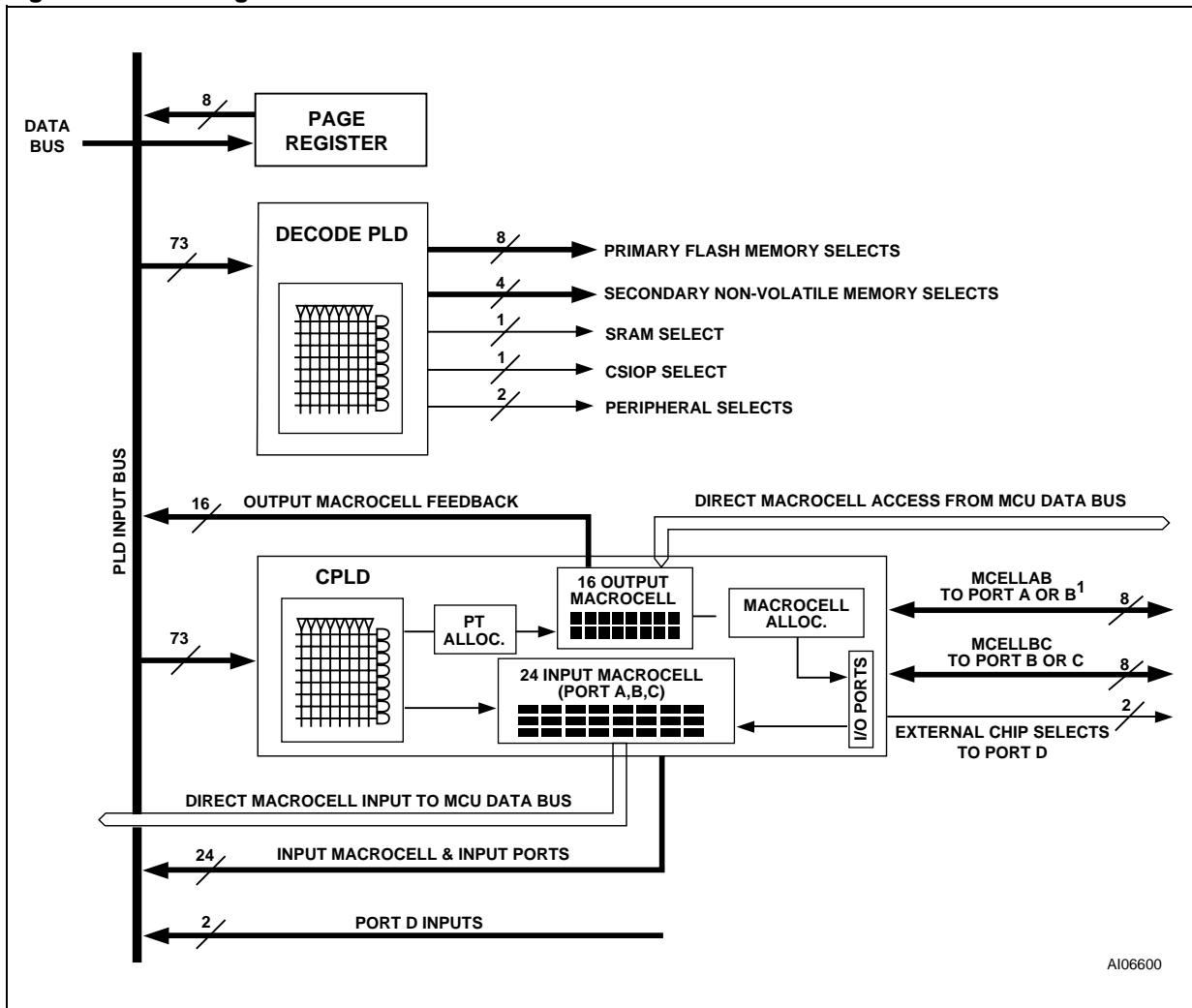

Note: 1. Ports A is not available in the 52-pin package

Decode PLD (DPLD)

The DPLD, shown in Figure 59, is used for decoding the address for PSD MODULE and external components. The DPLD can be used to generate the following decode signals:

- 8 Sector Select (FS0-FS7) signals for the primary Flash memory (three product terms each)
- 4 Sector Select (CSBOOT0-CSBOOT3) signals for the secondary Flash memory (three product terms each)
- 1 internal SRAM Select (RS0) signal (two product terms)
- 1 internal CSIOP Select signal (selects the PSD MODULE registers)
- 2 internal Peripheral Select signals (Peripheral I/O Mode).

Figure 59. DPLD Logic Array

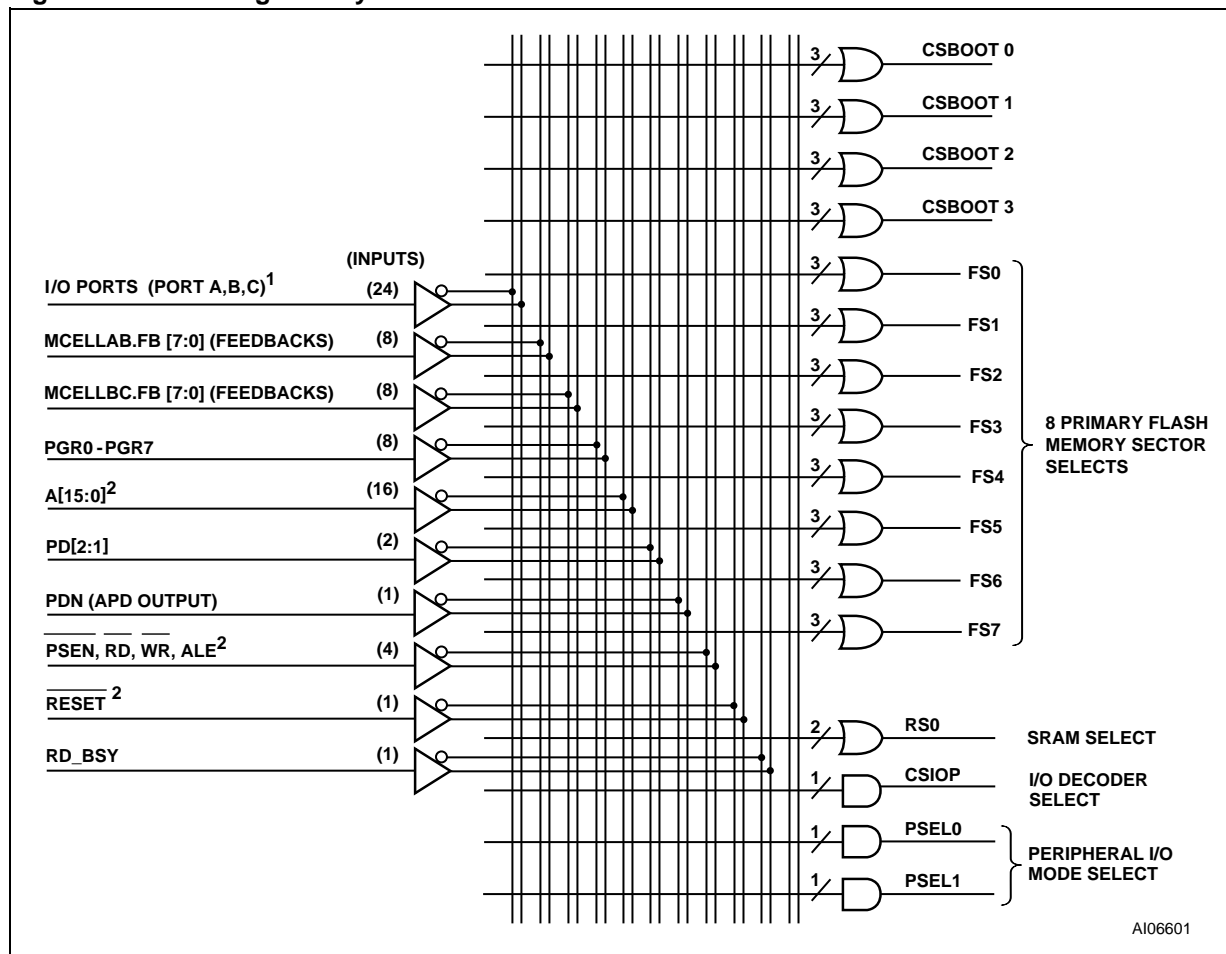

Note: 1. Port A inputs are not available in the 52-pin package
 2. Inputs from the MCU module

Complex PLD (CPLD)

The CPLD can be used to implement system logic functions, such as loadable counters and shift registers, system mailboxes, handshaking protocols, state machines, and random logic. The CPLD can also be used to generate External Chip Select (ECS1-ECS2), routed to Port D.

Although External Chip Select (ECS1-ECS2) can be produced by any Output Macrocell (OMC), these External Chip Select (ECS1-ECS2) on Port D do not consume any Output Macrocells (OMC).

As shown in Figure 58, the CPLD has the following blocks:

- 24 Input Macrocells (IMC)
- 16 Output Macrocells (OMC)
- Macrocell Allocator
- Product Term Allocator

- AND Array capable of generating up to 137 product terms
- Four I/O Ports.

Each of the blocks are described in the sections that follow.

The Input Macrocells (IMC) and Output Macrocells (OMC) are connected to the PSD MODULE internal data bus and can be directly accessed by the MCU. This enables the MCU software to load data into the Output Macrocells (OMC) or read data from both the Input and Output Macrocells (IMC and OMC).

This feature allows efficient implementation of system logic and eliminates the need to connect the data bus to the AND Array as required in most standard PLD macrocell architectures.

Figure 60. Macrocell and I/O Port

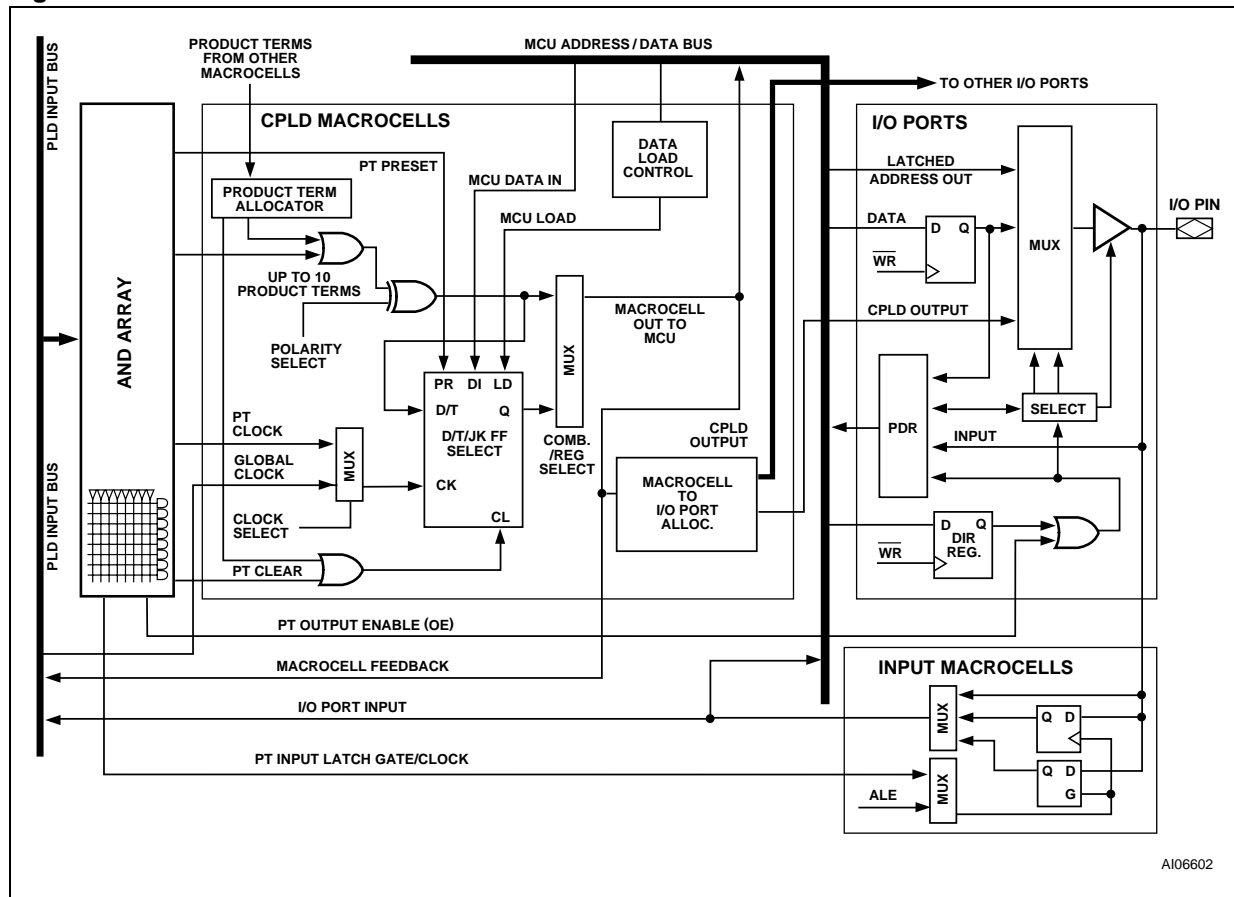

Output Macrocell (OMC)

Eight of the Output Macrocells (OMC) are connected to Ports A and B pins and are named as McellAB0-McellAB7. The other eight macrocells are connected to Ports B and C pins and are named as McellBC0-McellBC7. If an McellAB output is not assigned to a specific pin in PSDsoft, the Macrocell Allocator block assigns it to either Port A or B. The same is true for a McellBC output on Port B or C. Table 91 shows the macrocells and port assignment.

The Output Macrocell (OMC) architecture is shown in Figure 61. As shown in the figure, there are native product terms available from the AND Array, and borrowed product terms available (if unused) from other Output Macrocells (OMC). The polarity of the product term is controlled by the

XOR gate. The Output Macrocell (OMC) can implement either sequential logic, using the flip-flop element, or combinatorial logic. The multiplexer selects between the sequential or combinatorial logic outputs. The multiplexer output can drive a port pin and has a feedback path to the AND Array inputs.

The flip-flop in the Output Macrocell (OMC) block can be configured as a D, T, JK, or SR type in PSDsoft. The flip-flop’s clock, preset, and clear inputs may be driven from a product term of the AND Array. Alternatively, CLKIN (PD1) can be used for the clock input to the flip-flop. The flip-flop is clocked on the rising edge of CLKIN (PD1). The preset and clear are active High inputs. Each clear input can use up to two product terms.

Table 91. Output Macrocell Port and Data Bit Assignments

Output Macrocell	Port Assignment ¹	Native Product Terms	Maximum Borrowed Product Terms	Data Bit for Loading or Reading
McellAB0	Port A0, B0	3	6	D0
McellAB1	Port A1, B1	3	6	D1
McellAB2	Port A2, B2	3	6	D2
McellAB3	Port A3, B3	3	6	D3
McellAB4	Port A4, B4	3	6	D4
McellAB5	Port A5, B5	3	6	D5
McellAB6	Port A6, B6	3	6	D6
McellAB7	Port A7, B7	3	6	D7
McellBC0	Port B0, C0	4	5	D0
McellBC1	Port B1, C1	4	5	D1
McellBC2	Port B2, C2	4	5	D2
McellBC3	Port B3, C3	4	5	D3
McellBC4	Port B4, C4	4	6	D4
McellBC5	Port B5, C5	4	6	D5
McellBC6	Port B6, C6	4	6	D6
McellBC7	Port B7, C7	4	6	D7

Note: 1. McellAB0-McellAB7 can only be assigned to Port B in the 52-pin package

The OMC Mask Register. There is one Mask Register for each of the two groups of eight Output Macrocells (OMC). The Mask Registers can be used to block the loading of data to individual Output Macrocells (OMC). The default value for the Mask Registers is 00h, which allows loading of the Output Macrocells (OMC). When a given bit in a Mask Register is set to a '1,' the MCU is blocked from writing to the associated Output Macrocells (OMC). For example, suppose McellAB0-McellAB3 are being used for a state machine. You would not want a MCU write to McellAB to overwrite the state machine registers. Therefore, you would want to load the Mask Register for McellAB (Mask Macrocell AB) with the value 0Fh.

The Output Enable of the OMC. The Output Macrocells (OMC) block can be connected to an I/O port pin as a PLD output. The output enable of each port pin driver is controlled by a single product term from the AND Array, ORed with the Direction Register output. The pin is enabled upon Power-up if no output enable equation is defined and if the pin is declared as a PLD output in PSDsoft Express.

If the Output Macrocell (OMC) output is declared as an internal node and not as a port pin output in the PSDlabel file, the port pin can be used for other

I/O functions. The internal node feedback can be routed as an input to the AND Array.

Input Macrocells (IMC)

The CPLD has 24 Input Macrocells (IMC), one for each pin on Ports A, B, and C. The architecture of the Input Macrocells (IMC) is shown in Figure 62. The Input Macrocells (IMC) are individually configurable, and can be used as a latch, register, or to pass incoming Port signals prior to driving them onto the PLD input bus. The outputs of the Input Macrocells (IMC) can be read by the MCU through the internal data bus.

The enable for the latch and clock for the register are driven by a multiplexer whose inputs are a product term from the CPLD AND Array or the MCU Address Strobe (ALE). Each product term output is used to latch or clock four Input Macrocells (IMC). Port inputs 3-0 can be controlled by one product term and 7-4 by another.

Configurations for the Input Macrocells (IMC) are specified by equations written in PSDsoft (see Application Note AN1171). Outputs of the Input Macrocells (IMC) can be read by the MCU via the IMC buffer. See the section entitled "I/O PORTS (PSD MODULE)," page 127.

Figure 62. Input Macrocell

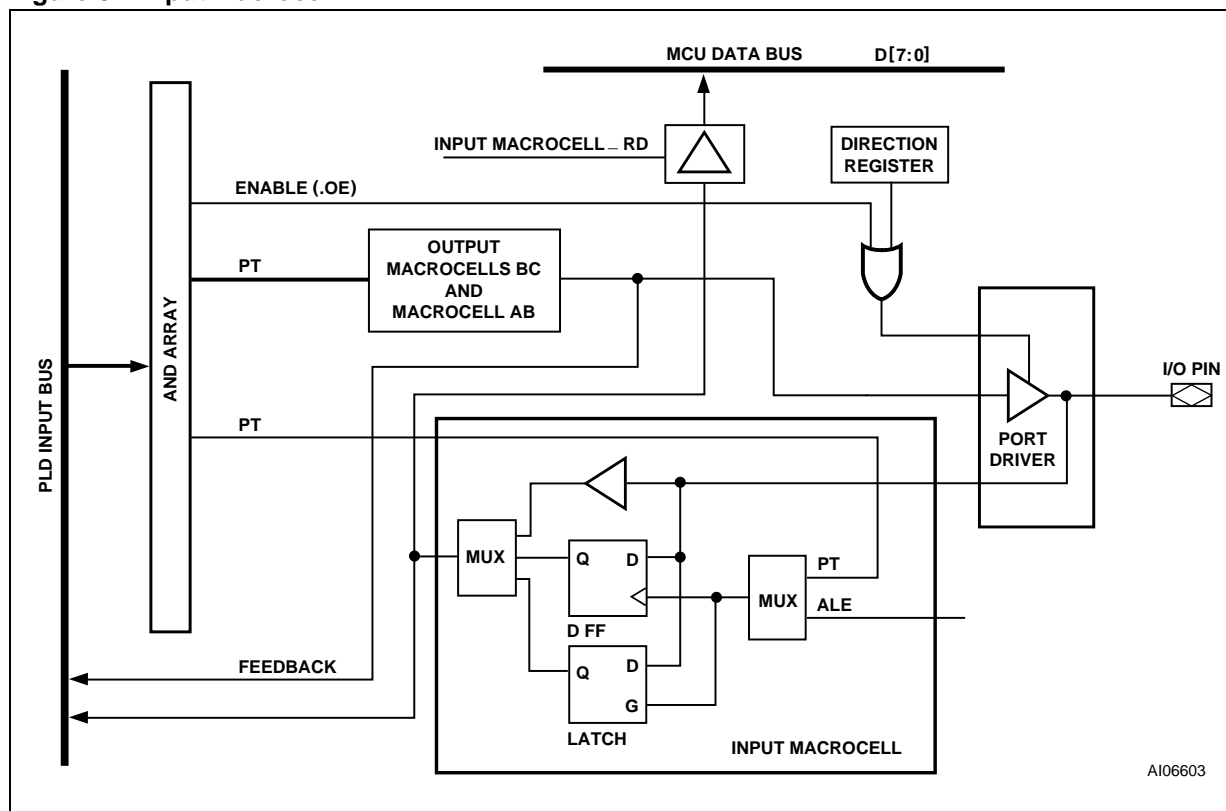

I/O PORTS (PSD MODULE)

There are four programmable I/O ports: Ports A, B, C, and D in the PSD MODULE. Each of the ports is eight bits except Port D, which is 3 bits. Each port pin is individually user configurable, thus allowing multiple functions per port. The ports are configured using PSDsoft Express Configuration or by the MCU writing to on-chip registers in the CSIOP space. Port A is not available in the 52-pin package.

The topics discussed in this section are:

- General Port architecture
- Port operating modes
- Port Configuration Registers (PCR)
- Port Data Registers
- Individual Port functionality.

General Port Architecture

The general architecture of the I/O Port block is shown in Figure 63. Individual Port architectures are shown in Figure 65 to Figure 68. In general, once the purpose for a port pin has been defined,

that pin is no longer available for other purposes. Exceptions are noted.

As shown in Figure 63, the ports contain an output multiplexer whose select signals are driven by the configuration bits in the Control Registers (Ports A and B only) and PSDsoft Express Configuration. Inputs to the multiplexer include the following:

- Output data from the Data Out register
- Latched address outputs
- CPLD macrocell output
- External Chip Select (ECS1-ECS2) from the CPLD.

The Port Data Buffer (PDB) is a tri-state buffer that allows only one source at a time to be read. The Port Data Buffer (PDB) is connected to the Internal Data Bus for feedback and can be read by the MCU. The Data Out and macrocell outputs, Direction and Control Registers, and port pin input are all connected to the Port Data Buffer (PDB).

Figure 63. General I/O Port Architecture

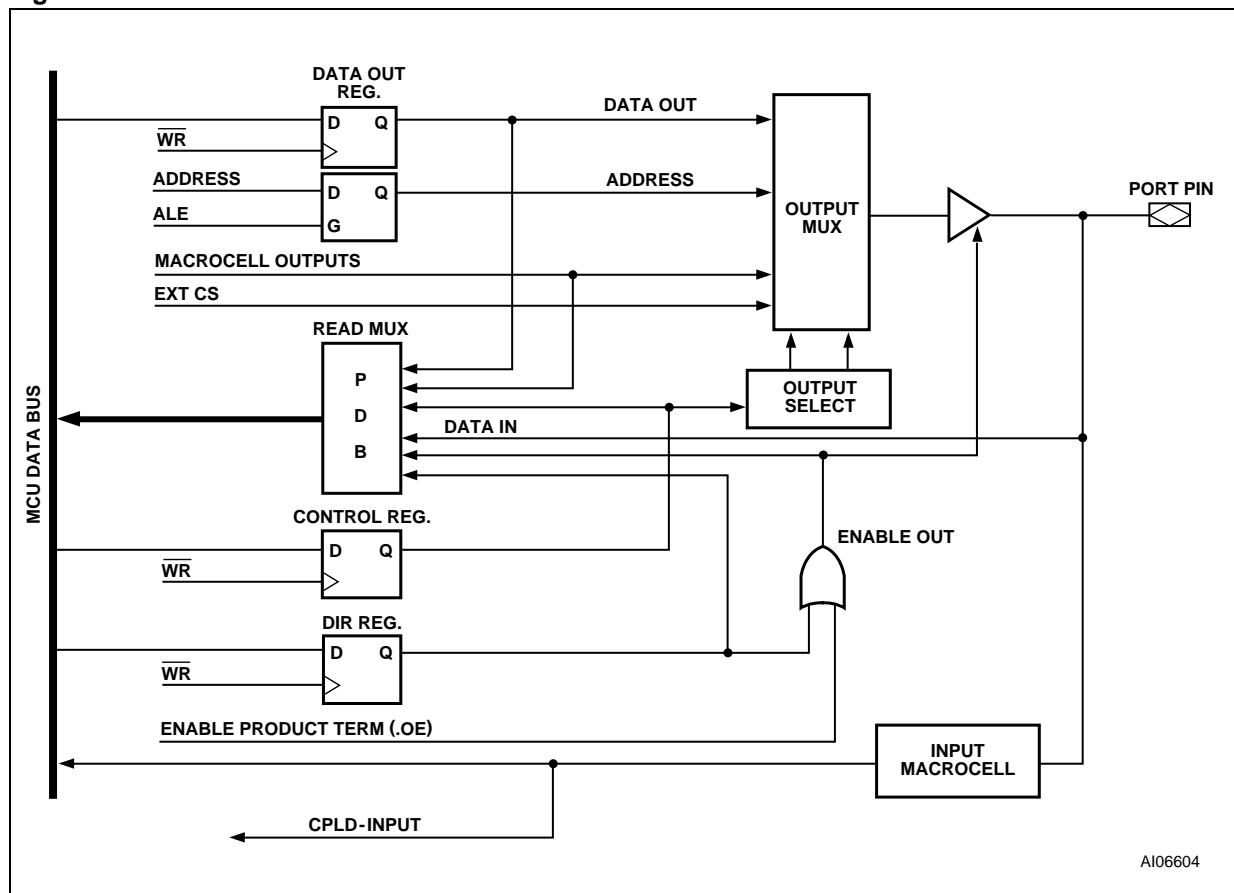

AI06604

The Port pin's tri-state output driver enable is controlled by a two input OR gate whose inputs come from the CPLD AND Array enable product term and the Direction Register. If the enable product term of any of the Array outputs are not defined and that port pin is not defined as a CPLD output in the PSDsoft, then the Direction Register has sole control of the buffer that drives the port pin.

The contents of these registers can be altered by the MCU. The Port Data Buffer (PDB) feedback path allows the MCU to check the contents of the registers.

Ports A, B, and C have embedded Input Macrocells (IMC). The Input Macrocells (IMC) can be configured as latches, registers, or direct inputs to the PLDs. The latches and registers are clocked by Address Strobe (ALE) or a product term from the PLD AND Array. The outputs from the Input Macrocells (IMC) drive the PLD input bus and can be read by the MCU. See the section entitled "Input Macrocell," page 126.

Port Operating Modes

The I/O Ports have several modes of operation. Some modes can be defined using PSDsoft, some by the MCU writing to the Control Registers in CSIOP space, and some by both. The modes that can only be defined using PSDsoft must be programmed into the device and cannot be changed unless the device is reprogrammed. The modes that can be changed by the MCU can be done so dynamically at run-time. The PLD I/O, Data Port, Address Input, and Peripheral I/O Modes are the only modes that must be defined before programming the device. All other modes can be changed by the MCU at run-time. See Application Note AN1171 for more detail.

Table 92 summarizes which modes are available on each port. Table 95 shows how and where the different modes are configured. Each of the port operating modes are described in the following sections.

MCU I/O Mode

In the MCU I/O Mode, the MCU uses the I/O Ports block to expand its own I/O ports. By setting up the CSIOP space, the ports on the PSD MODULE are mapped into the MCU address space. The addresses of the ports are listed in Table 84.

A port pin can be put into MCU I/O Mode by writing a '0' to the corresponding bit in the Control Register. The MCU I/O direction may be changed by writing to the corresponding bit in the Direction Register, or by the output enable product term. See the section entitled "Peripheral I/O Mode," page 128. When the pin is configured as an out-

put, the content of the Data Out Register drives the pin. When configured as an input, the MCU can read the port input through the Data In buffer. See Figure 63, page 127.

Ports C and D do not have Control Registers, and are in MCU I/O Mode by default. They can be used for PLD I/O if equations are written for them in PSDsoft.

PLD I/O Mode

The PLD I/O Mode uses a port as an input to the CPLD's Input Macrocells (IMC), and/or as an output from the CPLD's Output Macrocells (OMC). The output can be tri-stated with a control signal. This output enable control signal can be defined by a product term from the PLD, or by resetting the corresponding bit in the Direction Register to '0.' The corresponding bit in the Direction Register must not be set to '1' if the pin is defined for a PLD input signal in PSDsoft. The PLD I/O Mode is specified in PSDsoft by declaring the port pins, and then writing an equation assigning the PLD I/O to a port.

Address Out Mode

Address Out Mode can be used to drive latched MCU addresses on to the port pins. These port pins can, in turn, drive external devices. Either the output enable or the corresponding bits of both the Direction Register and Control Register must be set to a '1' for pins to use Address Out Mode. This must be done by the MCU at run-time. See Table 94 for the address output pin assignments on Ports A and B for various MCUs.

Peripheral I/O Mode

Peripheral I/O Mode can be used to interface with external peripherals. In this mode, all of Port A serves as a tri-state, bi-directional data buffer for the MCU. Peripheral I/O Mode is enabled by setting Bit 7 of the VM Register to a '1.' Figure 64 shows how Port A acts as a bi-directional buffer for the MCU data bus if Peripheral I/O Mode is enabled. An equation for PSEL0 and/or PSEL1 must be written in PSDsoft. The buffer is tri-stated when PSEL0 or PSEL1 is low (not active). The PSEN signal should be "ANDed" in the PSEL equations to disable the buffer when PSEL resides in the data space.

JTAG In-System Programming (ISP)

Port C is JTAG compliant, and can be used for In-System Programming (ISP). For more information on the JTAG Port, see the section entitled "PROGRAMMING IN-CIRCUIT USING THE JTAG SERIAL INTERFACE," page 142.

Figure 64. Peripheral I/O Mode

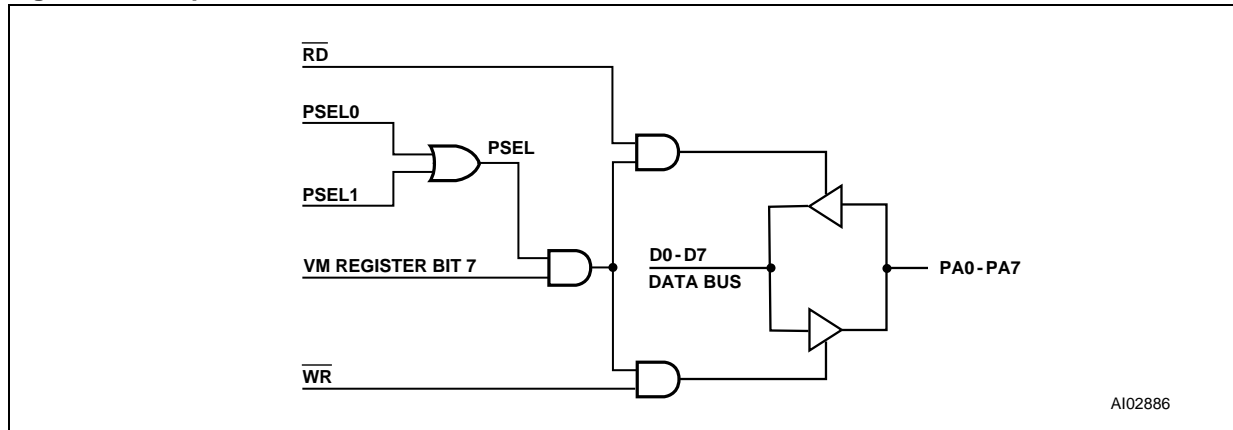

AI02886

Table 92. Port Operating Modes

Port Mode	Port A ²	Port B	Port C	Port D
MCU I/O	Yes	Yes	Yes	Yes
PLD I/O				
McellAB Outputs	Yes	Yes	No	No
McellBC Outputs	No	Yes	Yes	No
Additional Ext. CS Outputs	No	No	No	Yes
PLD Inputs	Yes	Yes	Yes	Yes
Address Out	Yes (A7 – 0)	Yes (A7 – 0)	No	No
Peripheral I/O	Yes	No	No	No
JTAG ISP	No	No	Yes ¹	No

Note: 1. JTAG pins (TMS, TCK, TDI, TDO) are dedicated pins.
 2. Port A is not available in the 52-pin package.

Table 93. Port Operating Mode Settings

Mode	Defined in PSDsoft	Control Register Setting	Direction Register Setting	VM Register Setting
MCU I/O	Declare pins only	0	1 = output, 0 = input (Note ²)	N/A
PLD I/O	Logic equations	N/A	(Note ²)	N/A
Address Out (Port A,B)	Declare pins only	1	1 (Note ²)	N/A
Peripheral I/O (Port A)	Logic equations (PSEL0 & 1)	N/A	N/A	PIO Bit = 1

Note: 1. N/A = Not Applicable
 2. The direction of the Port A,B,C, and D pins are controlled by the Direction Register ORed with the individual output enable product term (.oe) from the CPLD AND Array.

Table 94. I/O Port Latched Address Output Assignments

Port A (PA3-PA0)	Port A (PA7-PA4)	Port B (PB3-PB0)	Port B (PB7-PB4)
Address a3-a0	Address a7-a4	Address a3-a0	Address a7-a4

Port Configuration Registers (PCR)

Each Port has a set of Port Configuration Registers (PCR) used for configuration. The contents of the registers can be accessed by the MCU through normal READ/WRITE bus cycles at the addresses given in Table 84. The addresses in Table 84 are the offsets in hexadecimal from the base of the CSIOP register.

The pins of a port are individually configurable and each bit in the register controls its respective pin. For example, Bit 0 in a register refers to Bit 0 of its port. The three Port Configuration Registers (PCR), shown in Table 95, are used for setting the Port configurations. The default Power-up state for each register in Table 95 is 00h.

Control Register. Any bit reset to '0' in the Control Register sets the corresponding port pin to MCU I/O Mode, and a '1' sets it to Address Out Mode. The default mode is MCU I/O. Only Ports A and B have an associated Control Register.

Direction Register. The Direction Register, in conjunction with the output enable (except for Port D), controls the direction of data flow in the I/O Ports. Any bit set to '1' in the Direction Register causes the corresponding pin to be an output, and any bit set to '0' causes it to be an input. The default mode for all port pins is input.

Figure 65, page 132 and Figure 66, page 133 show the Port Architecture diagrams for Ports A/B and C, respectively. The direction of data flow for Ports A, B, and C are controlled not only by the direction register, but also by the output enable product term from the PLD AND Array. If the output enable product term is not active, the Direction Register has sole control of a given pin's direction.

An example of a configuration for a Port with the three least significant bits set to output and the remainder set to input is shown in Table 98. Since Port D only contains two pins (shown in Figure 68), the Direction Register for Port D has only two bits active.

Drive Select Register. The Drive Select Register configures the pin driver as Open Drain or CMOS for some port pins, and controls the slew rate for the other port pins. An external pull-up resistor should be used for pins configured as Open Drain. A pin can be configured as Open Drain if its corresponding bit in the Drive Select Register is set to a '1.' The default pin drive is CMOS.

Note: The slew rate is a measurement of the rise and fall times of an output. A higher slew rate means a faster output response and may create more electrical noise. A pin operates in a high slew rate when the corresponding bit in the Drive Register is set to '1.' The default rate is slow slew.

Table 99, page 131 shows the Drive Register for Ports A, B, C, and D. It summarizes which pins can be configured as Open Drain outputs and which pins the slew rate can be set for.

Table 95. Port Configuration Registers (PCR)

Register Name	Port	MCU Access
Control	A,B	WRITE/READ
Direction	A,B,C,D	WRITE/READ
Drive Select ¹	A,B,C,D	WRITE/READ

Note: 1. See Table 99 for Drive Register Bit definition.

Table 96. Port Pin Direction Control, Output Enable P.T. Not Defined

Direction Register Bit	Port Pin Mode
0	Input
1	Output

Table 97. Port Pin Direction Control, Output Enable P.T. Defined

Direction Register Bit	Output Enable P.T.	Port Pin Mode
0	0	Input
0	1	Output
1	0	Output
1	1	Output

Table 98. Port Direction Assignment Example

Bit 7	Bit 6	Bit 5	Bit 4	Bit 3	Bit 2	Bit 1	Bit 0
0	0	0	0	0	1	1	1

Port Data Registers

The Port Data Registers, shown in Table 100, are used by the MCU to write data to or read data from the ports. Table 100 shows the register name, the ports having each register type, and MCU access for each register type. The registers are described below.

Data In. Port pins are connected directly to the Data In buffer. In MCU I/O Input Mode, the pin input is read through the Data In buffer.

Data Out Register. Stores output data written by the MCU in the MCU I/O Output Mode. The contents of the Register are driven out to the pins if the Direction Register or the output enable product term is set to '1.' The contents of the register can also be read back by the MCU.

Output Macrocells (OMC). The CPLD Output Macrocells (OMC) occupy a location in the MCU's address space. The MCU can read the output of the Output Macrocells (OMC). If the OMC Mask

Register Bits are not set, writing to the macrocell loads data to the macrocell flip-flops. See the section entitled "PLDs," page 120.

OMC Mask Register. Each OMC Mask Register Bit corresponds to an Output Macrocell (OMC) flip-flop. When the OMC Mask Register Bit is set to a '1,' loading data into the Output Macrocell (OMC) flip-flop is blocked. The default value is '0' or unblocked.

Input Macrocells (IMC). The Input Macrocells (IMC) can be used to latch or store external inputs. The outputs of the Input Macrocells (IMC) are routed to the PLD input bus, and can be read by the MCU. See the section entitled "PLDs," page 120.

Enable Out. The Enable Out register can be read by the MCU. It contains the output enable values for a given port. A '1' indicates the driver is in output mode. A '0' indicates the driver is in tri-state and the pin is in input mode.

Table 99. Drive Register Pin Assignment

Drive Register	Bit 7	Bit 6	Bit 5	Bit 4	Bit 3	Bit 2	Bit 1	Bit 0
Port A	Open Drain	Open Drain	Open Drain	Open Drain	Slew Rate	Slew Rate	Slew Rate	Slew Rate
Port B	Open Drain	Open Drain	Open Drain	Open Drain	Slew Rate	Slew Rate	Slew Rate	Slew Rate
Port C	Open Drain	Open Drain	Open Drain	Open Drain	Open Drain	Open Drain	Open Drain	Open Drain
Port D	NA ¹	NA ¹	NA ¹	NA ¹	NA ¹	Slew Rate	Slew Rate	NA ¹

Note: 1. NA = Not Applicable.

Table 100. Port Data Registers

Register Name	Port	MCU Access
Data In	A,B,C,D	READ – input on pin
Data Out	A,B,C,D	WRITE/READ
Output Macrocell	A,B,C	READ – outputs of macrocells WRITE – loading macrocells flip-flop
Mask Macrocell	A,B,C	WRITE/READ – prevents loading into a given macrocell
Input Macrocell	A,B,C	READ – outputs of the Input Macrocells
Enable Out	A,B,C	READ – the output enable control of the port driver

Ports A and B – Functionality and Structure

Ports A and B have similar functionality and structure, as shown in Figure 65. The two ports can be configured to perform one or more of the following functions:

- MCU I/O Mode
- CPLD Output – Macrocells McellIAB7-McellIAB0 can be connected to Port A or Port B. McellIBC7-McellIBC0 can be connected to Port B or Port C.
- CPLD Input – Via the Input Macrocells (IMC).
- Latched Address output – Provide latched address output as per Table 94.
- Open Drain/Slew Rate – pins PA3-PA0 and PB3-PB0 can be configured to fast slew rate, pins PA7-PA4 and PB7-PB4 can be configured to Open Drain Mode.
- Peripheral Mode – Port A only (80-pin package)

Figure 65. Port A and Port B Structure

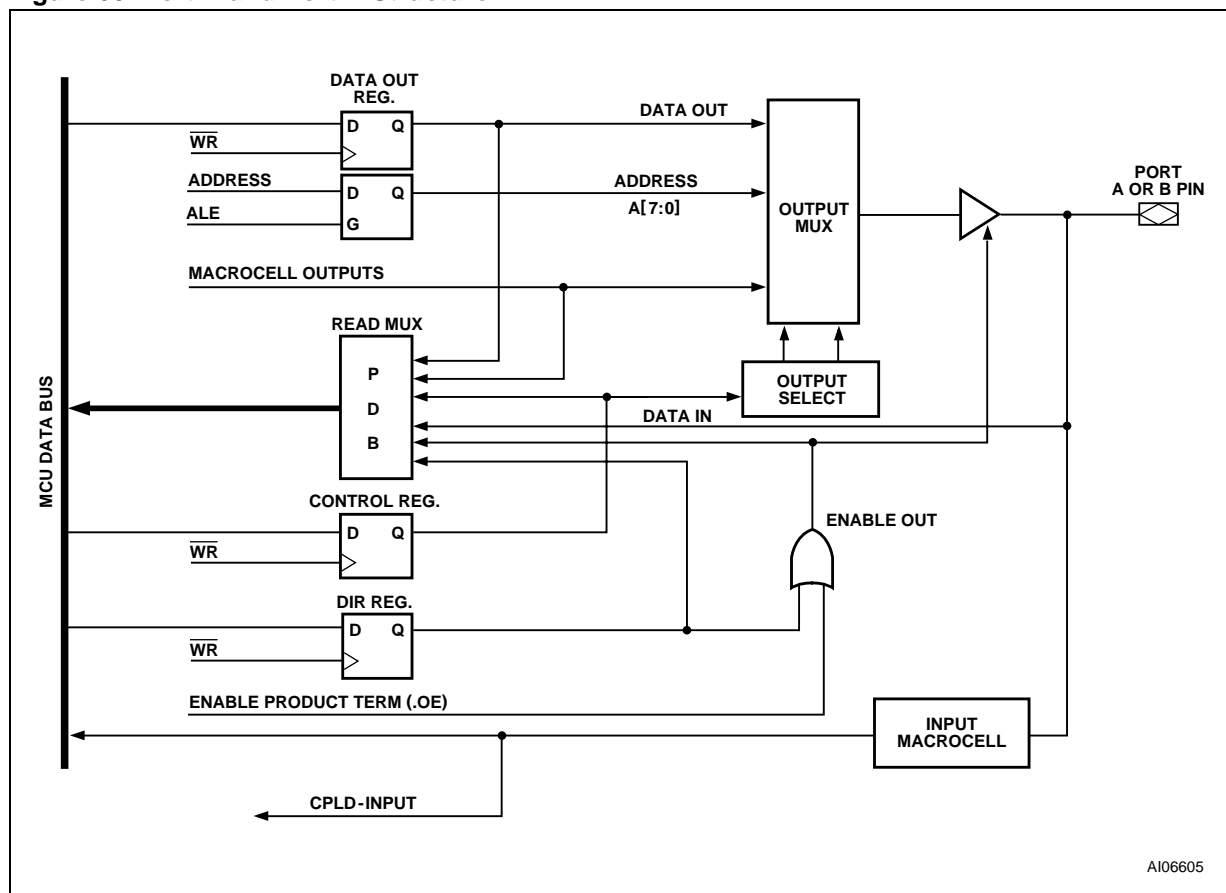

Port C – Functionality and Structure

Port C can be configured to perform one or more of the following functions (see Figure 66):

- MCU I/O Mode
- CPLD Output – McellIBC7-McellIBC0 outputs can be connected to Port B or Port C.
- CPLD Input – via the Input Macrocells (IMC)
- In-System Programming (ISP) – JTAG pins (TMS, TCK, TDI, TDO) are dedicated pins for device programming. (See the section entitled “PROGRAMMING IN-CIRCUIT USING THE

JTAG SERIAL INTERFACE,” page 142, for more information on JTAG programming.)

- Open Drain – Port C pins can be configured in Open Drain Mode
- Battery Backup features – PC2 can be configured for a battery input supply, Voltage Stand-by (V_{STBY}).

PC4 can be configured as a Battery-on Indicator (V_{BATON}), indicating when V_{CC} is less than V_{BAT} .

Port C does not support Address Out Mode, and therefore no Control Register is required.

Figure 66. Port C Structure

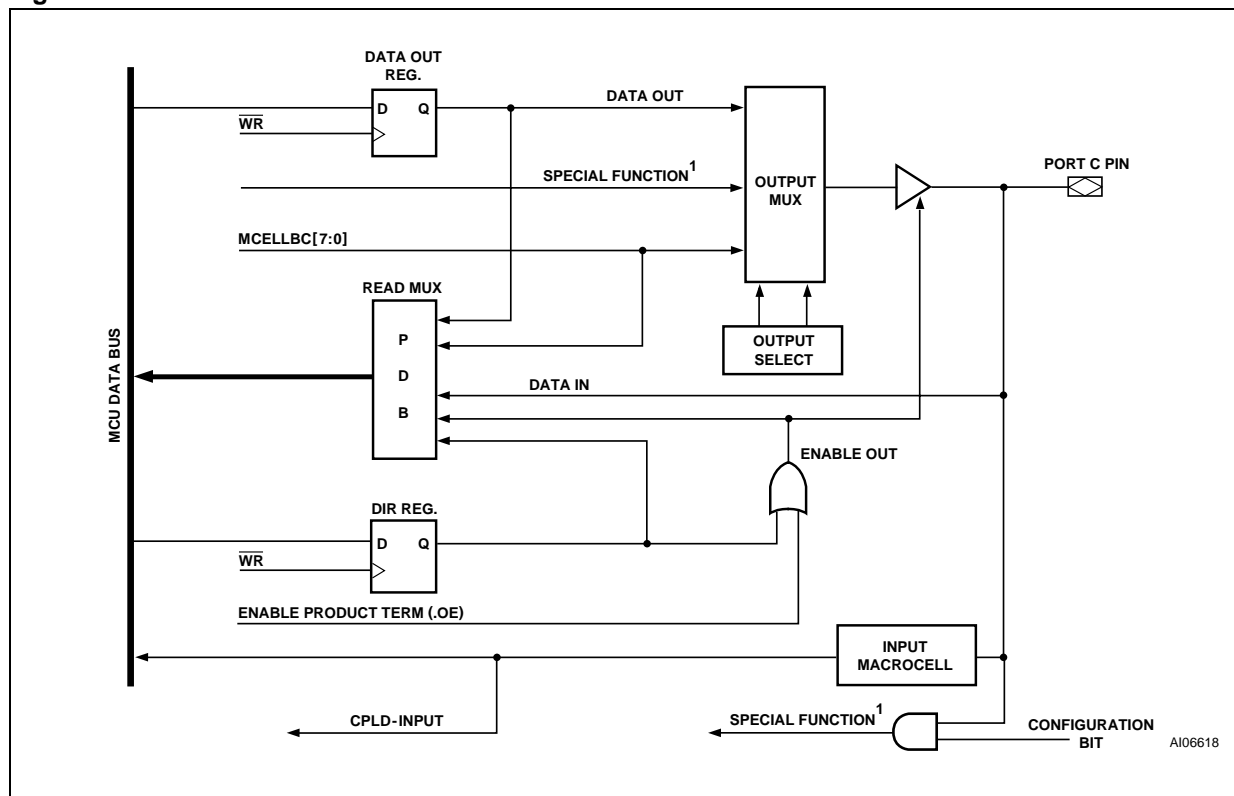

Note: 1. ISP or battery back-up

Port D – Functionality and Structure

Port D has two I/O pins (only one pin, PD1, in the 52-pin package). See Figure 67 and Figure 68. This port does not support Address Out Mode, and therefore no Control Register is required. Of the eight bits in the Port D registers, only Bits 2 and 1 are used to configure pins PD2 and PD1.

Port D can be configured to perform one or more of the following functions:

- MCU I/O Mode
- CPLD Output – External Chip Select (ECS1-ECS2)

- CPLD Input – direct input to the CPLD, no Input Macrocells (IMC)

- Slew rate – pins can be set up for fast slew rate

Port D pins can be configured in PSDsoft Express as input pins for other dedicated functions:

- CLKIN (PD1) as input to the macrocells flip-flops and APD counter
- PSD Chip Select Input (\overline{CSI} , PD2). Driving this signal High disables the Flash memory, SRAM and CSiop.

Figure 67. Port D Structure

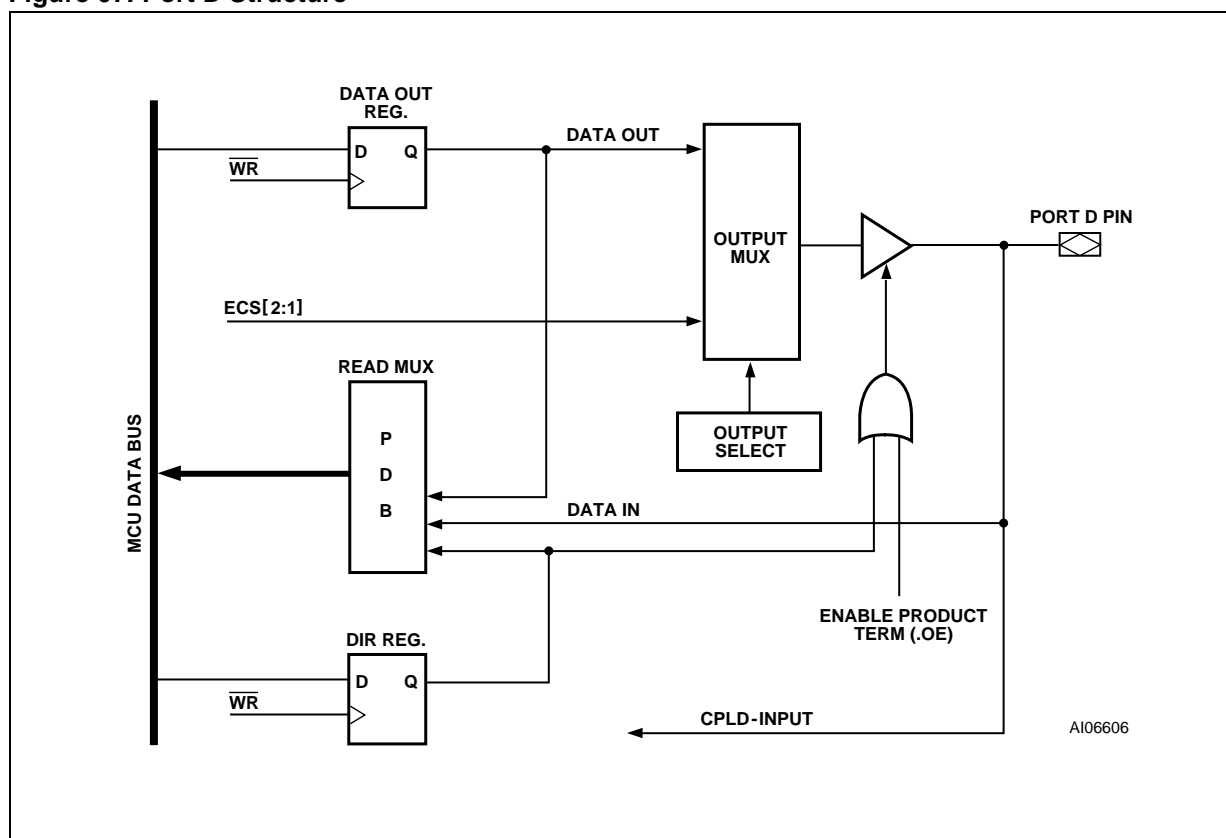

External Chip Select

The CPLD also provides two External Chip Select (ECS1-ECS2) outputs on Port D pins that can be used to select external devices. Each External Chip Select (ECS1-ECS2) consists of one product

term that can be configured active High or Low. The output enable of the pin is controlled by either the output enable product term or the Direction Register. (See Figure 68.)

Figure 68. Port D External Chip Select Signals

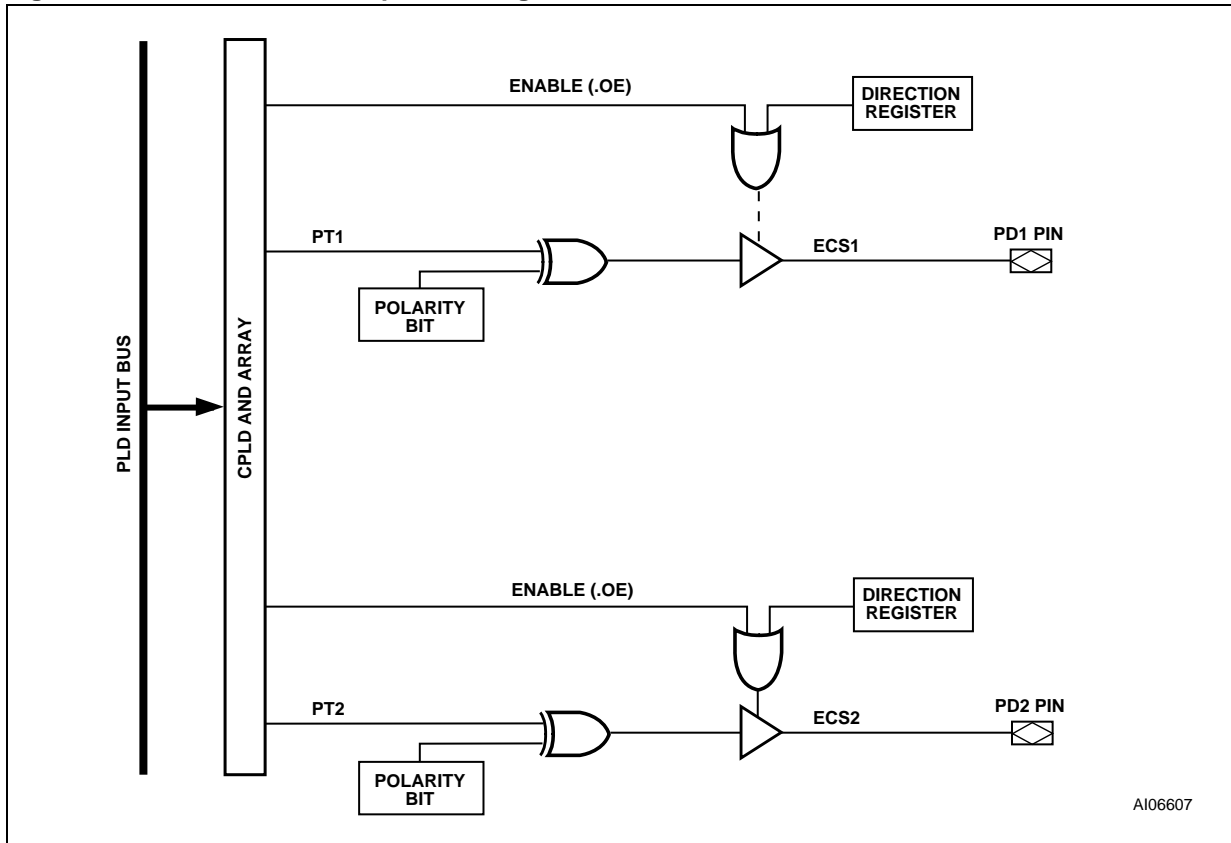

POWER MANAGEMENT

All PSD MODULE offers configurable power saving options. These options may be used individually or in combinations, as follows:

- The primary and secondary Flash memory, and SRAM blocks are built with power management technology. In addition to using special silicon design methodology, power management technology puts the memories into Standby Mode when address/data inputs are not changing (zero DC current). As soon as a transition occurs on an input, the affected memory “wakes up,” changes and latches its outputs, then goes back to standby. The designer does *not* have to do anything special to achieve Memory Standby Mode when no inputs are changing—it happens automatically.

The PLD sections can also achieve Standby Mode when its inputs are not changing, as described in the sections on the Power Management Mode Registers (PMMR).

- As with the Power Management Mode, the Automatic Power Down (APD) block allows the PSD MODULE to reduce to stand-by current automatically. The APD Unit can also block MCU address/data signals from reaching the memories and PLDs. The APD Unit is described in more detail in the sections entitled “The PSD MODULE has a Turbo Bit in PMMR0. This bit can be set to turn the Turbo Mode off (the default is with Turbo Mode turned on). While Turbo Mode is off, the PLDs can achieve standby current when no PLD inputs are changing (zero DC current). Even when inputs do change, significant power can be saved at lower frequencies (AC current), compared to when Turbo Mode is on. When the Turbo Mode is on, there is a significant DC current

component and the AC component is higher...,” page 137.

Built in logic monitors the Address Strobe of the MCU for activity. If there is no activity for a certain time period (MCU is asleep), the APD Unit initiates Power-down Mode (if enabled). Once in Power-down Mode, all address/data signals are blocked from reaching memory and PLDs, and the memories are deselected internally. This allows the memory and PLDs to remain in Standby Mode even if the address/data signals are changing state externally (noise, other devices on the MCU bus, etc.). Keep in mind that any unblocked PLD input signals that are changing states keeps the PLD out of Stand-by Mode, but not the memories.

- PSD Chip Select Input (\overline{CSI} , PD2) can be used to disable the internal memories, placing them in Standby Mode even if inputs are changing. This feature does not block any internal signals or disable the PLDs. This is a good alternative to using the APD Unit. There is a slight penalty in memory access time when PSD Chip Select Input (\overline{CSI} , PD2) makes its initial transition from deselected to selected.
- The PMMRs can be written by the MCU at runtime to manage power. The PSD MODULE supports “blocking bits” in these registers that are set to block designated signals from reaching both PLDs. Current consumption of the PLDs is directly related to the composite frequency of the changes on their inputs (see Figure 72 and Figure 73). Significant power savings can be achieved by blocking signals that are not used in DPLD or CPLD logic equations.

Figure 69. APD Unit

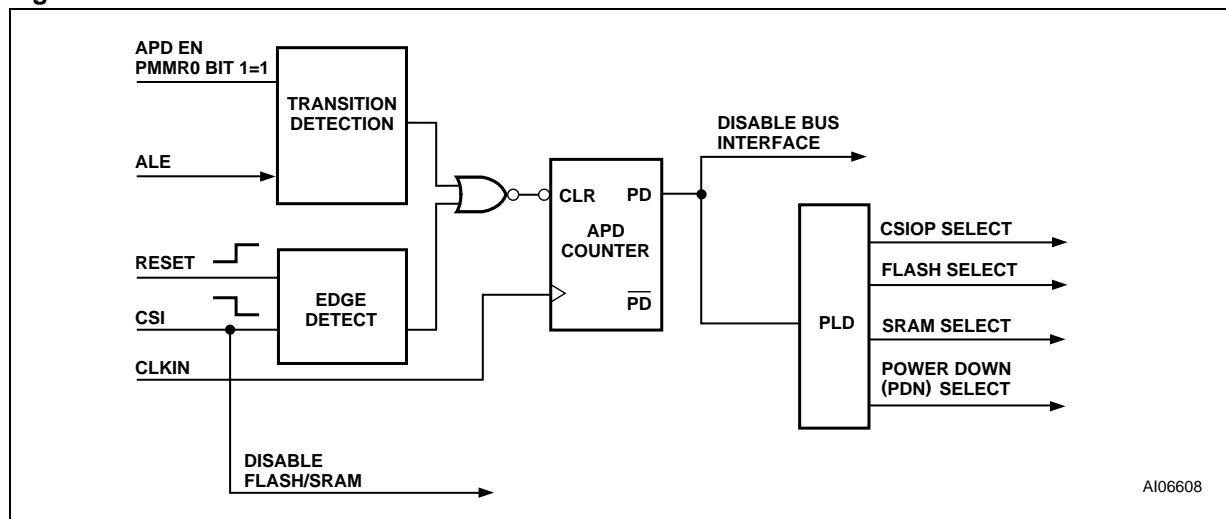

AI06608

The PSD MODULE has a Turbo Bit in PMMR0. This bit can be set to turn the Turbo Mode off (the default is with Turbo Mode turned on). While Turbo Mode is off, the PLDs can achieve standby current when no PLD inputs are changing (zero DC current). Even when inputs do change, significant power can be saved at lower frequencies (AC current), compared to when Turbo Mode is on. When the Turbo Mode is on, there is a significant DC current component and the AC component is higher.

Automatic Power-down (APD) Unit and Power-down Mode. The APD Unit, shown in Figure 69, puts the PSD MODULE into Power-down Mode by monitoring the activity of Address Strobe (ALE). If the APD Unit is enabled, as soon as activity on Address Strobe (ALE) stops, a four-bit counter starts counting. If Address Strobe (ALE/AS, PD0) remains inactive for fifteen clock periods of CLKIN (PD1), Power-down (PDN) goes High, and the PSD MODULE enters Power-down Mode, as discussed next.

Power-down Mode. By default, if you enable the APD Unit, Power-down Mode is automatically enabled. The device enters Power-down Mode if Address Strobe (ALE) remains inactive for fifteen periods of CLKIN (PD1).

The following should be kept in mind when the PSD MODULE is in Power-down Mode:

- If Address Strobe (ALE) starts pulsing again, the PSD MODULE returns to normal Operating mode. The PSD MODULE also returns to normal Operating mode if either PSD Chip Select Input ($\overline{\text{CSI}}$, PD2) is Low or the $\overline{\text{RESET}}$ input is High.
- The MCU address/data bus is blocked from all memory and PLDs.
- Various signals can be blocked (prior to Power-down Mode) from entering the PLDs by setting the appropriate bits in the PMMR registers. The blocked signals include MCU control signals and the common CLKIN (PD1).

Note: Blocking CLKIN (PD1) from the PLDs does not block CLKIN (PD1) from the APD Unit.

- All memories enter Standby Mode and are drawing standby current. However, the PLD and I/O ports blocks do *not* go into Standby Mode because you don't want to have to wait for the logic and I/O to "wake-up" before their outputs

can change. See Table 101 for Power-down Mode effects on PSD MODULE ports.

- Typical standby current is of the order of microamperes. These standby current values assume that there are no transitions on any PLD input.

Other Power Saving Options. The PSD MODULE offers other reduced power saving options that are independent of the Power-down Mode. Except for the SRAM Stand-by and PSD Chip Select Input ($\overline{\text{CSI}}$, PD2) features, they are enabled by setting bits in PMMR0 and PMMR2.

Figure 70. Enable Power-down Flow Chart

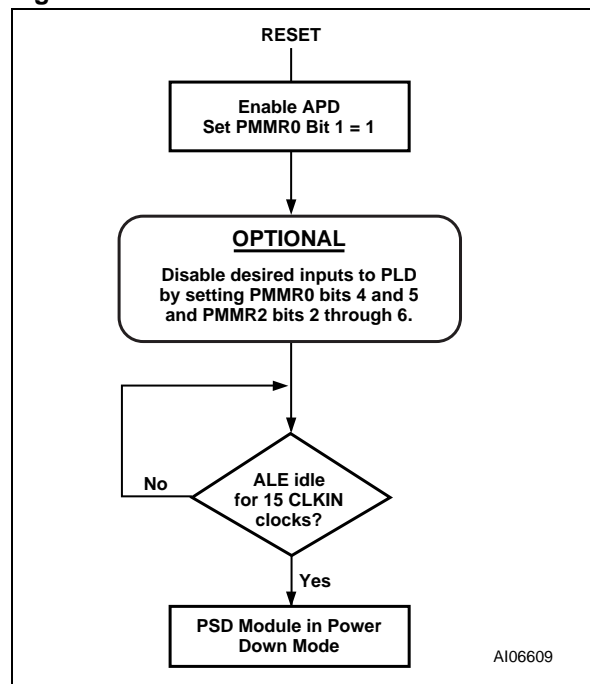

Table 101. Power-down Mode's Effect on Ports

Port Function	Pin Level
MCU I/O	No Change
PLD Out	No Change
Address Out	Undefined
Peripheral I/O	Tri-State

PLD Power Management

The power and speed of the PLDs are controlled by the Turbo Bit (Bit 3) in PMMR0. By setting the bit to '1,' the Turbo Mode is off and the PLDs consume the specified stand-by current when the inputs are not switching for an extended time of 70ns. The propagation delay time is increased by 10ns (for a 5V device) after the Turbo Bit is set to '1' (turned off) when the inputs change at a composite frequency of less than 15MHz. When the Turbo Bit is reset to '0' (turned on), the PLDs run at full power and speed. The Turbo Bit affects the PLD's DC power, AC power, and propagation delay. When the Turbo Mode is off, the μPSD325X devices' input clock frequency is reduced by 5MHz from the maximum rated clock frequency.

Blocking MCU control signals with the bits of PMMR2 can further reduce PLD AC power consumption.

SRAM Standby Mode (Battery Backup). The SRAM in the PSD MODULE supports a battery backup mode in which the contents are retained in the event of a power loss. The SRAM has Voltage Stand-by (V_{STBY} , PC2) that can be connected to an external battery. When V_{CC} becomes lower than V_{STBY} then the SRAM automatically connects to Voltage Stand-by (V_{STBY} , PC2) as a power source. The SRAM Standby Current (I_{STBY}) is typically 0.5 μA. The SRAM data retention voltage is 2V minimum. The Battery-on Indicator (V_{BATON}) can be routed to PC4. This signal indicates when the V_{CC} has dropped below V_{STBY} .

PSD Chip Select Input (\overline{CSI} , PD2)

PD2 of Port D can be configured in PSDsoft Express as PSD Chip Select Input (\overline{CSI}). When Low, the signal selects and enables the PSD MODULE Flash memory, SRAM, and I/O blocks for READ or WRITE operations. A High on PSD Chip Select Input (\overline{CSI} , PD2) disables the Flash memory, and SRAM, and reduces power consumption. However, the PLD and I/O signals remain operational when PSD Chip Select Input (\overline{CSI} , PD2) is High.

Input Clock

CLKIN (PD1) can be turned off, to the PLD to save AC power consumption. CLKIN (PD1) is an input to the PLD AND Array and the Output Macrocells (OMC).

During Power-down Mode, or, if CLKIN (PD1) is not being used as part of the PLD logic equation, the clock should be disabled to save AC power. CLKIN (PD1) is disconnected from the PLD AND Array or the Macrocells block by setting Bits 4 or 5 to a '1' in PMMR0.

Input Control Signals

The PSD MODULE provides the option to turn off the MCU signals (\overline{WR} , \overline{RD} , \overline{PSEN} , and Address Strobe (ALE)) to the PLD to save AC power consumption. These control signals are inputs to the PLD AND Array. During Power-down Mode, or, if any of them are not being used as part of the PLD logic equation, these control signals should be disabled to save AC power. They are disconnected from the PLD AND Array by setting Bits 2, 3, 4, 5, and 6 to a '1' in PMMR2.

Table 102. Power Management Mode Registers PMMR0¹

Bit 0	X	0	Not used, and should be set to zero.
Bit 1	APD Enable	0 = off	Automatic Power-down (APD) is disabled.
		1 = on	Automatic Power-down (APD) is enabled.
Bit 2	X	0	Not used, and should be set to zero.
Bit 3	PLD Turbo	0 = on	PLD Turbo Mode is on
		1 = off	PLD Turbo Mode is off, saving power. μPSD325X devices operate at 5MHz below the maximum rated clock frequency
Bit 4	PLD Array clk	0 = on	CLKIN (PD1) input to the PLD AND Array is connected. Every change of CLKIN (PD1) Powers-up the PLD when Turbo Bit is '0.'
		1 = off	CLKIN (PD1) input to PLD AND Array is disconnected, saving power.
Bit 5	PLD MCell clk	0 = on	CLKIN (PD1) input to the PLD macrocells is connected.
		1 = off	CLKIN (PD1) input to PLD macrocells is disconnected, saving power.
Bit 6	X	0	Not used, and should be set to zero.
Bit 7	X	0	Not used, and should be set to zero.



Table 103. Power Management Mode Registers PMMR2¹

Bit 0	X	0	Not used, and should be set to zero.
Bit 1	X	0	Not used, and should be set to zero.
Bit 2	PLD Array WR	0 = on	\overline{WR} input to the PLD AND Array is connected.
		1 = off	\overline{WR} input to PLD AND Array is disconnected, saving power.
Bit 3	PLD Array RD	0 = on	\overline{RD} input to the PLD AND Array is connected.
		1 = off	\overline{RD} input to PLD AND Array is disconnected, saving power.
Bit 4	PLD Array PSEN	0 = on	\overline{PSEN} input to the PLD AND Array is connected.
		1 = off	\overline{PSEN} input to PLD AND Array is disconnected, saving power.
Bit 5	PLD Array ALE	0 = on	ALE input to the PLD AND Array is connected.
		1 = off	ALE input to PLD AND Array is disconnected, saving power.
Bit 6	X	0	Not used, and should be set to zero.
Bit 7	X	0	Not used, and should be set to zero.

Note: 1. The bits of this register are cleared to zero following Power-up. Subsequent RESET pulses do not clear the registers.

Table 104. APD Counter Operation

APD Enable Bit	ALE Level	APD Counter
0	X	Not Counting
1	Pulsing	Not Counting
1	0 or 1	Counting (Generates PDN after 15 Clocks)

RESET TIMING AND DEVICE STATUS AT RESET

Upon Power-up, the PSD MODULE requires a Reset (RESET) pulse of duration $t_{NLNH-PO}$ after V_{CC} is steady. During this period, the device loads internal configurations, clears some of the registers and sets the Flash memory into operating mode. After the rising edge of Reset (RESET), the PSD MODULE remains in the Reset Mode for an additional period, t_{OPR} , before the first memory access is allowed.

The Flash memory is reset to the READ Mode upon Power-up. Sector Select (FS0-FS7 and CSBOOT0-CSBOOT3) must all be Low, WRITE Strobe (WR, CNTL0) High, during Power-on RESET for maximum security of the data contents and to remove the possibility of a byte being written on the first edge of WRITE Strobe (WR). Any Flash memory WRITE cycle initiation is prevented automatically when V_{CC} is below V_{LKO} .

Warm RESET

Once the device is up and running, the PSD MODULE can be reset with a pulse of a much shorter duration, t_{NLNH} . The same t_{OPR} period is needed

before the device is operational after a Warm RESET. Figure 71 shows the timing of the Power-up and Warm RESET.

I/O Pin, Register and PLD Status at RESET

Table 105 shows the I/O pin, register and PLD status during Power-on RESET, Warm RESET, and Power-down Mode. PLD outputs are always valid during Warm RESET, and they are valid in Power-on RESET once the internal Configuration bits are loaded. This loading is completed typically long before the V_{CC} ramps up to operating level. Once the PLD is active, the state of the outputs are determined by the PLD equations.

Reset of Flash Memory Erase and Program Cycles

A Reset (RESET) also resets the internal Flash memory state machine. During a Flash memory Program or Erase cycle, Reset (RESET) terminates the cycle and returns the Flash memory to the READ Mode within a period of t_{NLNH-A} .

Figure 71. Reset (RESET) Timing

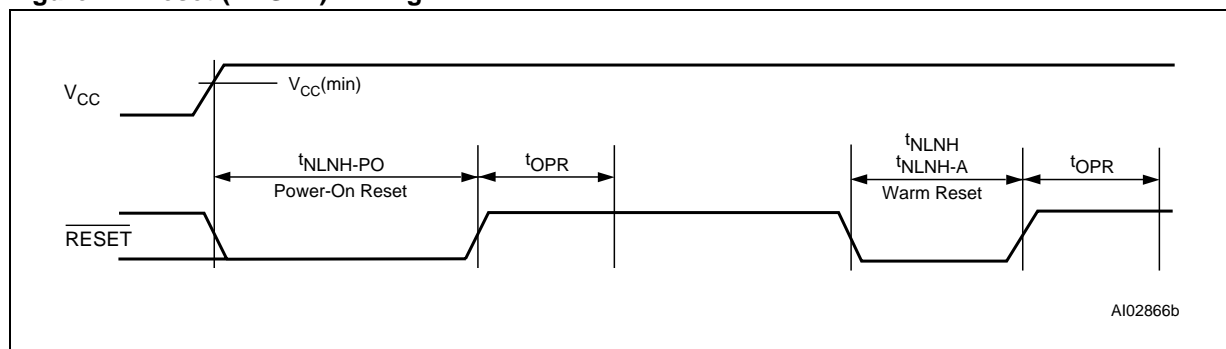

Table 105. Status During Power-on $\overline{\text{RESET}}$, Warm $\overline{\text{RESET}}$ and Power-down Mode

Port Configuration	Power-On $\overline{\text{RESET}}$	Warm $\overline{\text{RESET}}$	Power-down Mode
MCU I/O	Input mode	Input mode	Unchanged
PLD Output	Valid after internal PSD configuration bits are loaded	Valid	Depends on inputs to PLD (addresses are blocked in PD Mode)
Address Out	Tri-stated	Tri-stated	Not defined
Peripheral I/O	Tri-stated	Tri-stated	Tri-stated

Register	Power-On $\overline{\text{RESET}}$	Warm $\overline{\text{RESET}}$	Power-down Mode
PMMR0 and PMMR2	Cleared to '0'	Unchanged	Unchanged
Macrocells flip-flop status	Cleared to '0' by internal Power-on $\overline{\text{RESET}}$	Depends on .re and .pr equations	Depends on .re and .pr equations
VM Register ¹	Initialized, based on the selection in PSDsoft Configuration menu	Initialized, based on the selection in PSDsoft Configuration menu	Unchanged
All other registers	Cleared to '0'	Cleared to '0'	Unchanged

Note: 1. The SR_cod and PeriphMode Bits in the VM Register are always cleared to '0' on Power-on $\overline{\text{RESET}}$ or Warm $\overline{\text{RESET}}$.

PROGRAMMING IN-CIRCUIT USING THE JTAG SERIAL INTERFACE

The JTAG Serial Interface pins (TMS, TCK, TDI, TDO) are dedicated pins on Port C (see Table 106). All memory blocks (primary and secondary Flash memory), PLD logic, and PSD MODULE Configuration Register Bits may be programmed through the JTAG Serial Interface block. A blank device can be mounted on a printed circuit board and programmed using JTAG.

The standard JTAG signals (IEEE 1149.1) are TMS, TCK, TDI, and TDO. Two additional signals, \overline{TSTAT} and \overline{TERR} , are optional JTAG extensions used to speed up Program and Erase cycles.

By default, on a blank device (as shipped from the factory or after erasure), four pins on Port C are the basic JTAG signals TMS, TCK, TDI, and TDO.

Standard JTAG Signals

At power-up, the standard JTAG pins are inputs, waiting for a JTAG serial command from an external JTAG controller device (such as FlashLINK or Automated Test Equipment). When the enabling command is received, TDO becomes an output and the JTAG channel is fully functional. The same command that enables the JTAG channel may optionally enable the two additional JTAG signals, \overline{TSTAT} and \overline{TERR} .

The \overline{RESET} input to the µPS3200 should be active during JTAG programming. The active \overline{RESET} puts the MCU module into RESET Mode while the PSD Module is being programmed. See Application Note AN1153 for more details on JTAG In-System Programming (ISP).

The µPSD325X devices supports JTAG In-System-Configuration (ISC) commands, but not Boundary Scan. The PSDsoft Express software tool and FlashLINK JTAG programming cable implement the JTAG In-System-Configuration (ISC) commands. A definition of these JTAG In-System-Configuration (ISC) commands and sequences is defined in a supplemental document available from ST. This document is needed only as a reference for designers who use a FlashLINK to program the µPSD325X devices.

Table 106. JTAG Port Signals

Port C Pin	JTAG Signals	Description
PC0	TMS	Mode Select
PC1	TCK	Clock
PC3	\overline{TSTAT}	Status (optional)
PC4	\overline{TERR}	Error Flag (optional)
PC5	TDI	Serial Data In
PC6	TDO	Serial Data Out

JTAG Extensions

\overline{TSTAT} and \overline{TERR} are two JTAG extension signals enabled by an "ISC_ENABLE" command received over the four standard JTAG signals (TMS, TCK, TDI, and TDO). They are used to speed Program and Erase cycles by indicating status on µPDS signals instead of having to scan the status out serially using the standard JTAG channel. See Application Note AN1153.

\overline{TERR} indicates if an error has occurred when erasing a sector or programming a byte in Flash memory. This signal goes Low (active) when an Error condition occurs, and stays Low until an "ISC_CLEAR" command is executed or a chip Reset (\overline{RESET}) pulse is received after an "ISC_DISABLE" command.

\overline{TSTAT} behaves the same as Ready/Busy described in the section entitled "Ready/Busy (PC3)," page 107. \overline{TSTAT} is High when the PSD MODULE device is in READ Mode (primary and secondary Flash memory contents can be read). \overline{TSTAT} is Low when Flash memory Program or Erase cycles are in progress, and also when data is being written to the secondary Flash memory.

\overline{TSTAT} and \overline{TERR} can be configured as open-drain type signals during an "ISC_ENABLE" command.

Security and Flash memory Protection

When the Security Bit is set, the device cannot be read on a Device Programmer or through the JTAG Port. When using the JTAG Port, only a Full Chip Erase command is allowed.

All other Program, Erase and Verify commands are blocked. Full Chip Erase returns the part to a non-secured blank state. The Security Bit can be set in PSDsoft Express Configuration.

All primary and secondary Flash memory sectors can individually be sector protected against erasures. The sector protect bits can be set in PSDsoft Express Configuration.

INITIAL DELIVERY STATE

When delivered from ST, the µPSD325X devices have all bits in the memory and PLDs set to '1.' The code, configuration, and PLD logic are loaded using the programming procedure. Information for programming the device is available directly from ST. Please contact your local sales representative.



AC/DC PARAMETERS

These tables describe the AD and DC parameters of the μPSD325X devices:

→ DC Electrical Specification

→ AC Timing Specification

■ PLD Timing

- Combinatorial Timing
- Synchronous Clock Mode
- Asynchronous Clock Mode
- Input Macrocell Timing

■ MCU Module Timing

- READ Timing
- WRITE Timing

- Power-down and $\overline{\text{RESET}}$ Timing

The following are issues concerning the parameters presented:

- In the DC specification the supply current is given for different modes of operation.
- The AC power component gives the PLD, Flash memory, and SRAM mA/MHz specification. Figure 72 and Figure 73 show the PLD mA/MHz as a function of the number of Product Terms (PT) used.
- In the PLD timing parameters, add the required delay when Turbo Bit is '0.'

Figure 72. PLD I_{CC} /Frequency Consumption (5V range)

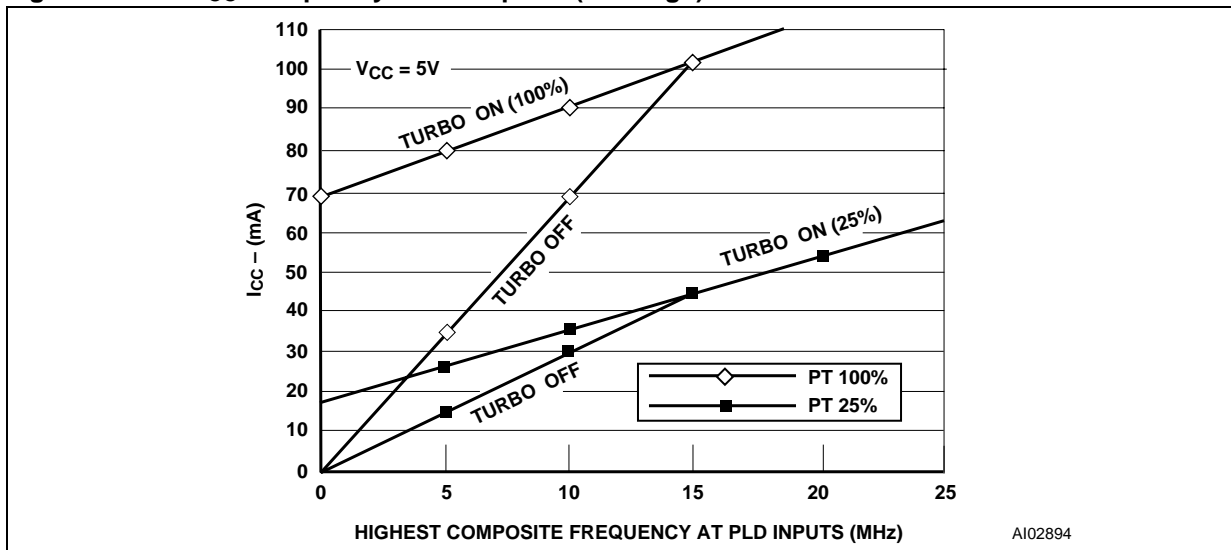
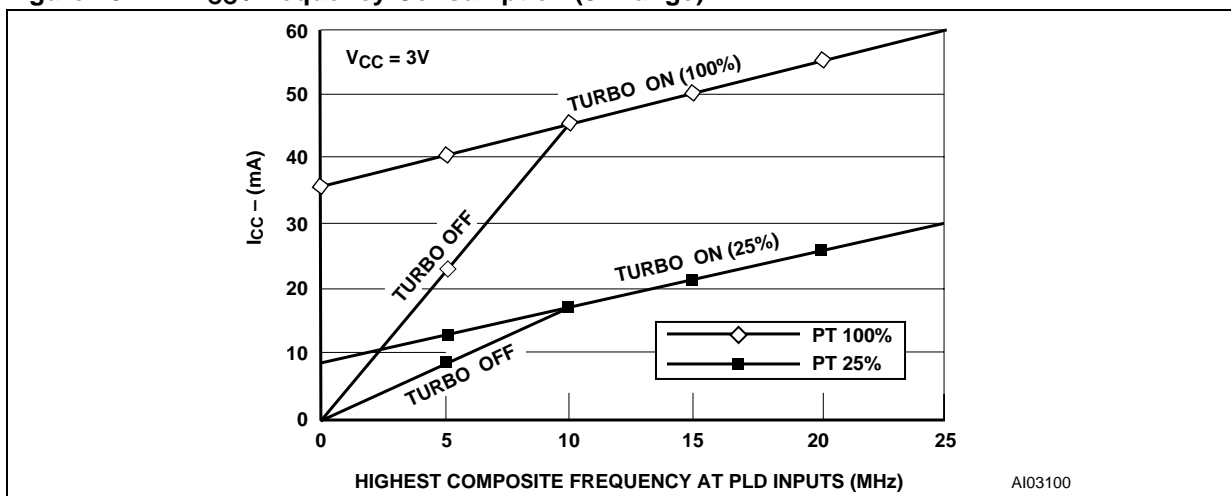

Figure 73. PLD I_{CC} /Frequency Consumption (3V range)



μPSD325X DEVICES

Table 107. PSD MODULE Example, Typ. Power Calculation at V_{CC} = 5.0V (Turbo Mode Off)

Conditions	
MCU Clock Frequency	= 12MHz
Highest Composite PLD input frequency (Freq PLD)	= 8MHz
MCU ALE frequency (Freq ALE)	= 2MHz
% Flash memory Access	= 80%
% SRAM access	= 15%
% I/O access	= 5% (no additional power above base)
Operational Modes	
% Normal	= 40%
% Power-down Mode	= 60%
Number of product terms used	
(from fitter report)	= 45 PT
% of total product terms	= 45/182 = 24.7%
Turbo Mode	= Off
Calculation (using typical values)	
I _{CC} total	= I _{CC} (MCUactive) x %MCUactive + I _{CC} (PSDactive) x %PSDactive + I _{PD} (pwrdown) x %pwrdown
I _{CC} (MCUactive)	= 20mA
I _{PD} (pwrdown)	= 250μA
I _{CC} (PSDactive)	= I _{CC} (ac) + I _{CC} (dc)
	= %flash x 2.5 mA/MHz x Freq ALE
	+ %SRAM x 1.5 mA/MHz x Freq ALE
	+ % PLD x (from graph using Freq PLD)
	= 0.8 x 2.5 mA/MHz x 2MHz + 0.15 x 1.5 mA/MHz x 2MHz + 24 mA
	= (4 + 0.45 + 24) mA
	= 28.45mA
I _{CC} total	= 20mA x 40% + 28.45mA x 40% + 250μA x 60%
	= 8mA + 11.38mA + 150μA
	= 19.53mA
This is the operating power with no Flash memory Erase or Program cycles in progress. Calculation is based on all I/O pins being disconnected and I _{OUT} = 0 mA.	

MAXIMUM RATING

Stressing the device above the rating listed in the Absolute Maximum Ratings table may cause permanent damage to the device. These are stress ratings only and operation of the device at these or any other conditions above those indicated in the Operating sections of this specification is not im-

plied. Exposure to Absolute Maximum Rating conditions for extended periods may affect device reliability. Refer also to the STMicroelectronics SURE Program and other relevant quality documents.

Table 108. Absolute Maximum Ratings

Symbol	Parameter	Min.	Max.	Unit
T _{STG}	Storage Temperature	-65	125	°C
T _{LEAD}	Lead Temperature during Soldering (20 seconds max.) ¹		235	°C
V _{IO}	Input and Output Voltage (Q = V _{OH} or Hi-Z)	-0.5	6.5	V
V _{CC}	Supply Voltage	-0.5	6.5	V
V _{PP}	Device Programmer Supply Voltage	-0.5	14.0	V
V _{ESD}	Electrostatic Discharge Voltage (Human Body Model) ²	-2000	2000	V

Note: 1. IPC/JEDEC J-STD-020A

2. JEDEC Std JESD22-A114A (C1=100pF, R1=1500 Ω, R2=500 Ω)

μPSD325X DEVICES

DC AND AC PARAMETERS

This section summarizes the operating and measurement conditions, and the DC and AC characteristics of the device. The parameters in the DC and AC Characteristic tables that follow are derived from tests performed under the Measure-

ment Conditions summarized in the relevant tables. Designers should check that the operating conditions in their circuit match the measurement conditions when relying on the quoted parameters.

Table 109. Operating Conditions (5V Devices)

Symbol	Parameter	Min.	Max.	Unit
V _{CC}	Supply Voltage	4.5	5.5	V
T _A	Ambient Operating Temperature (industrial)	-40	85	°C
	Ambient Operating Temperature (commercial)	0	70	°C

Table 110. Operating Conditions (3V Devices)

Symbol	Parameter	Min.	Max.	Unit
V _{CC}	Supply Voltage	3.0	3.6	V
T _A	Ambient Operating Temperature (industrial)	-40	85	°C
	Ambient Operating Temperature (commercial)	0	70	°C

Table 111. AC Symbols for Timing

Signal Letters	
A	Address
C	Clock
D	Input Data
I	Instruction
L	ALE
N	$\overline{\text{RESET}}$ Input or Output
P	$\overline{\text{PSEN}}$ signal
Q	Output Data
R	RD signal
W	WR signal
B	V _{STBY} Output
M	Output Macrocell

Signal Behavior	
t	Time
L	Logic Level Low or ALE
H	Logic Level High
V	Valid
X	No Longer a Valid Logic Level
Z	Float
PW	Pulse Width

Example: t_{AVLX} – Time from Address Valid to ALE Invalid.

Figure 74. Switching Waveforms – Key

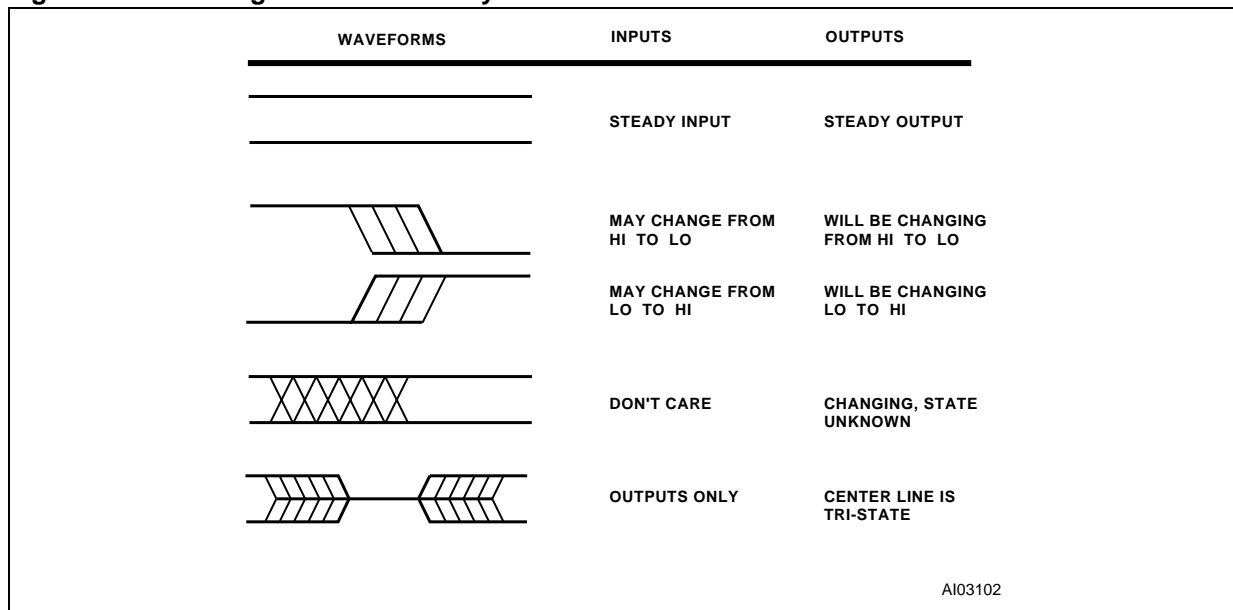

μPSD325X DEVICES

Table 112. DC Characteristics (5V Devices)

Symbol	Parameter	Test Condition (in addition to those in Table 109, page 146)	Min.	Typ.	Max.	Unit
V _{IH}	Input High Voltage (Ports 1, 2, 3, 4[Bits 7,6,5,4,3,1,0], XTAL1, RESET)	4.5V < V _{CC} < 5.5V	0.7V _{CC}		V _{CC} + 0.5	V
V _{IH1}	Input High Voltage (Ports A, B, C, D, 4[Bit 2], USB+, USB-)	4.5V < V _{CC} < 5.5V	2.0		V _{CC} + 0.5	V
V _{IL}	Input Low Voltage (Ports 1, 2, 3, 4[Bits 7,6,5,4,3,1,0], XTAL1, RESET)	4.5V < V _{CC} < 5.5V	V _{SS} - 0.5		0.3V _{CC}	V
V _{IL1}	Input Low Voltage (Ports A, B, C, D, 4[Bit 2])	4.5V < V _{CC} < 5.5V	-0.5		0.8	V
	Input High Voltage (USB+, USB-)	4.5V < V _{CC} < 5.5V	V _{SS} - 0.5		0.8	V
V _{OL}	Output Low Voltage (Ports A,B,C,D)	I _{OL} = 20μA V _{CC} = 4.5V		0.01	0.1	V
		I _{OL} = 8mA V _{CC} = 4.5V		0.25	0.45	V
V _{OL1}	Output Low Voltage (Ports 1,2,3,4, WR, RD)	I _{OL} = 1.6mA			0.45	V
V _{OL2}	Output Low Voltage (Port 0, ALE, PSEN)	I _{OL} = 3.2mA			0.45	V
V _{OH}	Output High Voltage (Ports A,B,C,D)	I _{OH} = -20μA V _{CC} = 4.5V	4.4	4.49		V
		I _{OH} = -2mA V _{CC} = 4.5V	2.4	3.9		V
V _{OH1}	Output High Voltage (Ports 1,2,3,4, WR, RD)	I _{OH} = -80μA	2.4			V
		I _{OH} = -10μA	4.05			V
V _{OH2}	Output High Voltage (Port 0 in ext. Bus Mode, ALE, PSEN)) ⁴	I _{OH} = -800μA	2.4			V
		I _{OH} = -80μA	4.05			V
V _{OH3}	Output High Voltage V _{STBYON}	I _{OH} = -1μA	V _{STBY} - 0.8			V
V _{LVR}	Low Voltage RESET	0.1V hysteresis	3.75	4.0	4.25	V
V _{OP}	XTAL Open Bias Voltage (XTAL1, XTAL2)	I _{OL} = 3.2mA	2.0		3.0	V
V _{LKO}	V _{CC} (min) for Flash Erase and Program		2.5		4.2	V
V _{STBY}	SRAM (PSD) Stand-by Voltage		2.0		V _{CC} -0.2	V
V _{DF}	SRAM (PSD) Data Retention Voltage	Only on V _{STBY}	2			V
I _{IL}	Logic '0' Input Current (Ports 1,2,3,4)	V _{IN} = 0.45V (0V for Port 4[pin 2])	-10		-50	μA
I _{TL}	Logic 1-to-0 Transition Current (Ports 1,2,3,4)	V _{IN} = 3.5V (2.5V for Port 4[pin 2])	-65		-650	μA

Symbol	Parameter	Test Condition (in addition to those in Table 109, page 146)	Min.	Typ.	Max.	Unit	
I _{STBY}	SRAM (PSD) Stand-by Current (V _{STBY} input)	V _{CC} = 0V		0.5	1	μA	
I _{IDLE}	SRAM (PSD) Idle Current (V _{STBY} input)	V _{CC} > V _{STBY}	-0.1		0.1	μA	
I _{RST}	Reset Pin Pull-up Current (RESET)	V _{IN} = V _{SS}	-10		-55	μA	
I _{FR}	XTAL Feedback Resistor Current (XTAL1)	XTAL1 = V _{CC} XTAL2 = V _{SS}	-20		-50	μA	
I _{LI}	Input Leakage Current	V _{SS} < V _{IN} < V _{CC}	-1		1	μA	
I _{LO}	Output Leakage Current	0.45 < V _{OUT} < V _{CC}	-10		10	μA	
I _{PD} ¹	Power-down Mode	V _{CC} = 5.5V LVD logic disabled			250	μA	
		LVD logic enabled			380	μA	
I _{CC_CPU} ^{2,3,6}	Active (12MHz)	V _{CC} = 5V		20	30	mA	
	Idle (12MHz)			8	10	mA	
	Active (24MHz)	V _{CC} = 5V		30	38	mA	
	Idle (24MHz)			15	20	mA	
	Active (40MHz)	V _{CC} = 5V		40	62	mA	
	Idle (40MHz)			20	30	mA	
I _{CC_PSD} (DC) ⁶	Operating Supply Current	PLD Only	PLD_TURBO = Off, f = 0MHz ⁷		0	μA/PT ⁵	
		PLD Only	PLD_TURBO = On, f = 0MHz		400	700	μA/PT
	Flash memory	During Flash memory WRITE/Erase Only			15	30	mA
		Read-only, f = 0MHz			0	0	mA
	SRAM	f = 0MHz			0	0	mA
I _{CC_PSD} (AC) ⁶	PLD AC Base			note ⁵			
	Flash memory AC Adder			2.5	3.5	mA/ MHz	
	SRAM AC Adder			1.5	3.0	mA/ MHz	

- Note: 1. I_{PD} (Power-down Mode) is measured with:
XTAL1=V_{SS}; XTAL2=not connected; RESET=V_{CC}; Port 0=V_{CC}; all other pins are disconnected. PLD not in Turbo Mode.
2. I_{CC_CPU} (active mode) is measured with:
XTAL1 driven with t_{CLCH}, t_{CHCL} = 5ns, V_{IL} = V_{SS}+0.5V, V_{IH} = V_{CC} - 0.5V, XTAL2 = not connected; RESET=V_{SS}; Port 0=V_{CC}; all other pins are disconnected. I_{CC} would be slightly higher if a crystal oscillator is used (approximately 1mA).
3. I_{CC_CPU} (Idle Mode) is measured with:
XTAL1 driven with t_{CLCH}, t_{CHCL} = 5ns, V_{IL} = V_{SS}+0.5V, V_{IH} = V_{CC} - 0.5V, XTAL2 = not connected; Port 0 = V_{CC}; RESET=V_{CC}; all other pins are disconnected.
4. PLD is in non-Turbo Mode and none of the inputs are switching.
5. See Figure 72 for the PLD current calculation.
6. I/O current = 0 mA, all I/O pins are disconnected.

μPSD325X DEVICES

Table 113. DC Characteristics (3V Devices)

Symbol	Parameter	Test Condition (in addition to those in Table 110, page 146)	Min.	Typ.	Max.	Unit
V _{IH}	Input High Voltage (Ports 1, 2, 3, 4[Bits 7,6,5,4,3,1,0], A, B, C, D, XTAL1, RESET)	3.0V < V _{CC} < 3.6V	0.7V _{CC}		V _{CC} + 0.5	V
V _{IH1}	Input High Voltage (Port 4[Bit 2])	3.0V < V _{CC} < 3.6V	2.0		V _{CC} + 0.5	V
V _{IL}	Input High Voltage (Ports 1, 2, 3, 4[Bits 7,6,5,4,3,1,0], XTAL1, RESET)	3.0V < V _{CC} < 3.6V	V _{SS} - 0.5		0.3V _{CC}	V
V _{IL1}	Input Low Voltage (Ports A, B, C, D)	3.0V < V _{CC} < 3.6V	-0.5		0.8	V
	Input Low Voltage (Port 4[Bit 2])	3.0V < V _{CC} < 3.6V	V _{SS} - 0.5		0.8	V
V _{OL}	Output Low Voltage (Ports A,B,C,D)	I _{OL} = 20μA V _{CC} = 3.0V		0.01	0.1	V
		I _{OL} = 4mA V _{CC} = 3.0V		0.15	0.45	V
V _{OL1}	Output Low Voltage (Ports 1,2,3,4, WR, RD)	I _{OL} = 1.6mA			0.45	V
		I _{OL} = 100μA			0.3	V
V _{OL2}	Output Low Voltage (Port 0, ALE, PSEN)	I _{OL} = 3.2mA			0.45	V
		I _{OL} = 200μA			0.3	V
V _{OH}	Output High Voltage (Ports A,B,C,D)	I _{OH} = -20μA V _{CC} = 3.0V	2.9	2.99		V
		I _{OH} = -1mA V _{CC} = 3.0V	2.4	2.6		V
V _{OH1}	Output High Voltage (Ports 1,2,3,4, WR, RD)	I _{OH} = -20μA	2.0			V
		I _{OH} = -10μA	2.7			V
V _{OH2}	Output High Voltage (Port 0 in ext. Bus Mode, ALE, PSEN)) ⁴	I _{OH} = -800μA	2.0			V
		I _{OH} = -80μA	2.7			V
V _{OH3}	Output High Voltage V _{STBYON}	I _{OH} = -1μA	V _{STBY} - 0.8			V
V _{LVR}	Low Voltage Reset	0.1V hysteresis	2.3	2.5	2.7	V
V _{OP}	XTAL Open Bias Voltage (XTAL1, XTAL2)	I _{OL} = 3.2mA	1.0		2.0	V
V _{LKO}	V _{CC} (min) for Flash Erase and Program		1.5		2.2	V
V _{STBY}	SRAM (PSD) Stand-by Voltage		2.0		V _{CC} -0.2	V
V _{DF}	SRAM (PSD) Data Retention Voltage	Only on V _{STBY}	2			V
I _{IL}	Logic '0' Input Current (Ports 1,2,3,4)	V _{IN} = 0.45V (0V for Port 4[pin 2])	-1		-50	μA

Symbol	Parameter		Test Condition (in addition to those in Table 110, page 146)	Min.	Typ.	Max.	Unit
I _{TL}	Logic 1-to-0 Transition Current (Ports 1,2,3,4)		V _{IN} = 3.5V (2.5V for Port 4[pin 2])	-25		-250	μA
I _{STBY}	SRAM (PSD) Stand-by Current (V _{STBY} input)		V _{CC} = 0V		0.5	1	μA
I _{IDLE}	SRAM (PSD) Idle Current (V _{STBY} input)		V _{CC} > V _{STBY}	-0.1		0.1	μA
I _{RST}	Reset Pin Pull-up Current (RESET)		V _{IN} = V _{SS}	-10		-55	μA
I _{FR}	XTAL Feedback Resistor Current (XTAL1)		XTAL1 = V _{CC} XTAL2 = V _{SS}	-20		-50	μA
I _{LI}	Input Leakage Current		V _{SS} < V _{IN} < V _{CC}	-1		1	μA
I _{LO}	Output Leakage Current		0.45 < V _{OUT} < V _{CC}	-10		10	μA
I _{PD} ¹	Power-down Mode		V _{CC} = 3.6V LVD logic disabled			110	μA
			LVD logic enabled			180	μA
I _{CC_CPU} ^{2,3,6}	Active (12MHz)		V _{CC} = 3.6V		8	10	mA
	Idle (12MHz)				4	5	mA
	Active (24MHz)		V _{CC} = 3.6V		15	20	mA
	Idle (24MHz)				8	10	mA
I _{CC_PSD} (DC) ⁶	Operating Supply Current	PLD Only	PLD_TURBO = Off, f = 0MHz ⁷		0		μA/ PT ⁵
			PLD_TURBO = On, f = 0MHz		200	400	μA/ PT
		Flash memory	During Flash memory WRITE/Erase Only		10	25	mA
			Read-only, f = 0MHz		0	0	mA
		SRAM	f = 0MHz		0	0	mA
I _{CC_PSD} (AC) ⁶	PLD AC Base			note ⁵			
	Flash memory AC Adder				1.5	2.0	mA/ MHz
	SRAM AC Adder				0.8	1.5	mA/ MHz

- Note: 1. I_{PD} (Power-down Mode) is measured with:
XTAL1=V_{SS}; XTAL2=not connected; RESET=V_{CC}; Port 0 =V_{CC}; all other pins are disconnected. PLD not in Turbo mode.
2. I_{CC_CPU} (active mode) is measured with:
XTAL1 driven with t_{CLCH}, t_{CHCL} = 5ns, V_{IL} = V_{SS}+0.5V, V_{IH} = V_{CC} - 0.5V, XTAL2 = not connected; RESET=V_{SS}; Port 0=V_{CC}; all other pins are disconnected. I_{CC} would be slightly higher if a crystal oscillator is used (approximately 1mA).
3. I_{CC_CPU} (Idle Mode) is measured with:
XTAL1 driven with t_{CLCH}, t_{CHCL} = 5ns, V_{IL} = V_{SS}+0.5V, V_{IH} = V_{CC}- 0.5V, XTAL2 = not connected; Port 0 = V_{CC};
RESET=V_{CC}; all other pins are disconnected.
4. PLD is in non-Turbo Mode and none of the inputs are switching.
5. See Figure 72 for the PLD current calculation.
6. I/O current = 0 mA, all I/O pins are disconnected.

Figure 75. External Program Memory READ Cycle

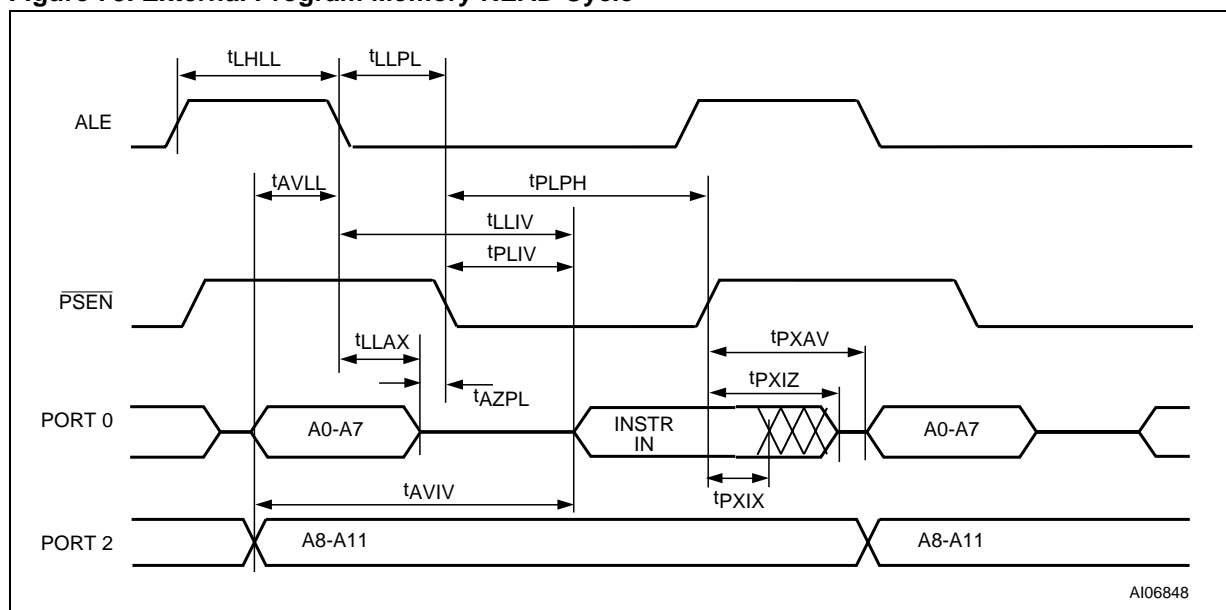

Table 114. External Program Memory AC Characteristics (with the 5V MCU Module)

Symbol	Parameter ¹	40MHz Oscillator		Variable Oscillator 1/t _{CLCL} = 24 to 40MHz		Unit
		Min	Max	Min	Max	
t _{LHLL}	ALE pulse width	35		2t _{CLCL} - 15		ns
t _{AVLL}	Address set-up to ALE	10		t _{CLCL} - 15		ns
t _{LLAX}	Address hold after ALE	10		t _{CLCL} - 15		ns
t _{LLIV}	ALE Low to valid instruction in		55		4t _{CLCL} - 45	ns
t _{LLPL}	ALE to PSEN	10		t _{CLCL} - 15		ns
t _{PLPH}	PSEN pulse width	60		3t _{CLCL} - 15		ns
t _{PLIV}	PSEN to valid instruction in		30		3t _{CLCL} - 45	ns
t _{PXIX}	Input instruction hold after PSEN	0		0		ns
t _{PXIZ} ²	Input instruction float after PSEN		15		t _{CLCL} - 10	ns
t _{PXAV} ²	Address valid after PSEN	20		t _{CLCL} - 5		ns
t _{AVIV}	Address to valid instruction in		70		5t _{CLCL} - 55	ns
t _{AZPL}	Address float to PSEN	-5		-5		ns

Note: 1. Conditions (in addition to those in Table 109, V_{CC} = 4.5 to 5.5V): V_{SS} = 0V; C_L for Port 0, ALE and PSEN output is 100pF; C_L for other outputs is 80pF
 2. Interfacing the μPSD325X devices to devices with float times up to 20ns is permissible. This limited bus contention does not cause any damage to Port 0 drivers.

Table 115. External Program Memory AC Characteristics (with the 3V MCU Module)

Symbol	Parameter ¹	24MHz Oscillator		Variable Oscillator 1/t _{CLCL} = 8 to 24MHz		Unit
		Min	Max	Min	Max	
t _{LHLL}	ALE pulse width	43		2t _{CLCL} – 40		ns
t _{AVLL}	Address set-up to ALE	17		t _{CLCL} – 25		ns
t _{LLAX}	Address hold after ALE	17		t _{CLCL} – 25		ns
t _{LLIV}	ALE Low to valid instruction in		80		4t _{CLCL} – 87	ns
t _{LLPL}	ALE to $\overline{\text{PSEN}}$	22		t _{CLCL} – 20		ns
t _{PLPH}	$\overline{\text{PSEN}}$ pulse width	95		3t _{CLCL} – 30		ns
t _{PLIV}	$\overline{\text{PSEN}}$ to valid instruction in		60		3t _{CLCL} – 65	ns
t _{PXIX}	Input instruction hold after $\overline{\text{PSEN}}$	0		0		ns
t _{PXIZ} ²	Input instruction float after $\overline{\text{PSEN}}$		32		t _{CLCL} – 10	ns
t _{PXAV} ²	Address valid after $\overline{\text{PSEN}}$	37		t _{CLCL} – 5		ns
t _{AVIV}	Address to valid instruction in		148		5t _{CLCL} – 60	ns
t _{AZPL}	Address float to $\overline{\text{PSEN}}$	–10		–10		ns

Note: 1. Conditions (in addition to those in Table 110, V_{CC} = 3.0 to 3.6V): V_{SS} = 0V; C_L for Port 0, ALE and PSEN output is 100pF, for 5V devices, and 50pF for 3V devices; C_L for other outputs is 80pF, for 5V devices, and 50pF for 3V devices)
 2. Interfacing the μPSD325X devices to devices with float times up to 35ns is permissible. This limited bus contention does not cause any damage to Port 0 drivers.

Table 116. External Clock Drive (with the 5V MCU Module)

Symbol	Parameter ¹	40MHz Oscillator		Variable Oscillator 1/t _{CLCL} = 24 to 40MHz		Unit
		Min	Max	Min	Max	
t _{RLRH}	Oscillator period			25	41.7	ns
t _{WLWH}	High time			10	t _{CLCL} – t _{CLCX}	ns
t _{LLAX2}	Low time			10	t _{CLCL} – t _{CLCX}	ns
t _{RHDX}	Rise time				10	ns
t _{RHDX}	Fall time				10	ns

Note: 1. Conditions (in addition to those in Table 109, V_{CC} = 4.5 to 5.5V): V_{SS} = 0V; C_L for Port 0, ALE and PSEN output is 100pF; C_L for other outputs is 80pF

Table 117. External Clock Drive (with the 3V MCU Module)

Symbol	Parameter ¹	24MHz Oscillator		Variable Oscillator 1/t _{CLCL} = 8 to 24MHz		Unit
		Min	Max	Min	Max	
t _{RLRH}	Oscillator period			41.7	125	ns
t _{WLWH}	High time			12	t _{CLCL} – t _{CLCX}	ns
t _{LLAX2}	Low time			12	t _{CLCL} – t _{CLCX}	ns
t _{RHDX}	Rise time				12	ns
t _{RHDX}	Fall time				12	ns

Note: 1. Conditions (in addition to those in Table 110, V_{CC} = 3.0 to 3.6V): V_{SS} = 0V; C_L for Port 0, ALE and PSEN output is 100pF, for 5V devices, and 50pF for 3V devices; C_L for other outputs is 80pF, for 5V devices, and 50pF for 3V devices)

Figure 76. External Data Memory READ Cycle

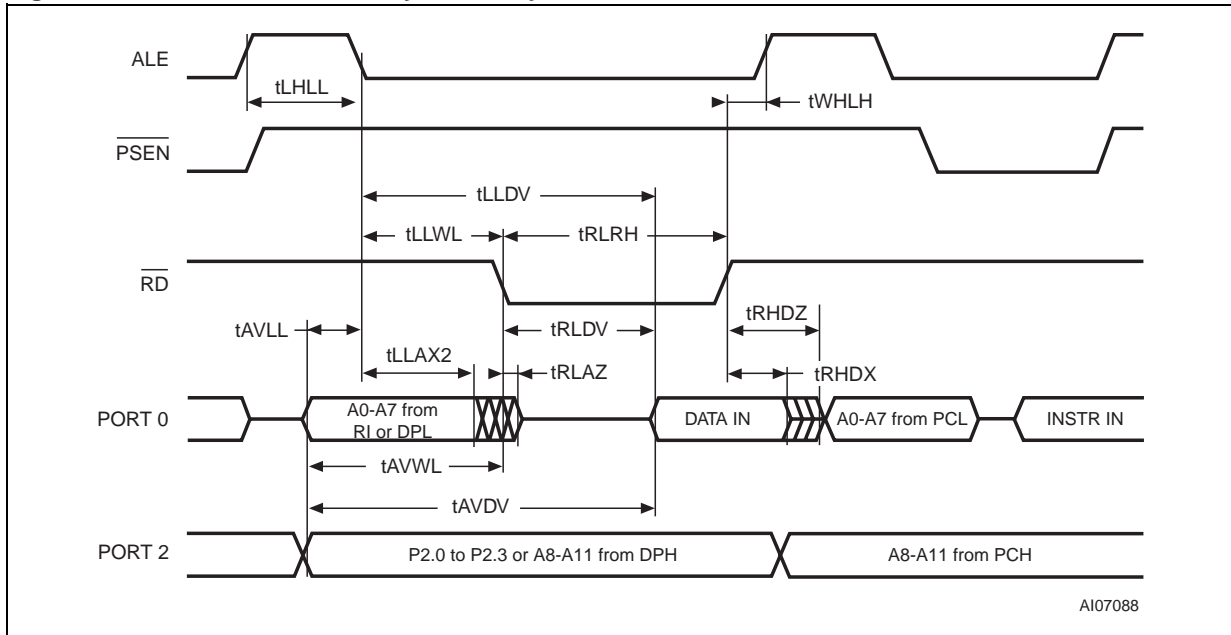

Figure 77. External Data Memory WRITE Cycle

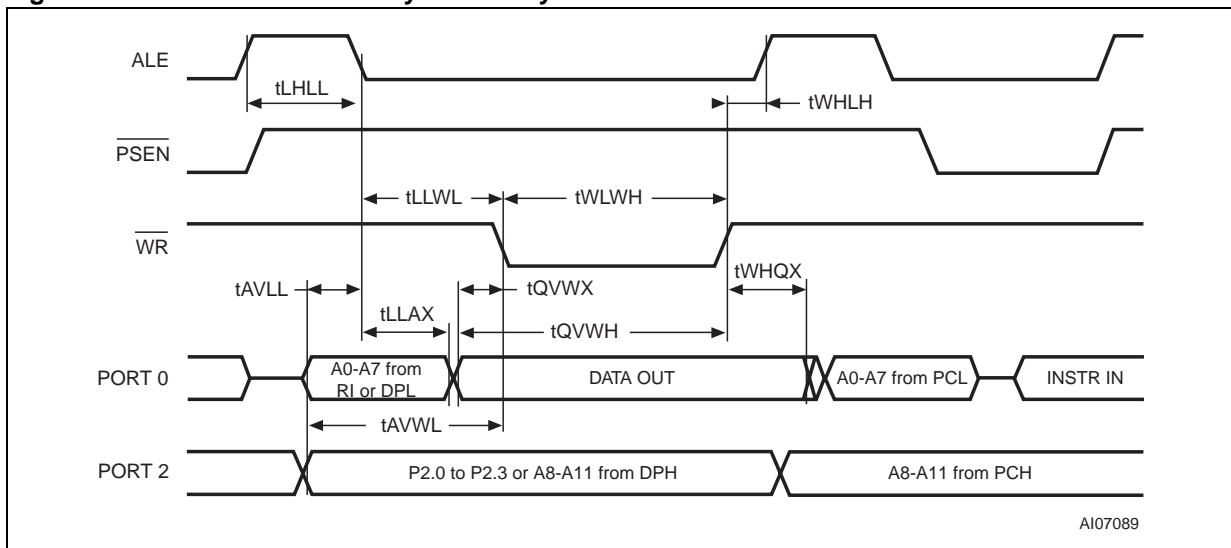

Table 118. External Data Memory AC Characteristics (with the 5V MCU Module)

Symbol	Parameter ¹	40MHz Oscillator		Variable Oscillator 1/t _{CLCL} = 24 to 40MHz		Unit
		Min	Max	Min	Max	
t _{RLRH}	\overline{RD} pulse width	120		6t _{CLCL} - 30		ns
t _{WLWH}	\overline{WR} pulse width	120		6t _{CLCL} - 30		ns
t _{LLAX2}	Address hold after ALE	10		t _{CLCL} - 15		ns
t _{RHDX}	\overline{RD} to valid data in		75		5t _{CLCL} - 50	ns
t _{RHDX}	Data hold after \overline{RD}	0		0		ns
t _{RHDZ}	Data float after \overline{RD}		38		2t _{CLCL} - 12	ns
t _{LLDV}	ALE to valid data in		150		8t _{CLCL} - 50	ns
t _{AVDV}	Address to valid data in		150		9t _{CLCL} - 75	ns
t _{LLWL}	ALE to \overline{WR} or \overline{RD}	60	90	3t _{CLCL} - 15	t _{CLCL} + 15	ns
t _{AVWL}	Address valid to \overline{WR} or \overline{RD}	70		4t _{CLCL} - 30		ns
t _{WHLH}	\overline{WR} or \overline{RD} High to ALE High	10	40	t _{CLCL} - 15	t _{CLCL} + 15	ns
t _{QVWX}	Data valid to \overline{WR} transition	5		t _{CLCL} - 20		ns
t _{QVWH}	Data set-up before \overline{WR}	125		7t _{CLCL} - 50		ns
t _{WHQX}	Data hold after \overline{WR}	5		t _{CLCL} - 20		ns
t _{RLAZ}	Address float after \overline{RD}		0		0	ns

Note: 1. Conditions (in addition to those in Table 109, V_{CC} = 4.5 to 5.5V): V_{SS} = 0V; C_L for Port 0, ALE and PSEN output is 100pF; C_L for other outputs is 80pF

μPSD325X DEVICES

Table 119. External Data Memory AC Characteristics (with the 3V MCU Module)

Symbol	Parameter ¹	24MHz Oscillator		Variable Oscillator 1/t _{CLCL} = 8 to 24MHz		Unit
		Min	Max	Min	Max	
t _{RLRH}	\overline{RD} pulse width	180		6t _{CLCL} - 70		ns
t _{WLWH}	\overline{WR} pulse width	180		6t _{CLCL} - 70		ns
t _{LLAX2}	Address hold after ALE	56		2t _{CLCL} - 27		ns
t _{RHDX}	\overline{RD} to valid data in		118		5t _{CLCL} - 90	ns
t _{RHDX}	Data hold after \overline{RD}	0		0		ns
t _{RHDZ}	Data float after \overline{RD}		63		2t _{CLCL} - 20	ns
t _{LLDV}	ALE to valid data in		200		8t _{CLCL} - 133	ns
t _{AVDV}	Address to valid data in		220		9t _{CLCL} - 155	ns
t _{LLWL}	ALE to \overline{WR} or \overline{RD}	75	175	3t _{CLCL} - 50	t _{CLCL} + 50	ns
t _{AVWL}	Address valid to \overline{WR} or \overline{RD}	67		4t _{CLCL} - 97		ns
t _{WHLH}	\overline{WR} or \overline{RD} High to ALE High	17	67	t _{CLCL} - 25	t _{CLCL} + 25	ns
t _{QVWX}	Data valid to \overline{WR} transition	5		t _{CLCL} - 37		ns
t _{QVWH}	Data set-up before \overline{WR}	170		7t _{CLCL} - 122		ns
t _{WHQX}	Data hold after \overline{WR}	15		t _{CLCL} - 27		ns
t _{RLAZ}	Address float after \overline{RD}		0		0	ns

Note: 1. Conditions (in addition to those in Table 110, V_{CC} = 3.0 to 3.6V): V_{SS} = 0V; C_L for Port 0, ALE and PSEN output is 100pF, for 5V devices, and 50pF for 3V devices; C_L for other outputs is 80pF, for 5V devices, and 50pF for 3V devices)

Table 120. A/D Analog Specification

Symbol	Parameter	Test Condition	Min.	Typ.	Max.	Unit
AV _{REF}	Analog Power Supply Input Voltage Range		V _{SS}		V _{CC}	V
V _{AN}	Analog Input Voltage Range		V _{SS} - 0.3		AV _{REF} + 0.3	V
I _{AVDD}	Current Following between V _{CC} and V _{SS}				200	μA
CA _{IN}	Overall Accuracy				±2	l.s.b.
N _{NLE}	Non-Linearity Error				±2	l.s.b.
N _{DNLE}	Differential Non-Linearity Error				±2	l.s.b.
N _{ZOE}	Zero-Offset Error				±2	l.s.b.
N _{FSE}	Full Scale Error				±2	l.s.b.
N _{GE}	Gain Error				±2	l.s.b.
T _{CONV}	Conversion Time	at 8MHz clock			20	μs

Figure 78. Input to Output Disable / Enable

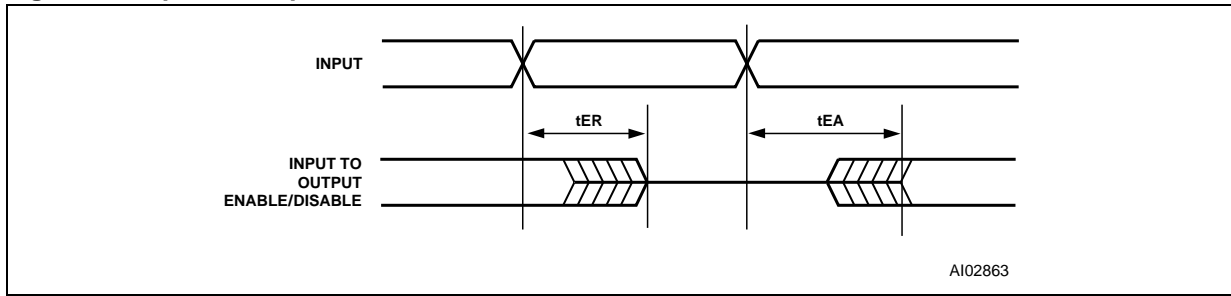

Table 121. CPLD Combinatorial Timing (5V Devices)

Symbol	Parameter	Conditions	Min	Max	PT Alloc	Turbo Off	Slew rate ¹	Unit
t _{PD} ²	CPLD Input Pin/Feedback to CPLD Combinatorial Output			20	+ 2	+ 10	- 2	ns
t _{EA}	CPLD Input to CPLD Output Enable			21		+ 10	- 2	ns
t _{ER}	CPLD Input to CPLD Output Disable			21		+ 10	- 2	ns
t _{ARP}	CPLD Register Clear or Preset Delay			21		+ 10	- 2	ns
t _{ARPW}	CPLD Register Clear or Preset Pulse Width		10			+ 10		ns
t _{ARD}	CPLD Array Delay	Any macrocell		11	+ 2			ns

Note: 1. Fast Slew Rate output available on PA3-PA0, PB3-PB0, and PD2-PD1. Decrement times by given amount
 2. t_{PD} for MCU address and control signals refers to delay from pins on Port 0, Port 2, RD WR, PSEN and ALE to CPLD combinatorial output (80-pin package only)

Table 122. CPLD Combinatorial Timing (3V Devices)

Symbol	Parameter	Conditions	Min	Max	PT Alloc	Turbo Off	Slew rate ¹	Unit
t _{PD} ²	CPLD Input Pin/Feedback to CPLD Combinatorial Output			40	+ 4	+ 20	- 6	ns
t _{EA}	CPLD Input to CPLD Output Enable			43		+ 20	- 6	ns
t _{ER}	CPLD Input to CPLD Output Disable			43		+ 20	- 6	ns
t _{ARP}	CPLD Register Clear or Preset Delay			40		+ 20	- 6	ns
t _{ARPW}	CPLD Register Clear or Preset Pulse Width		25			+ 20		ns
t _{ARD}	CPLD Array Delay	Any macrocell		25	+ 4			ns

Note: 1. Fast Slew Rate output available on PA3-PA0, PB3-PB0, and PD2-PD1. Decrement times by given amount
 2. t_{PD} for MCU address and control signals refers to delay from pins on Port 0, Port 2, RD WR, PSEN and ALE to CPLD combinatorial output (80-pin package only)

Figure 79. Synchronous Clock Mode Timing – PLD

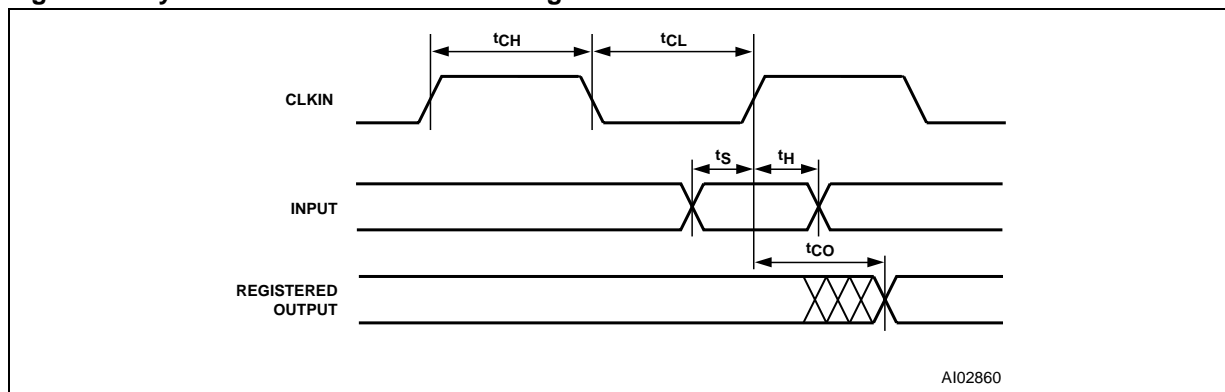

A102860

Table 123. CPLD Macrocell Synchronous Clock Mode Timing (5V Devices)

Symbol	Parameter	Conditions	Min	Max	PT Alloc	Turbo Off	Slew rate ¹	Unit
f _{MAX}	Maximum Frequency External Feedback	1/(t _s +t _{CO})		40.0				MHz
	Maximum Frequency Internal Feedback (f _{CNT})	1/(t _s +t _{CO} -10)		66.6				MHz
	Maximum Frequency Pipelined Data	1/(t _{CH} +t _{CL})		83.3				MHz
t _s	Input Setup Time		12		+ 2	+ 10		ns
t _H	Input Hold Time		0					ns
t _{CH}	Clock High Time	Clock Input	6					ns
t _{CL}	Clock Low Time	Clock Input	6					ns
t _{CO}	Clock to Output Delay	Clock Input		13			- 2	ns
t _{ARD}	CPLD Array Delay	Any macrocell		11	+ 2			ns
t _{MIN}	Minimum Clock Period ²	t _{CH} +t _{CL}	12					ns

Note: 1. Fast Slew Rate output available on PA3-PA0, PB3-PB0, and PD2-PD1. Decrement times by given amount.
 2. CLKIN (PD1) t_{CLCL} = t_{CH} + t_{CL}.

Table 124. CPLD Macrocell Synchronous Clock Mode Timing (3V Devices)

Symbol	Parameter	Conditions	Min	Max	PT Alloc	Turbo Off	Slew rate ¹	Unit
f _{MAX}	Maximum Frequency External Feedback	1/(t _s +t _{CO})		22.2				MHz
	Maximum Frequency Internal Feedback (f _{CNT})	1/(t _s +t _{CO} -10)		28.5				MHz
	Maximum Frequency Pipelined Data	1/(t _{CH} +t _{CL})		40.0				MHz
t _s	Input Setup Time		20		+ 4	+ 20		ns
t _H	Input Hold Time		0					ns
t _{CH}	Clock High Time	Clock Input	15					ns
t _{CL}	Clock Low Time	Clock Input	10					ns
t _{CO}	Clock to Output Delay	Clock Input		25			- 6	ns
t _{ARD}	CPLD Array Delay	Any macrocell		25	+ 4			ns
t _{MIN}	Minimum Clock Period ²	t _{CH} +t _{CL}	25					ns

Note: 1. Fast Slew Rate output available on PA3-PA0, PB3-PB0, and PD2-PD1. Decrement times by given amount.

2. CLKIN (PD1) t_{CLCL} = t_{CH} + t_{CL}.

Figure 80. Asynchronous RESET / Preset

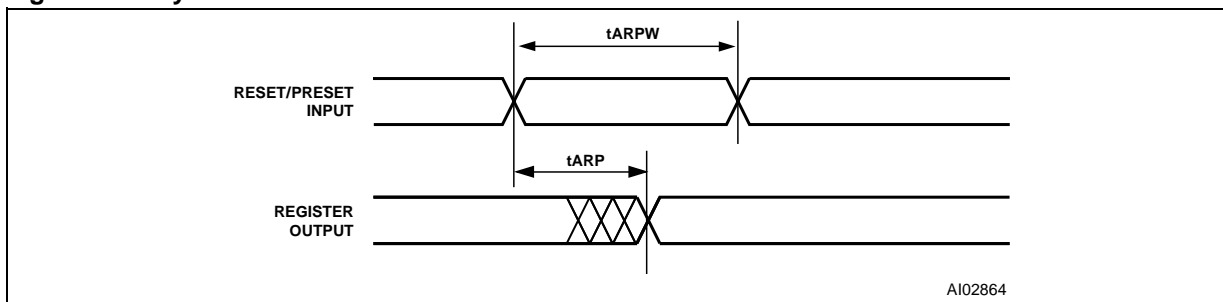

Figure 81. Asynchronous Clock Mode Timing (product term clock)

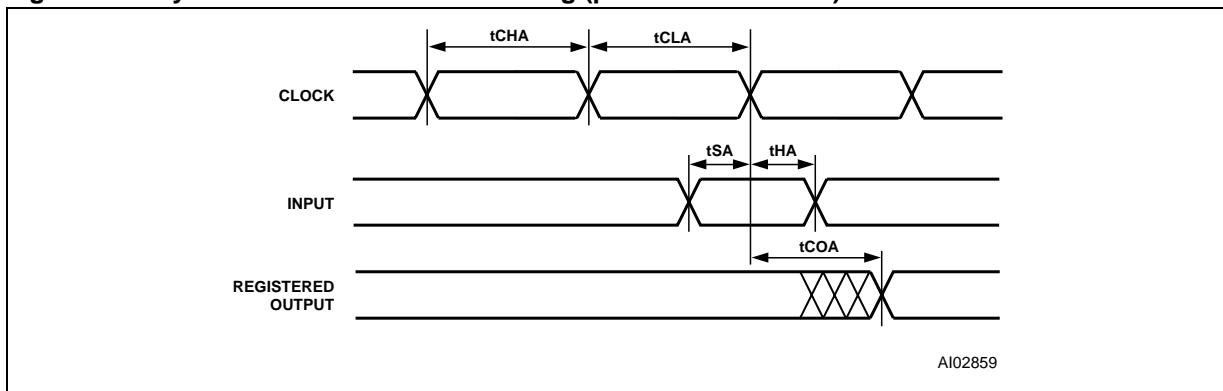

Table 125. CPLD Macrocell Asynchronous Clock Mode Timing (5V Devices)

Symbol	Parameter	Conditions	Min	Max	PT Alloc	Turbo Off	Slew Rate	Unit
f _{MAXA}	Maximum Frequency External Feedback	1/(t _{SA} +t _{COA})		38.4				MHz
	Maximum Frequency Internal Feedback (f _{CNTA})	1/(t _{SA} +t _{COA} -10)		62.5				MHz
	Maximum Frequency Pipelined Data	1/(t _{CHA} +t _{CLA})		71.4				MHz
t _{SA}	Input Setup Time		7		+ 2	+ 10		ns
t _{HA}	Input Hold Time		8					ns
t _{CHA}	Clock Input High Time		9			+ 10		ns
t _{CLA}	Clock Input Low Time		9			+ 10		ns
t _{COA}	Clock to Output Delay			21		+ 10	- 2	ns
t _{ARDA}	CPLD Array Delay	Any macrocell		11	+ 2			ns
t _{MINA}	Minimum Clock Period	1/f _{CNTA}	16					ns

Table 126. CPLD Macrocell Asynchronous Clock Mode Timing (3V Devices)

Symbol	Parameter	Conditions	Min	Max	PT Alloc	Turbo Off	Slew Rate	Unit
f _{MAXA}	Maximum Frequency External Feedback	1/(t _{SA} +t _{COA})		21.7				MHz
	Maximum Frequency Internal Feedback (f _{CNTA})	1/(t _{SA} +t _{COA} -10)		27.8				MHz
	Maximum Frequency Pipelined Data	1/(t _{CHA} +t _{CLA})		33.3				MHz
t _{SA}	Input Setup Time		10		+ 4	+ 20		ns
t _{HA}	Input Hold Time		12					ns
t _{CHA}	Clock High Time		17			+ 20		ns
t _{CLA}	Clock Low Time		13			+ 20		ns
t _{COA}	Clock to Output Delay			36		+ 20	- 6	ns
t _{ARD}	CPLD Array Delay	Any macrocell		25	+ 4			ns
t _{MINA}	Minimum Clock Period	1/f _{CNTA}	36					ns

Figure 82. Input Macrocell Timing (product term clock)

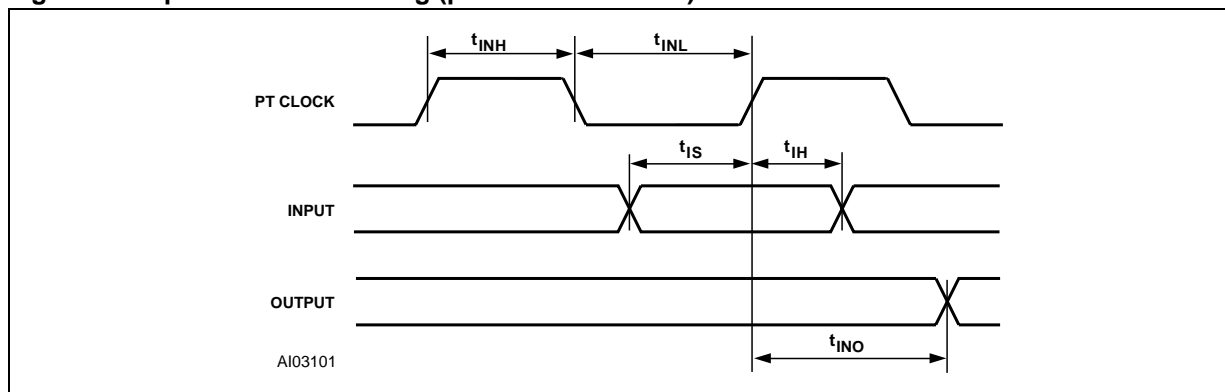

Table 127. Input Macrocell Timing (5V Devices)

Symbol	Parameter	Conditions	Min	Max	PT Alloc	Turbo Off	Unit
t_{IS}	Input Setup Time	(Note 1)	0				ns
t_{IH}	Input Hold Time	(Note 1)	15			+ 10	ns
t_{INH}	NIB Input High Time	(Note 1)	9				ns
t_{INL}	NIB Input Low Time	(Note 1)	9				ns
t_{INO}	NIB Input to Combinatorial Delay	(Note 1)		34	+ 2	+ 10	ns

Note: 1. Inputs from Port A, B, and C relative to register/ latch clock from the PLD. ALE/AS latch timings refer to t_{AVLX} and t_{LXAX} .

Table 128. Input Macrocell Timing (3V Devices)

Symbol	Parameter	Conditions	Min	Max	PT Alloc	Turbo Off	Unit
t_{IS}	Input Setup Time	(Note 1)	0				ns
t_{IH}	Input Hold Time	(Note 1)	25			+ 20	ns
t_{INH}	NIB Input High Time	(Note 1)	12				ns
t_{INL}	NIB Input Low Time	(Note 1)	12				ns
t_{INO}	NIB Input to Combinatorial Delay	(Note 1)		46	+ 4	+ 20	ns

Note: 1. Inputs from Port A, B, and C relative to register/latch clock from the PLD. ALE latch timings refer to t_{AVLX} and t_{LXAX} .

Table 129. Program, WRITE and Erase Times (5V Devices)

Symbol	Parameter	Min.	Typ.	Max.	Unit
	Flash Program		8.5		s
	Flash Bulk Erase ¹ (pre-programmed)		3	30	s
	Flash Bulk Erase (not pre-programmed)		5		s
t _{WHQV3}	Sector Erase (pre-programmed)		1	30	s
t _{WHQV2}	Sector Erase (not pre-programmed)		2.2		s
t _{WHQV1}	Byte Program		14	1200	μs
	Program / Erase Cycles (per Sector)	100,000			cycles
t _{WHWLO}	Sector Erase Time-Out		100		μs
t _{Q7VQV}	DQ7 Valid to Output (DQ7-DQ0) Valid (Data Polling) ²			30	ns

Note: 1. Programmed to all zero before erase.
 2. The polling status, DQ7, is valid t_{Q7VQV} time units before the data byte, DQ0-DQ7, is valid for reading.

Table 130. Program, WRITE and Erase Times (3V Devices)

Symbol	Parameter	Min.	Typ.	Max.	Unit
	Flash Program		8.5		s
	Flash Bulk Erase ¹ (pre-programmed)		3	30	s
	Flash Bulk Erase (not pre-programmed)		5		s
t _{WHQV3}	Sector Erase (pre-programmed)		1	30	s
t _{WHQV2}	Sector Erase (not pre-programmed)		2.2		s
t _{WHQV1}	Byte Program		14	1200	μs
	Program / Erase Cycles (per Sector)	100,000			cycles
t _{WHWLO}	Sector Erase Time-Out		100		μs
t _{Q7VQV}	DQ7 Valid to Output (DQ7-DQ0) Valid (Data Polling) ²			30	ns

Note: 1. Programmed to all zero before erase.
 2. The polling status, DQ7, is valid t_{Q7VQV} time units before the data byte, DQ0-DQ7, is valid for reading.

Figure 83. Peripheral I/O READ Timing

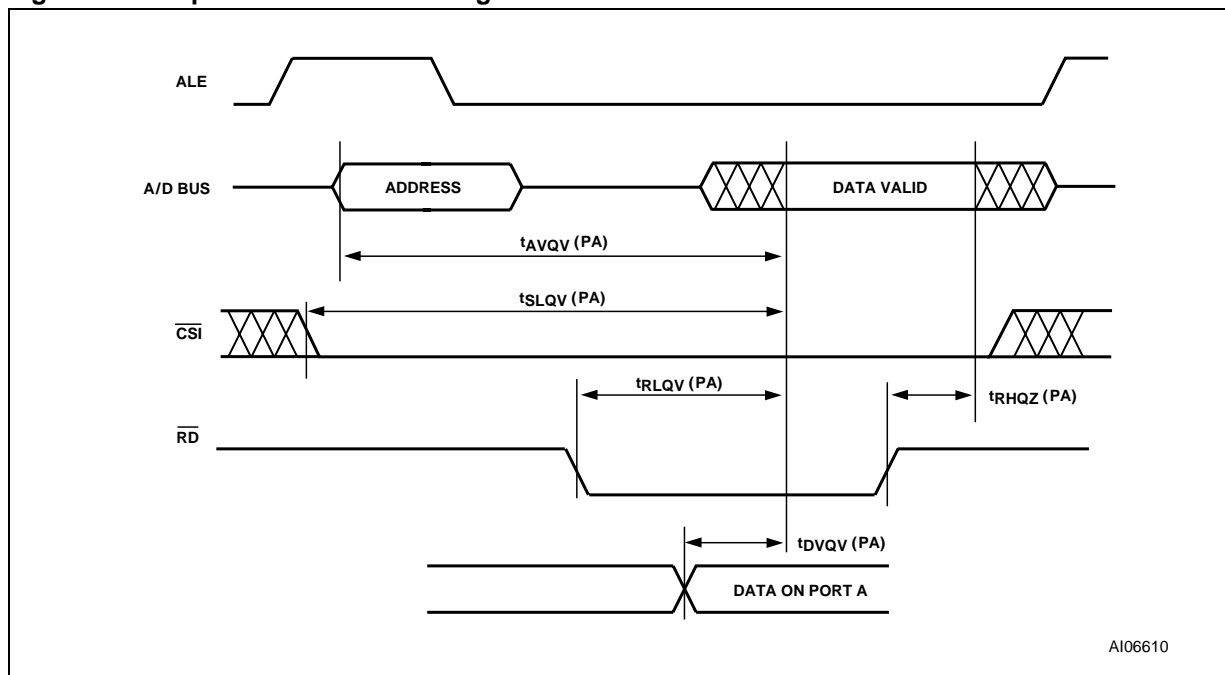

AI06610

Table 131. Port A Peripheral Data Mode READ Timing (5V Devices)

Symbol	Parameter	Conditions	Min	Max	Turbo Off	Unit
t _{AVQV-PA}	Address Valid to Data Valid	(Note ¹)		37	+ 10	ns
t _{SLQV-PA}	\overline{CS} Valid to Data Valid			27	+ 10	ns
t _{RLQV-PA}	\overline{RD} to Data Valid	(Note ²)		32		ns
t _{DVQV-PA}	Data In to Data Out Valid			22		ns
t _{RHQZ-PA}	\overline{RD} to Data High-Z			23		ns

Note: 1. Any input used to select Port A Data Peripheral Mode.
 2. Data is already stable on Port A.

Table 132. Port A Peripheral Data Mode READ Timing (3V Devices)

Symbol	Parameter	Conditions	Min	Max	Turbo Off	Unit
t _{AVQV-PA}	Address Valid to Data Valid	(Note ¹)		50	+ 20	ns
t _{SLQV-PA}	\overline{CS} Valid to Data Valid			37	+ 20	ns
t _{RLQV-PA}	\overline{RD} to Data Valid	(Note ²)		45		ns
t _{DVQV-PA}	Data In to Data Out Valid			38		ns
t _{RHQZ-PA}	\overline{RD} to Data High-Z			36		ns

Note: 1. Any input used to select Port A Data Peripheral Mode.
 2. Data is already stable on Port A.

Figure 84. Peripheral I/O WRITE Timing

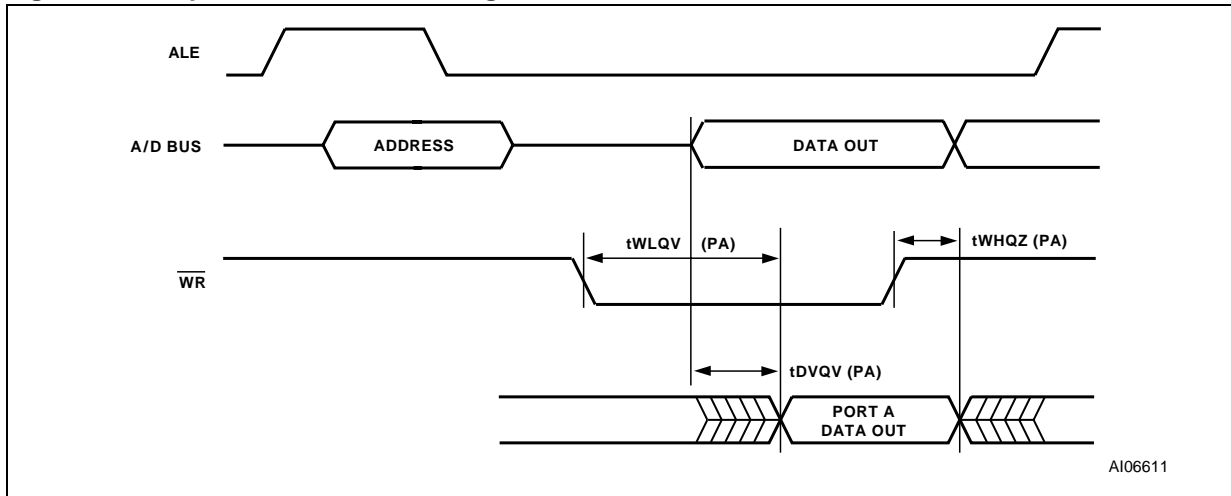

Table 133. Port A Peripheral Data Mode WRITE Timing (5V Devices)

Symbol	Parameter	Conditions	Min	Max	Unit
$t_{WLQV-PA}$	\overline{WR} to Data Propagation Delay			25	ns
$t_{DVQV-PA}$	Data to Port A Data Propagation Delay	(Note 1)		22	ns
$t_{WHQZ-PA}$	\overline{WR} Invalid to Port A Tri-state			20	ns

Note: 1. Data stable on Port 0 pins to data on Port A.

Table 134. Port A Peripheral Data Mode WRITE Timing (3V Devices)

Symbol	Parameter	Conditions	Min	Max	Unit
$t_{WLQV-PA}$	\overline{WR} to Data Propagation Delay			42	ns
$t_{DVQV-PA}$	Data to Port A Data Propagation Delay	(Note 1)		38	ns
$t_{WHQZ-PA}$	\overline{WR} Invalid to Port A Tri-state			33	ns

Note: 1. Data stable on Port 0 pins to data on Port A.

Figure 85. Reset ($\overline{\text{RESET}}$) Timing

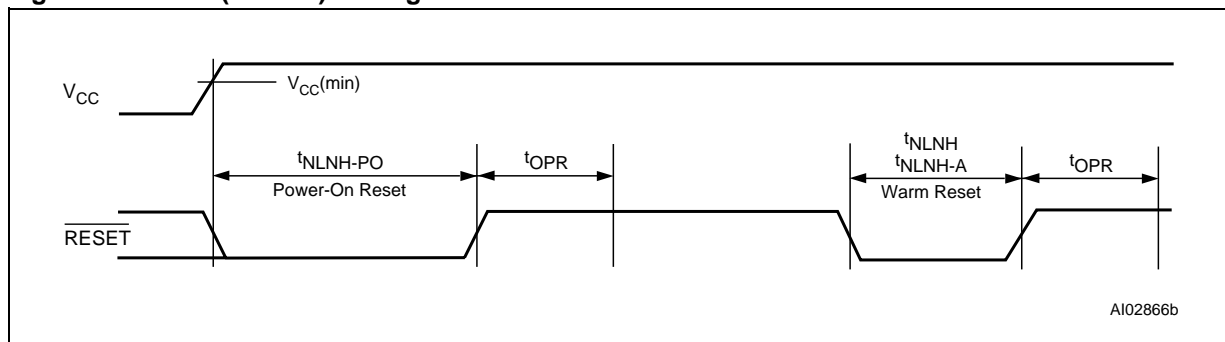

Table 135. Reset ($\overline{\text{RESET}}$) Timing (5V Devices)

Symbol	Parameter	Conditions	Min	Max	Unit
t_{NINH}	$\overline{\text{RESET}}$ Active Low Time ¹		150		ns
$t_{\text{NINH-PO}}$	Power-on Reset Active Low Time		1		ms
$t_{\text{NINH-A}}$	Warm $\overline{\text{RESET}}$ ²		25		μs
t_{OPR}	$\overline{\text{RESET}}$ High to Operational Device			120	ns

Note: 1. Reset ($\overline{\text{RESET}}$) does not reset Flash memory Program or Erase cycles.
 2. Warm $\overline{\text{RESET}}$ aborts Flash memory Program or Erase cycles, and puts the device in READ Mode.

Table 136. Reset ($\overline{\text{RESET}}$) Timing (3V Devices)

Symbol	Parameter	Conditions	Min	Max	Unit
t_{NINH}	$\overline{\text{RESET}}$ Active Low Time ¹		300		ns
$t_{\text{NINH-PO}}$	Power-on Reset Active Low Time		1		ms
$t_{\text{NINH-A}}$	Warm $\overline{\text{RESET}}$ ²		25		μs
t_{OPR}	$\overline{\text{RESET}}$ High to Operational Device			300	ns

Note: 1. Reset ($\overline{\text{RESET}}$) does not reset Flash memory Program or Erase cycles.
 2. Warm $\overline{\text{RESET}}$ aborts Flash memory Program or Erase cycles, and puts the device in READ Mode.

Table 137. V_{STBYON} Definitions Timing (5V Devices)

Symbol	Parameter	Conditions	Min	Typ	Max	Unit
t_{BVBH}	V_{STBY} Detection to V_{STBYON} Output High	(Note ¹)		20		μs
t_{BXBL}	V_{STBY} Off Detection to V_{STBYON} Output Low	(Note ¹)		20		μs

Note: 1. V_{STBYON} timing is measured at V_{CC} ramp rate of 2ms.

Table 138. V_{STBYON} Timing (3V Devices)

Symbol	Parameter	Conditions	Min	Typ	Max	Unit
t_{BVBH}	V_{STBY} Detection to V_{STBYON} Output High	(Note ¹)		20		μs
t_{BXBL}	V_{STBY} Off Detection to V_{STBYON} Output Low	(Note ¹)		20		μs

Note: 1. V_{STBYON} timing is measured at V_{CC} ramp rate of 2ms.

Figure 86. ISC Timing

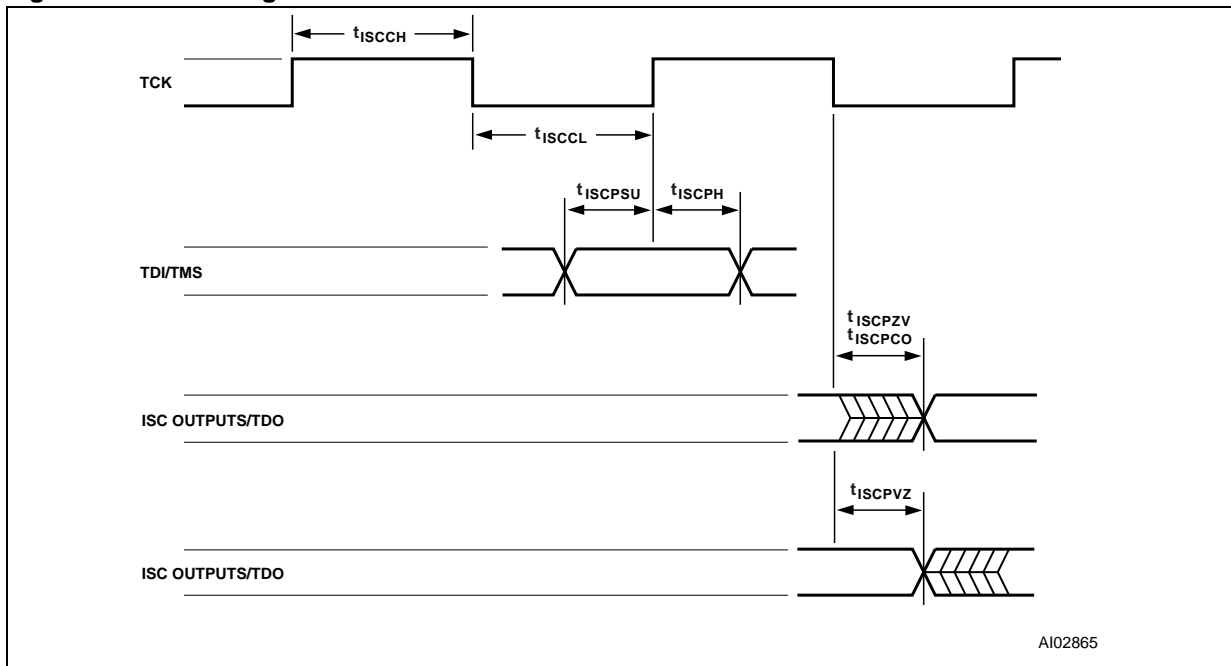

Table 139. ISC Timing (5V Devices)

Symbol	Parameter	Conditions	Min	Max	Unit
t_{ISCCF}	Clock (TCK, PC1) Frequency (except for PLD)	(Note ¹)		20	MHz
t_{ISCCH}	Clock (TCK, PC1) High Time (except for PLD)	(Note ¹)	23		ns
t_{ISCCL}	Clock (TCK, PC1) Low Time (except for PLD)	(Note ¹)	23		ns
t_{ISCCFP}	Clock (TCK, PC1) Frequency (PLD only)	(Note ²)		2	MHz
t_{ISCCHP}	Clock (TCK, PC1) High Time (PLD only)	(Note ²)	240		ns
t_{ISCCLP}	Clock (TCK, PC1) Low Time (PLD only)	(Note ²)	240		ns
t_{ISCPSU}	ISC Port Set Up Time		7		ns
t_{ISCPH}	ISC Port Hold Up Time		5		ns
t_{ISPCO}	ISC Port Clock to Output			21	ns
t_{ISCPZV}	ISC Port High-Impedance to Valid Output			21	ns
t_{ISCPVZ}	ISC Port Valid Output to High-Impedance			21	ns

Note: 1. For non-PLD Programming, Erase or in ISC By-pass Mode.
 2. For Program or Erase PLD only.

μPSD325X DEVICES

Table 140. ISC Timing (3V Devices)

Symbol	Parameter	Conditions	Min	Max	Unit
t _{ISCCF}	Clock (TCK, PC1) Frequency (except for PLD)	(Note ¹)		12	MHz
t _{ISCCH}	Clock (TCK, PC1) High Time (except for PLD)	(Note ¹)	40		ns
t _{ISCCL}	Clock (TCK, PC1) Low Time (except for PLD)	(Note ¹)	40		ns
t _{ISCCFP}	Clock (TCK, PC1) Frequency (PLD only)	(Note ²)		2	MHz
t _{ISCCHP}	Clock (TCK, PC1) High Time (PLD only)	(Note ²)	240		ns
t _{ISCCLP}	Clock (TCK, PC1) Low Time (PLD only)	(Note ²)	240		ns
t _{ISCP_{SU}}	ISC Port Set Up Time		12		ns
t _{ISCP_H}	ISC Port Hold Up Time		5		ns
t _{ISCP_{CO}}	ISC Port Clock to Output			30	ns
t _{ISCP_{ZV}}	ISC Port High-Impedance to Valid Output			30	ns
t _{ISCP_{VZ}}	ISC Port Valid Output to High-Impedance			30	ns

Note: 1. For non-PLD Programming, Erase or in ISC By-pass Mode.
 2. For Program or Erase PLD only.

Figure 87. MCU Module AC Measurement I/O Waveform

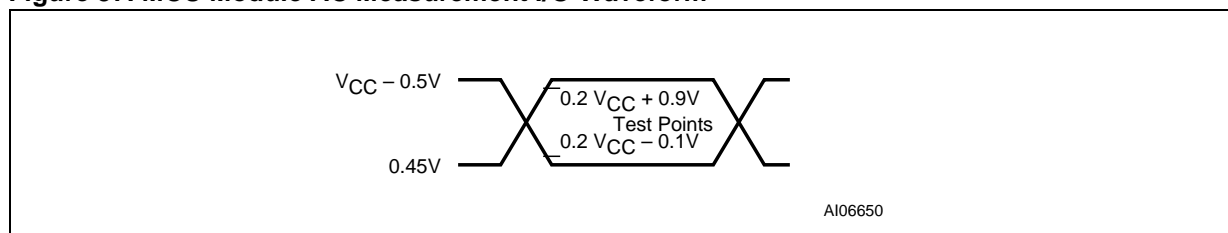

Note: AC inputs during testing are driven at $V_{CC}-0.5V$ for a logic '1,' and $0.45V$ for a logic '0.'
 Timing measurements are made at $V_{IH}(\min)$ for a logic '1,' and $V_{IL}(\max)$ for a logic '0'

Figure 88. PSD MODULE AC Float I/O Waveform

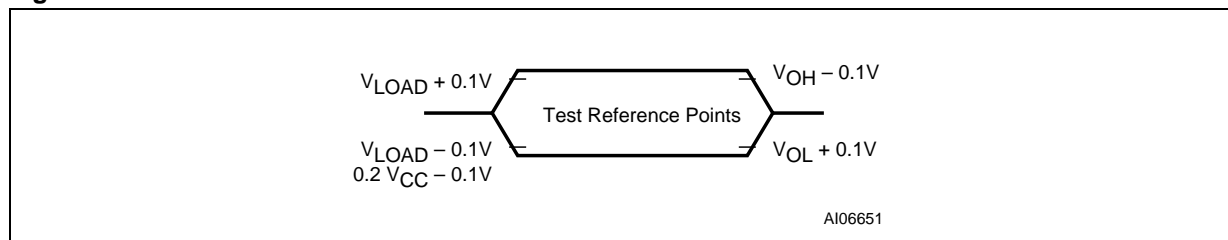

Note: For timing purposes, a Port pin is considered to be no longer floating when a 100mV change from load voltage occurs, and begins to float when a 100mV change from the loaded V_{OH} or V_{OL} level occurs
 I_{OL} and $I_{OH} \geq 20mA$

Figure 89. External Clock Cycle

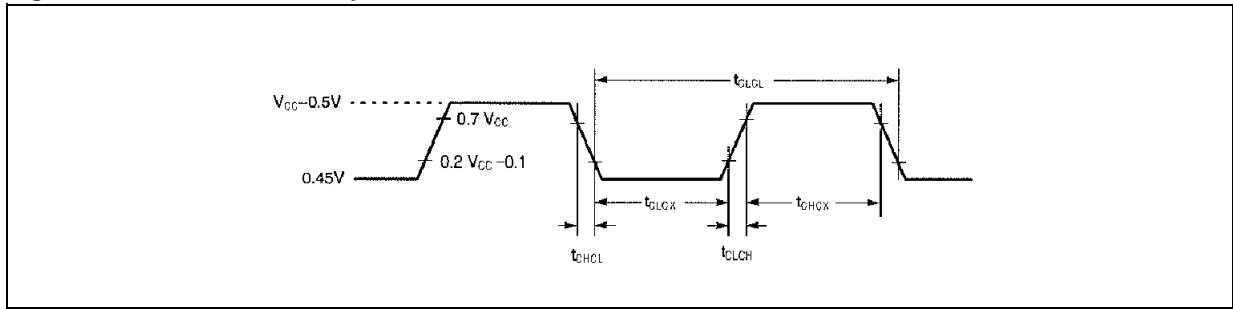
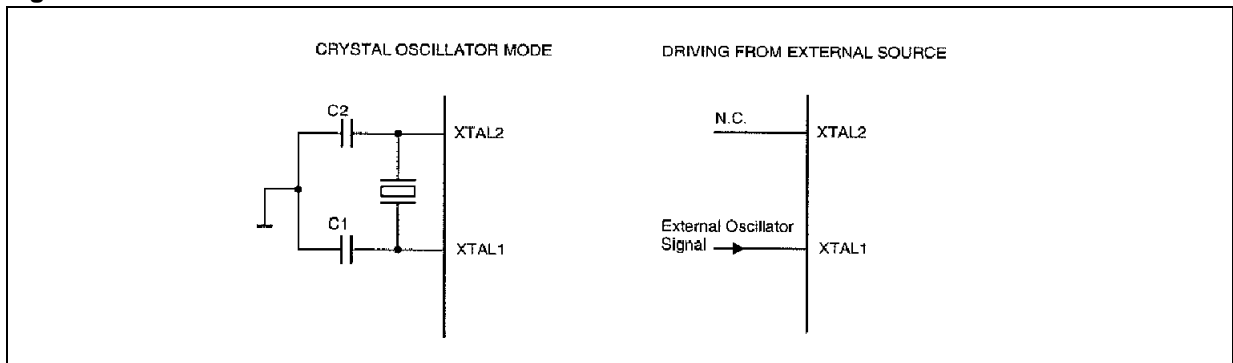

Figure 90. Recommended Oscillator Circuits



Note: C1, C2 = 30pF ± 10pF for crystals

For ceramic resonators, contact resonator manufacturer

Oscillation circuit is designed to be used either with a ceramic resonator or crystal oscillator. Since each crystal and ceramic resonator have their own characteristics, the user should consult the crystal manufacturer for appropriate values of external components.

Figure 91. PSD MODULE AC Measurement I/O Waveform

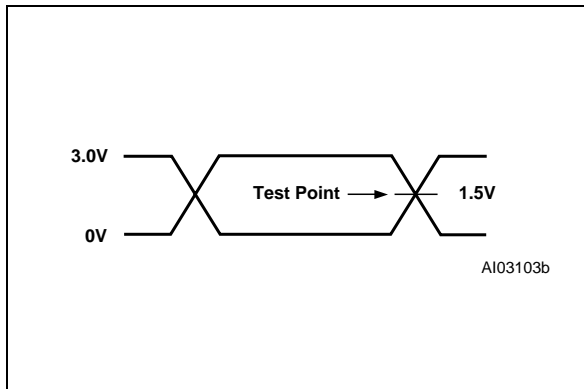

Figure 92. PSD MODULE AC Measurement Load Circuit

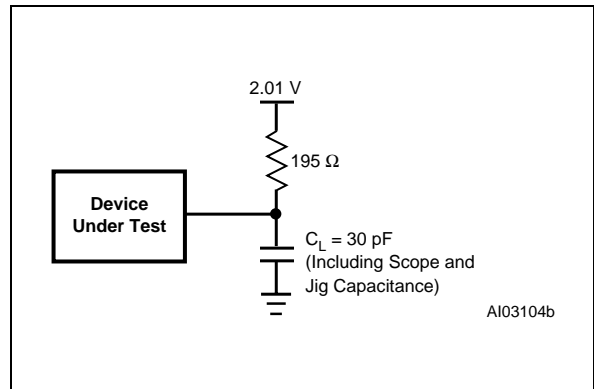

Table 141. Capacitance

Symbol	Parameter	Test Condition	Typ. ²	Max.	Unit
C _{IN}	Input Capacitance (for input pins)	V _{IN} = 0V	4	6	pF
C _{OUT}	Output Capacitance (for input/output pins)	V _{OUT} = 0V	8	12	pF

Note: 1. Sampled only, not 100% tested.

2. Typical values are for T_A = 25°C and nominal supply voltages.

PACKAGE MECHANICAL INFORMATION

Figure 93. TQFP52 – 52-lead Plastic Quad Flatpack Package Outline

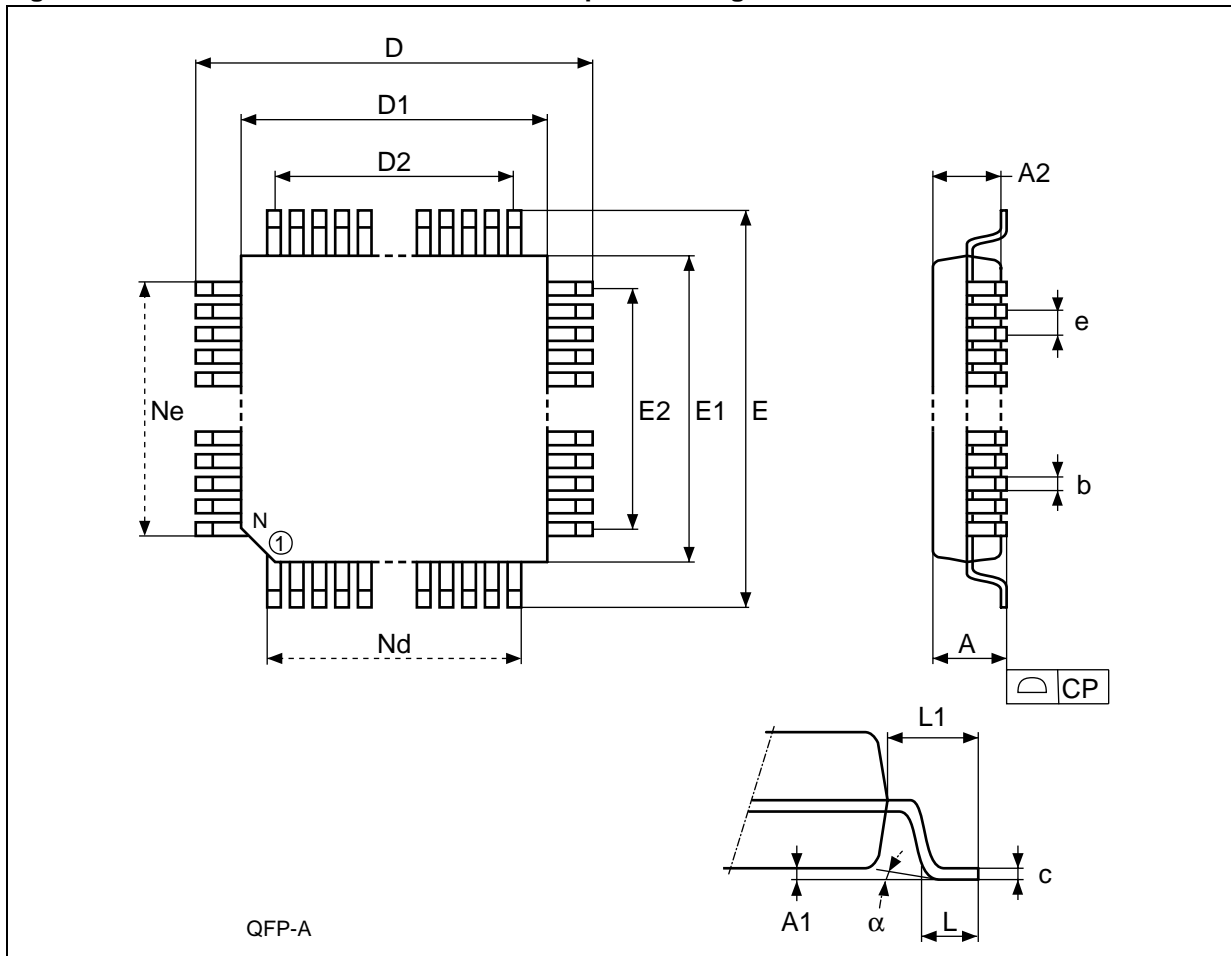

Note: Drawing is not to scale.

Table 142. TQFP52 – 52-lead Plastic Quad Flatpack Package Mechanical Data

Symb	mm			inches		
	Typ	Min	Max	Typ	Min	Max
A	–	–	1.75	–	–	0.069
A1	–	0.05	0.020	–	0.002	0.008
A2	–	1.25	1.55	–	0.049	0.061
b	–	0.02	0.04	–	0.007	0.016
c	–	0.07	0.23	–	0.002	0.009
D	12.00	–	–	0.473	–	–
D1	10.00	–	–	0.394	–	–
D2						
E	12.00	–	–	0.473	–	–
E1	10.00	–	–	0.394	–	–
E2						
e	0.65	–	–	0.026	–	–
L	–	0.45	0.75	–	0.018	0.030
L1	1.00	–	–	0.039	–	–
α	–	0°	7°	–	0°	7°
n	52			52		
Nd	13			13		
Ne	13			13		
CP	–	–	0.10	–	–	0.004

Figure 94. TQFP80 – 80-lead Plastic Quad Flatpack Package Outline

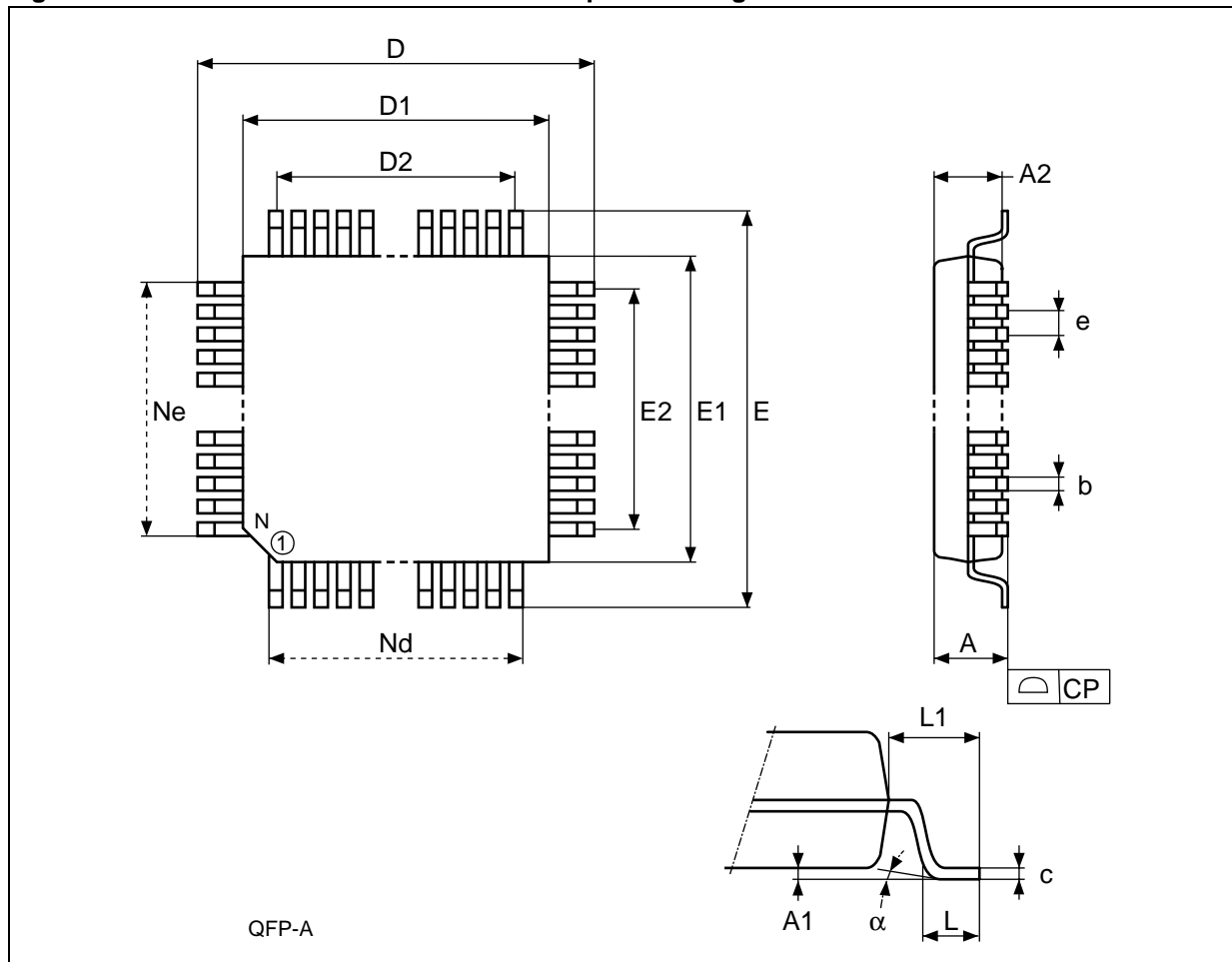

Note: Drawing is not to scale.

Table 143. TQFP80 – 80-lead Plastic Quad Flatpack Package Mechanical Data

Symb	mm			inches		
	Typ	Min	Max	Typ	Min	Max
A	–	–	1.60	–	–	0.063
A1	–	0.05	0.15	–	0.002	0.006
A2	1.40	1.35	1.45	0.055	0.053	0.057
b	0.22	0.17	0.27	0.009	0.007	0.011
c	–	0.09	0.20	–	0.004	0.008
D	14.00	–	–	0.551	–	–
D1	12.00	–	–	0.472	–	–
D2	9.50	–	–	0.374	–	–
E	14.00	–	–	0.473	–	–
E1	12.00	–	–	0.394	–	–
E2	9.50	–	–	0.374	–	–
e	0.50	–	–	0.020	–	–
L	0.60	0.45	0.75	0.024	0.018	0.030
L1	1.00	–	–	0.039	–	–
α	3.5	0°	7°	3.5	0°	7°
n	80			80		
Nd	20			20		
Ne	20			20		
CP	–	–	0.08	–	–	0.003

μPSD325X DEVICES

PART NUMBERING

Table 144. Ordering Information Scheme

Example:	μPSD	3	2	5	4	B	V	-	24	U	6	T
Device Type	μPSD = Microcontroller PSD											
Family	3 = 8032 core											
PLD Size	2 = 16 Macrocells											
SRAM Size	5 = 256Kbit											
Main Flash Memory Size	3 = 1Mbit 4 = 2Mbit											
IP Mix	A = USB, I ² C, PWM, DDC, ADC, (2) UARTs Supervisor (Reset Out, Reset In, LVD, WD) B = I ² C, PWM, DDC, ADC, (2) UARTs Supervisor (Reset Out, Reset In, LVD, WD)											
Operating Voltage	blank = V _{CC} = 4.5 to 5.5V V = V _{CC} = 3.0 to 3.6V											
Speed	-24 = 24MHz -40 = 40MHz											
Package	T = 52-pin TQFP U = 80-pin TQFP											
Temperature Range	1 = 0 to 70°C 6 = -40 to 85°C											
Shipping Option	T = Tape and Reel Packing											

For a list of available options (e.g., Speed, Package) or for further information on any aspect of this device, please contact your nearest ST Sales Office.

REVISION HISTORY

Table 145. Document Revision History

Date	Rev. #	Revision Details
26-Nov-2002	1.0	First Issue

Information furnished is believed to be accurate and reliable. However, STMicroelectronics assumes no responsibility for the consequences of use of such information nor for any infringement of patents or other rights of third parties which may result from its use. No license is granted by implication or otherwise under any patent or patent rights of STMicroelectronics. Specifications mentioned in this publication are subject to change without notice. This publication supersedes and replaces all information previously supplied. STMicroelectronics products are not authorized for use as critical components in life support devices or systems without express written approval of STMicroelectronics.

The ST logo is registered trademark of STMicroelectronics
All other names are the property of their respective owners

© 2002 STMicroelectronics - All Rights Reserved

STMicroelectronics group of companies
Australia - Brazil - Canada - China - Finland - France - Germany - Hong Kong -
India - Israel - Italy - Japan - Malaysia - Malta - Morocco - Singapore - Spain - Sweden - Switzerland - United Kingdom - United States.
www.st.com