

<b>HIGH PERFORMANCE</b>	<b>30</b>	<b>35</b>	<b>40</b>	<b>45</b>	<b>50</b>
Max. $\overline{\text{RAS}}$ Access Time, ( $t_{\text{RAC}}$ )	30 ns	35 ns	40 ns	45 ns	50 ns
Max. Column Address Access Time, ( $t_{\text{CAA}}$ )	16 ns	18 ns	20 ns	22 ns	24 ns
Min. Extended Data Out Page Mode Cycle Time, ( $t_{\text{PC}}$ )	12 ns	14 ns	15 ns	17 ns	19 ns
Min. Read/Write Cycle Time, ( $t_{\text{RC}}$ )	65 ns	70 ns	75 ns	80 ns	90 ns

**Features**

- 128K x 16-bit organization
- EDO Page Mode for a sustained data rate of 83 MHz
- $\overline{\text{RAS}}$  access time: 30, 35, 40, 45, 50 ns
- Dual  $\overline{\text{CAS}}$  Input
- Low power dissipation
- Read-Modify-Write,  $\overline{\text{RAS}}$ -Only Refresh,  $\overline{\text{CAS}}$ -Before- $\overline{\text{RAS}}$  Refresh
- Refresh Interval: 512 cycles/8 ms
- Available in 40-pin 400 mil SOJ and 40/44L-pin 400 mil TSOP-II packages
- Single +5V  $\pm$ 10% Power Supply
- TTL Interface

**Description**

The V53C16128H is a 131,072 x 16 bit high-performance CMOS dynamic random access memory. The V53C16128H offers Page mode with Extended Data Output. EDO Page Mode operation allows random access up to 256 x 16 bits, within a page, with cycle times as short as 12ns. An address,  $\overline{\text{CAS}}$  and  $\overline{\text{RAS}}$  input capacitances are reduced to minimize the loading. The V53C16128H has asymmetric address, 9-bit row and 8-bit column.

All inputs are TTL compatible. The V53C16128H is best suited for graphics, and DSP applications requiring high performance memories.

**Device Usage Chart**

Operating Temperature Range	Package Outline		Access Time (ns)					Power	Temperature Mark
	K	T	30	35	40	45	50	Std.	
0°C to 70 °C	•	•	•	•	•	•	•	•	Blank

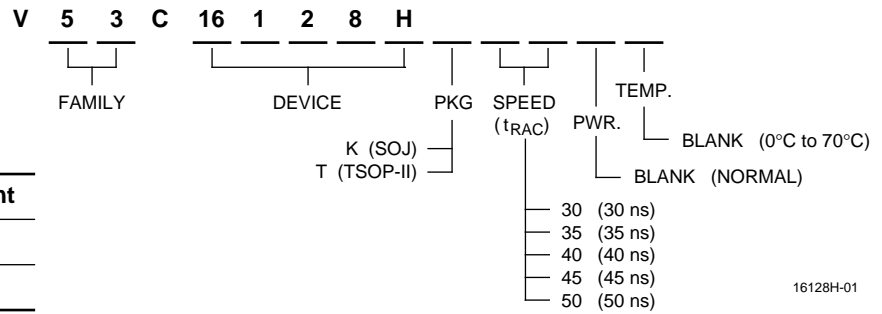

Description	Pkg.	Pin Count
SOJ	K	40
TSOP-II	T	40/44L

16128H-01

**40-Pin Plastic SOJ  
PIN CONFIGURATION  
Top View**

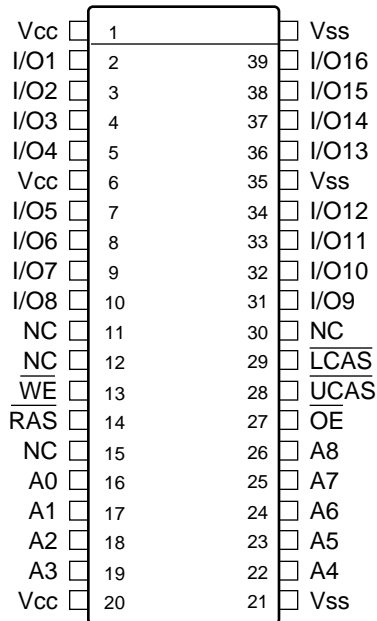

16128H-02

**40/44L-Pin Plastic TSOP-II  
PIN CONFIGURATION  
Top View**

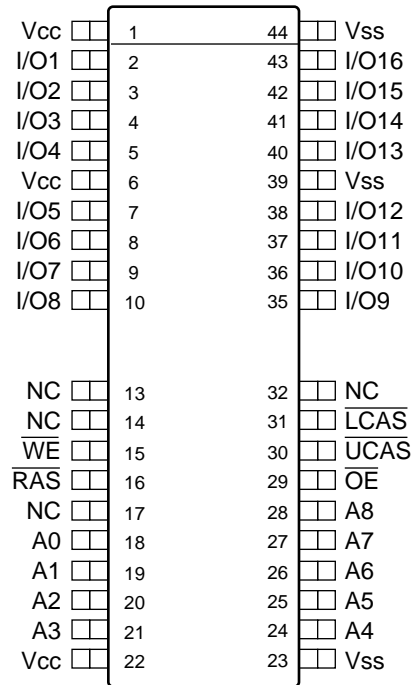

16128H-03

**Pin Names**

A <sub>0</sub> -A <sub>8</sub>	Address Inputs
$\overline{\text{RAS}}$	Row Address Strobe
$\overline{\text{UCAS}}$	Column Address Strobe/Upper Byte Control
$\overline{\text{LCAS}}$	Column Address Strobe/Lower Byte Control
$\overline{\text{WE}}$	Write Enable
$\overline{\text{OE}}$	Output Enable
I/O <sub>1</sub> -I/O <sub>16</sub>	Data Input, Output
V <sub>CC</sub>	+5V Supply
V <sub>SS</sub>	0V Supply
NC	No Connect

**Absolute Maximum Ratings\***

Ambient Temperature  
 Under Bias ..... -10°C to +80°C  
 Storage Temperature (plastic) ..... -55°C to +125°C  
 Voltage Relative to V<sub>SS</sub> ..... -1.0 V to +7.0 V  
 Data Output Current ..... 50 mA  
 Power Dissipation ..... 1.0 W

\*Note: Operation above Absolute Maximum Ratings can adversely affect device reliability.

**Capacitance\***

T<sub>A</sub> = 25°C, V<sub>CC</sub> = 5 V ± 10%, V<sub>SS</sub> = 0 V

Symbol	Parameter	Typ.	Max.	Unit
C <sub>IN1</sub>	Address Input	3	4	pF
C <sub>IN2</sub>	RAS, UCAS, LCAS, WE, OE	4	5	pF
C <sub>OUT</sub>	Data Input/Output	5	7	pF

\*Note: Capacitance is sampled and not 100% tested

**Block Diagram**

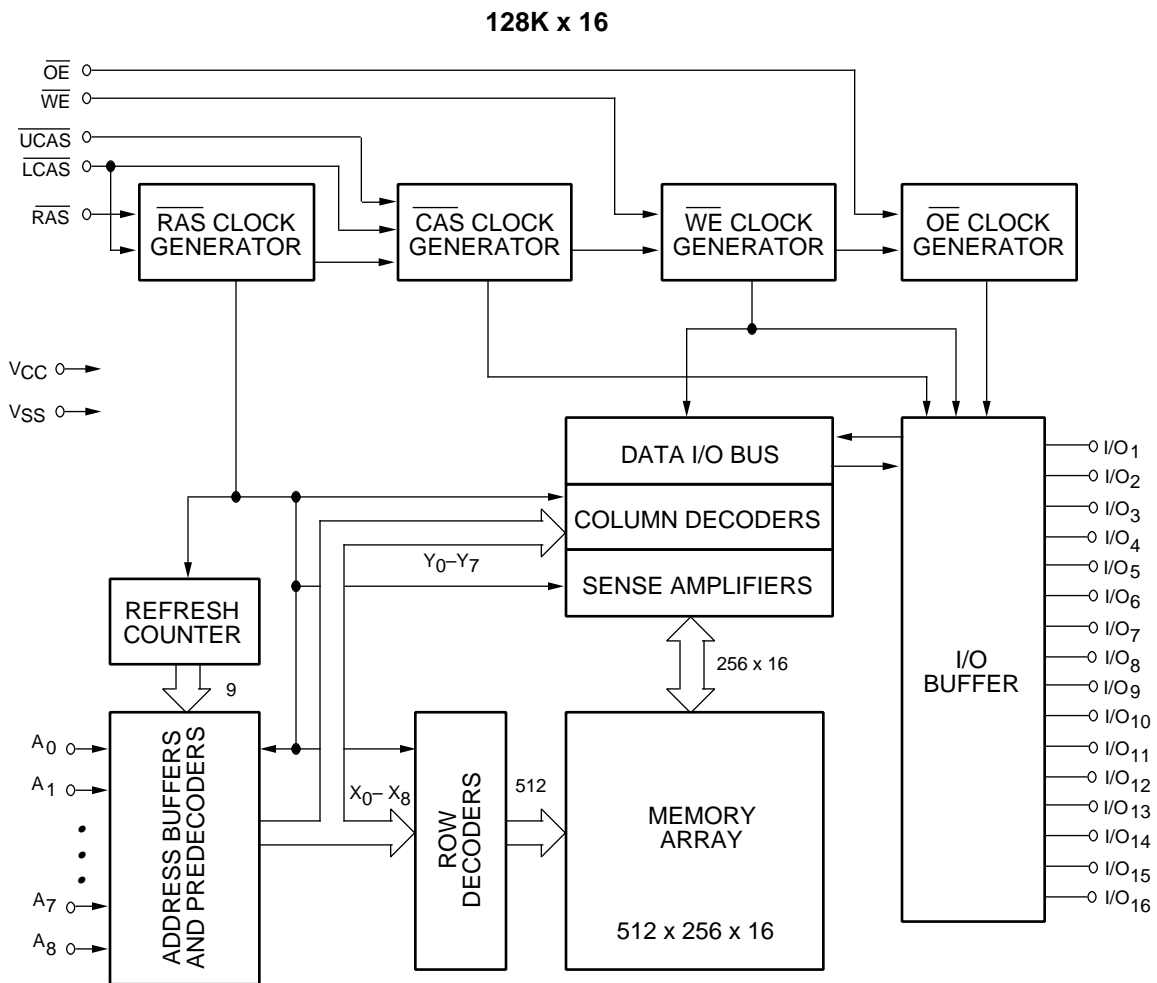

16128H-04

**DC and Operating Characteristics (1-2)**

T<sub>A</sub> = 0°C to 70°C, V<sub>CC</sub> = 5 V ± 10%, V<sub>SS</sub> = 0 V, unless otherwise specified.

Symbol	Parameter	Access Time	V53C16128H			Unit	Test Conditions	Notes
			Min.	Typ.	Max.			
I <sub>LI</sub>	Input Leakage Current (any input pin)		-10		10	μA	V <sub>SS</sub> ≤ V <sub>IN</sub> ≤ V <sub>CC</sub>	
I <sub>LO</sub>	Output Leakage Current (for High-Z State)		-10		10	μA	V <sub>SS</sub> ≤ V <sub>OUT</sub> ≤ V <sub>CC</sub> R <sub>AS</sub> , C <sub>AS</sub> at V <sub>IH</sub>	
I <sub>CC1</sub>	V <sub>CC</sub> Supply Current, Operating	30			200	mA	t <sub>RC</sub> = t <sub>RC</sub> (min.)	1, 2
		35			190			
		40			180			
		45			170			
		50			160			
I <sub>CC2</sub>	V <sub>CC</sub> Supply Current, TTL Standby				2	mA	R <sub>AS</sub> , C <sub>AS</sub> at V <sub>IH</sub> , other inputs ≥ V <sub>SS</sub>	
I <sub>CC3</sub>	V <sub>CC</sub> Supply Current, RAS-Only Refresh	30			200	mA	t <sub>RC</sub> = t <sub>RC</sub> (min.)	2
		35			190			
		40			180			
		45			170			
		50			160			
I <sub>CC4</sub>	V <sub>CC</sub> Supply Current, EDO Page Mode Operation	30			190	mA	Minimum Cycle	1, 2
		35			180			
		40			170			
		45			160			
		50			150			
I <sub>CC5</sub>	V <sub>CC</sub> Supply Current, Standby Output Enable other inputs ≥ V <sub>SS</sub>				2	mA	R <sub>AS</sub> = V <sub>IH</sub> C <sub>AS</sub> = V <sub>IL</sub>	1
I <sub>CC6</sub>	V <sub>CC</sub> Supply Current, CMOS Standby				1	mA	R <sub>AS</sub> ≥ V <sub>CC</sub> - 0.2 V, C <sub>AS</sub> ≥ V <sub>CC</sub> - 0.2 V, All other inputs ≥ V <sub>SS</sub>	
V <sub>CC</sub>	Supply Voltage		4.5	5.0	5.5	V		
V <sub>IL</sub>	Input Low Voltage		-1		0.8	V		3
V <sub>IH</sub>	Input High Voltage		2.4		V <sub>CC</sub> + 1	V		3
V <sub>OL</sub>	Output Low Voltage				0.4	V	I <sub>OL</sub> = 4.2 mA	
V <sub>OH</sub>	Output High Voltage		2.4		2.4	V	I <sub>OH</sub> = -5 mA	

**AC Characteristics**

$T_A = 0^\circ\text{C}$  to  $70^\circ\text{C}$ ,  $V_{CC} = 5\text{ V} \pm 10\%$ ,  $V_{SS} = 0\text{V}$  unless otherwise noted  
 AC Test conditions, input pulse levels 0 to 3V

#	Symbol	Parameter	30		35		40		45		50		Unit	Notes
			Min.	Max.	Min.	Max.	Min.	Max.	Min.	Max.	Min.	Max.		
1	$t_{RAS}$	$\overline{RAS}$ Pulse Width	30	75K	35	75K	40	75K	45	75K	50	75K	ns	
2	$t_{RC}$	Read or Write Cycle Time	65		70		75		80		90		ns	
3	$t_{RP}$	$\overline{RAS}$ Precharge Time	25		25		25		25		30		ns	
4	$t_{CSH}$	$\overline{CAS}$ Hold Time	30		35		40		45		50		ns	
5	$t_{CAS}$	$\overline{CAS}$ Pulse Width	5		6		7		8		9		ns	
6	$t_{RCD}$	$\overline{RAS}$ to $\overline{CAS}$ Delay	15	20	16	24	17	28	18	32	19	36	ns	
7	$t_{RCS}$	Read Command Setup Time	0		0		0		0		0		ns	4
8	$t_{ASR}$	Row Address Setup Time	0		0		0		0		0		ns	
9	$t_{RAH}$	Row Address Hold Time	5		6		7		8		9		ns	
10	$t_{ASC}$	Column Address Setup Time	0		0		0		0		0		ns	
11	$t_{CAH}$	Column Address Hold Time	5		5		5		6		7		ns	
12	$t_{RSH(R)}$	$\overline{RAS}$ Hold Time (Read Cycle)	10		10		10		10		10		ns	
13	$t_{CRP}$	$\overline{CAS}$ to $\overline{RAS}$ Precharge Time	5		5		5		5		5		ns	
14	$t_{RCH}$	Read Command Hold Time Referenced to $\overline{CAS}$	0		0		0		0		0		ns	5
15	$t_{RRH}$	Read Command Hold Time Referenced to $\overline{RAS}$	0		0		0		0		0		ns	5
16	$t_{ROH}$	$\overline{RAS}$ Hold Time Referenced to $\overline{OE}$	6		7		8		9		10		ns	
17	$t_{OAC}$	Access Time from $\overline{OE}$		10		11		12		13		14	ns	12
18	$t_{CAC}$	Access Time from $\overline{CAS}$		10		11		12		13		14	ns	6,7,14
19	$t_{RAC}$	Access Time from $\overline{RAS}$		30		35		40		45		50	ns	6, 8, 9
20	$t_{CAA}$	Access Time from Column Address		16		18		20		22		24	ns	6,7,10
21	$t_{LZ}$	$\overline{OE}$ or $\overline{CAS}$ to Low-Z Output	0		0		0		0		0		ns	16
22	$t_{HZ}$	$\overline{OE}$ or $\overline{CAS}$ to High-Z Output	0	5	0	6	0	6	0	7	0	8	ns	16
23	$t_{AR}$	Column Address Hold Time from $\overline{RAS}$	26		28		30		35		40		ns	
24	$t_{RAD}$	$\overline{RAS}$ to Column Address Delay Time	10	14	11	17	12	20	13	23	14	26	ns	11
25	$t_{RSH(W)}$	$\overline{RAS}$ or $\overline{CAS}$ Hold Time in Write Cycle	10		10		10		10		10		ns	
26	$t_{CWL}$	Write Command to $\overline{CAS}$ Lead Time	10		11		12		13		14		ns	
27	$t_{WCS}$	Write Command Setup Time	0		0		0		0		0		ns	12, 13
28	$t_{WCH}$	Write Command Hold Time	5		5		5		6		7		ns	
29	$t_{WP}$	Write Pulse Width	5		5		5		6		7		ns	

## AC Characteristics (Cont'd)

#	Symbol	Parameter	30		35		40		45		50		Unit	Notes
			Min.	Max.	Min.	Max.	Min.	Max.	Min.	Max.	Min.	Max.		
30	$t_{WCR}$	Write Command Hold Time from $\overline{RAS}$	26		28		30		35		40		ns	
31	$t_{RWL}$	Write Command to $\overline{RAS}$ Lead Time	10		11		12		13		14		ns	
32	$t_{DS}$	Data in Setup Time	0		0		0		0		0		ns	14
33	$t_{DH}$	Data in Hold Time	5		5		5		6		7		ns	14
34	$t_{WOH}$	Write to $\overline{OE}$ Hold Time	5		5		6		7		8		ns	14
35	$t_{OED}$	$\overline{OE}$ to Data Delay Time	5		5		6		7		8		ns	14
36	$t_{RWC}$	Read-Modify-Write Cycle Time	100		105		110		115		130		ns	
37	$t_{RRW}$	Read-Modify-Write Cycle $\overline{RAS}$ Pulse Width	65		70		75		80		87		ns	
38	$t_{CWD}$	$\overline{CAS}$ to $\overline{WE}$ Delay	26		28		30		32		34		ns	12
39	$t_{RWD}$	$\overline{RAS}$ to $\overline{WE}$ Delay in Read-Modify-Write Cycle	50		54		58		62		68		ns	12
40	$t_{CRW}$	$\overline{CAS}$ Pulse Width (RMW)	44		46		48		50		52		ns	
41	$t_{AWD}$	Col. Address to $\overline{WE}$ Delay	32		35		38		41		42		ns	12
42	$t_{PC}$	EDO Page Mode Read or Write Cycle Time	12		14		15		17		19		ns	
43	$t_{CP}$	$\overline{CAS}$ Precharge Time	3		4		5		6		7		ns	
44	$t_{CAR}$	Column Address to $\overline{RAS}$ Setup Time	16		18		20		22		24		ns	
45	$t_{CAP}$	Access Time from Column Precharge		19		21		23		25		27	ns	7
46	$t_{DHR}$	Data in Hold Time Referenced to $\overline{RAS}$	26		28		30		35		40		ns	
47	$t_{CSR}$	$\overline{CAS}$ Setup Time $\overline{CAS}$ - before- $\overline{RAS}$ Refresh	10		10		10		10		10		ns	
48	$t_{RPC}$	$\overline{RAS}$ to $\overline{CAS}$ Precharge Time	0		0		0		0		0		ns	
49	$t_{CHR}$	$\overline{CAS}$ Hold Time $\overline{CAS}$ -before- $\overline{RAS}$ Refresh	7		8		8		10		12		ns	
50	$t_{PCM}$	EDO Page Mode Read-Modify-Write Cycle Time	56		58		60		65		70		ns	
51	$t_{COH}$	Output Hold After $\overline{CAS}$ Low	5		5		5		5		5		ns	
52	$t_{OES}$	$\overline{OE}$ Low to $\overline{CAS}$ HIGH Setup Time	5		5		5		5		5		ns	
53	$t_{OEH}$	$\overline{OE}$ Hold Time from $\overline{WE}$ during Read-Modify Write Cycle	10		10		10		10		10		ns	
54	$t_{OEP}$	$\overline{OE}$ High Pulse Width	10		10		10		10		10		ns	
55	$t_T$	Transition Time (Rise and Fall)	1.5	50	1.5	50	1.5	50	1.5	50	1.5	50	ns	15
56	$t_{REF}$	Refresh Interval (512 Cycles)		8		8		8		8		8	ms	17

**Notes:**

1.  $I_{CC}$  is dependent on output loading when the device output is selected. Specified  $I_{CC}$  (max.) is measured with the output open.
2.  $I_{CC}$  is dependent upon the number of address transitions. Specified  $I_{CC}$  (max.) is measured with a maximum of two transitions per address cycle in EDO Page Mode.
3. Specified  $V_{IL}$  (min.) is steady state operating. During transitions,  $V_{IL}$  (min.) may undershoot to  $-1.0$  V for a period not to exceed 20 ns. All AC parameters are measured with  $V_{IL}$  (min.)  $\geq V_{SS}$  and  $V_{IH}$  (max.)  $\leq V_{CC}$ .
4.  $t_{RCD}$  (max.) is specified for reference only. Operation within  $t_{RCD}$  (max.) limits insures that  $t_{RAC}$  (max.) and  $t_{CAA}$  (max.) can be met. If  $t_{RCD}$  is greater than the specified  $t_{RCD}$  (max.), the access time is controlled by  $t_{CAA}$  and  $t_{CAC}$ .
5. Either  $t_{RRH}$  or  $t_{RCH}$  must be satisfied for a Read Cycle to occur.
6. Measured with a load equivalent to one TTL input and 100 pF.
7. Access time is determined by the longest of  $t_{CAA}$ ,  $t_{CAC}$  and  $t_{CAP}$ .
8. Assumes that  $t_{RAD} \leq t_{RAD}$  (max.). If  $t_{RAD}$  is greater than  $t_{RAD}$  (max.),  $t_{RAC}$  will increase by the amount that  $t_{RAD}$  exceeds  $t_{RAD}$  (max.).
9. Assumes that  $t_{RCD} \leq t_{RCD}$  (max.). If  $t_{RCD}$  is greater than  $t_{RCD}$  (max.),  $t_{RAC}$  will increase by the amount that  $t_{RCD}$  exceeds  $t_{RCD}$  (max.).
10. Assumes that  $t_{RAD} \geq t_{RAD}$  (max.).
11. Operation within the  $t_{RAD}$  (max.) limit ensures that  $t_{RAC}$  (max.) can be met.  $t_{RAD}$  (max.) is specified as a reference point only. If  $t_{RAD}$  is greater than the specified  $t_{RAD}$  (max.) limit, the access time is controlled by  $t_{CAA}$  and  $t_{CAC}$ .
12.  $t_{WCS}$ ,  $t_{RWD}$ ,  $t_{AWD}$  and  $t_{CWD}$  are not restrictive operating parameters.
13.  $t_{WCS}$  (min.) must be satisfied in an Early Write Cycle.
14.  $t_{DS}$  and  $t_{DH}$  are referenced to the latter occurrence of  $\overline{CAS}$  or  $\overline{WE}$ .
15.  $t_T$  is measured between  $V_{IH}$  (min.) and  $V_{IL}$  (max.). AC-measurements assume  $t_T = 3$  ns.
16. Assumes a three-state test load (5 pF and a 380 Ohm Thevenin equivalent).
17. An initial 200  $\mu$ s pause and 8  $\overline{RAS}$ -containing cycles are required when exiting an extended period of bias without clocks. An extended period of time without clocks is defined as one that exceeds the specified Refresh Interval.

**Truth Table**

Function	RAS	LCAS	UCAS	WE	OE	ADDRESS	I/O	Notes
Standby	H	H	H	X	X		High-Z	
Read: Word	L	L	L	H	L	ROW/COL	Data Out	
Read: Lower Byte	L	L	H	H	L	ROW/COL	Lower Byte, Data-Out Upper Byte, High-Z	
Read: Upper Byte	L	H	L	H	L	ROW/COL	Lower Byte, High-Z Upper Byte, Data-Out	
Write: Word (Early-Write)	L	L	L	L	X	ROW/COL	Data-In	
Write: Lower Byte (Early)	L	L	H	L	X	ROW/COL	Lower Byte, Data-In Upper Byte, High-Z	
Read: Upper Byte (Early)	L	H	L	L	X	ROW/COL	Lower Byte, High-Z Upper Byte, Data-In	
Read-Write	L	L	L	H→L	L→H	ROW/COL	Data-Out, Data-In	1, 2
EDO Page-Mode Read	L	H→L	H→L	H	L	COL	Data-Out	2
EDO Page-Mode Write	L	H→L	H→L	L	X	COL	Data-In	2
EDO Page-Mode Read-Write	L	H→L	H→L	H→L	L→H	COL	Data-Out, Data-In	1, 2
Hidden Refresh Read	L→H→L	L	L	H	L	ROW/COL	Data-Out	2
RAS-Only Refresh	L	H	H	X	X	ROW	High-Z	
CBR Refresh	H→L	L	L	X	X		High-Z	3

**Notes:**

1. Byte Write cycles  $\overline{\text{LCAS}}$  or  $\overline{\text{UCAS}}$  active.
2. Byte Read cycles  $\overline{\text{LCAS}}$  or  $\overline{\text{UCAS}}$  active.
3. Only one of the two  $\overline{\text{CAS}}$  must be active ( $\overline{\text{LCAS}}$  or  $\overline{\text{UCAS}}$ ).



Waveforms of Read Cycle

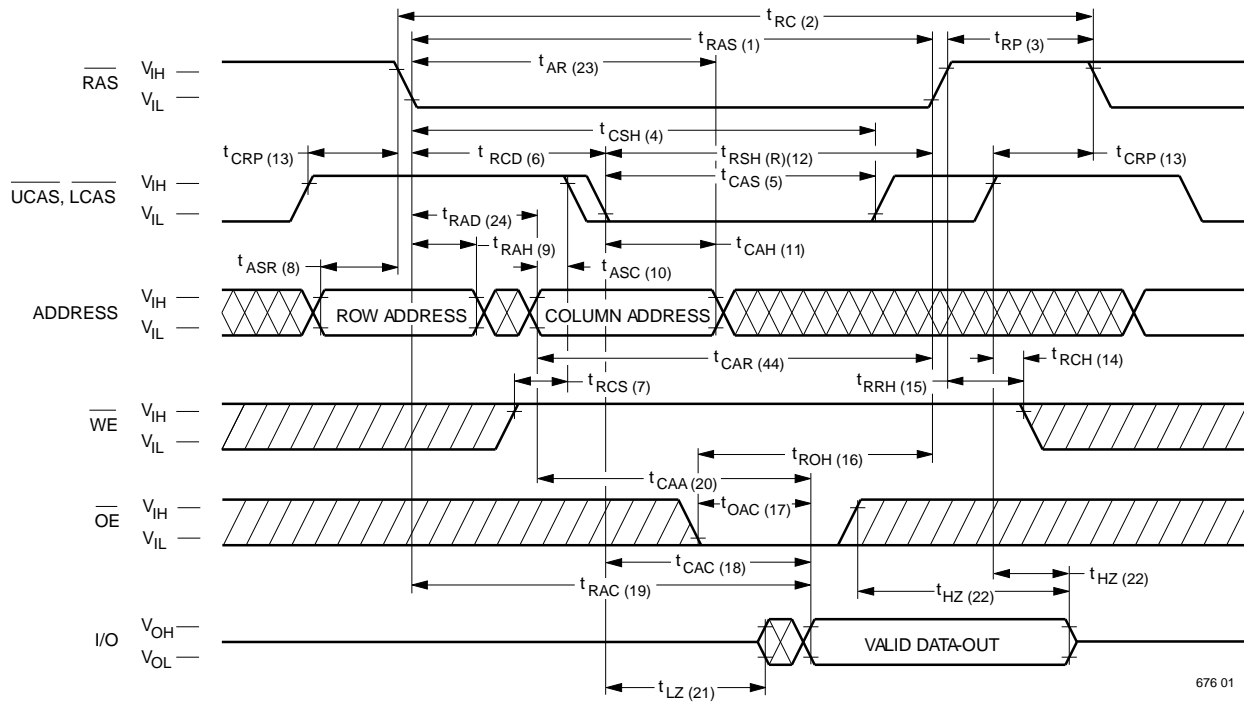

676 01

Waveforms of Early Write Cycle

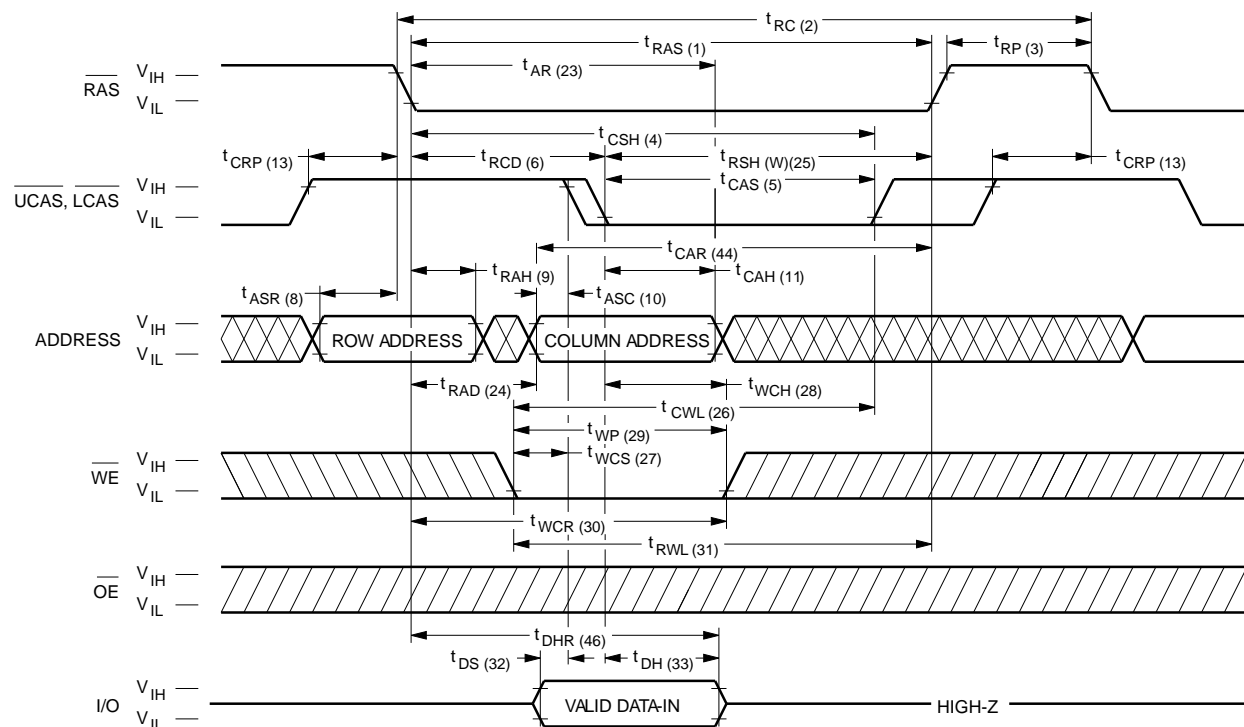

16128H-06

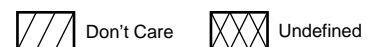

Waveforms of  $\overline{OE}$ -Controlled Write Cycle

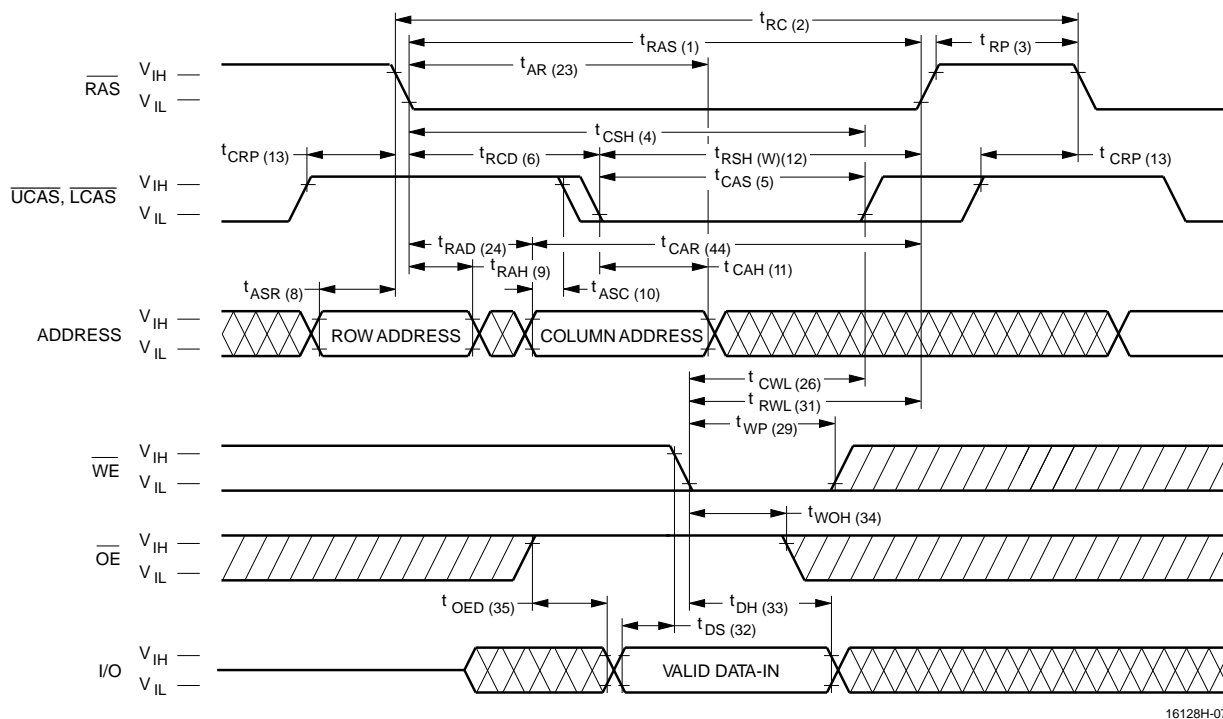

16128H-07

Waveforms of Read-Modify-Write Cycle

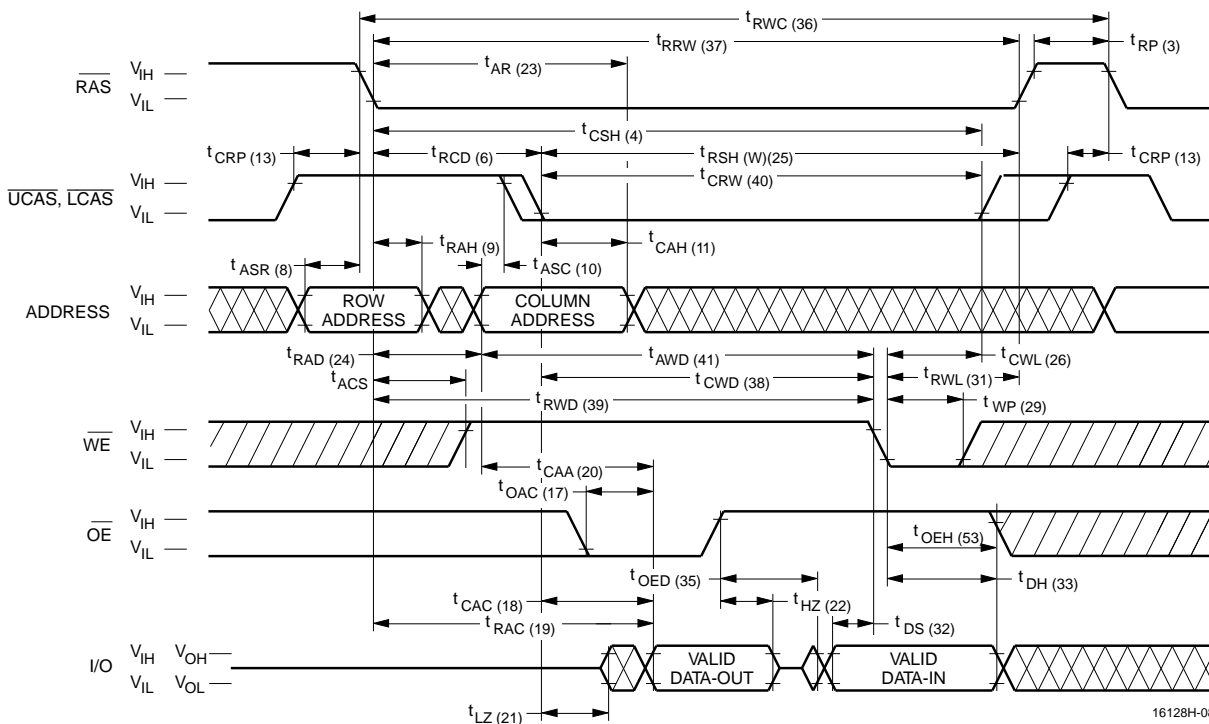

16128H-08

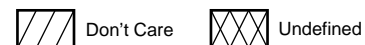

Waveforms of EDO Page Mode Read Cycle

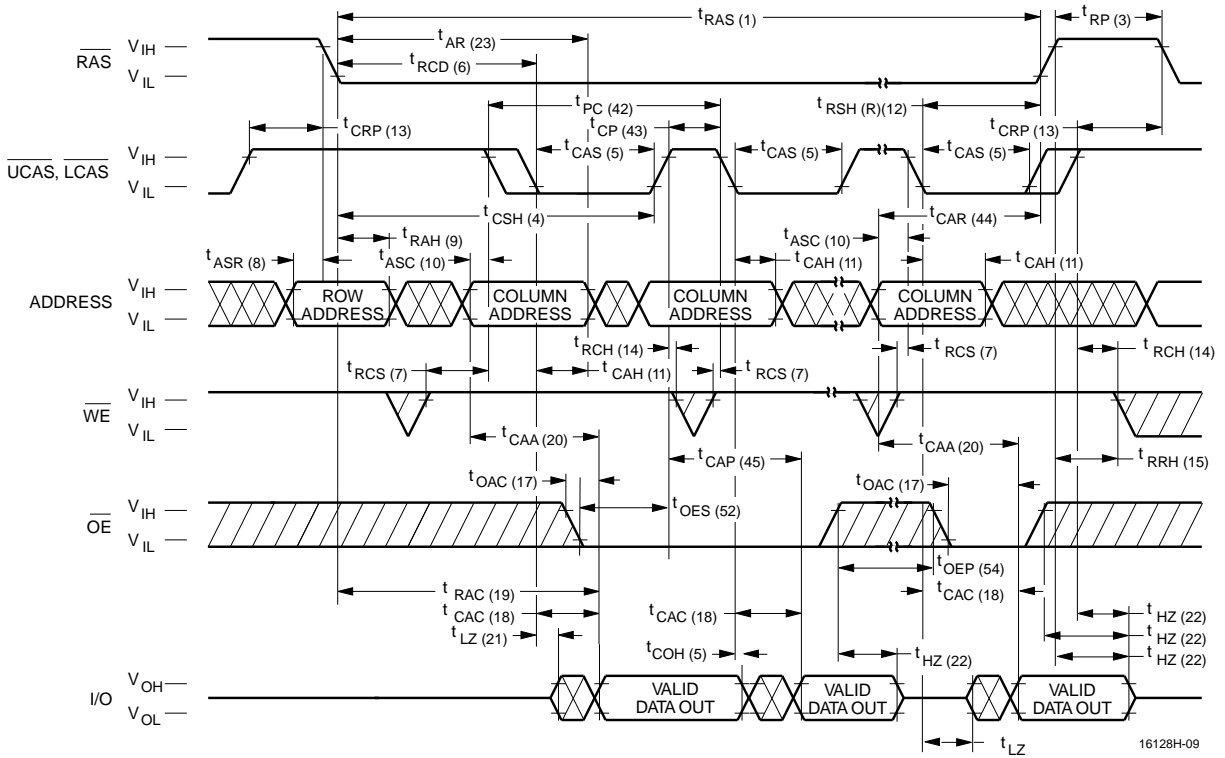

Waveforms of EDO Page Mode Write Cycle

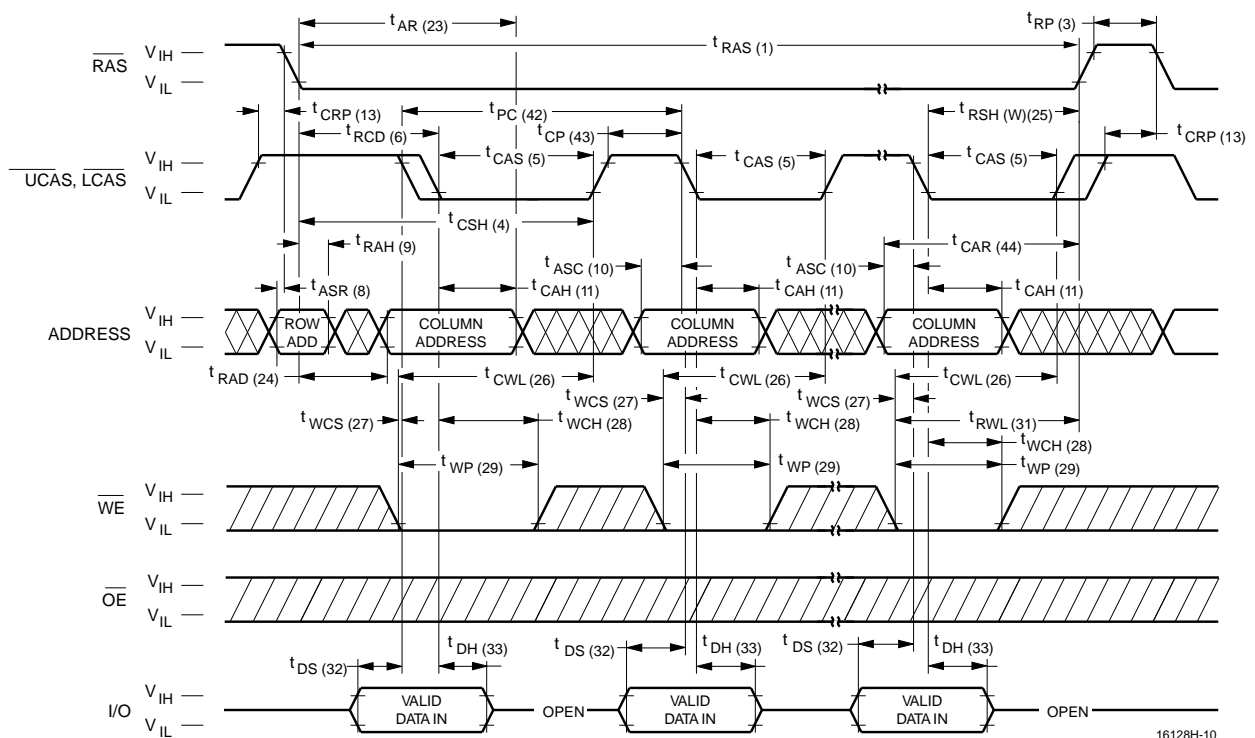

Don't Care Undefined

Waveforms of EDO Page Mode Read-Write Cycle

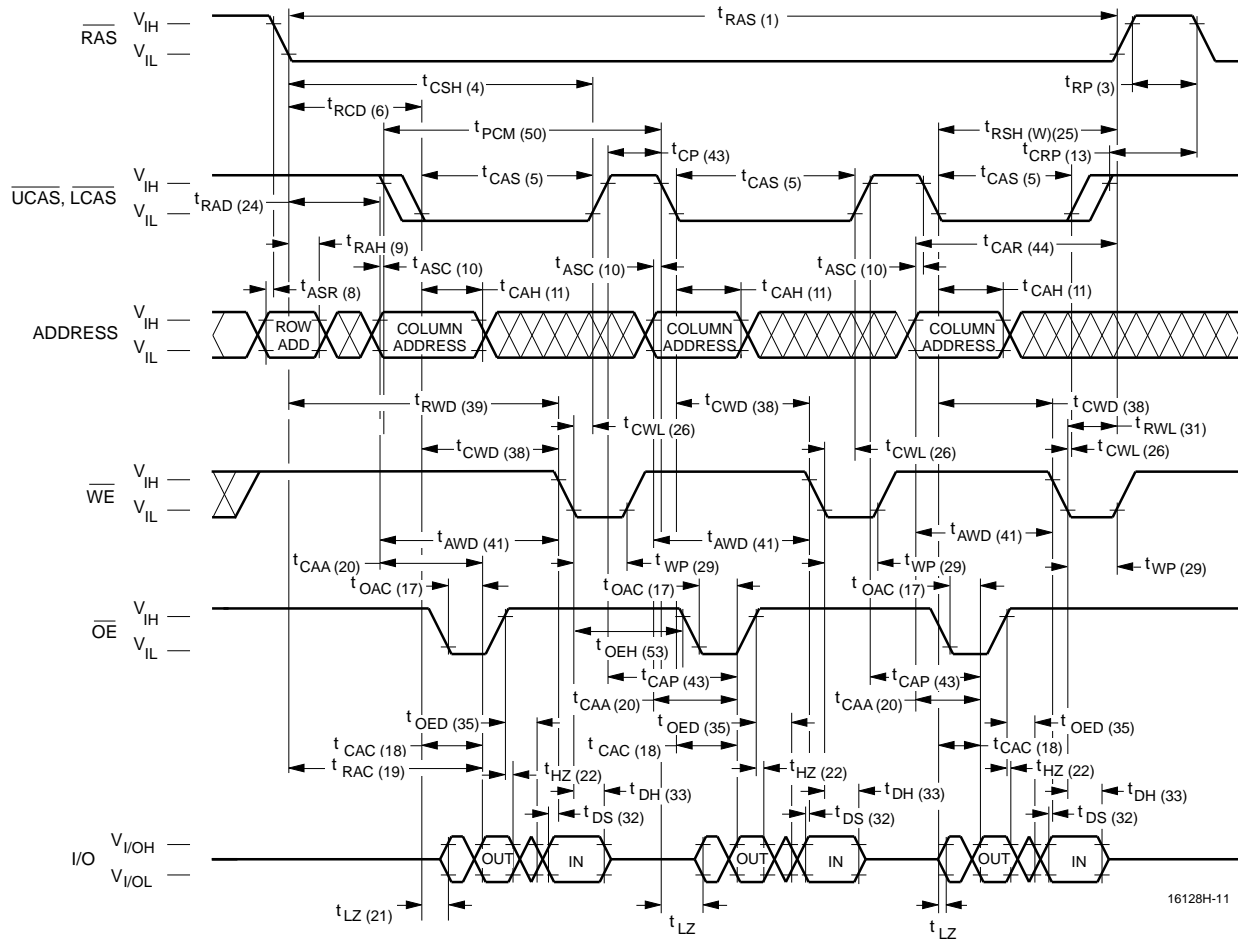

16128H-11

Waveforms of  $\overline{RAS}$ -Only Refresh Cycle

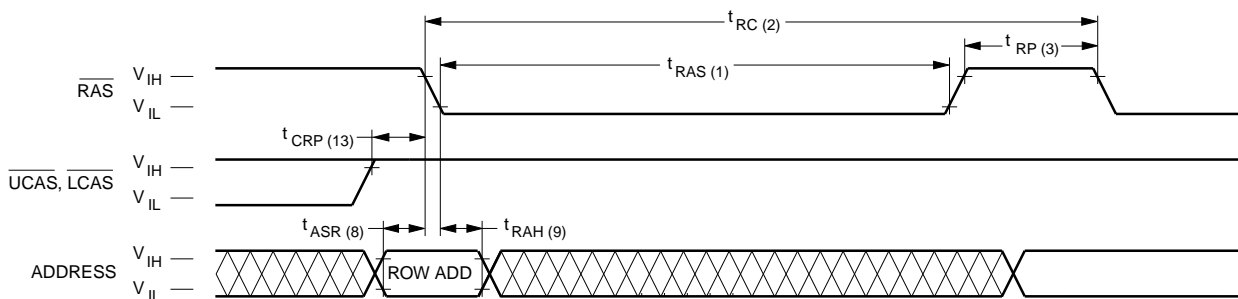

16128H-12

NOTE:  $\overline{WE}$ ,  $\overline{OE}$  = Don't care

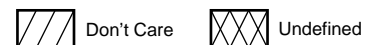

Waveforms of  $\overline{\text{CAS}}$ -before- $\overline{\text{RAS}}$  Refresh Counter Test Cycle

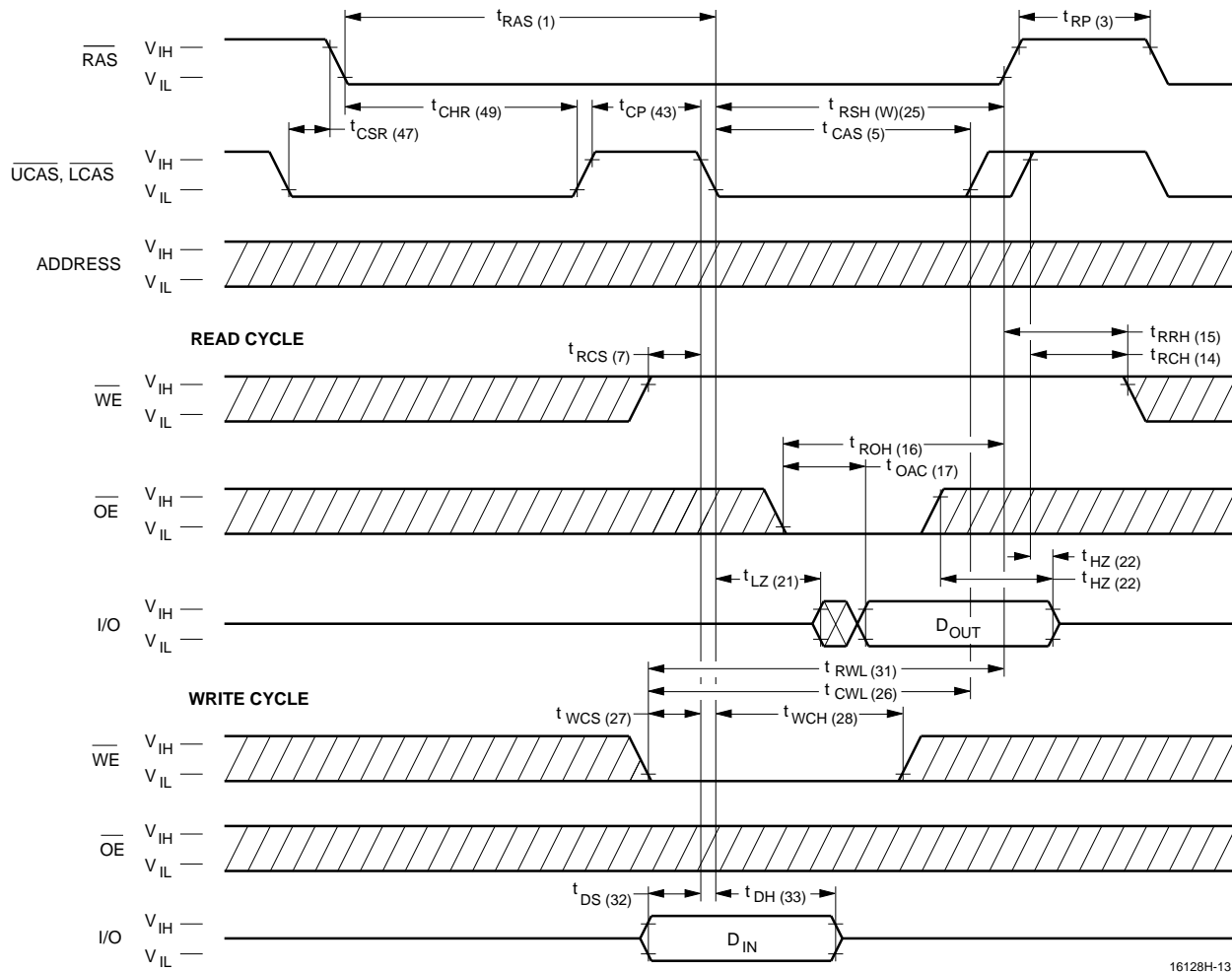

16128H-13

Waveforms of  $\overline{\text{CAS}}$ -before- $\overline{\text{RAS}}$  Refresh Cycle

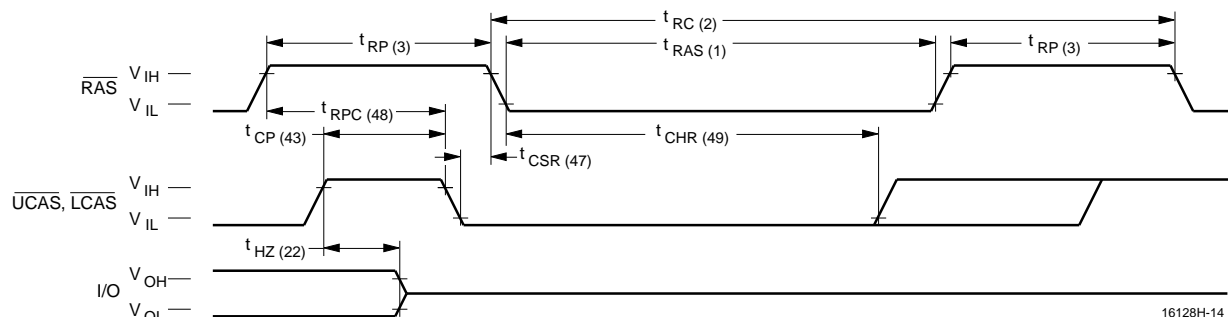

16128H-14

NOTE:  $\overline{\text{WE}}$ ,  $\overline{\text{OE}}$ ,  $A_0$ - $A_8$  = Don't care

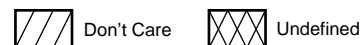

**Waveforms of Hidden Refresh Cycle (Read)**

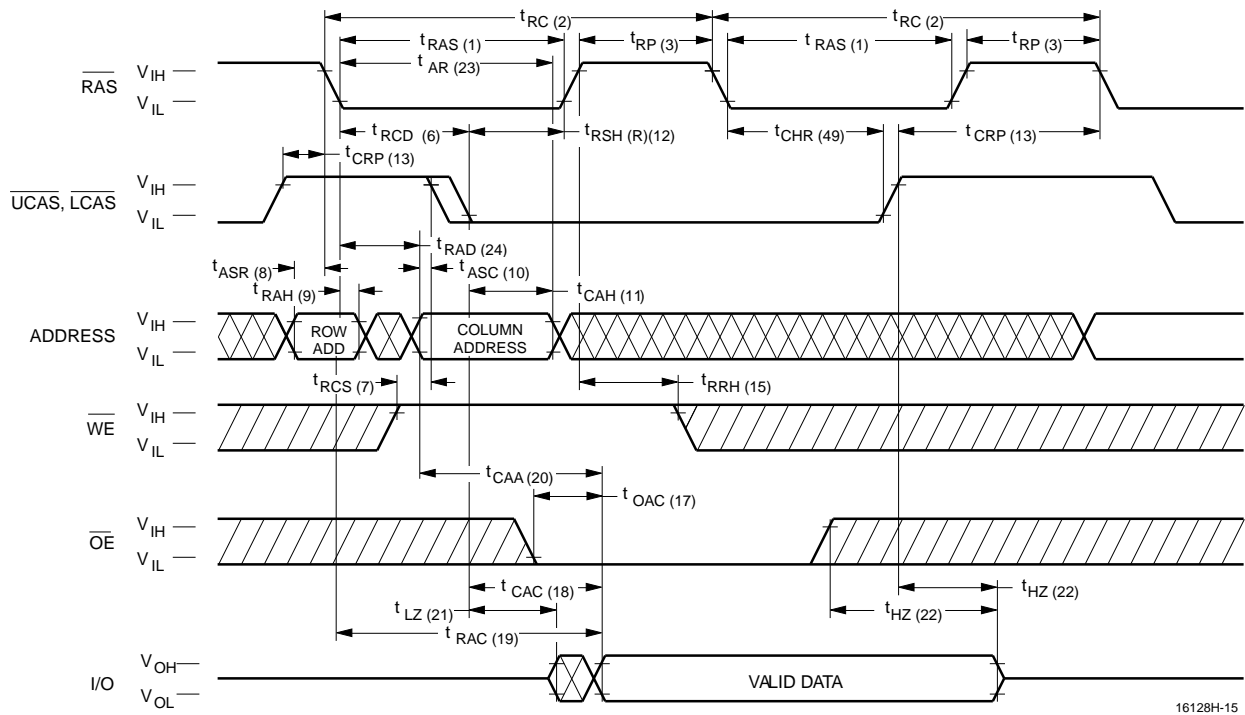

**Waveforms of Hidden Refresh Cycle (Write)**

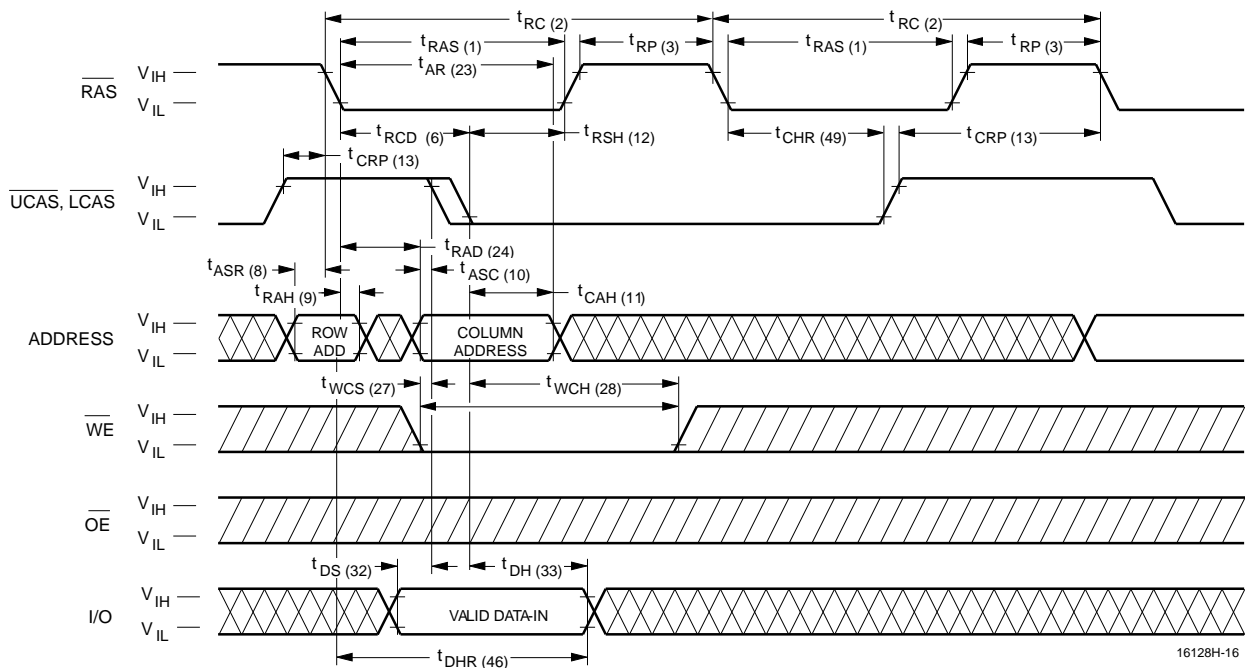

Don't Care Undefined

**Waveforms of EDO Page Mode Read-Early-Write Cycle (Pseudo Read-Modify-Write)**

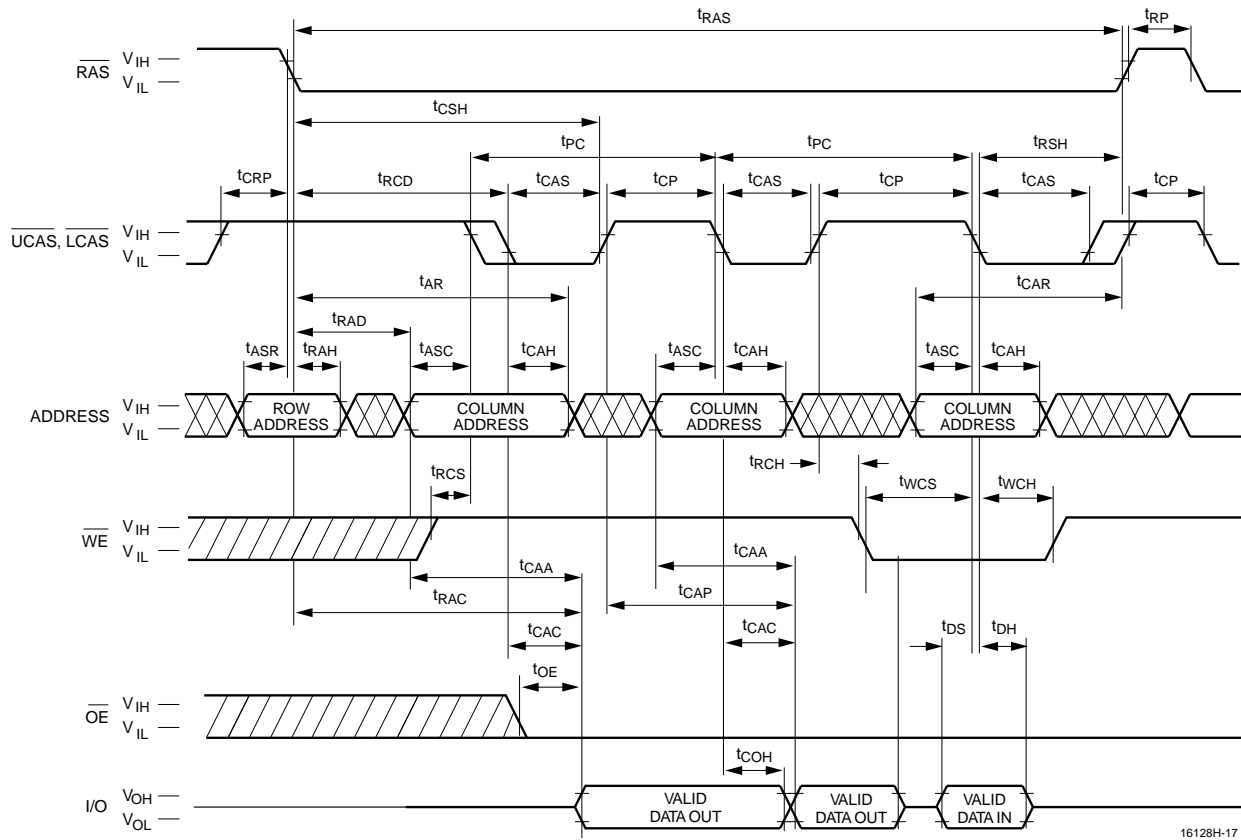

16128H-17

### Functional Description

The V53C16128H is a CMOS dynamic RAM optimized for high data bandwidth, low power applications. It is functionally similar to a traditional dynamic RAM. The V53C16128H reads and writes data by multiplexing an 17-bit address into a 9-bit row and a 8-bit column address. The row address is latched by the Row Address Strobe ( $\overline{RAS}$ ). The column address “flows through” an internal address buffer and is latched by the Column Address Strobe ( $\overline{CAS}$ ). Because access time is primarily dependent on a valid column address rather than the precise time that the  $\overline{CAS}$  edge occurs, the delay time from  $\overline{RAS}$  to  $\overline{CAS}$  has little effect on the access time.

### Memory Cycle

A memory cycle is initiated by bringing  $\overline{RAS}$  low. Any memory cycle, once initiated, must not be ended or aborted before the minimum  $t_{RAS}$  time has expired. This ensures proper device operation and data integrity. A new cycle must not be initiated until the minimum precharge time  $t_{RP}/t_{CP}$  has elapsed.

### Read Cycle

A Read cycle is performed by holding the Write Enable ( $\overline{WE}$ ) signal High during a  $\overline{RAS}/\overline{CAS}$  operation. The column address must be held for a minimum specified by  $t_{AR}$ . Data Out becomes valid only when  $t_{OAC}$ ,  $t_{RAC}$ ,  $t_{CAA}$  and  $t_{CAC}$  are all satisfied. As a result, the access time is dependent on the timing relationships between these parameters. For example, the access time is limited by  $t_{CAA}$  when  $t_{RAC}$ ,  $t_{CAC}$  and  $t_{OAC}$  are all satisfied.

### Write Cycle

A Write Cycle is performed by taking  $\overline{WE}$  and  $\overline{CAS}$  low during a  $\overline{RAS}$  operation. The column address is latched by  $\overline{CAS}$ . The Write Cycle can be  $\overline{WE}$  controlled or  $\overline{CAS}$  controlled depending on whether  $\overline{WE}$  or  $\overline{CAS}$  falls later. Consequently, the input data must be valid at or before the falling edge of  $\overline{WE}$  or  $\overline{CAS}$ , whichever occurs last. In the  $\overline{CAS}$ -controlled Write Cycle, when the leading edge of  $\overline{WE}$  occurs prior to the  $\overline{CAS}$  low transition, the I/O data pins will be in the High-Z state at the beginning of the Write function. Ending the Write with  $\overline{RAS}$  or  $\overline{CAS}$  will maintain the output in the High-Z state.

In the  $\overline{WE}$  controlled Write Cycle,  $\overline{OE}$  must be in the high state and  $t_{OED}$  must be satisfied.

### Extended Data Output Page Mode

EDO Page operation permits all 512 columns within a selected row of the device to be randomly accessed at a high data rate. Maintaining  $\overline{RAS}$  low while performing successive  $\overline{CAS}$  cycles retains the row address internally and eliminates the need to reapply it for each cycle. The column address buffer acts as a transparent or flow-through latch while  $\overline{CAS}$  is high. Thus, access begins from the occurrence of a valid column address rather than from the falling edge of  $\overline{CAS}$ , eliminating  $t_{ASC}$  and  $t_T$  from the critical timing path.  $\overline{CAS}$  latches the address into the column address buffer. During EDO operation, Read, Write, Read-Modify-Write or Read-Write-Read cycles are possible at random addresses within a row. Following the initial entry cycle into Hyper Page Mode, access is  $t_{CAA}$  or  $t_{CAP}$  controlled. If the column address is valid prior to the rising edge of  $\overline{CAS}$ , the access time is referenced to the  $\overline{CAS}$  rising edge and is specified by  $t_{CAP}$ . If the column address is valid after the rising  $\overline{CAS}$  edge, access is timed from the occurrence of a valid address and is specified by  $t_{CAA}$ . In both cases, the falling edge of  $\overline{CAS}$  latches the address and enables the output.

EDO provides a sustained data rate of 83 MHz for applications that require high data rates such as bit-mapped graphics or high-speed signal processing. The following equation can be used to calculate the maximum data rate:

$$\text{Data Rate} = \frac{512}{t_{RC} \times 511 \times t_{PC}}$$

### Data Output Operation

The V53C16128H Input/Output is controlled by  $\overline{OE}$ ,  $\overline{CAS}$ ,  $\overline{WE}$  and  $\overline{RAS}$ . A  $\overline{RAS}$  low transition enables the transfer of data to and from the selected row address in the Memory Array. A  $\overline{RAS}$  high transition disables data transfer and latches the output data if the output is enabled. After a memory cycle is initiated with a  $\overline{RAS}$  low transition, a  $\overline{CAS}$  low transition or  $\overline{CAS}$  low level enables the internal I/O path. A  $\overline{CAS}$  high transition or a  $\overline{CAS}$  high level disables the I/O path and the output driver if it is enabled. A  $\overline{CAS}$  low transition while  $\overline{RAS}$  is high has no effect on the I/O data path or on the output drivers. The output drivers, when otherwise enabled, can be disabled by holding  $\overline{OE}$  high. The  $\overline{OE}$  signal has no effect on any data stored in the output latches. A  $\overline{WE}$  low level can also disable the output drivers when  $\overline{CAS}$  is low.



During a Write cycle, if  $\overline{WE}$  goes low at a time in relationship to  $\overline{CAS}$  that would normally cause the outputs to be active, it is necessary to use  $\overline{OE}$  to disable the output drivers prior to the  $\overline{WE}$  low transition to allow Data In Setup Time ( $t_{DS}$ ) to be satisfied.

**Power-On**

After application of the  $V_{CC}$  supply, an initial pause of 200  $\mu s$  is required followed by a minimum of 8 initialization cycles (any combination of cycles containing a  $\overline{RAS}$  clock). Eight initialization cycles are required after extended periods of bias without clocks (greater than the Refresh Interval).

During Power-On, the  $V_{CC}$  current requirement of the V53C16128H is dependent on the input levels of  $\overline{RAS}$  and  $\overline{CAS}$ . If  $\overline{RAS}$  is low during Power-On, the device will go into an active cycle and  $I_{CC}$  will exhibit current transients. It is recommended that  $\overline{RAS}$  and  $\overline{CAS}$  track with  $V_{CC}$  or be held at a valid  $V_{IH}$  during Power-On to avoid current surges.

**Table 1. V53C16128H Data Output Operation for Various Cycle Types**

<b>Cycle Type</b>	<b>I/O State</b>
Read Cycles	Data from Addressed Memory Cell
$\overline{CAS}$ -Controlled Write Cycle (Early Write)	High-Z
$\overline{WE}$ -Controlled Write Cycle (Late Write)	$\overline{OE}$ Controlled. High $\overline{OE}$ = High-Z I/Os
Read-Modify-Write Cycles	Data from Addressed Memory Cell
EDO Page Mode Read	Data from Addressed Memory Cell
EDO Page Mode Write Cycle (Early Write)	High-Z
EDO Page Mode Read-Modify-Write Cycle	Data from Addressed Memory Cell
$\overline{RAS}$ -only Refresh	High-Z
$\overline{CAS}$ -before- $\overline{RAS}$ Refresh Cycle	Data remains as in previous cycle
$\overline{CAS}$ -only Cycles	High-Z

**Package Outlines**

**40-Pin Plastic SOJ**

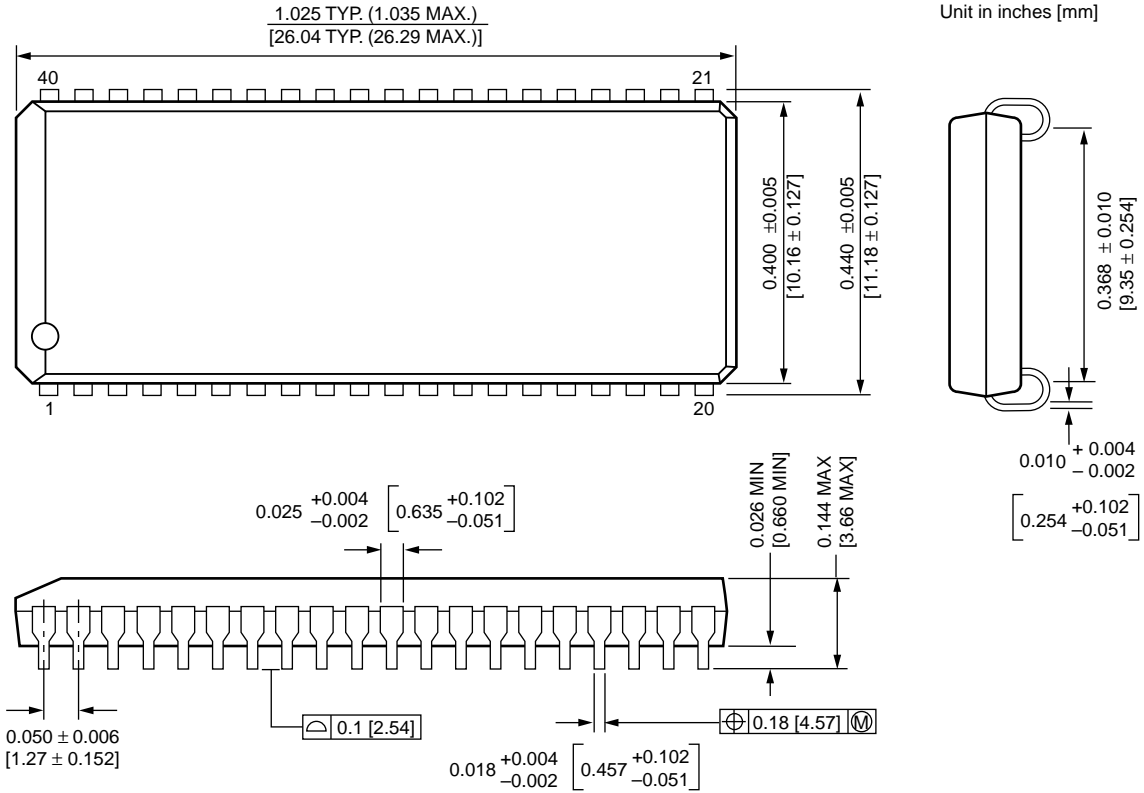

**40/44L-Pin TSOP-II**

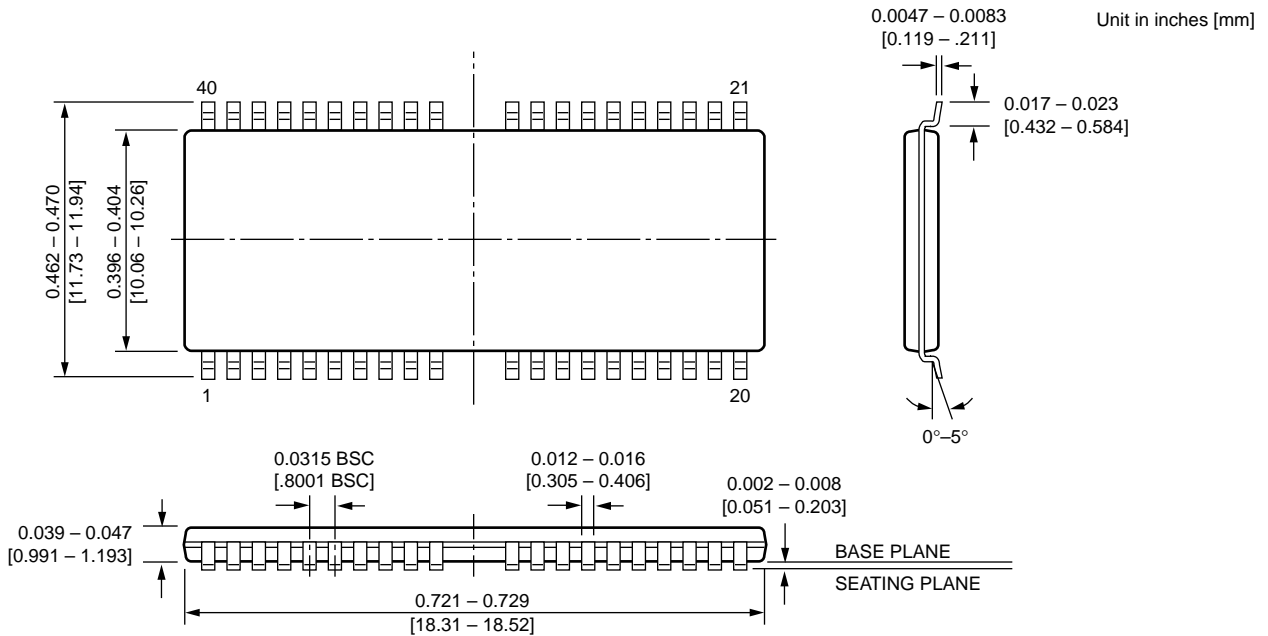



**U.S.A.**

3910 NORTH FIRST STREET  
SAN JOSE, CA 95134  
PHONE: 408-433-6000  
FAX: 408-433-0185

**TAIWAN**

7F, NO. 102  
MIN-CHUAN E. ROAD, SEC. 3  
TAIPEI  
PHONE: 011-886-2-545-1213  
FAX: 011-886-2-545-1209

**JAPAN**

RM.302 ANNEX-G  
HIGASHI-NAKANO  
NAKANO-KU, TOKYO 164  
PHONE: 011-81-03-3365-2851  
FAX: 011-81-03-3365-2836

**HONG KONG**

19 DAI FU STREET  
TAIPO INDUSTRIAL ESTATE  
TAIPO, NT, HONG KONG  
PHONE: 011-852-665-4883  
FAX: 011-852-664-7535

1 CREATION ROAD I  
SCIENCE BASED IND. PARK  
HSIN CHU, TAIWAN, R.O.C.  
PHONE: 011-886-35-783344  
FAX: 011-886-35-792838

**NORTHWESTERN**

3910 NORTH FIRST STREET  
SAN JOSE, CA 95134  
PHONE: 408-433-6000  
FAX: 408-433-0185

**SOUTHWESTERN**

SUITE 200  
5150 E. PACIFIC COAST HWY.  
LONG BEACH, CA 90804  
PHONE: 310-498-3314  
FAX: 310-597-2174

**CENTRAL & SOUTHEASTERN**

604 FIELDWOOD CIRCLE  
RICHARDSON, TX 75081  
PHONE: 972-690-1402  
FAX: 972-690-0341

**NORTHEASTERN**

SUITE 436  
20 TRAFALGAR SQUARE  
NASHUA, NH 03063  
PHONE: 603-889-4393  
FAX: 603-889-9347

---

The information in this document is subject to change without notice.

MOSEL VITELIC makes no commitment to update or keep current the information contained in this document. No part of this document may be copied or reproduced in any form or by any means without the prior written consent of MOSEL-VITELIC.

MOSEL VITELIC subjects its products to normal quality control sampling techniques which are intended to provide an assurance of high quality products suitable for usual commercial applications. MOSEL VITELIC does not do testing appropriate to provide 100% product quality assurance and does not assume any liability for consequential or incidental arising from any use of its products. If such products are to be used in applications in which personal injury might occur from failure, purchaser must do its own quality assurance testing appropriate to such applications.