



VG112

PCS/UMTS-band Variable Gain Amplifier

The Communications Edge™

Product Information

Product Features

- 1800 – 2200 MHz bandwidth
- 25 dB Gain at 1.9 GHz
- 28 dB Attenuation Range
- +46 dBm Output IP3
- +30 dBm P1dB
- Constant IP3 & P1dB over attenuation range
- +5V Single voltage supply
- Pb-free / green / RoHS-compliant 6x6 mm QFN package
- MTTF > 100 years

Applications

- Xmit & Rcv AGC circuitry for mobile infrastructure

Product Description

The VG112 is a PCS / UMTS-band high dynamic range variable gain amplifier (VGA) housed in a low profile Pb-free / green / RoHS-compliant surface-mount leadless QFN package that measures 6 x 6 mm square.

The +30 dBm output compression point and +46 dBm output intercept point of the amplifier are maintained over the entire attenuation range, making the VG112 ideal for use in transmitter and receiver AGC circuits. The high gain of the dual-stage amplifier allows for more integration in a transceiver board while requiring minimal printed circuit board space.

Superior thermal design allows the product to have a minimum MTTF rating of 100 years at a mounting temperature of +85 °C. All devices are 100% RF & DC tested and packaged on tape and reel for automated surface-mount assembly.

Functional Diagram

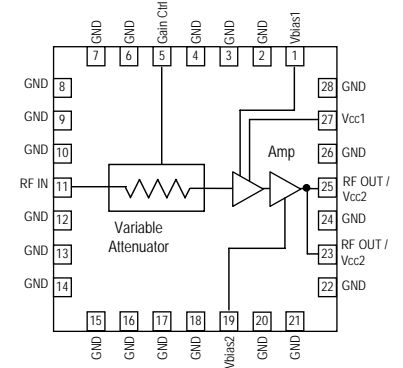

Specifications ⁽¹⁾

Parameter	Units	Min	Typ	Max	Conditions
Operational Bandwidth	MHz	1800		2200	
Test Frequency	MHz		2140		See note 1
Gain at min. attenuation	dB	20.5	23		
Input Return Loss	dB		18		
Output Return Loss	dB		8.2		
Output P1dB	dBm		+30		
Output IP3	dBm	+43	+46		See note 2
Noise Figure at min. attenuation	dB		8		V _{CTRL} = 0 V
Gain Variation Range	dB	23.5	28		See note 3
Gain Variation Control Voltage, V _{CTRL}	V	0		4.5	See note 1
Supply Voltage, V _{CC}	V		+5		
Operating Amplifier Current Range	mA	350	415	475	Pin 25
Gain Control Pin Current	mA			20	V _{CTRL} = 4.5 V. See note 1.

1. Test conditions unless otherwise noted: 25 °C, V_{CC} = +5 V in a tuned application circuit. V_{ctrl} is the control voltage through a 220 Ω dropping resistor as shown in the same application circuit.
 2. 3OIP measured with two tones at an output power of +15 dBm/tone separated by 1 MHz. The suppression on the largest IM3 product is used to calculate the 3OIP using a 2:1 rule.
 3. The gain variation range is measured as the difference in gain with V_{ctrl} = 0V and V_{ctrl} = 4.5V at 2.14 GHz.

Absolute Maximum Rating

Parameter	Rating
Operating Case Temperature	-40 to +85 °C
Storage Temperature	-55 to +125 °C
Pin 5 (Gain Control) Current	30 mA
Junction Temperature	+250 °C

Operation of this device above any of these parameters may cause permanent damage.

Ordering Information

Part No.	Description
VG112-G	PCS/UMTS-band Variable Gain Amplifier (lead-free/green/RoHS-compliant QFN package)
VG112-PCB	2140 MHz Fully Assembled Application Board

Specifications and information are subject to change without notice



2140 MHz Application Circuit Performance Performance using the circuitry on the VG112-PCB Evaluation Board

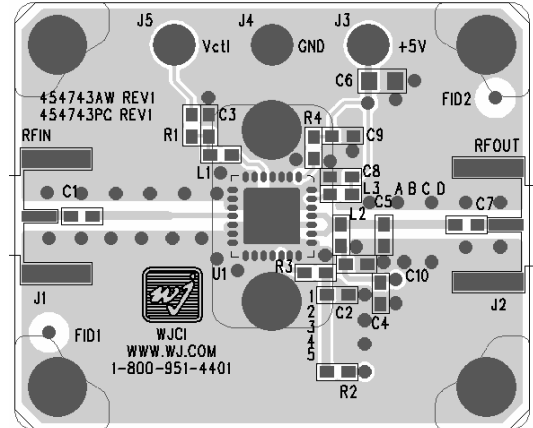
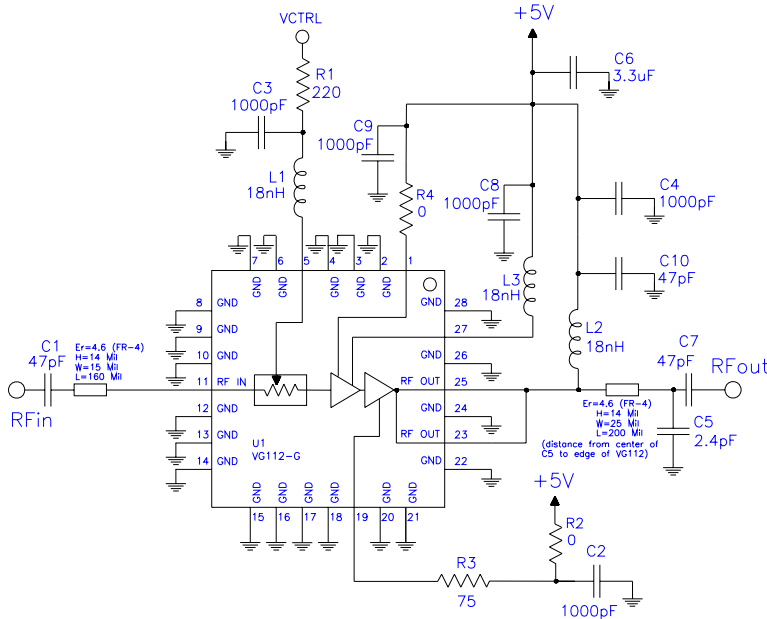

Circuit Board Material: .014" FR-4, 4 layers, .062" total thickness

Bill of Materials

Ref. Des.	Description	Size
C1, C7, C10	47 pF Chip Capacitor	0603
C2, C3, C4, C8, C9	1000 pF Chip Capacitor	0603
C5	2.4 pF Chip Capacitor	0603
C6	3.3 μF Chip Capacitor	0805
L1, L2	18 nH Chip Inductor	0603
R1	220 Ω Chip Resistor	0603
R3	75 Ω Chip Resistor	0603
R2, R4	0 Ω Chip Resistor	0603
U1	VG112-G VGA	QFN 6x6

- The center of C5 should be placed 5mm (.197") away from the edge of the VG112.
- The input trace is a high impedance line and is needed to get a good input match into the VGA.
- The board is optimized for performance at 2140 MHz. Performance at 1960 MHz can be optimized by replacing C5 with 2.7 pF at location A on the WJ VG112 evaluation board.

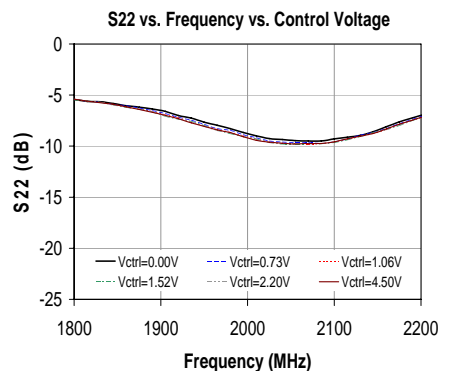
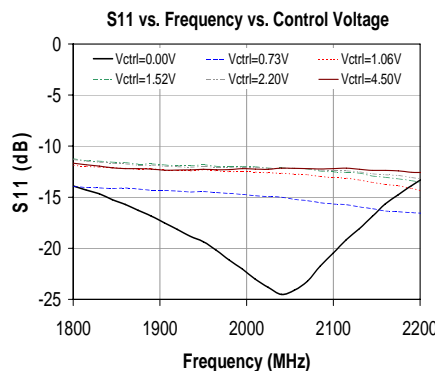
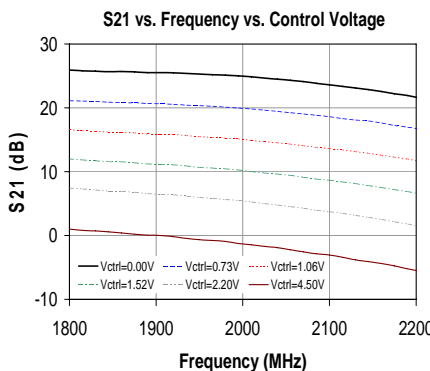
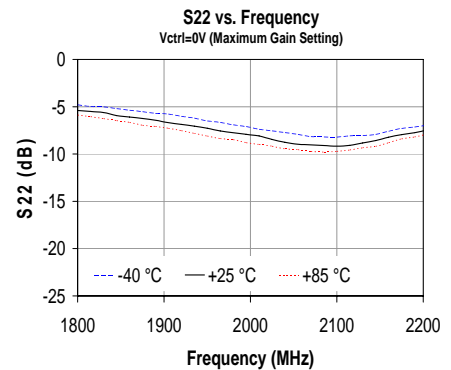
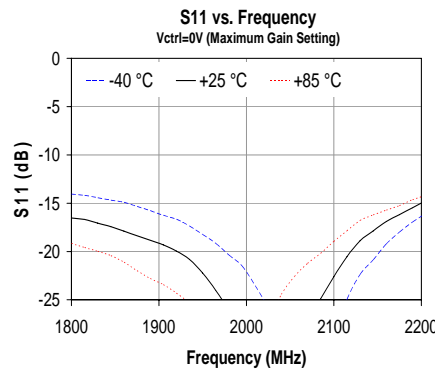
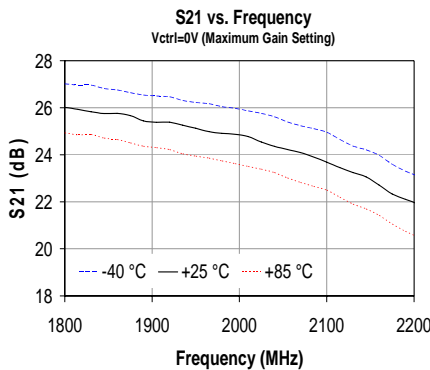

Specifications and information are subject to change without notice



2140 MHz Application Circuit Performance Performance using the circuitry on the VG112-PCB Evaluation Board

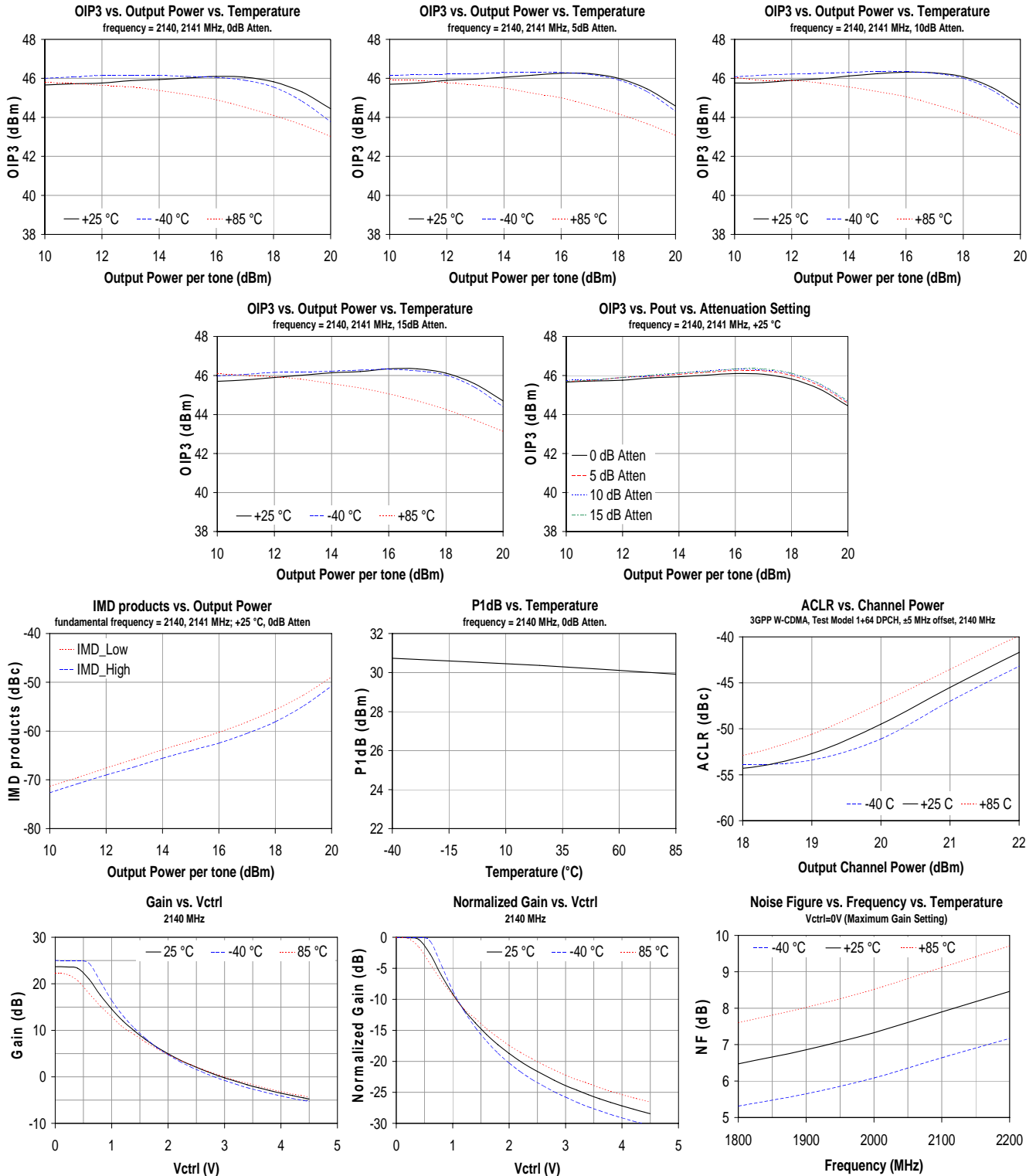

Specifications and information are subject to change without notice

VG112-G Mechanical Information

This package is lead-free/green/RoHS-compliant. The plating material on the pins is annealed matte tin over copper. It is compatible with both lead-free (maximum 260 °C reflow temperature) and leaded (maximum 245 °C reflow temperature) soldering processes.

Outline Drawing

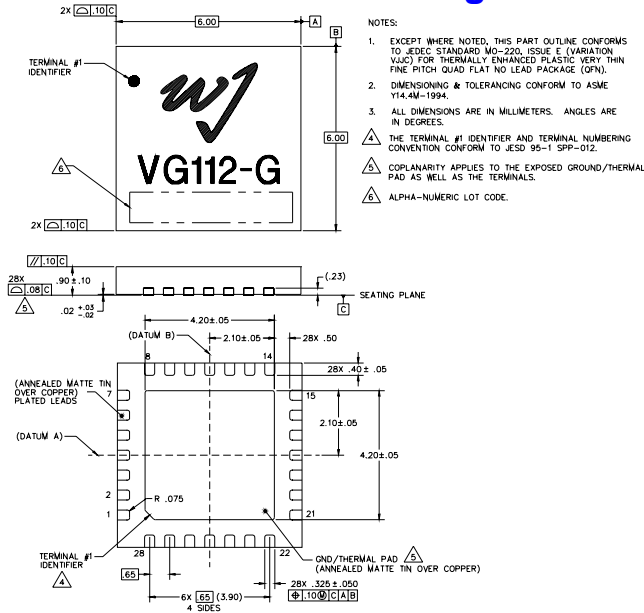

Product Marking

The component will be lasermarked with a “VG112-G” designator with an alphanumeric lot code on the top surface of the package.

Tape and reel specifications for this part will be located on the website in the “Application Notes” section.

ESD / MSL Information



Caution! ESD sensitive device.

ESD Rating: Class 1B
 Value: Passes $\geq 500V$ to $<1000V$
 Test: Human Body Model (HBM)
 Standard: JEDEC Standard JESD22-A114

ESD Rating: Class IV
 Value: Passes $\geq 1000V$ to $<2000V$
 Test: Charged Device Model (CDM)
 Standard: JEDEC Standard JESD22-C101

MSL Rating: Level 2 at +260 °C convection reflow
 Standard: JEDEC Standard J-STD-020

Mounting Configuration / Land Pattern

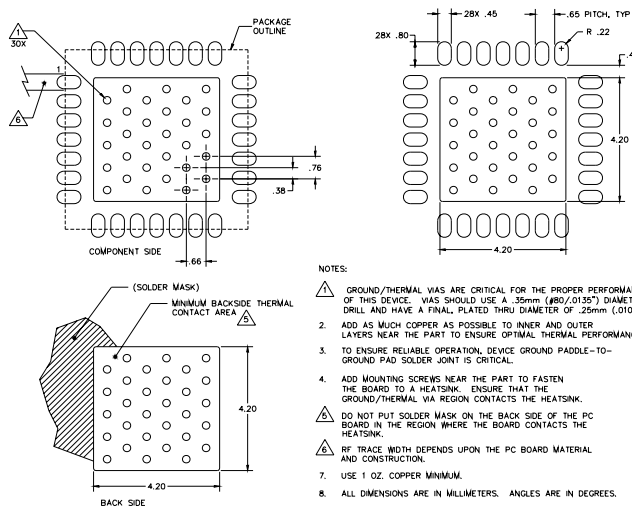

Functional Pin Layout

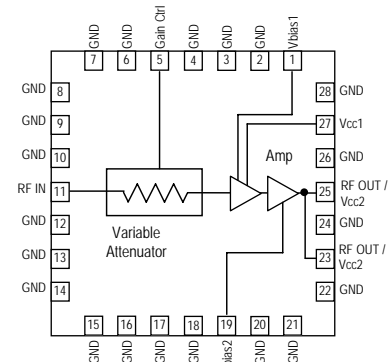

Pin No	Function
1	Vbias1
5	Gain Control
11	RF Input
19	Vbias2
23, 25	RF Output / Vcc2
27	Vcc1
Even numbered pins and backside paddle	Ground
3, 7, 9, 13, 15, 17, 21	No connect or ground

Thermal Specifications

Parameter	Rating
Operating Case Temperature	-40 to +85 °C
Thermal Resistance, Rth ⁽¹⁾	33 °C / W
Junction Temperature, Tj ⁽²⁾	151 °C

Notes:

- The thermal resistance is referenced from the hottest part of the junction to the backside paddle.
- This corresponds to the typical biasing condition of +5V, 400 mA at an 85 °C case temperature. A minimum MTF of 1 million hours is achieved for junction temperatures below 247° C.