

PACKAGE DIMENSIONS inch (mm)

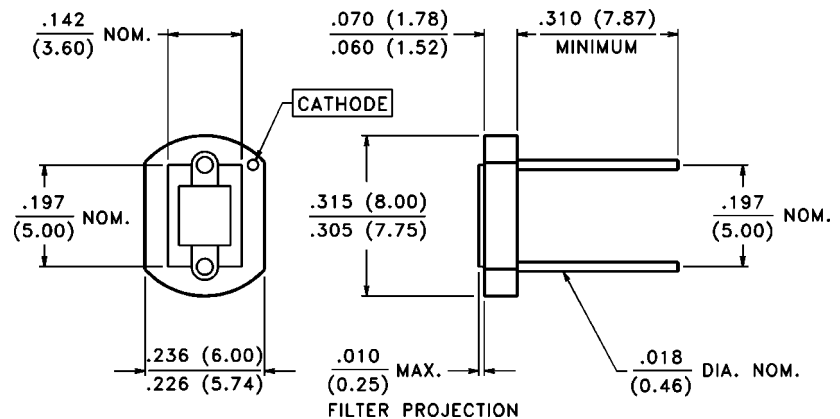

CASE 21F 8 mm CERAMIC
CHIP ACTIVE AREA: .008 in² (5.16 mm²)

PRODUCT DESCRIPTION

Planar silicon photodiode in recessed ceramic package. The package incorporates an infrared rejection filter. These diodes have very high shunt resistance and have good blue response.

ABSOLUTE MAXIMUM RATINGS

Storage Temperature: -20°C to 75°C
Operating Temperature: -20°C to 75°C

ELECTRO-OPTICAL CHARACTERISTICS @ 25°C (See also VTB curves, pages 21-22)

SYMBOL	CHARACTERISTIC	TEST CONDITIONS	VTB8440B			VTB8441B			UNITS
			Min.	Typ.	Max.	Min.	Typ.	Max.	
I _{SC}	Short Circuit Current	H = 100 fc, 2850 K	4	5		4	5		μA
TC I _{SC}	I _{SC} Temperature Coefficient	2850 K		.02	.08		.02	.08	%/°C
V _{OC}	Open Circuit Voltage	H = 100 fc, 2850 K		420			420		mV
TC V _{OC}	V _{OC} Temperature Coefficient	2850 K		-2.0			-2.0		mV/°C
I _D	Dark Current	H = 0, VR = 2.0 V			2000			100	pA
R _{SH}	Shunt Resistance	H = 0, V = 10 mV		.07			1.4		GΩ
TC R _{SH}	R _{SH} Temperature Coefficient	H = 0, V = 10 mV		-8.0			-8.0		%/°C
C _J	Junction Capacitance	H = 0, V = 0		1.0			1.0		nF
λ _{range}	Spectral Application Range		330		720	330		720	nm
λ _p	Spectral Response - Peak			580			580		nm
V _{BR}	Breakdown Voltage		2	40		2	40		V
θ _{1/2}	Angular Resp. - 50% Resp. Pt.			±50			±50		Degrees
NEP	Noise Equivalent Power		1.1 x 10 ⁻¹³ (Typ.)			2.4 x 10 ⁻¹⁴ (Typ.)			W/√Hz
D*	Specific Detectivity		2.2 x 10 ¹² (Typ.)			9.7 x 10 ¹² (Typ.)			cm√Hz / W