

24-bit, 192kHz AV Receiver on-a-Chip

DESCRIPTION

The WM8777 is a high performance, multi-channel audio codec. The WM8777 is ideal for surround sound processing applications for home hi-fi, automotive and other audio visual equipment. A S/PDIF transceiver with 4-channel input mux is included. Analogue domain bass management processing, and front channel analogue tone control facilities are provided.

A stereo 24-bit multi-bit sigma delta ADC is used with a six stereo channel input selector. Each channel has analogue domain mute and programmable gain control. Sampling rates from 8kHz to 192kHz are supported.

Four stereo 24-bit multi-bit sigma delta DACs are provided, which may be used to support up to 7.1 channel operation. If preferred, 5.1 operation may be chosen, with the spare stereo DAC used to support an Aux remote room. Sampling rates from 8kHz to 192kHz are supported. Each DAC channel has independent digital volume and mute control. A set of input multiplexers allows switching of an external 5.1 analogue input, or bypass channel stereo analogue input into the signal path. The front channel analogue signals may be looped out of the chip prior to each master volume control, and external filtering applied in order to select treble and bass filter characteristics. Adjustment of tone controls is then achieved using on-chip gain adjust amplifiers, addressed via the control interface. Analogue bass management support is provided, plus analogue stereo mix down options.

The device is controlled via a serial interface giving access to all features including channel selection, volume controls, tone controls, mutes, de-emphasis and power management facilities. The device is available in a 100-pin LQFP package.

FEATURES

- AV receiver on-a-chip with 8 DACs and 2 ADCs
- Integrated S/PDIF/IEC60958/AES3 transceiver
- Analogue Bass Management and stereo mixdown support
- Analogue tone controls for front 3 channels
- Master volume control on each DAC channel with gain range of +20dB to -100dB in 1dB steps
- Audio Performance
 - 108dB SNR ('A' weighted @ 48kHz) DAC
 - 102dB SNR ('A' weighted @ 48kHz) ADC
 - 110dB SNR ('A' weighted) Analogue volume control
- DAC Sampling Frequency: 8KHz – 192kHz
- ADC Sampling Frequency: 8KHz – 192kHz
- 3-Wire SPI or 2-wire MPU Serial Control Interface with read back.
- Master or Slave Clocking Mode
- Programmable Format Audio Data Interface Modes
- Four Independent stereo DAC outputs with independent digital volume controls
- Integrated Stereo headphone amplifier with source select
- 5.1 channel analogue input prior to the tone controls, bass management and stereo mix down functions.
- Six stereo input ADC mux with analogue gain adjust from +24dB to -21dB in 0.5dB steps
- 5V Analogue, 2.7V to 3.6V Digital supply Operation

APPLICATIONS

- Surround Sound AV Processors and Hi-Fi systems

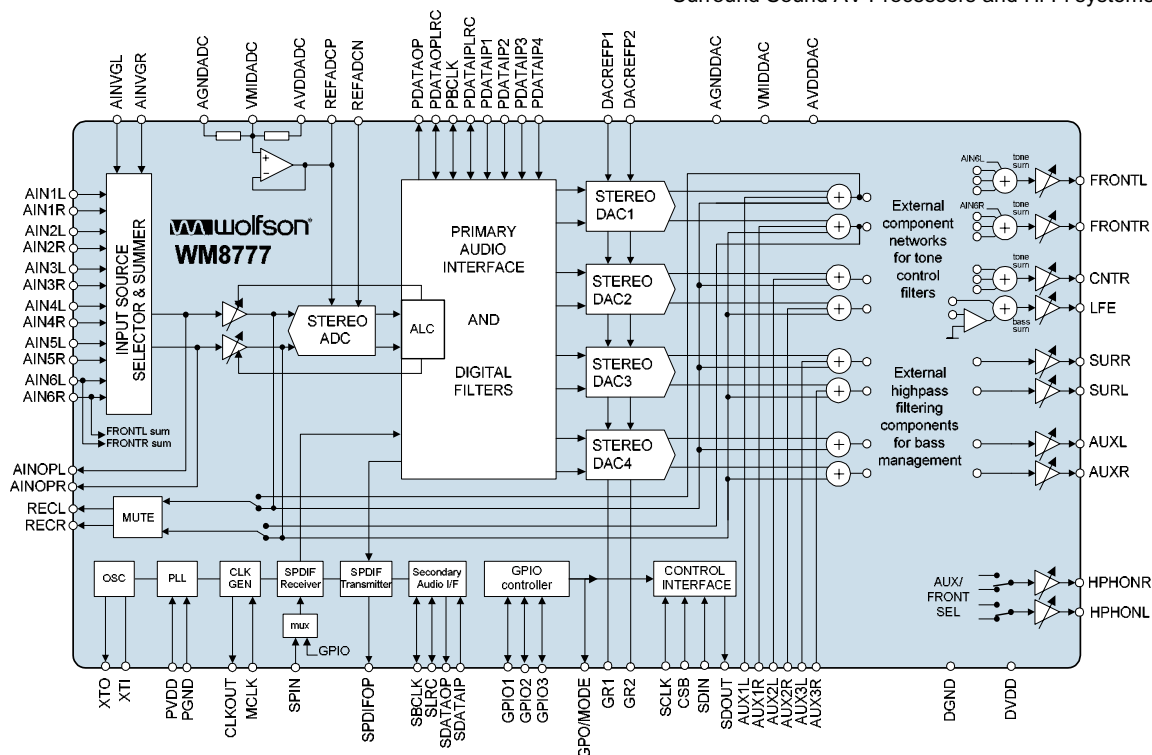
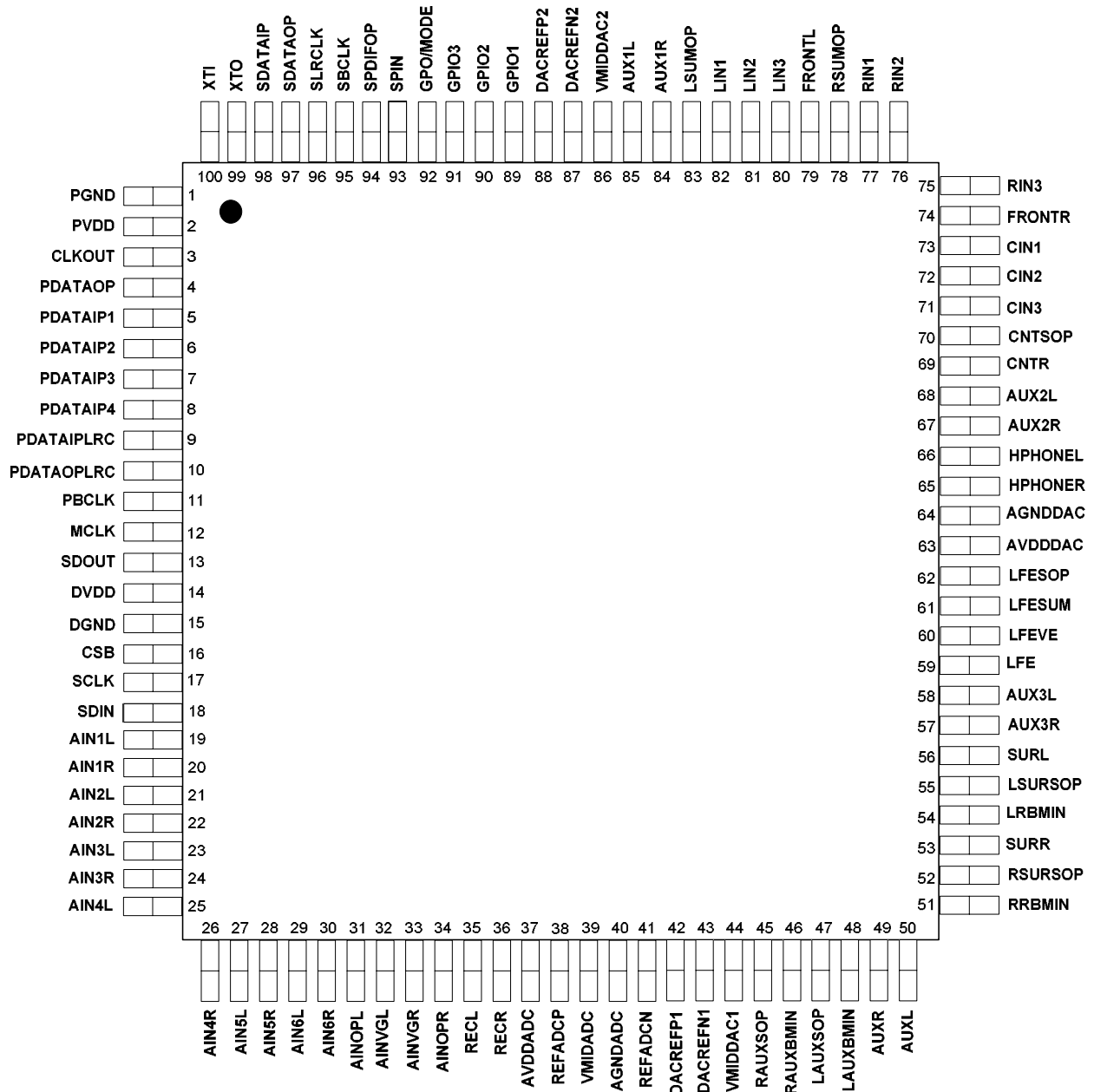

TABLE OF CONTENTS

DESCRIPTION	1
FEATURES.....	1
APPLICATIONS	1
TABLE OF CONTENTS	2
PIN CONFIGURATION.....	3
ORDERING INFORMATION	3
PIN DESCRIPTION	4
ABSOLUTE MAXIMUM RATINGS	6
RECOMMENDED OPERATING CONDITIONS	6
ELECTRICAL CHARACTERISTICS	7
TERMINOLOGY	10
SUPPLY CURRENT	11
DEVICE DESCRIPTION.....	12
INTRODUCTION	12
ANALOGUE TONE CONTROLS	13
BASS MANAGEMENT.....	19
HEADPHONE OUTPUT	20
OUTPUT POWERDOWN.....	21
DIGITAL AUDIO INTERFACE ROUTING OPTIONS.....	22
CONTROL INTERFACE OPERATION.....	24
CONTROL INTERFACE TIMING	27
MASTER CLOCK	29
AUDIO SAMPLING RATES AND AUDIO INTERFACES	30
AUDIO INTERFACE FORMATS.....	35
DIGITAL AUDIO INTERFACE CONTROL REGISTERS	38
POWERDOWN MODES	39
MASTER CLOCK AND PHASE LOCKED LOOP.....	42
S/PDIF TRANSCEIVER FEATURES.....	45
S/PDIF TRANSMITTER.....	47
S/PDIF RECEIVER.....	50
DAC CONTROL REGISTERS.....	56
OUTPUT SELECT AND ENABLE CONTROL	65
ADC CONTROL REGISTERS.....	66
LIMITER / AUTOMATIC LEVEL CONTROL (ALC).....	68
SOFTWARE REGISTER RESET	72
REGISTER MAP.....	73
DIGITAL FILTER CHARACTERISTICS	95
DAC FILTER RESPONSES	96
ADC HIGH PASS FILTER.....	97
DIGITAL DE-EMPHASIS CHARACTERISTICS.....	98
APPLICATIONS INFORMATION	99
EXTERNAL ANALOGUE INPUT CIRCUIT CONFIGURATION	99
EXTERNAL S/PDIF INPUT CIRCUIT CONFIGURATION	100
RECOMMENDED ANALOGUE OUTPUT EXTERNAL COMPONENTS.....	101
IMPORTANT NOTICE	103
ADDRESS:.....	103

PIN CONFIGURATION



ORDERING INFORMATION

DEVICE	TEMPERATURE RANGE	PACKAGE	MOISTURE SENSITIVITY LEVEL	PEAK SOLDERING TEMPERATURE
WM8777SEFT/V	-25°C to +85°C	100-pin TQFP	MSL3	240°C

PIN DESCRIPTION

PIN	NAME	TYPE	DESCRIPTION
1	PGND	Supply	PLL ground supply
2	PVDD	Supply	PLL positive supply
3	CLKOUT	Digital output	PLL output or crystal oscillator output
4	PDATAOP	Digital output	Primary Audio Interface data output (ADC)
5	PDATAIP1	Digital Input	Primary Audio Interface data input 1 (DAC1)
6	PDATAIP2	Digital Input	Primary Audio Interface data input 2 (DAC2)
7	PDATAIP3	Digital Input	Primary Audio Interface data input 3 (DAC3)
8	PDATAIP4	Digital Input	Primary Audio Interface data input 4 (DAC4)
9	PDATAIPLRC	Digital input/output	DAC left/right word clock
10	PDATAOPLRC	Digital input/output	ADC left/right word clock
11	PBCLK	Digital input/output	ADC and DAC audio interface bit clock
12	MCLK	Digital input/output	Master DAC and ADC clock; 128, 192, 256, 384, 512, 768fs or 1152fs (fs = word clock freq)
13	SDOUT	Digital output	Serial interface output data
14	DVDD	Supply	Digital positive supply
15	DGND	Supply	Digital negative supply
16	CSB	Digital input	Serial interface Latch signal (5V tolerant)
17	SCLK	Digital input	Serial interface clock (5V tolerant)
18	SDIN	Digital input	Serial interface data (5V tolerant)
19	AIN1L	Analogue Input	Channel 1 left input multiplexor virtual ground
20	AIN1R	Analogue Input	Channel 1 right input multiplexor virtual ground
21	AIN2L	Analogue Input	Channel 2 left input multiplexor virtual ground
22	AIN2R	Analogue Input	Channel 2 right input multiplexor virtual ground
23	AIN3L	Analogue Input	Channel 3 left input multiplexor virtual ground
24	AIN3R	Analogue Input	Channel 3 right input multiplexor virtual ground
25	AIN4L	Analogue Input	Channel 4 left input multiplexor virtual ground
26	AIN4R	Analogue Input	Channel 4 right input multiplexor virtual ground
27	AIN5L	Analogue Input	Channel 5 left input multiplexor virtual ground
28	AIN5R	Analogue Input	Channel 5 right input multiplexor virtual ground
29	AIN6L	Analogue Input	Channel 6 left input multiplexor virtual ground
30	AIN6R	Analogue Input	Channel 6 right input multiplexor virtual ground
31	AINOPL	Analogue Output	Left channel multiplexor output
32	AINVGL	Analogue Input	Left channel multiplexor virtual ground
33	AINVGR	Analogue Input	Right channel multiplexor virtual ground
34	AINOPR	Analogue Output	Right channel multiplexor output
35	RECL	Analogue Output	Left channel input mux select output
36	RECR	Analogue Output	Right channel input mux select output
37	AVDDADC	Supply	Analogue positive supply for ADC
38	REFADCP	Analogue Output	ADC reference buffer decoupling pin; 10uF external decoupling
39	VMIDADC	Analogue Output	ADC midrail divider decoupling pin; 10uF external decoupling
40	AGNDADC	Supply	Analogue negative supply and substrate connection for ADC
41	REFADCN	Supply	ADC ground reference
42	DACREFP1	Supply	DAC positive reference supply
43	DACREFN1	Supply	DAC ground reference
44	VMIDDAC1	Analogue output	DAC midrail decoupling pin ; 10uF external decoupling
45	RAUXSOP	Analogue output	Right aux/rear channel summer output
46	RAUXBMIN	Analogue input	Right Aux/rear channel bass managed filtered input
47	LAUXSOP	Analogue output	Left aux/rear channel summer output
48	LAUXBMIN	Analogue input	Left Aux/rear channel bass managed filtered input
49	AUXR	Analogue output	DAC aux or rear channel right output
50	AUXL	Analogue output	DAC aux or rear channel left output

PIN	NAME	TYPE	DESCRIPTION
51	RRBMIN	Analogue input	Right surround channel bass managed filtered input
52	RSURSOP	Analogue output	Right surround channel summer output
53	SURR	Analogue output	DAC surround channel right output
54	LRBMIN	Analogue input	Left surround channel bass managed filtered input
55	LSURSOP	Analogue output	Left surround channel summer output
56	SURL	Analogue output	DAC surround channel left output
57	AUX3R	Analogue input	3.1 Multiplexor channel 3 right virtual ground input
58	AUX3L	Analogue input	3.1 Multiplexor channel 3 left virtual ground input
59	LFE	Analogue output	DAC LFE channel right output
60	LFEVE	Analogue Input	LFE channel summer virtual earth
61	LFESUM	Analogue output	LFE channel summer output
62	LFESOP	Analogue output	LFE channel summer output
63	AVDDDAC	Supply	Analogue positive supply for DAC
64	AGNDDAC	Supply	Analogue negative supply and substrate connection for DAC
65	HPHONER	Analogue output	Headphone channel right output
66	HPHONEL	Analogue output	headphone channel left output
67	AUX2R	Analogue input	3.1 Multiplexor channel 2 right virtual ground input
68	AUX2L	Analogue input	3.1 Multiplexor channel 2 left virtual ground input
69	CNTR	Analogue output	DAC centre channel right output
70	CNTSOP	Analogue output	Centre front channel summer output
71	CIN3	Analogue input	Centre channel bass management filter input
72	CIN2	Analogue input	Centre channel bass filter input
73	CIN1	Analogue input	Centre channel treble filter input
74	FRONTR	Analogue output	DAC front channel right output
75	RIN3	Analogue input	Right front channel bass management filter input
76	RIN2	Analogue input	Right front channel bass filter input
77	RIN1	Analogue input	Right front channel treble filter input
78	RSUMOP	Analogue output	Right front channel summer output
79	FRONTL	Analogue output	DAC front channel left output
80	LIN3	Analogue input	Left front channel bass management filter input
81	LIN2	Analogue input	Left front channel bass filter input
82	LIN1	Analogue input	Left front channel treble filter input
83	LSUMOP	Analogue output	Left front channel summer output
84	AUX1R	Analogue input	3.1 Multiplexor channel 1 right virtual ground input
85	AUX1L	Analogue input	3.1 Multiplexor channel 1 left virtual ground input
86	VMIDDAC2	Analogue output	DAC midrail decoupling pin ; 10uF external decoupling
87	DACREFN2	Supply	DAC ground reference
88	DACREFP2	Supply	DAC positive reference supply
89	GPIO1	Digital input/output	Selectable i/o (S/PDIF input, status flag output or ADCMCLK)
90	GPIO2	Digital input/output	Selectable i/o (S/PDIF input, status flag output, or PDATAOPBCLK)
91	GPIO3	Digital input/output	Selectable i/o (S/PDIF input or status flag output)
92	GPO/MODE	Digital input/output	Selectable i/o (state at RESET determines control interface type)
93	SPIN	Digital input	S/PDIF input
94	SPDIFOP	Digital output	S/PDIF output
95	SBCLK	Digital input/output	Secondary Audio Interface bit clock
96	SLRC	Digital input/output	Secondary Audio Interface left/right clock
97	SDATAOP	Digital output	Secondary Audio Interface output data
98	SDATAIP	Digital Input	Secondary Audio Interface input data
99	XTO	Crystal op	Crystal oscillator output
100	XTI	Digital input	Crystal oscillator or external clock inputs

ABSOLUTE MAXIMUM RATINGS

Absolute Maximum Ratings are stress ratings only. Permanent damage to the device may be caused by continuously operating at or beyond these limits. Device functional operating limits and guaranteed performance specifications are given under Electrical Characteristics at the test conditions specified.



ESD Sensitive Device. This device is manufactured on a CMOS process. It is therefore generically susceptible to damage from excessive static voltages. Proper ESD precautions must be taken during handling and storage of this device.

As per specification IPC/JEDEC J-STD-020B, this product requires specific storage conditions prior to surface mount assembly. It has a Moisture Sensitivity Level of 3 and as such will be supplied in vacuum-sealed moisture barrier bags, with an out of bag exposure time limit of 1 week at less than 30°C / 60% RH.

CONDITION	MIN	MAX
Digital supply voltage	-0.3V	+3.63V
Analogue supply voltage	-0.3V	+7V
Voltage range digital inputs (SDIN, SCLK, CSB)	DGND -0.3V	+7V
Voltage range digital inputs (MCLK, DIN[3:0], PDATAOPLRC, PDATAIPLRC and PBCLK)	DGND -0.3V	DVDD + 0.3V
Voltage range analogue inputs	AGND -0.3V	AVDD +0.3V
Master Clock Frequency		37MHz
Operating temperature range, T _A	-25°C	+85°C
Storage temperature	-65°C	+150°C

Note:

- Analogue and digital grounds must always be within 0.3V of each other.

RECOMMENDED OPERATING CONDITIONS

PARAMETER	SYMBOL	TEST CONDITIONS	MIN	TYP	MAX	UNIT
Digital supply range	DVDD		2.7		3.6	V
Analogue supply range	AVDDDAC,AVDDACD, PVDD		4.5		5.5	V
Analogue Reference range	VREFP		4.5		5.5	
Ground	AGNDDAC, AGNDADC, PGND, DGND, VREFN			0		V
Difference DGND to AGNDDAC/AGNDADC/PLL GND			-0.3	0	+0.3	V

ELECTRICAL CHARACTERISTICS

Test Conditions

AVDDDAC = 5V, AVDDADC=5V, DVDD = 3.3V, AGNDAC = 0V, AGNDADC = 0, DGND = 0V, T_A = +25°C, fs = 48kHz, MCLK = 256fs, ADC/DAC in Slave Mode unless otherwise stated.

PARAMETER	SYMBOL	TEST CONDITIONS	MIN	TYP	MAX	UNIT
Digital Logic Levels (CMOS Levels)						
Input LOW level	V _{IL}				0.3 X DVDD	V
Input HIGH level	V _{IH}		0.7 X DVDD			V
Input Leakage Current				±0.2		µA
Input Capacitance				5		pF
Output LOW	V _{OL}	I _{OL} =1mA			0.1 x DVDD	V
Output HIGH	V _{OH}	I _{OH} =1mA	0.9 x DVDD			V
Analogue Reference Levels						
Reference voltage	V _{VMID} (DAC)			VREFP/2		V
	V _{VMID} (ADC)			AVDDADC/2		V
Potential divider resistance	R _{VMID} (DAC)	VREFP to VMID and VMID to VREFN		50k		Ω
	R _{VMID} (ADC)	AVDDADC to VMID and VMID to AGNDADC		50k		Ω
DAC Performance (Load = 10k Ω, 50pF) to pins L/RSUMOP, CNTSOP, LFESOP, L/RSUROP, L/RAUXSOP						
0dBfs Full scale output voltage				1.0 x VREFP/5		V _{rms}
SNR (Note 1,2)		A-weighted, @ fs = 48kHz	100	108		dB
SNR (Note 1,2)		A-weighted @ fs = 96kHz		108		dB
Dynamic Range (Note 2)	DNR	A-weighted, -60dB full scale input	100	108		dB
Total Harmonic Distortion (THD)		1kHz, 0dBfs		-96	-90	dB
DAC channel separation				110		dB
DAC Mute attenuation		1kHz Input, 0dB gain		88		dB
Power Supply Rejection Ratio	PSRR	1kHz 100mVpp		50		dB
		20Hz to 20kHz 100mVpp		45		dB
DAC Digital Volume						
DAC Digital volume control range			-127.5		0	dB
DAC Digital volume step size				0.5		dB
ADC Performance						
Input Signal Level (0dB)				1.0 x AVDDADC/5		V _{rms}
SNR (Note 1,2)		A-weighted, 0dB gain @ fs = 48kHz	96	102		dB
SNR (Note 1,2)		A-weighted, 0dB gain @ fs = 96kHz		100		dB
Dynamic Range (note 2)		A-weighted, -60dB full scale input	96	102		dB
Total Harmonic Distortion (THD)		1kHz, 0dBfs		-89		dB
		1kHz, -1dBfs		-94	-87	dB
ADC Channel Separation		1kHz Input		85		dB
Programmable Gain Step Size				0.5		dB
Programmable Gain Range (Analogue)		1kHz Input	-21		+24	dB
Programmable Gain Range (Digital)		1kHz Input	-103		-21.5	dB
Mute Attenuation		1kHz Input, 0dB gain		82		dB

Test Conditions

AVDDDAC = 5V, AVDDADC=5V, DVDD = 3.3V, AGNDAC = 0V, AGNDADC = 0, DGND = 0V, T_A = +25°C, fs = 48kHz, MCLK = 256fs, ADC/DAC in Slave Mode unless otherwise stated.

PARAMETER	SYMBOL	TEST CONDITIONS	MIN	TYP	MAX	UNIT
Power Supply Rejection Ratio	PSRR	1kHz 100mVpp		50		dB
		20Hz to 20kHz 100mVpp		45		dB
Input Resistance (AIN1 -> AIN6)				20		kΩ
Input Capacitance (AIN1 -> AIN6)				10		pF
ADC PGA Output to Analogue Output (L/RSUMOP, CNTSOP, LFESOP, L/RSUOP, L/RAUXSOP) (Load=10k Ω, 50pF, gain = 0dB) Bypass Mode						
0dB Full scale output voltage				1.0 x AVDDDAC/5		Vrms
SNR (Note 1)			100	105		dB
THD		1kHz, 0dB		-93		dB
		1kHz, -3dB		-95		dB
Power Supply Rejection Ratio	PSRR	1kHz 100mVpp		50		dB
		20Hz to 20kHz 100mV		45		dB
Mute Attenuation		1kHz, 0dB		88		dB
Analogue Input (AIN6) to Analogue Output (FRONTL, FRONTR) (Load=10k Ω, 50pF, gain = 0dB) Bypass Mode						
0dB Full scale output voltage				1.0 x AVDDDAC/5		Vrms
SNR (Note 1)			100	105		dB
THD		1kHz, 0dB		-93		dB
		1kHz, -3dB		-95		dB
Power Supply Rejection Ratio	PSRR	1kHz 100mVpp		50		dB
		20Hz to 20kHz 100mV		45		dB
Mute Attenuation		1kHz, 0dB		88		dB
ADC PGA to REC Output						
0dB Full scale output voltage				1.0 x AVDDDAC/5		Vrms
SNR (Note 1)			100	104		dB
THD		1kHz, 0dB		-87		dB
		1kHz, -3dB		-89		dB
Power Supply Rejection Ratio	PSRR	1kHz 100mVpp		50		dB
		20Hz to 20kHz 100mV		45		dB
Mute Attenuation		1kHz, 0dB		88		dB
L/RSUMOP to REC Output						
0dB Full scale output voltage				1.0 x AVDDDAC/5		Vrms
SNR (Note 1)			97	100		dB
THD		1kHz, 0dB		-94		dB
		1kHz, -3dB		-96		dB
Power Supply Rejection Ratio	PSRR	1kHz 100mVpp		50		dB
		20Hz to 20kHz 100mV		45		dB
Mute Attenuation		1kHz, 0dB		88		dB
L/RAUX Input to Analogue Output (L/RSUMOP, CNTSOP, LFESOP, L/RSUOP, L/RAUXSOP) (Load=10k Ω, 50pF, gain = 0dB)						
0dB Full scale output voltage				1.0 x AVDDDAC/5		Vrms
SNR (Note 1)			103	107		dB
THD		1kHz, 0dB		-94		dB
		1kHz, -3dB		-96		dB
Power Supply Rejection Ratio	PSRR	1kHz 100mVpp		50		dB
		20Hz to 20kHz 100mV		45		dB
Mute Attenuation		1kHz, 0dB		88		dB

Test Conditions

AVDDDAC = 5V, AVDDADC=5V, DVDD = 3.3V, AGNDAC = 0V, AGNDADC = 0, DGND = 0V, T_A = +25°C, fs = 48kHz, MCLK = 256fs, ADC/DAC in Slave Mode unless otherwise stated.

PARAMETER	SYMBOL	TEST CONDITIONS	MIN	TYP	MAX	UNIT
Volume Controls (FRONTL, FRONTR, CNTR, LFE, SURR, SURL, AUXL, AUXR, HPHONER, HPHONEL)						
Analogue output Volume Gain Step Size			0.5	1	1.5	dB
Analogue output Volume Gain Range		1kHz Input	-88		+20	dB
Analogue output Volume Mute Attenuation		1kHz Input, 0dB gain		88		dB
Analogue Tone volume step size				1		dB
Analogue Bass Management and Tone Controls						
Treble range adjustment			-10		+10	dB
Treble step size				1		dB
Bass range adjustment			-10		+10	dB
Bass step size				1		dB
Headphone Amplifier at 0dB Volume (Load=16 Ω, at 1Vrms)						
Headphone output level				1.0		Vrms
THD				-70		dB
SNR				-102		dB
Headphone Amplifier at 0dB Volume (Load=32 Ω, at 1Vrms)						
Headphone output level				1.0		Vrms
THD				-78		dB
SNR				-102		dB
S/PDIF Transceiver						
Jitter on recovered clock (Rms period jitter)				50		Ps
S/PDIF Input Levels CMOS MODE						
Input LOW level	V _{IL}				0.3 X DVDD	V
Input HIGH level	V _{IH}		0.7 X DVDD			V
Input capacitance				1.25		pF
Input Frequency					36	MHz
S/PDIF Input Levels Comparator MODE						
Input capacitance				1.31		pF
Input resistance				18		Ω
Input frequency					25	MHz
Input Amplitude			200		0.5 X DVDD	mV
PLL						
Period Jitter				80		ps(rms)
XTAL						
Input XTI LOW level	VX _{IL}		0		557	mV
Input XTI HIGH level	VX _{IH}		853			mV
Input XTI capacitance	C _{XJ}		3.32		4.491	pF
Input XTI leakage	IX _{leak}		28.92		38.96	mA
Output XTO LOW	VX _{OL}	15pF load capacitors	86		278	mV
Output XTO HIGH	VX _{OH}	15pF load capacitors	1.458		1.942	V

Notes:

- Ratio of output level with 1kHz full scale input, to the output level with all zeros into the digital input, measured 'A' weighted.
- All performance measurements done with 20kHz low pass filter, and where noted an A-weight filter. Failure to use such a filter will result in higher THD+N and lower SNR and Dynamic Range readings than are found in the Electrical Characteristics. The low pass filter removes out of band noise; although it is not audible it may affect dynamic specification values.
- VMID decoupled with 10uF and 0.1uF capacitors (smaller values may result in reduced performance).

TERMINOLOGY

1. Signal-to-noise ratio (dB) - SNR is a measure of the difference in level between the full scale output and the output with no signal applied. (No Auto-zero or Automute function is employed in achieving these results).
2. Dynamic range (dB) - DNR is a measure of the difference between the highest and lowest portions of a signal. Normally a THD+N measurement at 60dB below full scale. The measured signal is then corrected by adding the 60dB to it. (e.g. THD+N @ -60dB= -32dB, DR= 92dB).
3. THD+N (dB) - THD+N is a ratio, of the rms values, of (Noise + Distortion)/Signal.
4. Stop band attenuation (dB) - Is the degree to which the frequency spectrum is attenuated (outside audio band).
5. Channel Separation (dB) - Also known as Cross-Talk. This is a measure of the amount one channel is isolated from the other. Normally measured by sending a full scale signal down one channel and measuring the other.
6. Pass-Band Ripple - Any variation of the frequency response in the pass-band region.

SUPPLY CURRENT

The supply current of the WM8777 depends on the operating mode. For example, the supply current is lower when the device is used for playback-only (ADC off) or recording-only (DACs off). The supply currents for various operating modes are shown in Table 1 below.

MODE DESCRIPTION	SUPPLY CURRENT					
	AVDDDAC	AVDDADC	PVDD	DVDD	TOTAL	UNIT
On power-up, no clks applied	2.81	1.89	0.30	0.39	5.39	mA
On power-up, clks applied	2.81	1.89	0.30	1.70	6.70	mA
ADC	2.71	38.86	0.30	5.80	47.67	mA
All DACs	55.35	1.90	0.30	18.61	76.16	mA
ADC, All DACs	53.45	38.69	0.30	22.4	114.84	mA
ADC, All DACs, Osc	53.44	38.70	1.12	22.4	115.66	mA
ADC, All DACs, Osc, PLL	53.38	38.62	3.74	28.65	124.39	mA
ADC, All DACs, Osc, PLL, S/PDIF	53.38	38.62	3.43	29.89	125.32	mA
ADC, All DACs, Osc, PLL, S/PDIF, Tone	87.53	38.53	3.43	29.99	159.48	mA
ADC, All DACs, Osc, PLL, S/PDIF, Tone, HP (16 Ohm)	146.60	38.42	3.44	29.99	218.45	mA
Power-down, no clks applied	0.028	0.172	0.30	0.39	0.89	mA
Power-down, clks applied	0.028	0.172	0.30	1.60	2.10	mA
Software RESET	2.80	1.88	0.3	0.95	5.93	mA

Table 1 Supply Current for Functional Blocks

Notes:

1. DAC Analogue supply (AVDDDAC) = 5V.
2. ADC Analogue supply (AVDDADC) = 5V.
3. PLL Analogue supply (PVDD) = 5V.
4. Digital supply (DVDD) = 3.3V.

DEVICE DESCRIPTION

INTRODUCTION

WM8777 is a complete 8-channel DAC, 2-channel ADC audio codec, with integrated S/PDIF transceiver, analogue tone controls and bass management including analogue volume controls on each channel.

The device is implemented as four separate stereo DACs and a stereo ADC with flexible input multiplexer, in a single package and controlled by a single interface.

The four stereo channels may either be used to implement a 5.1 channel surround system, with additional stereo channel for a stereo mix down channel, or for a complete 7.1 channel surround system.

An analogue bypass path option is available, to allow stereo analogue signals from any of the 8 stereo inputs to be sent to the stereo outputs via the main volume controls. This allows a purely analogue input to analogue output high quality signal path to be implemented if required. This would allow, for example, the user to play back a 5.1 channel surround movie through 6 of the DACs, whilst playing back a separate analogue or digital signal into a remote room installation.

The WM8777 has two digital audio interfaces. The primary audio interface has separate inputs for each stereo DAC, and one data output which can output digital data from the ADC, received S/PDIF data or data received from the secondary audio interface. Data directed to DAC1 is also directed to the S/PDIF transmitter. The secondary audio interface has a single data input and a single data output. The input data can be output over the primary audio interface, or converted into S/PDIF format and output over the S/PDIF transmitter. Both audio interfaces may be configured to operate in either master or slave mode and support right justified, left justified and I²S interface formats along with a highly flexible DSP serial port interface.

The input multiplexer to the ADC is configured to allow large signal levels to be input to the ADC, using external resistors to reduce the amplitude of larger signals to within the normal operating range of the ADC. The ADC input PGA also allows input signals to be gained up to +24dB and attenuated down to -21dB. This allows the user maximum flexibility in the use of the ADC.

A selectable stereo record output is also provided on RECL/R. It is intended that the RECL/R outputs are only used to drive a high impedance buffer.

Each DAC has its own digital volume control. The digital volume control changes can be made in 0.5dB steps. In addition a zero cross detect circuit is provided for each DAC. The digital volume control detects a transition through the zero point before updating the volume. This minimises audible clicks and 'zipper' noise as the gain values change. In addition to this there is an analogue volume control on each of the tone outputs, with a zero cross detect circuit. The analogue volume control changes can be made in 1dB steps. When analogue volume zero-cross detection is enabled the attenuation values are only updated when the input signal to the gain stage is close to the analogue ground level.

Additionally, 6 of the DAC outputs incorporate an input selector and mixer allowing an external 6 channel, or 5.1 channel signal, to be either switched into the signal path in place of the DAC signal or mixed with the DAC signal.

Control of internal functionality of the device is by 3-wire SPI or 2-wire serial control interface selectable by the state of the GPO/MODE pin on power up. The control interface may be asynchronous to the audio data interface as control data will be re-synchronised to the audio processing internally.

CSB, SCLK, and SDIN are 5V tolerant with TTL input thresholds, allowing the WM8777 to be used with DVDD = 3.3V and be controlled by a controller with 5V output.

Operation using a system clock of 128fs, 192fs, 256fs, 384fs, 512fs, 768fs or 1152fs is provided. In Slave mode selection between clock rates is automatically controlled. In master mode the master clock to sample rate ratio is set by control bits PAIFTX_RATE and PAIFRX_RATE. The ADC and DAC may run at different rates within the constraint of a common master clock. For example with master clock at 24.576MHz, a DAC sample rate of 96kHz (256fs mode) and an ADC sample rate of 48kHz (512fs mode) can be accommodated. Sample rates (fs) from less than 8ks/s up to 192ks/s are allowed, provided the appropriate system clock is input.

ANALOGUE TONE CONTROLS

Facilities are provided for implementation of analogue treble and bass tone controls on each of the Front left, right and centre channels. External R and C values are used to set the corner frequencies of these tone control functions, allowing the system builder to choose the required responses.

Adjustment of the amplitude of the required tone response is made electronically by writing the required gain or attenuation value into the WM8777 over the serial control interface. Maximum boost or attenuation of tone control values of +/-10dB in 1dB steps is provided.

A tone control bypass path is provided, plus input summing paths for Rear (i.e. Surround L/R), Centre and LFE channels, to allow for creation of a stereo 'mix-down' signal when only two speakers are supported. Each of these mix-down paths has independent gain adjust from 0dB to -6dB in 1dB steps.

An analogue input bypass path is also provided. This allows AIN6L and AIN6R to be output on the FRONTL and FRONTR output channels making use of the volume controls if required.

In order to provide sufficient headroom for cases where significant amounts of analogue treble or bass boost have been applied, a gain attenuation control is provided in the summing stage after the tone adjust PGAs. This allows attenuation of -6dB, -12dB or -18dB to be applied. Re-adjustment of the nominal 0dB signal level may then be made in the following volume control stage as required.

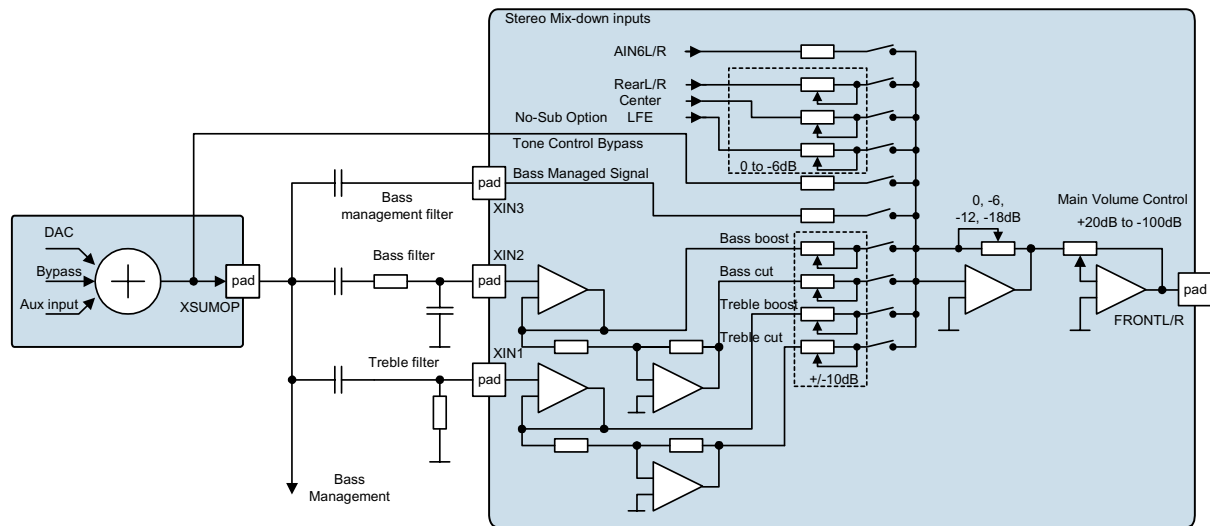

Figure 1 Tone Control Configuration - Front Left/Right (single channel shown)

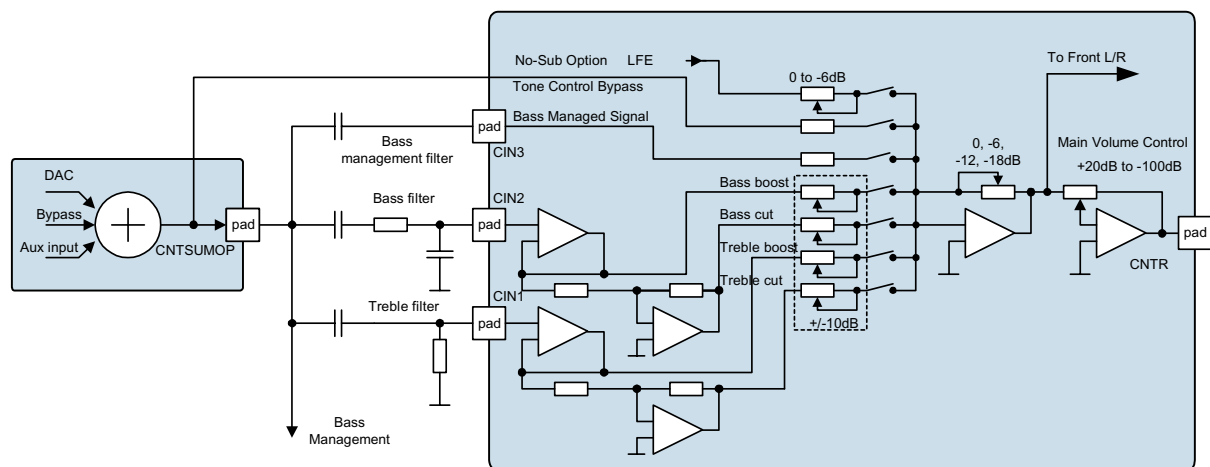

Figure 2 Tone Control Configuration - Centre Channel

MIXER CONTROL

Control of the front channel signal paths is via five software registers. The first three registers control both the front left and right channels whilst the remaining two control the centre channel. When only two speakers are available a stereo mix-down signal can be created by setting the REAR, CNTR and LFE bits of the appropriate register.

Control of the tone characteristics for a channel is determined by writing to the XTRBL and XBASS register bits (where X implies either Front L/R or Centre channel). The tone controls work by adding/subtracting high/low-pass filtered signal content to the nominal 0dB bass-managed signal. Thus when using the tone controls, the XBM bit should also be set. Note also that cut and boost cannot be applied simultaneously. If both bits are set, the tone control signal path will be bypassed but the amplifiers will remain enabled. To avoid pop-noises during dynamic tone control it is recommending that this method is used to disable the tone control signal path. Setting both bits low disables the path, however it will also cause the amplifiers to power down.

The mixer control registers (FTRBL, FBASS, CTRBL and CBASS) share the zero-cross detect circuit used by the analogue volume control. Thus the ZCEN enable bit for a particular channel can be used to determine whether or not the tone control signal path select signals are updated only on a zero-cross condition.

The bypass path is selected by setting the FBYP bit for the front L/R channels and the CBYP bit for the centre channel. The centre, rear and LFE channels can all be independently summed into the front L/R channels by setting the CNTR, REAR and FLFE bits respectively. Each of these signal paths has independent gain control from 0 to -6dB, adjustable in 1dB steps. These gains are determined by writing to the attenuation registers CNTRGAIN, REARGAIN and FLFEGAIN respectively.

The LFE channel can also be summed into the front centre channel by setting the CLFE bit. This path also has independent gain control from 0 to -6dB, controlled by writing to the CLFEGAIN register.

REGISTER ADDRESS	BIT	LABEL	DEFAULT	DESCRIPTION
(22h) FRONT Mixer Control 1	1:0	FTRBL[1:0]	00	Control treble boost and cut:- 00 = both off (Amps disabled) 01 = Treble cut 10 = Treble boosted 11 = both off (Amps enabled)
	3:2	FBASS[1:0]	00	Controls bass boost and cut:- 00 = both off (Amps disabled) 01 = Bass cut 10 = Bass boosted 11 = both off (Amps enabled)
	4	FBM	0	Bass Managed Signal path select 0 = Open 1 = Closed
	5	FBYP	0	Tone Control Bypass signal path select 0 = Open 1 = Closed
	6	AIN6	0	0 = AIN6 not selected 1 = AIN6 applied to FRONT channels
(23h) FRONT Mixer Control 2	2:0	FLFEGAIN[2:0]	000	Front LFE gain: 000 = 0dB 001 = 1dB 010 = 2dB 011 = 3dB 100 = 4dB 101 = 4.5dB 110 = 5dB 111 = 6dB

REGISTER ADDRESS	BIT	LABEL	DEFAULT	DESCRIPTION
	3	FLFE	0	LFE signal path select 0 = Open 1 = Closed
	6:4	CNTRGAIN[2:0]	000	Front CNTR gain: 000 = 0dB 001 = 1dB 010 = 2dB 011 = 3dB 100 = 4dB 101 = 4.5dB 110 = 5dB 111 = 6dB
	7	CNTR	0	Centre signal path mix 0 = Open 1 = Closed
(24h) FRONT Mixer Control 3	2:0	REARGAIN[2:0]	000	Front REAR gain: 000 = 0dB 001 = 1dB 010 = 2dB 011 = 3dB 100 = 4dB 101 = 4.5dB 110 = 5dB 111 = 6dB
	3	REAR	0	Rear signal path mix
(25h) Center Mixer Control 1	1:0	CTRBL[1:0]	00	Control treble boost and cut: 00 = both off 01 = Treble cut 10 = Treble boosted 11 = both off
	3:2	CBASS[1:0]	00	Controls bass boost and cut:- 00 = both off 01 = Bass cut 10 = Bass boosted 11 = both off
	4	CBM	0	Bass Managed Signal path select 0 = Open 1 = Closed
	5	CBYP	0	Tone Control Bypass signal path select 0 = Open 1 = Closed
(26h) Center Mixer Control 2	2:0	CLFEGAIN[2:0]	000	Center LFE gain:- 000 = 0dB 001 = 1dB 010 = 2dB 011 = 3dB 100 = 4dB 101 = 4.5dB 110 = 5dB 111 = 6dB
	3	CLFE	0	LFE signal path select 0 = Open 1 = Closed

Table 2 Output Mixer Control Registers

TONE CONTROL GAIN

The amplitude of the tone response is controlled by writing gain values to the appropriate gain registers. The front left and right channels share gain registers, whilst the centre channel may be controlled independently. Table 3 shows how the attenuation levels for the tone control blocks are selected from the 4-bit code words.

The tone control attenuation registers share the zero-cross detect circuit used by the analogue volume control. Thus the ZCEN enable bit for a particular channel can be used to determine whether or not the treble/bass attenuation registers for that channel are updated only on a zero-cross condition.

CUT/BOOST	CODE[3:0]	ATTENUATION LEVEL
BOOST	0000	+1dB
	0001	+2dB
	.	.
	.	.
	1001	+10dB
CUT	0000	-1dB
	0001	-2dB
	.	.
	.	.
	1001	-10dB

Table 3 Tone Control Attenuation Levels

REGISTER ADDRESS	BIT	LABEL	DEFAULT	DESCRIPTION
(28h) Front Bass Control	3:0	FBASS[3:0]	0000	Gain control for Bass boost/cut
	8	UPDATE	Not latched	Controls simultaneous update of all Attenuation Latches 0 = Store GAIN FRONT BASS in intermediate latch (no change to output) 1 = Store GAIN FRONT BASS and update attenuation on all channels.
(29h) Front Treble Control	3:0	FTREB[3:0]	0000	Gain control for Bass boost/cut
	8	UPDATE	Not latched	Controls simultaneous update of all Attenuation Latches 0 = Store GAIN FRONT TREBLE in intermediate latch (no change to output) 1 = Store GAIN FRONT TREBLE and update attenuation on all channels.
(2Ah) Center Bass Control	3:0	CBASS[3:0]	0000	Gain control for Bass boost/cut
	8	UPDATE	Not latched	Controls simultaneous update of all Attenuation Latches 0 = Store GAIN CENTER BASS in intermediate latch (no change to output) 1 = Store GAIN CENTER BASS and update attenuation on all channels.
(2Bh) Center Treble Control	3:0	CTREB[3:0]	0000	Gain control for Bass boost/cut
	8	UPDATE	Not latched	Controls simultaneous update of all Attenuation Latches 0 = Store GAIN CENTER TREBLE in intermediate latch (no change to output) 1 = Store GAIN CENTER TREBLE and update attenuation on all channels.

Table 4 Tone Control Gain Registers

tone control pre-gain

The tone pre-gain is applied directly before the analogue volume control for a channel. This is to allow scaling of the channel response prior to the overall channel volume control.

Each of the front right, left and centre channels accept their own 2-bit gain code to determine to amount of attenuation applied. The Attenuation levels are given in Table 5.

PRE-GAIN[0:1]	ATTENUATION
00	0dB
01	-6dB
10	-12dB
11	-18dB

Table 5 Tone Control Pre-Gain Attenuation

REGISTER ADDRESS	BIT	LABEL	DEFAULT	DESCRIPTION
(2Ch) Mixer Pregain	1:0	CNTP[1:0]	00	PREGAIN control for CNTR control channel 00 = 0dB Attenuation 01 = -6dB Attenuation 10 = -12dB Attenuation 11 = -18dB Attenuation
	3:2	FTRP[1:0]	00	PREGAIN control for FRONTR tone control channel 00 = 0dB Attenuation 01 = -6dB Attenuation 10 = -12dB Attenuation 11 = -18dB Attenuation
	5:4	FTLP[1:0]	00	PREGAIN control for FRONTL tone control channel 00 = 0dB Attenuation 01 = -6dB Attenuation 10 = -12dB Attenuation 11 = -18dB Attenuation
	6	UPDATEC	0	Controls simultaneous update of all Attenuation Latches 0 = Store PREGAIN CNTR in intermediate latch (no change to output) 1 = Store PREGAIN CNTR and update attenuation on all channels.
	7	UPDATER	0	Controls simultaneous update of all Attenuation Latches 0 = Store PREGAIN RIGHT in intermediate latch (no change to output) 1 = Store PREGAIN RIGHT and update attenuation on all channels.
	8	UPDATEL	0	Controls simultaneous update of all Attenuation Latches 0 = Store PREGAIN LEFT in intermediate latch (no change to output) 1 = Store PREGAIN LEFT and update attenuation on all channels.

Table 6 Mixer Pre-Gain Registers

BASS MANAGEMENT

Support is provided for Bass Management in the analogue domain. This might be used either in the case where a partnering DSP has insufficient MIPS to support all required functions, or where an analogue multi-channel input is required to be processed for use with 'small' bass-limited speakers.

Provision is made for single pole high pass filtering of each front, centre, surround or rear channel, using a single external capacitor. The value of this capacitor may be chosen to set the required high-pass corner frequency, typically the Dolby recommended 100Hz value being preferred. Use of extra external FET switches would allow the system builder to adjust this corner frequency in the system.

To create the subwoofer channel signal, each of up to all 6 channels is summed into the LFE channel using external discrete summing resistors, and the entire summed subwoofer signal then low-pass band-limited using a further user selectable external capacitor value. This allows the gain from each individual channel, and the overall bass corner response to be selected. Following this summing stage, an integrated volume control allows the overall level of the subwoofer channel to be set.

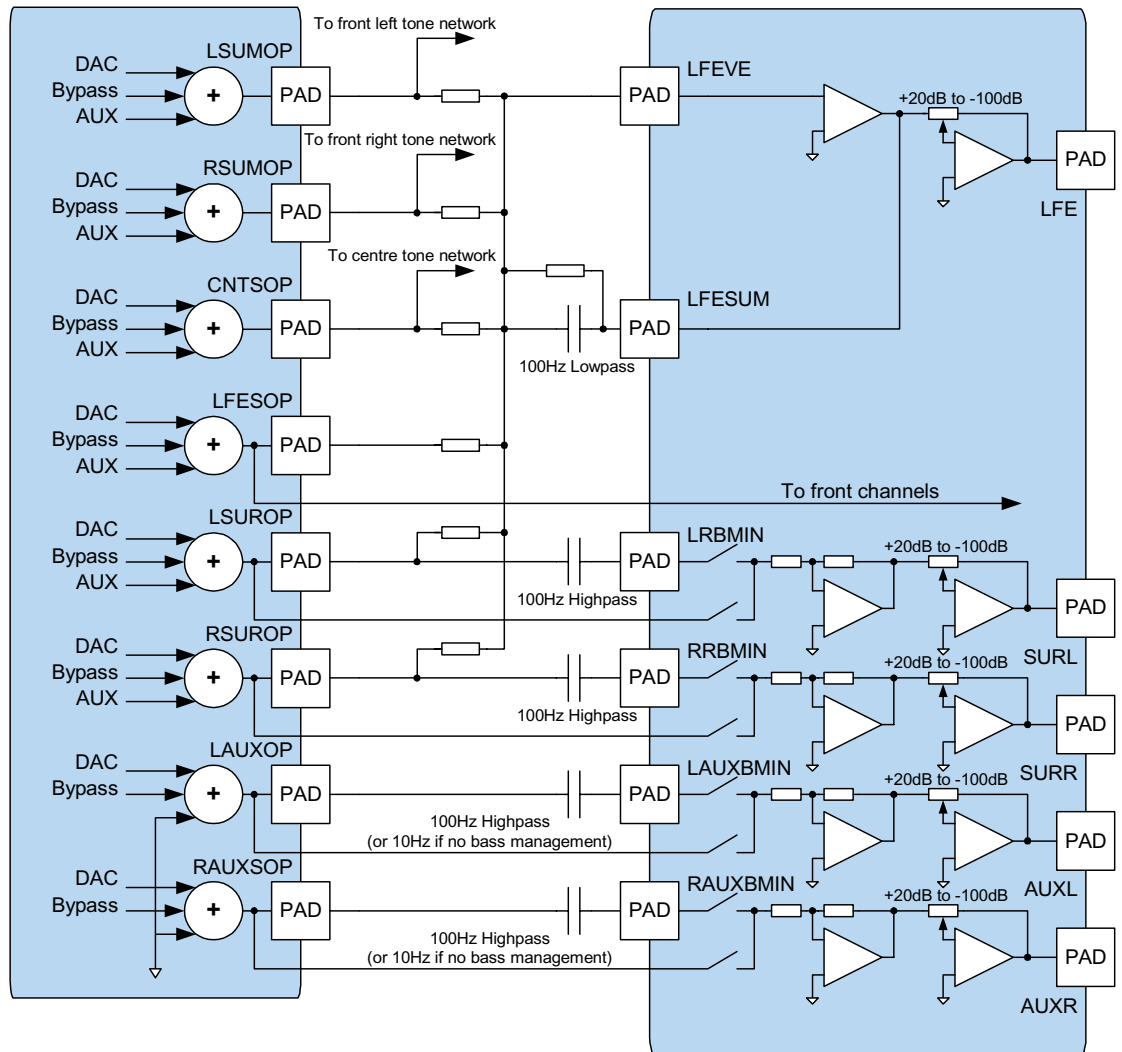

Figure 3 Bass Management Configuration

BASS MANAGEMENT BYPASS

Signal paths are provided for the surround and auxiliary channels which allow the user to bypass the high pass filtering operation and apply the unfiltered signals directly to the analogue volume controls.

REGISTER ADDRESS	BIT	LABEL	DEFAULT	DESCRIPTION
(27h) Bass Management Bypass	0	AUXLBYP	0	Bypass select for AUX left output 0 = Bass managed 1 = Bypass
	1	AUXRBYP	0	Bypass select for AUX right output 0 = Bass managed 1 = Bypass
	2	SURLBYP	0	Bypass select for surround left output 0 = Bass managed 1 = Bypass
	3	SURRBYP	0	Bypass select for surround right output 0 = Bass managed 1 = Bypass

Table 7 Bass Management Bypass Register

HEADPHONE OUTPUT

A stereo headphone output is provided which may be used to buffer out either the front L/R channels, or the AUX L/R channels as required. Control is via the HPSEL bit. An independent volume control is provided for this output.

REGISTER ADDRESS	BIT	LABEL	DEFAULT	DESCRIPTION
(25h) Centre Mixer Control 1	6	HPSEL	0	Controls headphone output MUX:- 0 = FRONT L/R output on headphone channels 1 = AUX L/R output on headphone channels

Table 8 Headphone Source Select

OUTPUT POWERDOWN

The analogue output signal paths are all disabled by default and can be controlled by writing to the appropriate software control register.

REGISTER ADDRESS	BIT	LABEL	DEFAULT	DESCRIPTION
(2Dh) Output Powerdown	0	AUXLPD	1	Auxiliary left output powerdown. 0 = enabled 1 = disabled
	1	AUXRPD	1	Auxiliary right output powerdown. 0 = enabled 1 = disabled
	2	SURLPD	1	Surround left output powerdown. 0 = enabled 1 = disabled
	3	SURRPD	1	Surround Right output powerdown. 0 = enabled 1 = disabled
	4	LFEPD	1	LFE output powerdown. 0 = enabled 1 = disabled
	5	CTRPD	1	Center output powerdown. 0 = enabled 1 = disabled
	6	FRTLPD	1	Front Left output powerdown. 0 = enabled 1 = disabled
	7	FRTRPD	1	Front Right output powerdown. 0 = enabled 1 = disabled
	8	HPPD	1	Headphone output powerdown. 0 = enabled 1 = disabled

Table 9 Output Powerdown Register

DIGITAL AUDIO INTERFACE ROUTING OPTIONS

The WM8777 has extremely flexible digital audio interface routing options which are illustrated in Figure 4. It has an S/PDIF receiver, S/PDIF transmitter and two digital audio interfaces. Each DAC has its own digital input pin PDATAIP1/2/3/4. Internal multiplexors in the primary audio interface (DAC) allow the data received on any DIN pin to be routed to any DAC. Any DIN pin routed to DAC1 is also routed to the S/PDIF and Secondary Audio Interface transmitters. DAC1 may also be used to convert received S/PDIF data to analogue, while DACs 2-4 take data only from the primary audio interface. The primary audio interface can output ADC data, received S/PDIF data, or data from the secondary audio interface on the PDATAOP pin. The primary audio interface can output ADC data, received S/PDIF data and data received through PDATAIP1-4 on the SDATAOP pin. The S/PDIF transmitter can output S/PDIF received data, and converts ADC data and data from both audio interfaces into S/PDIF format and outputs them on SPDIFOP.

The secondary audio interface can output ADC data, received S/PDIF data and data received through PDATAIP1-4 on the SDATAOP pin. The S/PDIF transmitter can output S/PDIF received data, and converts ADC data and data from both audio interfaces into S/PDIF format and outputs them on SPDIFOP.

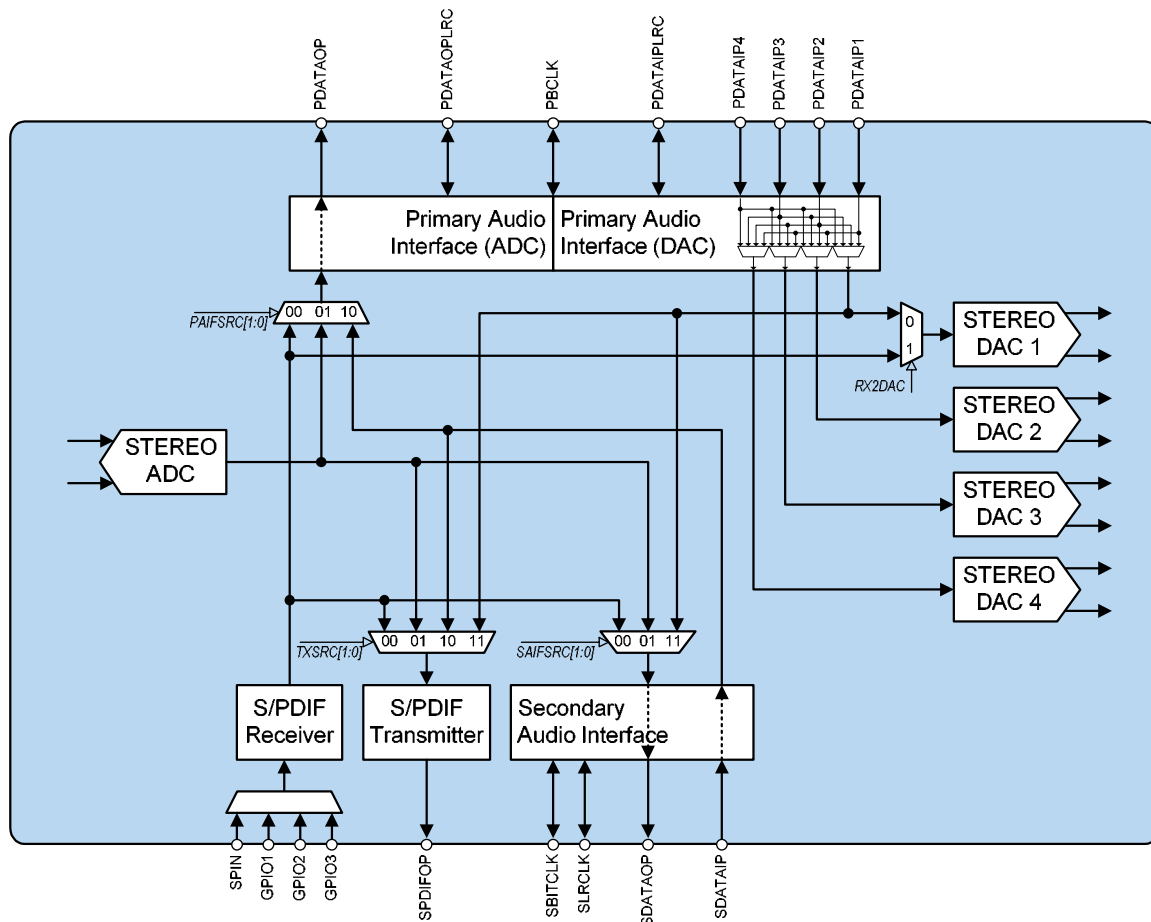

Figure 4 WM8777 Digital Routing Diagram

REGISTER ADDRESS	BIT	LABEL	DEFAULT	DESCRIPTION
R65 (41h) Interface Source Select	0	RX2DAC	0	Received S/PDIF PCM data to DAC. 0 = DAC1 takes data from Primary Audio Interface. 1 = DAC1 takes data from S/PDIF receiver. Note: If DACs 2, 3 and 4 are disabled, DAC1 uses the subframe rate of the S/PDIF input with respect to any selected MCLK. PLL clock should be selected to set the f_s mode. If DAC 2, 3 or 4 are enabled, the user must ensure that DACLRC and the S/PDIF subframe are operating at the same rate; any difference will cause a sample slip on DAC1.
	2:1	TXSRC[1:0]	00	S/PDIF Transmitter Data Source. 00 = S/PDIF received data. 01 = ADC digital output data. 10 = Secondary Audio Interface received data 11 = DAC Audio Interface Received data. Note: The output rate is determined by the source of the data to be transmitted. The ADC outputs S/PDIF at a rate determined by LRCLK.
	5:4	PAIFSRC[1:0]	01	Audio Interface output source 00 = S/PDIF received data 01 = ADC digital output data 10 = Secondary Audio Interface received data 11 = Power-down Primary Audio Interface Transmitter Note: for cases 00 and 10, the user must ensure that the source rate matches the transmit rate; any difference will cause samples to be lost. For optimum performance, the PAIF should be operated in master mode, with the master clock source the same as the PAIF source.
	7:6	SAIFSRC[1:0]	00	Secondary Audio Interface Transmitter Data Source. 00 = S/PDIF received data. 01 = ADC digital output data. 10 = Power-down Secondary Audio Interface Transmitter 11 = Primary Audio Interface received data. Note: for cases 00 and 11, the user must ensure that the source rate matches the transmit rate; any difference will cause samples to be lost. For case 01, if PAIFSRC is not also 01, the ADC operation rate is set by the SLRC and ADCCLKSRC/PLL2ADC register bits.

Table 10 Interface Output Selection Register

CONTROL INTERFACE OPERATION

The WM8777 is controlled using a 2-wire (plus readback pin) or 3-wire (plus readback pin) SPI compatible serial interface.

The interface configuration is determined by the state of the GPIO/MODE pin on power up. If the GPIO/MODE pin is low while the power on reset is being applied internally, the 2-wire configuration is selected. If GPIO/MODE is high while the power on reset is being applied internally, the 3-wire configuration is selected - see table 11.

The control interface is 5V tolerant, meaning that the control interface input signals CSB, SCLK and SDIN may have an input high level of 5V while DVDD is 3V. Input thresholds are determined by DVDD.

GPIO/MODE AT POWER UP	CONTROL
Low	2-wire
High	3-wire

Table 11 Control Interface Selection

3-WIRE (SPI COMPATIBLE) SERIAL CONTROL MODE WITH ADDITIONAL READBACK PIN

SDIN is used for the program data, SCLK is used to clock in the program data and CSB is used to latch the program data. SDIN is sampled on the rising edge of SCLK. The 2-wire interface protocol with readback is shown in Figure 5.

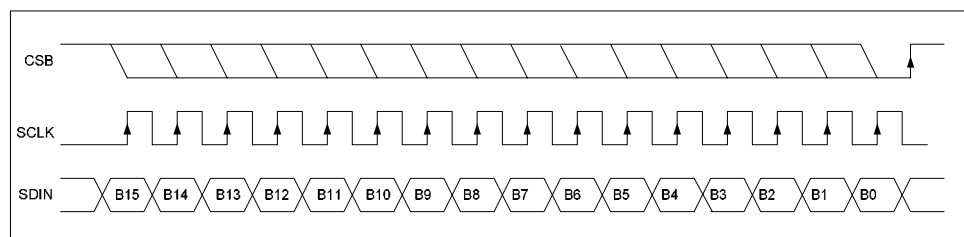

Figure 5 3 Wire SPI Compatible Interface

1. B[15:9] are Control Address Bits
2. B[8:0] are Control Data Bits
3. CSB is edge sensitive – the data is latched on the rising edge of CSB.

3-WIRE REGISTER READBACK

The read-only registers in the S/PDIF section can be read back via the SDOUT pin. To enable readback the READEN3 bit must be set.

REGISTER ADDRESS	BIT	LABEL	DEFAULT	DESCRIPTION
(4Ah) Read-back Control	4	READEN3	0	3-Wire Read-back mode enable. 0 = 3-Wire read-back mode disabled 1 = 3-Wire read-back mode enabled
	5	READEN2	0	2-Wire Read-back mode enable. 0 = 2-Wire read-back mode disabled 1 = 2-Wire read-back mode enabled

Table 12 Readback Control Register

The 3-wire interface readback protocol is shown in Figure 6. Note that the SDOUT pin is tri-state unless CSB is held low, therefore CSB must be held low for the duration of the read.

READEN3=1

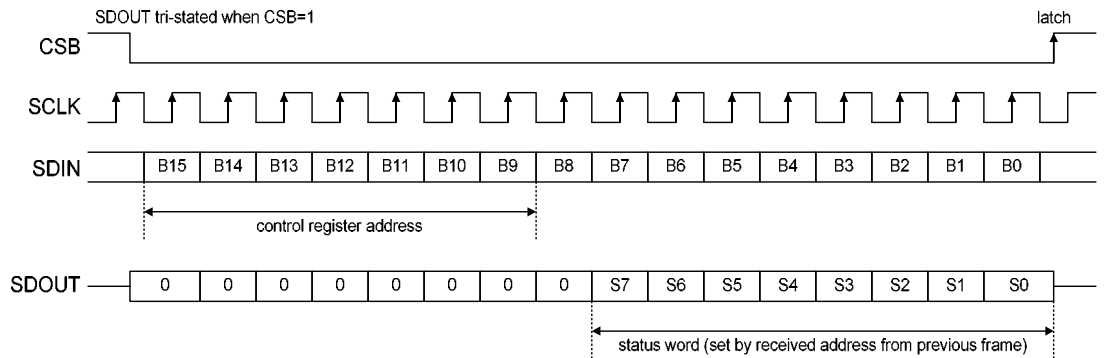

Figure 6 3-Wire SPI Compatible Control Interface Readback

2-WIRE SERIAL CONTROL MODE WITH ADDITIONAL READBCK PIN

The WM8777 supports software control via a 2-wire (plus readback pin) serial bus. Many devices can be controlled by the same bus, and each device has a unique 7-bit address (this is not the same as the 7-bit address of each register in the WM8777).

The controller indicates the start of data transfer with a high to low transition on SDIN while SCLK remains high. This indicates that a device address and data will follow. All devices on the 2-wire bus respond to the start condition and shift in the next eight bits on SDIN (7-bit address + Read/Write bit, MSB first). If the device address received matches the address of the WM8777, the WM8777 responds by pulling SDIN low on the next clock pulse (ACK). If the address is not recognised, the WM8777 returns to the idle condition and wait for a new start condition and valid address.

Once the WM8777 has acknowledged a correct address, the controller sends the first byte of control data (B15 to B8, i.e. the WM8777 register address plus the first bit of register data). The WM8777 then acknowledges the first data byte by pulling SDIN low for one clock pulse. The controller then sends the second byte of control data (B7 to B0, i.e. the remaining 8 bits of register data), and the WM8777 acknowledges again by pulling SDIN low.

The transfer of data is complete when there is a low to high transition on SDIN while SCLK is high. After receiving a complete address and data sequence the WM8777 returns to the idle state and waits for another start condition. If a start or stop condition is detected out of sequence at any point during data transfer (i.e. SDIN changes while SCLK is high), the device jumps to the idle condition.

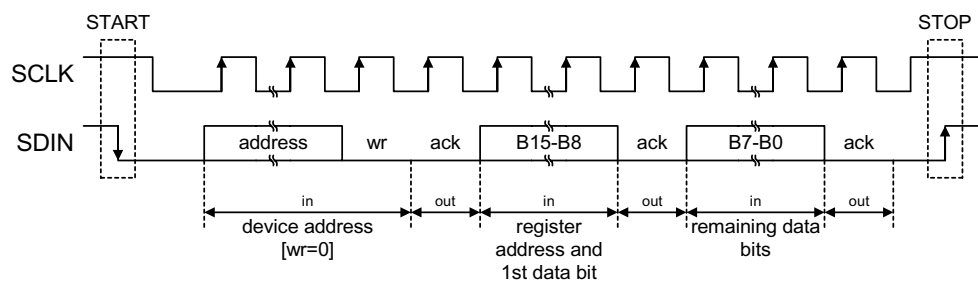

Figure 7 2-Wire Serial Control Interface

The WM8777 has two possible device addresses, which can be selected using the CSBpin.

CSBSTATE	DEVICE ADDRESS IN 2-WIRE MODE
Low or Unconnected	0011010
High	0011011

Table 13 2-Wire MPU Interface Address Selection

2-WIRE SERIAL READBACK

The WM8777 allows readback of certain registers in 2-wire mode, with data output on the SDOUT pin. Readback is set by writing to the Readback Control register (see Table 12) to set READEN2 to 1.

READ STATUS WORD (READEN2=1)

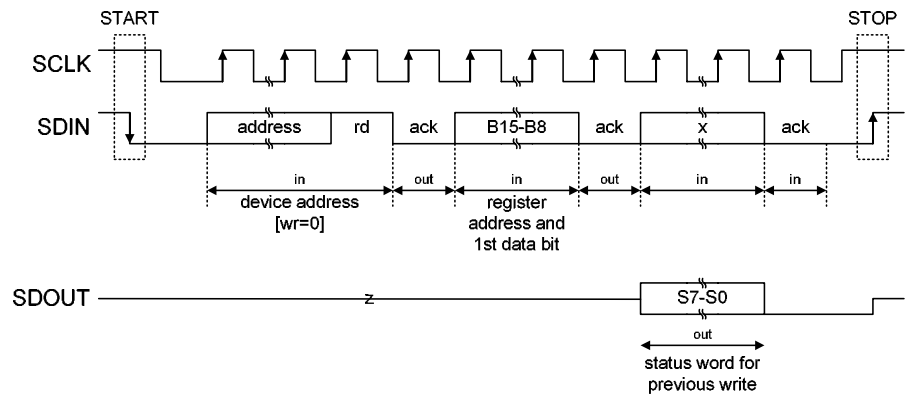

Figure 8 2-Wire Readback

CONTROL INTERFACE TIMING – 3-WIRE MODE

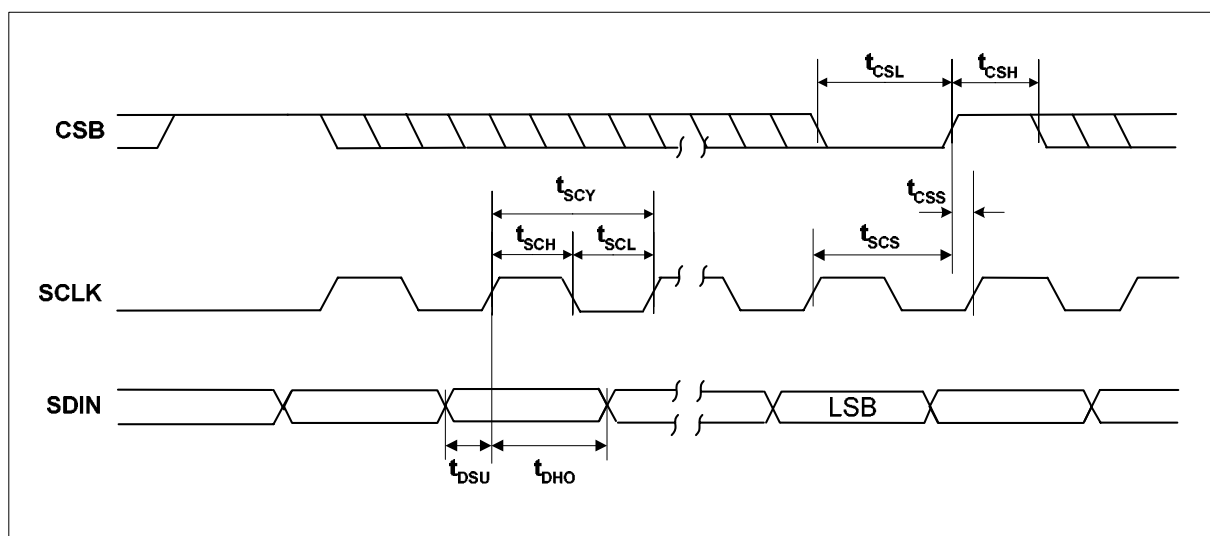

Figure 9 SPI Compatible Control Interface Input Timing

Test Conditions

DVDD = 3.3V, AGND = 0V, DGND = 0V, T_A = +25°C, f_s = 48kHz, MCLK = 256fs, ADC/DAC in Slave Mode unless otherwise stated.

PARAMETER	SYMBOL	MIN	TYP	MAX	UNIT
SCLK rising edge to CSB rising edge	t _{SCS}	60			ns
SCLK pulse cycle time	t _{SCY}	80			ns
SCLK pulse width low	t _{SCL}	30			ns
SCLK pulse width high	t _{SCH}	30			ns
SDIN to SCLK set-up time	t _{DSU}	20			ns
SCLK to SDIN hold time	t _{DHO}	20			ns
CSB pulse width low	t _{CSL}	20			ns
CSB pulse width high	t _{CSH}	20			ns
CSB rising to SCLK rising	t _{CSS}	20			ns

Table 14 SCLK Timing Requirements

CONTROL INTERFACE TIMING – 2-WIRE MODE

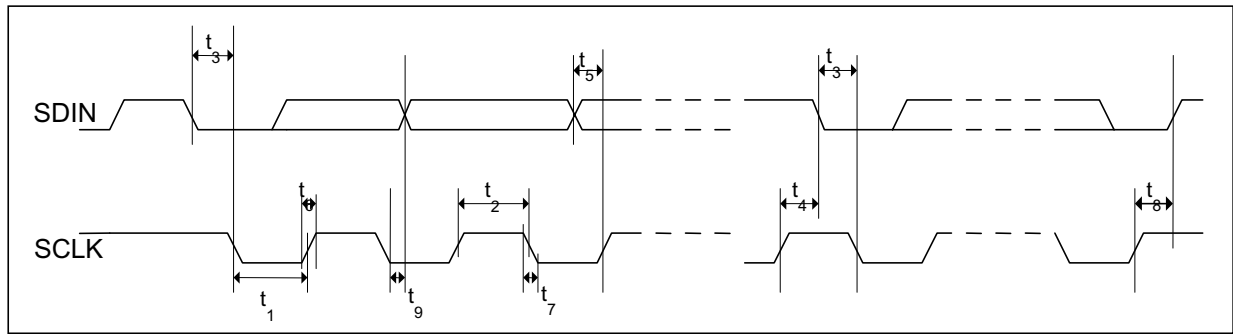

Figure 10 Control Interface Timing – 2-Wire Serial Control Mode (MODE=0)

Test Conditions

AVDD = 5V, DVDD = 3.3V, AGND, DGND = 0V, $T_A = +25^\circ\text{C}$, $f_s = 48\text{kHz}$, MCLK = 256fs unless otherwise stated

PARAMETER	SYMBOL	MIN	TYP	MAX	UNIT
Program Register Input Information					
SCLK Frequency		0		400	kHz
SCLK Low Pulse-Width	t_1	600			ns
SCLK High Pulse-Width	t_2	1.3			us
Hold Time (Start Condition)	t_3	600			ns
Setup Time (Start Condition)	t_4	600			ns
Data Setup Time	t_5	100			ns
SDIN, SCLK Rise Time	t_6			300	ns
SDIN, SCLK Fall Time	t_7			300	ns
Setup Time (Stop Condition)	t_8	600			ns
Data Hold Time	t_9			900	ns
Pulse width of spikes that will be suppressed	t_{ps}	0		5	ns

Table 15 2-wire Control Interface Timing Information

MASTER CLOCK

In a typical digital audio system there is only one central clock source producing a reference clock to which all audio data processing is synchronised. This clock is often referred to as the audio system's Master Clock. The external master system clock can be applied directly through the MCLK input pin with no software configuration necessary. In a system where there are a number of possible sources for the reference clock it is recommended that the clock source with the lowest jitter be used to optimise the performance of the ADC and DAC.

MASTER CLOCK TIMING

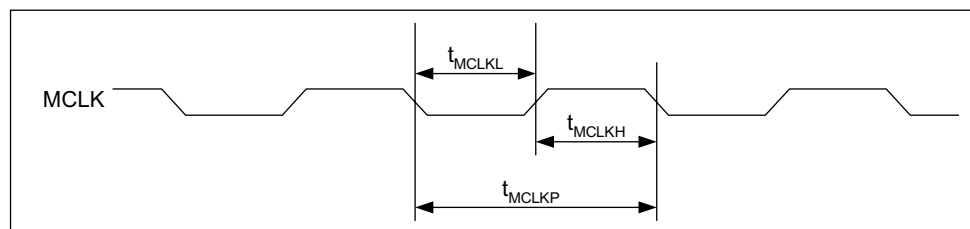

Figure 11 Master Clock Timing Requirements

Test Conditions

DVDD = 3.3V, DGND = 0V, $T_A = +25^\circ\text{C}$, $f_s = 48\text{kHz}$, MCLK = 256fs, ADC/DAC in Slave Mode unless otherwise stated.

PARAMETER	SYMBOL	TEST CONDITIONS	MIN	TYP	MAX	UNIT
System Clock Timing Information						
MCLK System clock pulse width high	t_{MCLKH}		11			ns
MCLK System clock pulse width low	t_{MCLKL}		11			ns
MCLK System clock cycle time	t_{MCLKP}		28			ns
MCLK Duty cycle			40:60		60:40	

Table 16 Master Clock Timing Requirements

The master clock for WM8777 supports DAC and ADC audio sampling rates from 128fs to 1152fs, where fs is the audio sampling frequency (PDATAIPLRC or PDATAOPLRC) typically 32kHz, 44.1kHz, 48kHz, 96kHz, or 192kHz. The master clock is used to operate the digital filters and the noise shaping circuits.

The WM8777 has a master clock detection circuit that automatically determines the relationship between the master clock frequency and the sampling rate (to within +/- 32 system clocks). If there is a greater than 32 clocks error the interface sets itself to the highest rate available, 1152fs. The master clock must be synchronised with PDATAOPLRC/PDATAIPLRC, although the WM8777 is tolerant of phase variations or jitter on this clock.

AUDIO SAMPLING RATES AND AUDIO INTERFACES

DIGITAL AUDIO INTERFACES

The WM8777 has two audio interfaces – a primary audio interface and a secondary audio interface. The primary audio interface has four data inputs (PDATAIP1/2/3/4), one data output (PDATAOP), and is controlled by PBCLK, PDATAOPLRC and PDATAIPLRC clock pins. The secondary audio interface has one input (SDATAIP), one output (SDATAOP) and is controlled by SBCLK and SLRC clock pins.

Both audio interfaces operate in either Slave or Master mode, selectable using the PAIFRX_MS and SMS control bits. In both Master and Slave modes PDATAIP1/2/3/4 and SDATAIP are always inputs to the WM8777 and PDATAOP and SDATAOP are always outputs. The default is Slave mode.

SLAVE MODE

In Slave mode (PAIFRX_MS/SMS=0) PDATAOPLRC, PDATAIPLRC, SLRC, PBCLK and SBCLK are inputs to the WM8777. PDATAIP1/2/3/4, PDATAOPLRC and PDATAIPLRC are sampled by the WM8777 on the rising edge of PBCLK. SDATAIP and SLRC are sampled by the WM8777 on the rising edge of SBCLK. Data output PDATAOP changes on the falling edge of PBCLK and data output on SDATAOP changes on the falling edge of SBCLK. By setting control bit PAIFRX_BCP the polarity of PBCLK may be reversed so that PDATAIP1/2/3/4, PDATAOPLRC and PDATAIPLRC are sampled on the falling edge of PBCLK and PDATAOP changes on the rising edge of PBCLK. Similarly the polarity of SBCLK can be reversed using control bit SBCP.

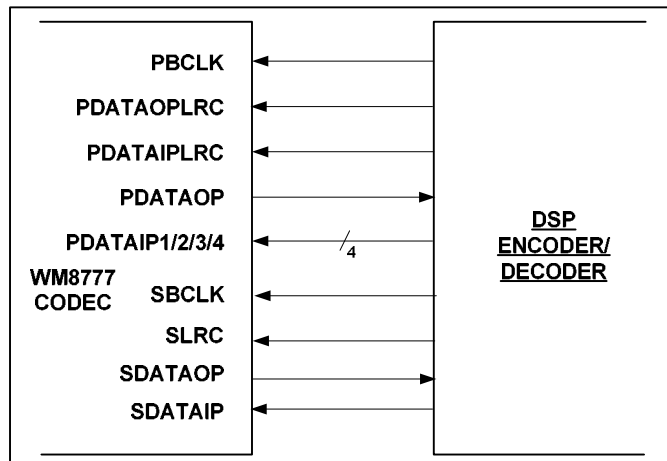

Figure 12 Digital Audio Interface – Slave Mode

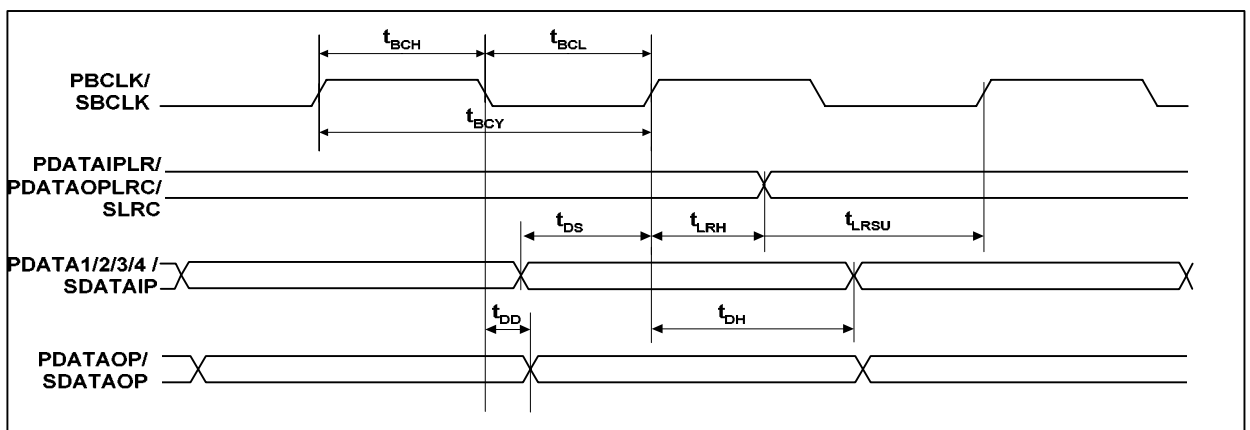

Figure 13 Digital Audio Data Timing – Slave Mode

Test ConditionsDVDD = 3.3V, DGND = 0V, T_A = +25°C, fs = 48kHz, MCLK = 256fs, ADC/DAC in Slave Mode unless otherwise stated.

PARAMETER	SYMBOL	TEST CONDITIONS	MIN	TYP	MAX	UNIT
Audio Data Input Timing Information						
PBCLK cycle time	t _{BCY}		50			ns
PBCLK pulse width high	t _{BCH}		20			ns
PBCLK pulse width low	t _{BCL}		20			ns
PDATAIPLRC/PDATAOPLRC set-up time to PBCLK rising edge	t _{LRSU}		10			ns
PDATAIPLRC/PDATAOPLRC hold time from PBCLK rising edge	t _{LRH}		10			ns
PDATAIP1/2/3/4 set-up time to PBCLK rising edge	t _{DS}		10			ns
PDATAIP1/2/3/4 hold time from PBCLK rising edge	t _{DH}		10			ns
PDATAOP propagation delay from PBCLK falling edge	t _{DD}		0		10	ns

Table 17 Digital Audio Data Timing – Slave Mode

Note: PDATAOPLRC and PDATAIPLRC should be synchronous with MCLK, although the WM8777 interface is tolerant of phase variations or jitter on these signals.

The DACs support system clock to sampling clock ratios of 256fs to 1152fs when the DAC signal processing of the WM8777 is programmed to operate at 128 times oversampling rate (DACOSR=0). The DACs support ratios of 128fs and 192fs when the WM8777 is programmed to operate at 64 times oversampling rate (DACOSR=1).

The ADC supports system clock to sampling clock ratios of 128fs to 1152fs. The signal processing for the WM8777 ADC typically operates at an oversampling rate of 128fs. For ADC operation at 96kHz in 256fs or 384fs mode it is recommended that the user set the ADCOSR bit. This changes the ADC signal processing oversample rate from 128fs to 64fs. For ADC operation at 192kHz in 128fs or 192fs mode it is recommended that the user set the ADCOSR bit. This changes the ADC signal processing oversample rate from 64fs to 32fs.

Table 18 shows the typical system clock frequencies for ADC operation at both 128 times oversampling rate (ADCOSR=0) and 64 times oversampling rate (ADCOSR=1), and DAC operation at 128 times oversampling rate (DACOSR=0). Table 19 shows typical system clock frequencies for ADC operation at 32/64 times oversampling rate (ADCOSR=1), and DAC operation at 64 times oversampling rate (DACOSR =1).

SAMPLING RATE (PDATAIPLRC/ PDATAOPLRC)	System Clock Frequency (MHz)				
	256fs	384fs	512fs	768fs	1152fs
32kHz	8.192	12.288	16.384	24.576	36.864
44.1kHz	11.2896	16.9340	22.5792	33.8688	Unavailable
48kHz	12.288	18.432	24.576	36.864	Unavailable
96kHz	24.576	36.864	Unavailable	Unavailable	Unavailable

Table 18 ADC and DAC system clock frequencies versus sampling rate. (ADC operation at either 128 times oversampling rate (ADCOSR=0) or 64 times oversampling rate (ADCOSR=1), DAC operation at 128 times oversampling rate, DACOSR=0)

SAMPLING RATE (PDATAIPLRC/ PDATAOPLRC)	System Clock Frequency (MHz)	
	128fs	192fs
96kHz	12.288	18.432
192kHz	24.576	36.864

Table 19 ADC and DAC system clock frequencies versus sampling rate. (ADC operation at 32/64 times oversampling rate (ADCOSR=1), DAC operation at 64 times oversampling rate (DACOSR=1))

MASTER MODE

In Master mode PBCLK, PDATAIPLRC, PDATAOPLRC, SLRC and SBCLK are generated by the WM8777.

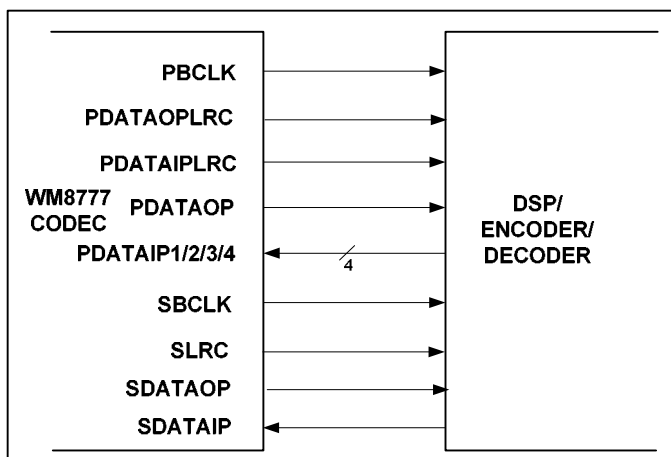

Figure 14 Audio Interface - Master Mode

The frequencies of PDATAOPLRC, PDATAIPLRC and SLRC are set by setting the required ratio of MCLK to PDATAIPLRC, PDATAOPLRC and SLRC using the PAIFRX_RATE, PAIFTX_RATE and SAIFRATE control bits respectively, see Table 20.

PAIFTX_RATE[2:0]/ PAIFRX_RATE[2:0]	MCLK : PDATAOPLRC/PDATAIPLR C/SLRC RATIO
000	128fs
001	192fs
010	256fs
011	384fs
100	512fs
101	768fs
110	1152fs

Table 20 Master Mode MCLK:LRCLK Ratio Select

Table 21 shows the settings for PAIFTX_RATE, PAIFRX_RATE and SAIFRATE for common sample rates and MCLK frequencies.

SAMPLING RATE (PDATAIPLRC/ PDATAOPLRC)	SYSTEM CLOCK FREQUENCY (MHZ)						
	128fs	192fs	256fs	384fs	512fs	768fs	1152fs
	PAIFTX_RATE/ PAIFRX_RATE/ SAIFRATE =000	PAIFTX_RATE/ PAIFRX_RATE/ SAIFRATE =001	PAIFTX_RATE/ PAIFRX_RATE/ SAIFRATE =010	PAIFTX_RATE/ PAIFRX_RATE/ SAIFRATE =011	PAIFTX_RATE/ PAIFRX_RATE/ SAIFRATE =100	PAIFTX_RATE/ PAIFRX_RATE/ SAIFRATE =101	PAIFTX_RATE/ PAIFRX_RATE/ SAIFRATE =110
32kHz	4.096	6.144	8.192	12.288	16.384	24.576	36.864
44.1kHz	5.6448	8.467	11.2896	16.9340	22.5792	33.8688	Unavailable
48kHz	6.144	9.216	12.288	18.432	24.576	36.864	Unavailable
96kHz	12.288	18.432	24.576	36.864	Unavailable	Unavailable	Unavailable
192kHz	24.576	36.864	Unavailable	Unavailable	Unavailable	Unavailable	Unavailable

Table 21 Master Mode ADC/PDATAIPLRC Frequency Selection

PBCLK is also generated by the WM8777. The frequency of PBCLK depends on the mode of operation. In 128/192fs modes (PAIFTX_RATE/PAIFRX_RATE=000 or 001) PBCLK = MCLK/2. In 256/384/512/768/1152fs modes (PAIFTX_RATE/PAIFRX_RATE=010 or 011 or 100 or 101 or 110) PBCLK = MCLK/4. However if DSP mode is selected as the audio interface mode then PBCLK=MCLK. This is to ensure that there are sufficient PBCLKs to clock in all eight channels. Note that DSP mode cannot be used in 128fs mode for word lengths greater than 16-bits or in 192fs mode for word lengths greater than 24 bits.

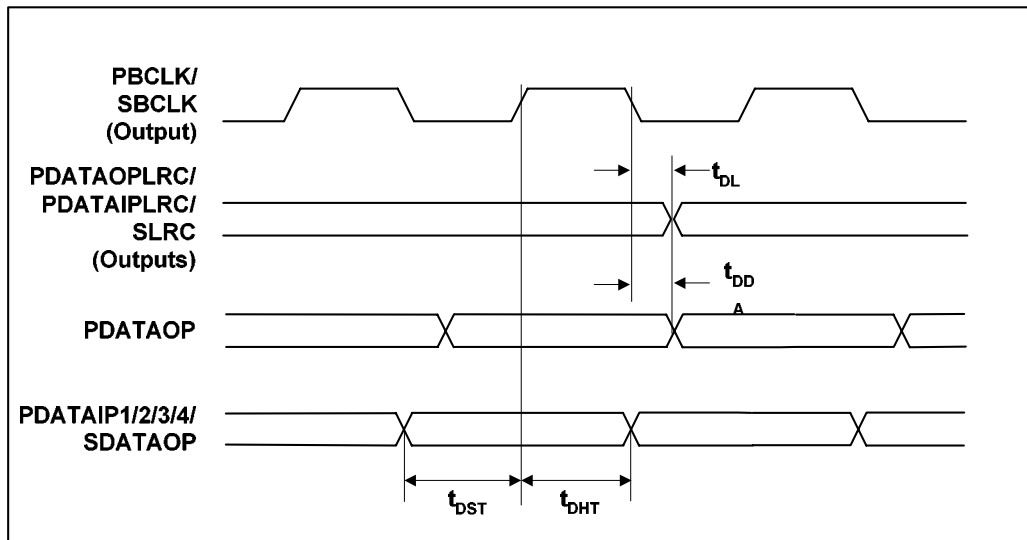

Figure 15 Digital Audio Data Timing – Master Mode

Test Conditions

DVDD = 3.3V, DGND = 0V, TA = +25°C, fs = 48kHz, MCLK = 256fs, ADC/DAC in Slave Mode unless otherwise stated.

PARAMETER	SYMBOL	TEST CONDITIONS	MIN	TYP	MAX	UNIT
Audio Data Input Timing Information						
PDATAOPLRC/PDATAIPLRC propagation delay from PBCLK falling edge	t _{DL}		0		10	ns
PDATAOP propagation delay from PBCLK falling edge	t _{DDA}		0		10	ns
PDATAIP1/2/3/4 setup time to PBCLK rising edge	t _{DST}		10			ns
PDATAIP1/2/3/4 hold time from PBCLK rising edge	t _{DHT}		10			ns

Table 22 Digital Audio Data Timing – Master Mode

MASTER MODE REGISTERS

Control bit PAIFRX_MS selects between primary audio interface Master and Slave Modes. Control bit SMS selects between secondary audio interface master and slave modes.

REGISTER ADDRESS	BIT	LABEL	DEFAULT	DESCRIPTION
(19h) Master Mode Control	7	PAIFTX_MS	0	Master/Slave Interface mode select. If ADCCLKSRC is set high then this register control whether the ADC clocks are in master or slave mode/ 0 = Slave Mode – PDATAOPLRC and ADCPBCLK are inputs 1 = Master Mode – PDATAOPLRC and ADCPBCLK are outputs
	8	PAIFRX_MS	0	Maser/Slave interface mode select 0 = Slave Mode – PDATAOPLRC, PDATAIPLRC and PBCLK are inputs 1 = Master Mode – PDATAOPLRC, PDATAIPLRC and PBCLK are outputs Note if ADCCLKSRC is set high then this register only controls PDATAIPLRC and PBCLK.
(3Fh) Secondary Interface Master Mode Control	3	SMS	0	Master/Slave interface mode select 0 = Slave Mode – SLRC and SBCLK are inputs 1 = Master Mode – SLRC and SBCLK are outputs

Table 23 Master Mode Registers

In Master mode the WM8777 generates PDATAOPLRC, PDATAIPLRC and PBCLK. These clocks are derived from master clock and the ratio of MCLK to PDATAOPLRC and PDATAIPLRC are set by PAIFTX_RATE, PAIFRX_RATE and SAIFRATE.

REGISTER ADDRESS	BIT	LABEL	DEFAULT	DESCRIPTION
(19h) Master Mode Control	2:0	PAIFTX_RATE [2:0]	010	Master Mode MCLK:LRCLK ratio select: 000 = 128fs 001 = 192fs 010 = 256fs 011 = 384fs 100 = 512fs 101 = 768fs 110 = 1152fs
	6:4	PAIFRX_RATE [2:0]	010	
(3Fh) Secondary Interface Master Mode Control	2:0	SAIFRATE [2:0]	010	
(3Fh) Secondary Interface	5:4	SAIFCLKSRC[1:0]	00	Audio interface master clock source when SMS is 1. 00 = MCLK 01 = GPIO (If ADCCLKSRC is set) 10 = PLL clock 11 = PLL clock

Table 24 Master Mode MCLK:LRCLK Registers

AUDIO INTERFACE FORMATS

Audio data is applied to the WM8777 via the Primary and Secondary Audio Interface. Five popular interface formats are supported:

- Left Justified mode
- Right Justified mode
- I²S mode
- DSP Early mode
- DSP Late mode

All five formats send the MSB first and support word lengths of 16, 20, 24 and 32 bits, with the exception of 32 bit right justified mode, which is not supported.

Audio Data for each stereo channel is time multiplexed with the interface's Left-Right-Clock (PDATAOPLRC/PDATAIPLRC), indicating whether the left or right channel is present. The PDATAOPLRC/PDATAIPLRC is also used as a timing reference to indicate the beginning or end of the data words.

In left justified, right justified and I²S modes, the minimum number of PBCLKs per LRCLK period is 2 times the selected word length. LRCLK must be high for a minimum of word length PBCLKs and low for a minimum of word length PBCLKs. Any mark to space ratio on LRCLK is acceptable provided the above requirements are met. The Primary Audio interface has Left-Right-Clocks PDATAOPLRC and PDATAIPLRC, and Bit-Clock PBCLK. The Secondary Audio Interface has Left-Right-Clock SLRC, and Bit-Clock SBCLK.

In DSP early or DSP late mode, all 8 DAC channels are time multiplexed onto PDATAIP1. PDATAIPLRC is used as a frame sync signal to identify the MSB of the first word. The minimum number of PBCLKs per PDATAIPLRC period is 8 times the selected word length. Any mark to space ratio is acceptable on PDATAIPLRC provided the rising edge is correctly positioned. The ADC data may also be output in DSP early or late modes, with PDATAOPLRC used as a frame sync to identify the MSB of the first word. The minimum number of PBCLKs per PDATAOPLRC period is 2 times the selected word length. The Secondary Audio Interface also supports DSP modes with SLRC used as a frame sync and data input on SDATAIP, and data output on SDATAOP. The minimum number of SBCLKs per SLRC period is 2 times the selected word length.

LEFT JUSTIFIED MODE

In left justified mode, the MSB of the input data (PDATAIP/SDATAIP) is sampled by the WM8777 on the first rising edge of PBCLK/SBCLK following a LRCLK transition. The MSB of the output data (PDATAOP/SDATAOP) changes on the same falling edge of PBCLK as SLRC, and may be sampled on the next rising edge of PBCLK. LRCLKs are high during the left samples and low during the right samples.

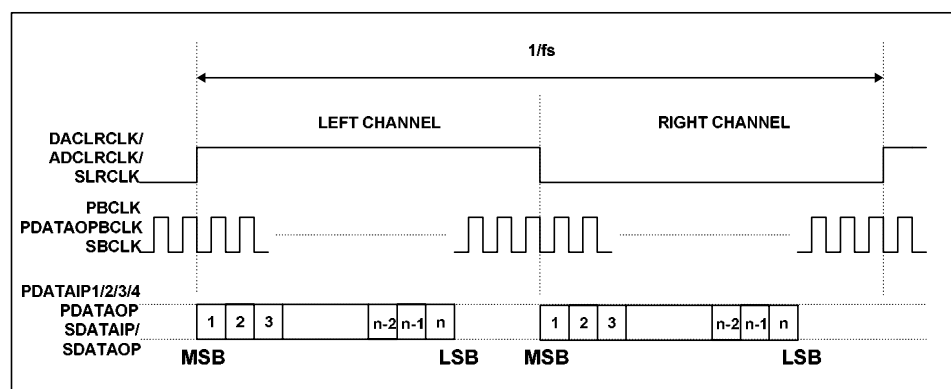

Figure 16 Left Justified Mode Timing Diagram

RIGHT JUSTIFIED MODE

In right justified mode, the LSB of the input data (PDATAIP/SDATAIP) is sampled by the WM8777 on the rising edge of PBCLK/SBCLK preceding a LRCLK transition. The LSB of the output data (PDATAOP/SDATOP) changes on the falling edge of PBCLK preceding a LRCLK transition, and may be sampled on the next rising edge of PBCLK. LRCLKs are high during the left samples and low during the right samples (Figure 17).

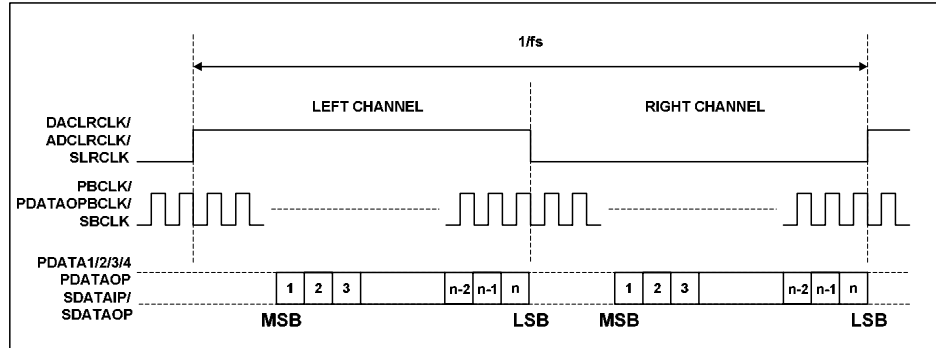

Figure 17 Right Justified Mode Timing Diagram

I²S MODE

In I²S mode, the MSB of the input data is sampled by the WM8777 on the second rising edge of PBCLK/SBCLK following a LRCLK transition. The MSB of the output data changes on the first falling edge of PBCLK following an LRCLK transition, and may be sampled on the next rising edge of PBCLK. LRCLKs are low during the left samples and high during the right samples.

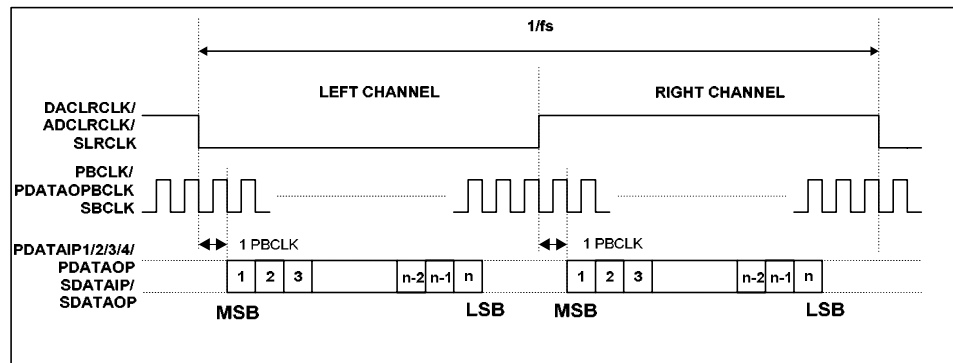

Figure 18 I²S Mode Timing Diagram

DSP EARLY MODE

In DSP early mode, the MSB of DAC channel 1 left data is sampled by the WM8777 on the second rising edge on PBCLK following a PDATAIPLRC rising edge. DAC channel 1 right and DAC channels 2, 3 and 4 data follow DAC channel 1 left data (Figure 19).

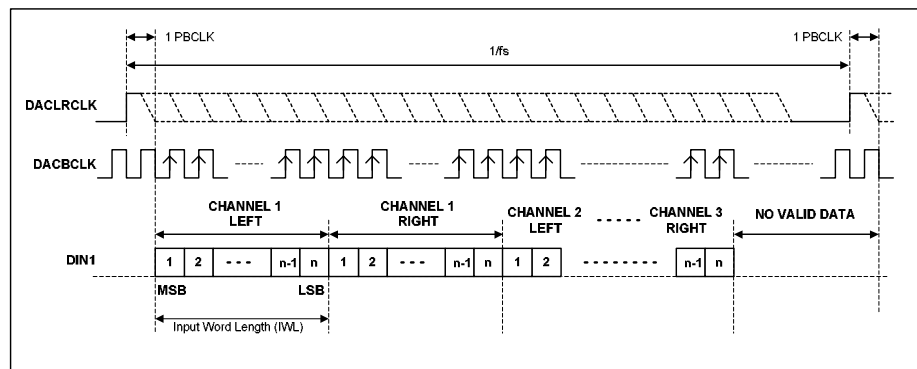

Figure 19 DSP Early Mode Timing Diagram – DAC Data Input

The MSB of the left channel ADC data is output on PDATAOP and changes on the first falling edge of PBCLK following a low to high PDATAOPLRC transition and may be sampled on the rising edge of PBCLK. The right channel ADC data is contiguous with the left channel data (Figure 20).

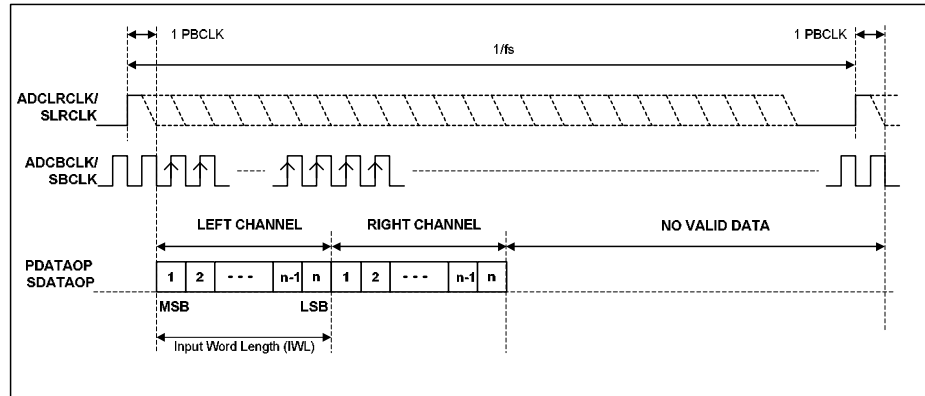

Figure 20 DSP Early Mode Timing Diagram – ADC Data Output

DSP LATE MODE

In DSP late mode, the MSB of DAC channel 1 left data is sampled by the WM8777 on the first PBCLK rising edge following a PDATAIPLRC rising edge. DAC channel 1 right and DAC channels 2, 3 and 4 data follow DAC channel 1 left data (Figure 21).

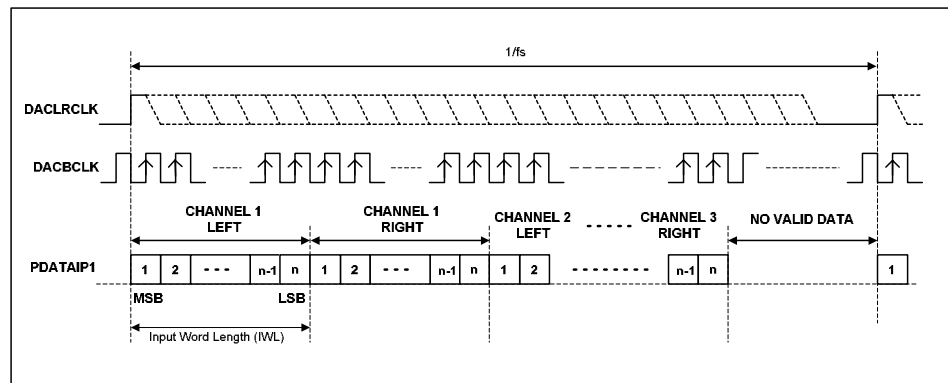

Figure 21 DSP Late Mode Timing Diagram – DAC Data Input

The MSB of the left channel ADC data is output on PDATAOP and changes on the same falling edge of PBCLK as the low to high PDATAOPLRC transition and may be sampled on the rising edge of PBCLK. The right channel ADC data is contiguous with the left channel data (Figure 22).

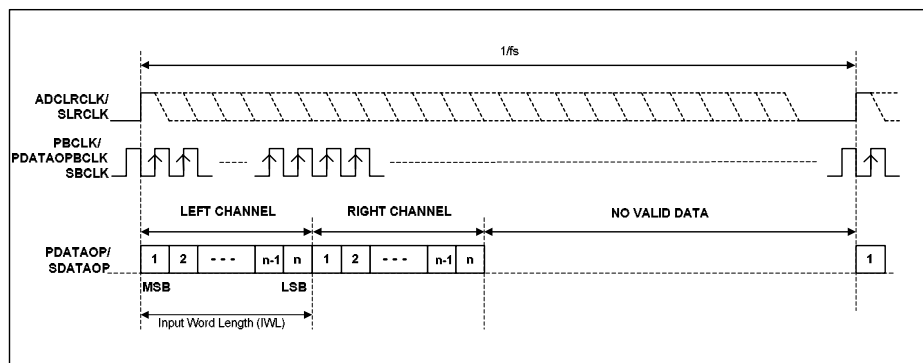

Figure 22 DSP Late Mode Timing Diagram – ADC Data Output

In both early and late DSP modes, DACL1 is always sent first, followed immediately by DACR1 and the data words for the other 6 channels. No PBCLK edges are allowed between the data words. The word order is DAC1 left, DAC1 right, DAC2 left, DAC2 right, DAC3 left, DAC3 right, DAC4 left, DAC4 right. For DSP modes the Secondary Audio Interface exhibits similar timing to the ADC where data is input on SDATAIP, and output on SDATAOP.

DIGITAL AUDIO INTERFACE CONTROL REGISTERS

Interface format for primary and secondary interfaces are selected via the PAIFRX_FMT register bits:

REGISTER ADDRESS	BIT	LABEL	DEFAULT	DESCRIPTION
(18h) Primary Interface Control (RX)	1:0	PAIFRX_FMT [1:0]	10	Interface Format Select 00 = right justified mode 01 = left justified mode 10 = I ² S mode 11 = DSP (early or late) mode
(1Bh) Primary Interface Control (TX)	1:0	PAIFTX_FMT [1:0]	10	
(3Eh) Secondary Interface Control	1:0	SAIF_FMT [1:0]	10	

Table 25 Format Registers

In left justified, right justified or I²S modes, the PAIFRX_LRP register bit controls the polarity of PDATAIPLRC/PDATAOPLRC/SLRC. If this bit is set high, the expected polarity of PDATAIPLRC/PDATAOPLRC/SLRC will be the opposite of that shown in Figure 16, Figure 17 and Figure 18.

Note that if this feature is used as a means of swapping the left and right channels, a 1 sample phase difference will be introduced. In DSP modes, the PAIFRX_LRP register bit is used to select between early and late modes.

REGISTER ADDRESS	BIT	LABEL	DEFAULT	DESCRIPTION
(18h) Primary Interface Control (RX)	2	PAIFRX_LRP	0	In LEFT/RIGHT/I²S modes: PDATAOPLRC/PDATAIPLRC/SLRC Polarity (normal) 0 = normal LRCLK polarity 1 = inverted LRCLK polarity In DSP mode: 0 = Early DSP mode 1 = Late DSP mode
(1Bh) Primary Interface Control (TX)	2	PAIFTX_LRP	0	
(3Eh) Secondary Interface Control	2	SAIF_LRP	0	

Table 26 LRCLK Polarity Registers

By default, PDATAIPLRC, PDATAOPLRC, SLRC, PDATAIP1/2/3/4 and SDATAIP are sampled on the rising edge of PBCLK/SBCLK and should ideally change on the falling edge. Data sources that change PDATAIPLRC, PDATAOPLRC, SLRC, PDATAIP1/2/3/4 and SDATAOP on the rising edge of PBCLK/SBCLK can be supported by setting the PAIFRX_BCP register bit. Setting PAIFRX_BCP to 1 inverts the polarity of PBCLK/SBCLK to the inverse of that shown in Figure 19, Figure 20, Figure 21 and Figure 22.

REGISTER ADDRESS	BIT	LABEL	DEFAULT	DESCRIPTION
(18h) Primary Interface Control (RX)	3	PAIFRX_BCP	0	PBCLK/SBCLK Polarity (DSP modes) 0 = normal PBCLK polarity 1 = inverted PBCLK polarity
(1Bh) Primary Interface Control (TX)	3	PAIFTX_BCP	0	
(3Eh) Secondary Interface Control	3	SAIF_BCP	0	

Table 27 PBCLK Polarity Registers

The PAIFRX_WL[1:0] bits are used to control the input word length.

Note: If 32-bit mode is selected in right justified mode, the WM8777 defaults to 24 bits.

REGISTER ADDRESS	BIT	LABEL	DEFAULT	DESCRIPTION
(18h) Primary Interface Control (RX)	5:4	PAIFRX_WL[1:0]	10	Input Word Length 00 = 16 bit data 01 = 20 bit data 10 = 24 bit data 11 = 32 bit data
(1Bh) Primary Interface Control (TX)	5:4	PAIFTX_WL [1:0]	10	
(3Eh) Secondary Interface Control	5:4	SAIF_WL [1:0]	10	

Table 28 Word Length Registers

In all modes, the data is signed 2's complement. The digital filters always input 24-bit data. If the DAC is programmed to receive 16 or 20 bit data, the WM8777 pads the unused LSBs with zeros. If the DAC is programmed into 32 bit mode, the 8 LSBs are ignored.

Note: In 24 bit I²S mode, any width of 24 bits or less is supported provided that LRCLK is high for a minimum of 24 PBCLKs and low for a minimum of 24 PBCLKs. If exactly 32 bit clocks occur in one left/right clock (16 high, 16 low) the chip will auto detect and run a 16 bit data mode.

POWERDOWN MODES

The WM8777 has powerdown control bits allowing specific parts of the WM8777 to be powered down when not in use. The 6-channel input source selector and input buffer may be powered down using control bit AINPD. When AINPD is set all inputs to the source selector (AIN1L/R to AIN6L/R) are switched to a buffered VMIDADC and the ADC is also powered off. The control bit ADCPO powers off the ADC.

The four stereo DACs each have a separate powerdown control bit, DACPD[3:0] allowing individual stereo DACs to be powered down when not in use. The analogue output mixers and PGAs may also be powered down by setting OUTPD1/2/3/4. OUTPD1/2/3/4 also switch the analogue outputs VOUTL/R to VMIDDAC to maintain a dc level on the output. SPDIFTXD and SPDIFRXD will powerdown the S/PDIF transmitter and receiver.

Setting all of AINPD, ADCPD, DACPD[3:0], SPDIFTXD, SPDIFRXD and OUTPD[3:0] will powerdown everything except the references VMIDADC, ADCREF and VMIDDAC. These may be powered down by setting PDWN. Setting PDWN will override all other powerdown control bits. It is recommended that the 6-channel input mux and buffer, ADC, DAC and output mixers and PGAs are powered down before setting PDWN. The default is for all powerdown bits to be set except PDWN.

REGISTER ADDRESS	BIT	LABEL	DEFAULT	DESCRIPTION
(1Ah) Powerdown Control	0	PWDN	0	Chip Powerdown Control (works in tandem with the other powerdown registers): 0 = All digital circuits running, outputs are active 1 = All digital circuits in power save mode, outputs muted
	1	ADCPD	1	ADC powerdown: 0 = ADC enabled 1 = ADC disabled
	5:2	DACPD[3:0]	1111	DAC powerdowns (0 = DAC enabled, 1 = DAC disabled) DACPD[0] = DAC1 DACPD[1] = DAC2 DACPD[2] = DAC3 DACPD[3] = DAC4
	6	SPDIFTXD	1	SPDIF_TX powerdown 0 = SPDIF_TX enabled 1 = SPDIF_TX disabled
	7	SPDIFRXD	1	SPDIF_RX powerdown 0 = SPDIF_RX enabled 1 = SPDIF_RX disabled

	8	OSCPD	1	OSC power down 0 = Oscillator enabled 1 = Oscillator disabled
(31h) ADC Mux and Buffer Powerdown Control	8	AINPD	1	Input mux and buffer powerdown 0 = Input mux and buffer enabled 1 = Input mux and buffer powered down
(32h) Output Mux and Powerdown Control 1	7	OUTPD1	1	Mixer Powerdown select 0 = Powerup 1 = Powerdown
	8	OUTPD2	1	Mixer Powerdown select 0 = Powerup 1 = Powerdown
(33h) Output Mux and Powerdown Control 2	7	OUTPD3	1	Mixer Powerdown select 0 = Powerup 1 = Powerdown
	8	OUTPD4	1	Mixer Powerdown select 0 = Powerup 1 = Powerdown
(37h) PLL Control 4	0	PLLPD	1	0 = Enable PLL 1 = Disable PLL
(2Dh) Output Powerdown	0	AUXLPD	1	Auxiliary left output powerdown. 0 = enabled 1 = disabled
	1	AUXRPD	1	Auxiliary right output powerdown. 0 = enabled 1 = disabled
	2	SURLPD	1	Surround left output powerdown. 0 = enabled 1 = disabled
	3	SURRPD	1	Surround Right output powerdown. 0 = enabled 1 = disabled
	4	LFEPD	1	LFE output powerdown. 0 = enabled 1 = disabled
	5	CTRPD	1	Center output powerdown. 0 = enabled 1 = disabled
	6	FRTLPD	1	Front Left output powerdown. 0 = enabled 1 = disabled
	7	FRTRPD	1	Front Right output powerdown. 0 = enabled 1 = disabled
	8	HPPD	1	Headphone output powerdown. 0 = enabled 1 = disabled

R65 (41h) Interface Source Select	5:4	PAIFSRC [1:0]	01	Audio Interface output source 00 = S/PDIF received data 01 = ADC digital output data 10 = Secondary Audio Interface received data 11 = Power-down Primary Audio Interface Transmitter
	7:6	SAIFSRC [1:0]	00	Secondary Audio Interface Transmitter Data Source. 00 = S/PDIF received data. 01 = ADC digital output data. 10 = Power-down Secondary Audio Interface Transmitter 11 = Primary Audio Interface received data.

Table 29 Powerdown Registers

MASTER CLOCK AND PHASE LOCKED LOOP

The WM8777 has an on-chip phase-locked loop (PLL) circuit that can be used to:

- Generate master clocks for the WM8777 audio functions from another external clock.
- Generate a clock for another part of the system from an existing audio master clock.

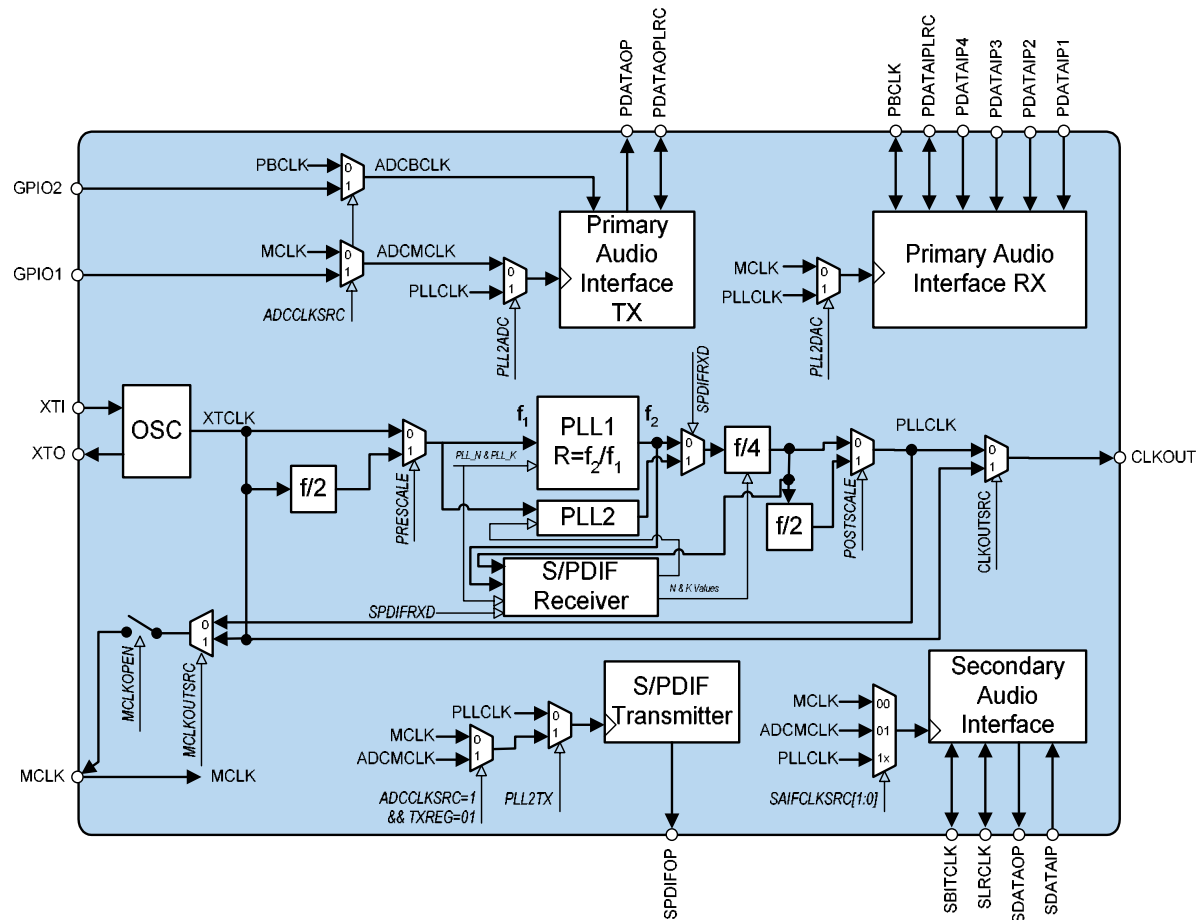

Figure 23 PLL and Clock Select Circuit

The PLL frequency ratio $R = f_2/f_1$ (see Figure 23) can be set using K and N (see :

$$N = \text{int } R$$

$$K = \text{int } (2^{22} (R-N))$$

The PLL circuit is made up of an analogue PLL (PLL1) and a digital PLL (PLL2). N and k values can be set manually for the analogue PLL (PLL1). The S/PDIF receiver monitors the input data stream and constantly varies the N and k values on PLL2 to maintain a stable recovered clock frequency. In order for the S/PDIF receiver to automatically lock to input S/PDIF signal frequencies of 32kHz, 44.1kHz and 48kHz, f_2 of PLL1 (see figure 23) must be in the range of 94.6118MHz. This gives the S/PDIF receiver the maximum pulling range to lock onto the incoming data stream.

Example:

MCLK=12MHz, required clock = 12.288MHz.

R should be chosen to ensure $5 < N < 13$. There is a divide by 4 and a selectable divide by 2 after the PLL which should be set to meet this requirement. Enabling the divide by 2 sets the required $f_2 = 8 \times 12.288\text{MHz} = 98.304\text{MHz}$.

$$R = 98.304 / 12 = 8.192$$

$$N = \text{int } R = 8$$

$$k = \text{int } (2^{22} \times (8.192 - 8)) = 805306 = \text{C49Bah}$$

S/PDIF DATA/CLOCK RECOVERY

The WM8777 uses a patented clock and data recovery scheme that allows an extremely low jitter bandwidth on the output recovered clock. This is done by isolating the clock and data recovery systems.

The data is recovered and stored in a buffer which modifies the frequency of the recovered clock via a filter. This filter controls the jitter bandwidth using the register value FPLL.

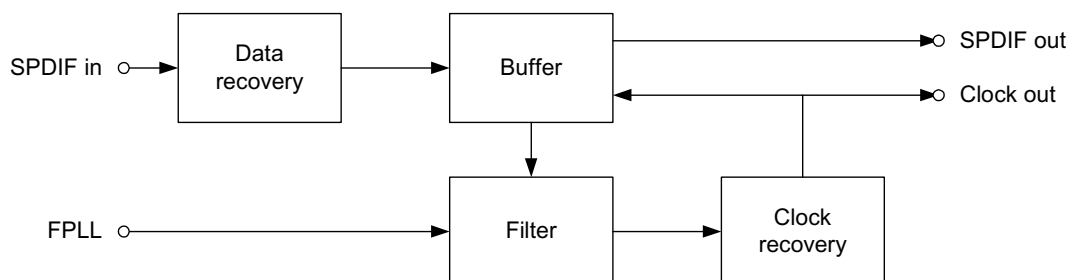

Figure 24 S/PDIF Data and Clock Recovery System

The jitter bandwidth affects the rate at which the clock can change to track the incoming data rate, resulting in a slower tracking time as FPLL is increased. Note that this effect is only apparent on slowly changing input frequencies. Input signals that change frequency by a significant amount, i.e. data rate changes, will cause the system to lose lock and to enter a quick tracking mode which will open the filter bandwidth out to the maximum.

Table 30 lists the cut-off frequencies for the different values of FPLL.

REGISTER ADDRESS	BIT	LABEL	DEFAULT	DESCRIPTION
(42h) S/PDIF Data/Clock Recovery	5:3	FPLL[2:0]	111	-3dB LPF Cut-Off 000 = Invalid 001 = 28.84Hz 010 = 14.92Hz 011 = 7.46Hz 100 = 3.73Hz 101 = 1.87Hz 110 = 0.97Hz 111 = 0.47Hz

Table 30 PLL Frequency Ratio Control

REGISTER ADDRESS	BIT	LABEL	DEFAULT	DESCRIPTION
(18h) Primary Interface Control (RX)	6	MCLKOPEN	0	MCLK pin output enable 0 = MCLK pin is an input 1 = MCLK pin is an output (refer to MCLKOUTSRC below)
	7	MCLKOUTSRC	0	MCLK pin output source 0 = PLL 1 = Crystal clock output.
(34h) PLL Control 1	8:0	PLL_K[8:0]	121 (Hex)	Fractional (K) part of PLL input/output frequency ratio (treat as one 22-digit binary number).
(35h) PLL Control 2	8:0	PLL_K[17:9]	17E (Hex)	
(36h) PLL Control 3	3:0	PLL_K[21:18]	D(Hex)	
(36h) PLL Control 3	4	CLKOUTSRC	0	CLKOUT pin source:- 0 = PLL clock output 1 = Crystal clock output.
	6	PLL2DAC	0	DAC clock source 0 = MCLK pin 1 = PLL clock
	7	PLL2ADC	0	ADC clock source 0 = MCLK or ADCMLCK pin 1 = PLL clock
	8	PLL2TX	1	S/PDIF TX clock source 0 = MCLK or ADCMCLK pin 1 = PLL clock
(37h) PLL Control 4	0	PLLPD	1	0 = Enable PLL 1 = Disable PLL
	1	POSTSCALE	0	0 = no post scale 1 = divide PLL by 2 after PLL
	2	FRAC_EN	0	0 = Integer N only PLL 1 = Integer N and Fractional K PLL
	3	PRESCALE	0	0 = no pre-scale 1 = divide MCLK by 2 prior to PLL
	8:4	PLL_N[4:0]	00000	Integer (N) divisor part of PLL input/output frequency ratio. Use values greater than 5 and less than 13.
(40h) S/PDIF Receiver Input Selector	8	ADCCLKSRC	0	ADC clock source 0 = ADCMCLK is from MCLK pin and ADCPBCLK is from PBCLK pin. 1 = ADCMCLK is from GPIO1, and ADCPBCLK is from GPIO2. (Note that when in this mode RXINSEL must not be set to 01 or 10)

Table 31 PLL Frequency Ratio Control

Note: MCLKOPEN should not be toggled if any part of the WM8777 is actively using MCLK as its clock source.

The PLL performs best when f_2 is around 90MHz. Its stability peaks at N=8. Some example settings are shown below.

XTALC LK (MHz) (F1)	DESIRED OUTPUT (MHz)	F2 (MHz)	PRE SCALE	POST SCALE	R	N (Hex)	K (Hex)
11.91	11.2896	90.3168	0	1	7.5833	7	25545C
11.91	12.288	98.304	0	1	8.2539	8	103FF6
12	11.2896	90.3168	0	1	7.5264	7	21B089
12	12.288	98.304	0	1	8.192	8	C49BA
13	11.2896	90.3168	0	1	6.9474	6	3CA2F4
13	12.288	98.304	0	1	7.5618	7	23F548
14.4	11.2896	90.3168	0	1	6.272	6	116872
14.4	12.288	98.304	0	1	6.8267	6	34E818
19.2	11.2896	90.3168	1	1	9.408	9	1A1CAC
19.2	12.288	98.304	1	1	10.24	A	F5C28
19.68	11.2896	90.3168	1	1	9.1785	9	B6D22
19.68	12.288	98.304	1	1	9.9902	9	3F6017
19.8	11.2896	90.3168	1	1	9.1229	9	7DDCA
19.8	12.288	98.304	1	1	9.9297	9	3B8023
24	11.2896	90.3168	1	1	7.5264	7	21B089
24	12.288	98.304	1	1	8.192	8	C49BA
26	11.2896	90.3168	1	1	6.9474	6	3CA2F4
26	12.288	98.304	1	1	7.5618	7	23F548
27	11.2896	90.3168	1	1	6.6901	6	2C2B30
27	12.288	98.304	1	1	7.2818	7	12089E

Table 32 PLL Frequency Examples

S/PDIF TRANSCEIVER FEATURES

- IEC-60958 compatible with 32 to 96k frames/s support
- Support for Rx and Tx of S/PDIF data
- Clock synthesis PLL with reference clock input and low jitter output
- Input mux with support for up to 4 S/PDIF inputs
- Register controlled Channel Status bit configuration
- Register read-back of recovered Channel Status bits and error flags
- Detection of non-audio data, sample rate, de-emphasis
- Programmable GPO for error flags and frame status flags

An IEC-60958 compatible S/PDIF transceiver is integrated into the WM8777. Operation of the S/PDIF function may be synchronous or asynchronous to the rest of the digital audio circuits.

The receiver performs data and clock recovery, and sends recovered data either off the chip to an external DSP (via Primary or Secondary Audio Interfaces), or if the data is audio PCM, it can route the stereo recovered data to DAC1. The recovered clock may be routed out of the chip onto a pin for external use, and may be used to clock the internal DAC and ADC circuits as required.

The transmitter generates S/PDIF frames where audio data may be sourced from the ADC, S/PDIF Receiver, Primary or Secondary Audio Interfaces.

S/PDIF FORMAT

S/PDIF is a serial, bi-phase-mark encoded data stream. An S/PDIF frame consists of two sub-frames. Each sub-frame is made up of:

- Preamble – a synchronization pattern used to identify the start of a 192-frame block or sub-frame
- 4-bit Auxiliary Data (AUX) – ordered LSB to MSB
- 20-bit Audio Data (24-bit when combined with AUX) – ordered LSB to MSB
- Validity Bit – a 1 indicates invalid data in that sub-frame
- User Bit – over 192-frames, this forms a User Data Block,
- Channel Bit – over 192-frames, this forms a Channel Status Block
- Parity Bit – used to maintain even parity over the sub-frame(except the preamble)

An S/PDIF Block consists of 192 frames. Channel and User blocks are incorporated within the 192-frame S/PDIF Block. For Consumer mode (as in the WM8777) only the first 40-frames are used to make up the Channel and User blocks. Figure 25 illustrates the S/PDIF format.

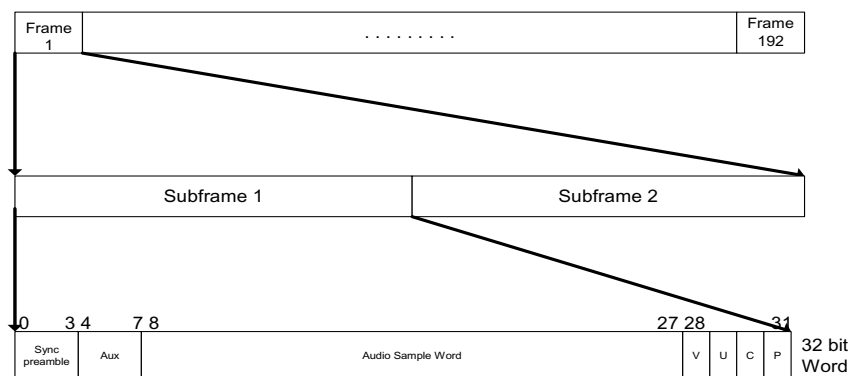

Figure 25 S/PDIF Format

CLOCK RECOVERY AND GENERATION

The circuit comprises data and clock recovery blocks, and a clock synthesis function in the event of no S/PDIF input. As an integral part of these functions, an accurate, stable, crystal derived master clock must be input to the WM8777. This clock may be generated using the WM8777 crystal oscillator circuit, by connecting a suitable crystal across the XIN XOP pins, or else may be applied as a digital input to the XIN pin. This reference clock input may have any frequency from 10MHz up to 27MHz. When S/PDIF signals are being received, the PLL will recover the audio MCLK at a rate of 256fs. In the event of no S/PDIF input, the PLL will continue to synthesise a 128 or 256fs audio clock. If desired the S/PDIF input may be ignored and the PLL instructed to synthesise any desired audio clock rate (depending upon sample rate). The ratio of this audio clock to the reference clock frequency is set by programming the required value over the serial interface. Audio sample rates from 32kHz to 96kHz are supported both by the S/PDIF transceiver and the clock synthesiser.

The reference clock input should be low jitter, hence it is recommended that a crystal connected to WM8777 oscillator is used to generate the clock. In this condition very low jitter audio clocks will be generated, and S/PDIF in-coming clocks will likewise be de-jittered. The WM8777 crystal derived clock, or the PLL derived audio clock, may then be supplied to external circuits as low jitter clock references as required.

S/PDIF TRANSMITTER

The S/PDIF transmitter generates the S/PDIF frames, and outputs on the SPDIFOP pin. The audio data for the frame can be taken from one of four sources, selectable using the TXSRC register. The transmitter can be powered down using the SPDIFTXD register bit.

REGISTER ADDRESS	BIT	LABEL	DEFAULT	DESCRIPTION
(41h) Interface Source Select	2:1	TXSRC[1:0]	00	S/PDIF Transmitter Data Source. 00 = S/PDIF received data. 01 = ADC digital output data. 10 = Secondary Audio Interface received data 11 = Primary Audio Interface Received data.
	3	TXRXTHRU	0	Only used if TXSRC==00. Configures only the Channel Bit in the S/PDIF frame. 0 = Channel data equal to recovered channel data. 1 = Channel data taken from channel status registers.
(1Ah) Powerdown Control	6	SPDIFTXD	1	SPDIF_TX powerdown 0 = SPDIF_TX enabled 1 = SPDIF_TX disabled

Table 33 S/PDIF Tx Control

The WM8777 also transmits the preamble and VUCP bits (Validity, User Data, Channel Status and Parity bits).

VALIDITY BIT

Set to 0 (to indicate valid data) – unless TXSRC=00 (S/PDIF receiver), where Validity is set by the receiver.

USER DATA

Set to 0 as User Data configuration is not supported in the WM8777 – if TXSRC=00 (S/PDIF receiver) User Data is set by the receiver.

CHANNEL STATUS

The Channel Status bits form a 192-frame block - transmitted at 1 bit per sub-frame. Each sub-frame forms its own 192-frame block. The WM8777 is a consumer mode device and only the first 40 bits of the block are used. All data transmitted from the WM8777 is stereo, so the channel status data is duplicated for both channels. The only exception to this is the channel number bits (23:20) which can be changed to indicate if the channel is left or right in the stereo image. Bits within this block can be configured by setting the Channel Bit Control registers (see Tables 28-32). If TXSRC is the S/PDIF receiver, the Channel bits are transmitted with the same values recovered by the receiver – unless TXRXTHRU is set, in which case they are set by the registers.

Note that the WM8777 expects to receive channel status data in consumer format. The channel status bits are defined differently for professional mode. The definitions on the following page do not hold for professional mode.

PARITY BIT

This bit maintains even parity for data as a means of basic error detection. It is generated by the transmitter.

REGISTER ADDRESS	BIT	LABEL	CHANNEL STATUS BIT	DEFAULT	DESCRIPTION
(39h) S/PDIF Transmitter Channel Bit Control 1	0	CON/PRO	0	0	0 = Consumer Mode 1 = Professional Mode (not supported by WM8777)
	1	AUDIO_N	1	0	0 = S/PDIF transmitted data is audio PCM. 1 = S/PDIF transmitted data is not audio PCM.
	2	CPY_N	2	0	0 = Transmitted data has copyright asserted. 1 = Transmitted data has no copyright assertion.
	5:3	PREEMPH [2:0]	5:3	000	000 = Data from Audio interface has no pre-emphasis. 001 = Data from Audio interface has pre-emphasis. 010 = Reserved (Audio interface has pre-emphasis). 011 = Reserved (Audio interface has pre-emphasis). All other modes are reserved and should not be used.
	7:6	CHSTMODE [1:0]	7:6	00	S/PDIF Channel status bits. 00 = Only valid mode for consumer applications. All other modes are reserved.

Table 34 S/PDIF Tx Channel Bit Control 1

REGISTER ADDRESS	BIT	LABEL	CHANNEL STATUS BIT	DEFAULT	DESCRIPTION
(3Ah) S/PDIF Transmitter Channel Bit Control 2	7:0	CATCODE [7:0]	15:8	00000000	Category Code. Refer to S/PDIF specification for details. 00h indicates "general" mode.

Table 35 S/PDIF Tx Channel Bit Control 2

REGISTER ADDRESS	BIT	LABEL	CHANNEL STATUS BIT	DEFAULT	DESCRIPTION	
(3Bh) S/PDIF Transmitter Channel Bit Control 3	3:0	SRCNUM [3:0]	19:16	0000	Source Number. No definitions are attached to data. See S/PDIF specification for details.	
	5:4	CHNUM1[1:0]	23:20	00	Channel Number for Subframe 1	
					CHNUM1	Channel Status Bits[23:20]
					00	0000 = Do not use channel number
					01	0001 = Send to Left Channel
					10	0010 = Send to Right Channel
	11	0000 = Do not use channel number				
	7:6	CHNUM2[1:0]		00	Channel Number for Subframe 2	
					CHNUM2	Channel Status Bits[23:20]
					00	0000 = Do not use channel number
01					0001 = Send to Left Channel	
10					0010 = Send to Right Channel	
11	0000 = Do not use channel number					

Table 36 S/PDIF Tx Channel Bit Control 3

REGISTER ADDRESS	BIT	LABEL	CHANNEL STATUS BIT	DEFAULT	DESCRIPTION
(3Ch) S/PDIF Transmitter Channel Bit Control 4	3:0	FREQ[3:0]	27:24	0001	Sampling Frequency. See S/PDIF specification for details. 0001 = Sampling Frequency not indicated.
	5:4	CLKACU[1:0]	29:28	11	Clock Accuracy of Generated clock. 00 = Level II 01 = Level I 10 = Level III 11 = Interface frame rate not matched to sampling frequency.

Table 37 S/PDIF Tx Channel Bit Control 4

REGISTER ADDRESS	BIT	LABEL	CHANNEL STATUS BIT	DEFAULT	DESCRIPTION		
(3Dh) S/PDIF Transmitter Channel Bit Control 5	0	MAXPAIFRX_WL	32	1	Maximum Audio sample word length 0 = 20 bits 1 = 24 bits		
	3:1	TXPAIFRX_WL [2:0]	35:33	101	Audio Sample Word Length. 000 = Word Length Not Indicated		
					TXPAIFRX_WL	MAXPAIFRX_WL==1	MAXPAIFRX_WL==0
					001	20 bits	16 bits
					010	22 bits	18 bits
					100	23 bits	19 bits
					101	24 bits	20 bits
110	21 bits	17 bits					
All other combinations reserved							
7:4	ORGSAMP [3:0]	39:36	0000	Original Sampling Frequency. See S/PDIF specification for details. 0000 = original sampling frequency not indicated			

Table 38 S/PDIF Tx Channel Bit Control 5

S/PDIF RECEIVER

INPUT SELECTOR

The S/PDIF receiver has one dedicated input, SPIN. There are three other pins which can be configured as either S/PDIF inputs or general purpose outputs (GPOs). The four S/PDIF inputs go into a 4:1 mux, allowing one input to go to the S/PDIF receiver for decoding. The S/PDIF receiver can be powered down using the SPDIFRXD register bit.

REGISTER ADDRESS	BIT	LABEL	DEFAULT	DESCRIPTION
(40h) S/PDIF Receiver Input Selector	0	SPDINMODE	0	Selects the input circuit type for the S/PDIF input 0 = Normal CMOS input 1 = Comparator input. Compatible with 200mV AC coupled consumer S/PDIF input signals.
	5:4	RXINSEL[1:0]	00	S/PDIF Receiver input mux select. Note that the general purpose inputs must be configured using GPIOxOP to be either CMOS or comparator inputs if selected by RXINSEL. 00 = S/PDIF_IN1 01 = S/PDIF_IN2 (GPIO1) 10 = S/PDIF_IN3 (GPIO2) 11 = S/PDIF_IN4 (GPIO3)

Table 39 S/PDIF Rx Input Selection register

AUDIO DATA HANDLING

The S/PDIF receiver recovers the data and VUCP bits from each sub-frame. If the S/PDIF input data is in PCM format the data can be internally routed to the stereo data input of DAC1. The WM8777 can detect when the data is not in PCM format and will automatically mute the DAC. See *Non-Audio Detection* for more detail.

The received data can also be output over the Audio interfaces in any of the data formats supported. This can be done while simultaneously using DAC1 for playback. The received data may also be re-transmitted over SPDIFOP.

USER DATA

The WM8777 can output recovered user data received over the GPIO pins. See Table 48 for General Purpose Pin control.

CHANNEL STATUS DATA

The channel status bits are recovered from the incoming data stream and are used to control various functions of the device. The recovered MAXPAIFRX_WL and PAIFRX_WL bits are used to truncate the recovered 24-bit audio word to so that only the appropriate numbers of bits are used by the other interfaces (except the S/PDIF transmitter which always sees the full 24-bit recovered word).

Should the recovered DEEMPH Channel-bit be set, and DAC1 is used for playback, the de-emphasis filter is activated for that DAC.

It is assumed that the channel status is stereo and hence only channel 1 data is read. The channel status data is stored in 5 read-only registers which can be read back over the serial interface (see *Serial Interface Readback*). When the channel status data has been recovered and stored in registers, the CSUD (Channel Status UpDate) bit goes high to indicate that the registers are ready for readback. It will go low again when the first sub-frame of data from the next block is received. CSUD can be output to one of the GPIO pins.

The register descriptions for the channel status bits are given below. Note that the descriptions below refer to consumer mode. The WM8777 may give erroneous behaviour if professional format data is input.

REGISTER ADDRESS	BIT	LABEL	CHANNEL STATUS BIT	DESCRIPTION
(4Ch) S/PDIF Receiver Channel Status Register 1 (read-only)	0	CON/PRO	0	0 = Consumer Mode 1 = Professional Mode The WM8777 is a consumer mode device. Detection of professional mode may give erroneous behaviour.
	1	AUDIO_N	1	Recovered S/PDIF Channel status bit 1. 0 = Data word represents audio PCM samples. 1 = Data word does not represent audio PCM samples.
	2	CPY_N	2	0 = Copyright is asserted for this data. 1 = Copyright is not asserted for this data.
	3	PREEMPH	3	0 = Recovered S/PDIF data has no pre-emphasis. 1 = Recovered S/PDIF data has pre-emphasis.
	5:4	Reserved	5:4	Reserved for additional de-emphasis modes.

Table 40 S/PDIF Rx Channel Status Register 1

REGISTER ADDRESS	BIT	LABEL	CHANNEL STATUS BIT	DESCRIPTION
(4Dh) S/PDIF Receiver Channel Status Register 2 (read-only)	7:0	CATCODE [7:0]	15:8	Category Code. Refer to S/PDIF specification for details. 00h indicates "general" mode.

Table 41 S/PDIF Rx Channel Status Register 2

REGISTER ADDRESS	BIT	LABEL	CHANNEL STATUS BIT	DESCRIPTION
(4Eh) S/PDIF Receiver Channel Status Register 3 (read-only)	3:0	SRCNUM [3:0]	19:16	Indicates number of S/PDIF source.
	7:4	CHNUM1[3:0]	23:20	Channel number for channel 1. 0000 = Take no account of channel number (channel 1 defaults to left DAC) 0001 = channel 1 to left channel 0010 = channel 1 to right channel

Table 42 S/PDIF Rx Channel Status Register 3

REGISTER ADDRESS	BIT	LABEL	CHANNEL STATUS BIT	DESCRIPTION
(4Fh) S/PDIF Receiver Channel Status Register 4 (read-only)	3:0	FREQ[3:0]	27:24	Sampling Frequency. See S/PDIF specification for details. 0001 = Sampling Frequency not indicated.
	5:4	CLKACU[1:0]	29:28	Clock Accuracy of received clock. 00 = Level II 01 = Level I 10 = Level III 11 = Interface frame rate not matched to sampling frequency.

Table 43 S/PDIF Rx Channel Status Register 4

REGISTER ADDRESS	BIT	LABEL	CHANNEL STATUS BIT	DESCRIPTION		
(50h) S/PDIF Receiver Channel Status Register 5 (read-only)	0	MAXPAIFRX_WL	32	Maximum Audio sample word length 0 = 20 bits 1 = 24 bits		
	3:1	RXPAIFRX_WL [2:0]	35:33	Audio Sample Word Length. 000: Word Length Not Indicated		
				RXPAIFRX_WL	MAXPAIFRX_WL==1	MAXPAIFRX_WL==0
				001	20 bits	16 bits
				010	22 bits	18 bits
				100	23 bits	19 bits
				101	24 bits	20 bits
110	21 bits	17 bits				
	All other combinations are reserved and may give erroneous operation. Data will be truncated internally when these bits are set.					
7:4	ORGSAMP [3:0]	39:36	Original Sampling Frequency. See S/PDIF specification for details. 0000 = original sampling frequency not indicated			

Table 44 S/PDIF Rx Channel Status Register 5

ERROR HANDLING

Several kinds of error can be reported when decoding the incoming data. The error bits are written to a read-only register which can be read back by the user over the serial interface. Reading back this register will reset it.

REGISTER ADDRESS	BIT	LABEL	DEFAULT	DESCRIPTION
(4Bh) S/PDIF Receiver Error Register (read-only)	0	UNLOCK	0	PLL Unlock signal. 0 = PLL is locked to incoming S/PDIF stream. 1 = PLL is not locked to the incoming S/PDIF stream.
	1	VALIDITY	0	V bit from S/PDIF input stream. 0 = Data word is valid. 1 = Data word is not valid.
	2	PARITYERR	0	Even Parity check. 0 = No Parity errors detected. 1 = Parity error detected.
	3	BIP	0	Biphase coding of S/PDIF input stream. 0 = Biphase Coding is correct. 1 = Biphase Coding error detected.
	4	AUDIO_N	0	Received Channel status bit 1 has changed. 0 = Normal running. 1 = Change on AUDIO_N.
	5	PCM_N	0	PCM_N bit has changed 0 = Normal running. 1 = Change on PCM_N.
	6	CPY_N	0	Received Channel status bit 2 has changed. 0 = Normal running. 1 = Change on CPY_N.
	7	SPDIF_MODE	0	S/PDIF mode change. 0: Normal running 1: Change in S/PDIF frequency mode detected.

Table 45 S/PDIF Rx Error Status Register

When an error is detected the INT signal is set high. This is a logical OR of the error bits which can be output to a GPIO (GPIO1 by default). Error bits can be masked off by setting the mask register. If an error bit is masked off then that error will not be written to the error register and will not cause a change on INT.

UNLOCK, VALIDITY, PARITY and BIP generate an interrupt when they go from low to high. These bits are sticky, i.e. the interrupt will remain until the user reads back the register to clear it. AUDIO_N, PCM_N, CPY_N and SPDIF_MODE will generate an interrupt on any change in status. The user can then determine the status of these bits by reading back the S/PDIF status register.

REGISTER ADDRESS	BIT	LABEL	DEFAULT	DESCRIPTION
(51h) S/PDIF Status Register (read-only)	0	AUDIO_N		Received Channel status bit 1 0 = Data word represents audio PCM samples. 1 = Data word does not represent audio PCM samples.
	1	PCM_N		Detects non-audio data from a 96-bit sync code, as defined in IEC-61937. 0 = Sync code not detected. 1 = Sync code detected – received data is not audio PCM.
	2	CPY_N		Recovered S/PDIF Channel status bit 2. 0 = Copyright is asserted for this data. 1 = Copyright is not asserted for this data. Note this signal is inverted and will cause an interrupt on logic 0.
	4:3	SPDIF_MODE		S/PDIF frequency mode. 00: Mode not supported 01: 88-96KHz 10: 44-48KHz 11: 32KHz

Table 46 S/PDIF Rx Status Register

Should the incoming S/PDIF sub-frame contain a PARITY error or a BIP error, it is assumed the sub-frame has become corrupted. These errors would normally be flagged, but if the error bits have been masked, the WM8777 will instead overwrite the recovered frame (i.e. **both** sub-frames) with either all-zeros or the last data sample (depending on how FILLMODE has been set). When the flags are unmasked and an error is detected, the data is allowed to pass, albeit still corrupted.

Similarly, if VALIDITY is detected as 1, it is assumed the data within the S/PDIF frame is invalid. If VALIDITY is masked, then data is overwritten depending on FILLMODE, else VALIDITY is flagged and the (invalid) data is allowed to pass. (Note1: ALWAYSVALID must be set to 0, else the recovered VALIDITY bit will be ignored). (Note 2: For the S/PDIF Receiver to S/PDIF transmitter path, only masked VALIDITY errors will cause data to be overwritten – PARITY and BIP errors have no effect).

REGISTER ADDRESS	BIT	LABEL	DEFAULT	DESCRIPTION
(49h) S/PDIF Receiver Error Mask	7:0	MASK[7:0]	0000000	When a lag is masked, it does not update the Error Register or contribute to the interrupt pulse. 0 = unmask, 1 = mask. MASK[0] = mask control for UNLOCK MASK[1] = mask control for VALIDITY MASK[2] = mask control for PARITYERR MASK[3] = mask control for BIP MASK[4] = mask control for AUDIO_N MASK[5] = mask control for PCM_N MASK[6] = mask control for CPY_N MASK[7] = mask control for SPDIF_MODE
(40h) S/PDIF Receiver Input Selector	6	FILLMODE	0	Determines what SPDIF_RX should do if the validity bit indicates invalid data: 0 = Data from SPDIF_RX remains static at last valid sample. 1 = Data from SPDIF_RX is output as all zeros.
	7	ALWAYSVALID	0	Used to override the recovered validity bit. 0 = Use validity bit. 1 = Ignore validity bit.

Table 47 S/PDIF Rx Error Mask Register

The circuit for dealing with UNLOCK, VALIDITY, PARITY and BIP errors is shown in Figure 26.

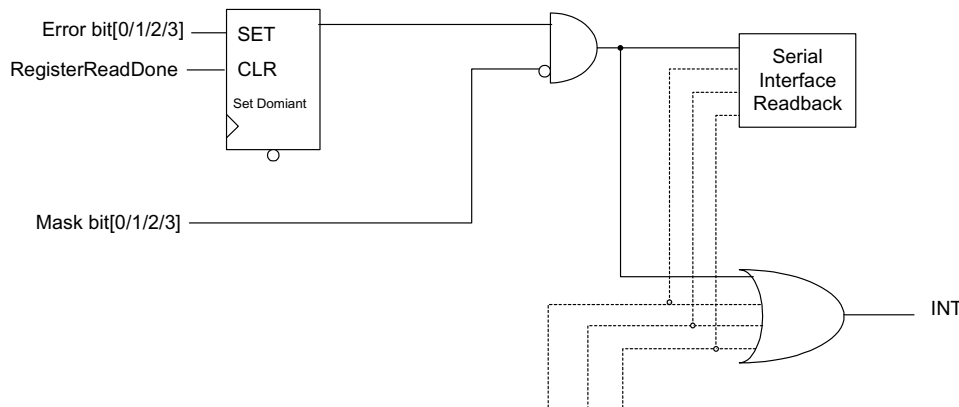

Figure 26 S/PDIF Error Handling Circuit for UNLOCK, VALIDITY, PARITY and BIP Errors

NON-AUDIO DETECTION

Non-Audio data is indicated by the AUDIO_N and PCM_N bits. AUDIO_N is recovered from the Channel Status block. PCM_N is set on detection of the 96-bit IEC-61937 non-audio data sync code, embedded in the data section of the S/PDIF frame. When either the AUDIO_N or PCM_N bits are set in the error register, and DAC1 is being used for playback, the DAC will be muted automatically using the softmute feature. As described above, any change on AUDIO_N or PCM_N will cause an interrupt to be generated. If the MASK register bit for AUDIO_N or PCM_N is set, then that signal will not generate an interrupt but will still mute the DAC.

If non-audio data is detected and the DAC has been muted, the user must ensure that audio data is being input, then clear the error register. The mute on the DAC will be removed when the WM8777 detects that audio data is being received.

GENERAL PURPOSE INPUT AND OUTPUT (GPIO) PINS

The WM8777 has four pins which can be additionally configured as GPIOs, using the registers shown in Table 48. The GPIO pins can be used to output control and status data decoded by the S/PDIF receiver

REGISTER ADDRESS	BIT	LABEL	DEFAULT	DESCRIPTION
(47h) GPIO Control 1	3:0	GPIO1OP[3:0]	0000	0000 = INT
	7:4	GPIO2OP[3:0]	0001	0001 = V - Validity 0010 = U - User Data bit
(48h) GPIO Control 2	3:0	GPIO3OP[3:0]	0010	0011 = C - Channel Status Data
	7:4	GPOMODEOP [3:0]	1010	0100 = P - Parity bit 0101 = Non-audio (AUDIO_N PCM_N) 0110 = UNLOCK 0111 = CSUD (Channel Status Registers Updated) 1000 = Zero Flag 1 output 1001 = Zero Flag 2 output 1010 = GPIOx set as S/PDIF input (standard CMOS input buffer). Not valid for GPOMODE. 1011 = GPIOx set as S/PDIF input ('comparator' input for AC coupled consumer S/PDIF signals). Not valid for GPOMODE. 1100 = Sub Frame clock (1 = sub-frame1, 0 = sub-frame2) 1101 = Start of Block signal

Table 48 GPIO Control Registers

DAC CONTROL REGISTERS

DAC INPUT CONTROL

The primary audio interface has a separate input pin for each stereo DAC. Any input pin can be routed to any DAC using the DACxSEL register bits.

REGISTER ADDRESS	BIT	LABEL	DEFAULT	DESCRIPTION
(38h) DAC Digital Input Selector	1:0	DAC1SEL [1:0]	00	DAC digital input select. 00 = DAC takes data from PDATAIP1 01 = DAC takes data from PDATAIP2 10 = DAC takes data from PDATAIP3 11 = DAC takes data from PDATAIP4
	3:2	DAC2SEL [1:0]	01	
	5:4	DAC3SEL [1:0]	10	
	7:6	DAC4SEL [1:0]	11	

Table 49 DAC Input Select Register

MUTE MODES

The WM8777 has individual mutes for each of the four DAC channels. Setting MUTE for a channel will apply a 'soft' mute to the input of the digital filters of the channel muted. DMUTE[0] mutes DAC channel 1, DMUTE[1] mutes DAC channel 2, DMUTE[2] mutes DAC channel 3 and DMUTE[3] mutes DAC channel 4. Setting the MUTEALL register bit will apply a 'soft' mute to the input of all the DAC digital filters

REGISTER ADDRESS	BIT	LABEL	DEFAULT	DESCRIPTION
(16h) Mute Control	3:0	DMUTE[3:0]	0000	DAC channel soft mute enables: DMUTE[0] = 1, enable softmute on DAC1. DMUTE[1] = 1, enable softmute on DAC2. DMUTE[2] = 1, enable softmute on DAC3. DMUTE[3] = 1, enable softmute on DAC4.
	4	MUTEALL	0	DAC channel master soft mute. Mutes all DAC channels: 0 = disable softmute on all DACs. 1 = enable softmute on all DACs.

Table 50 Mute Registers

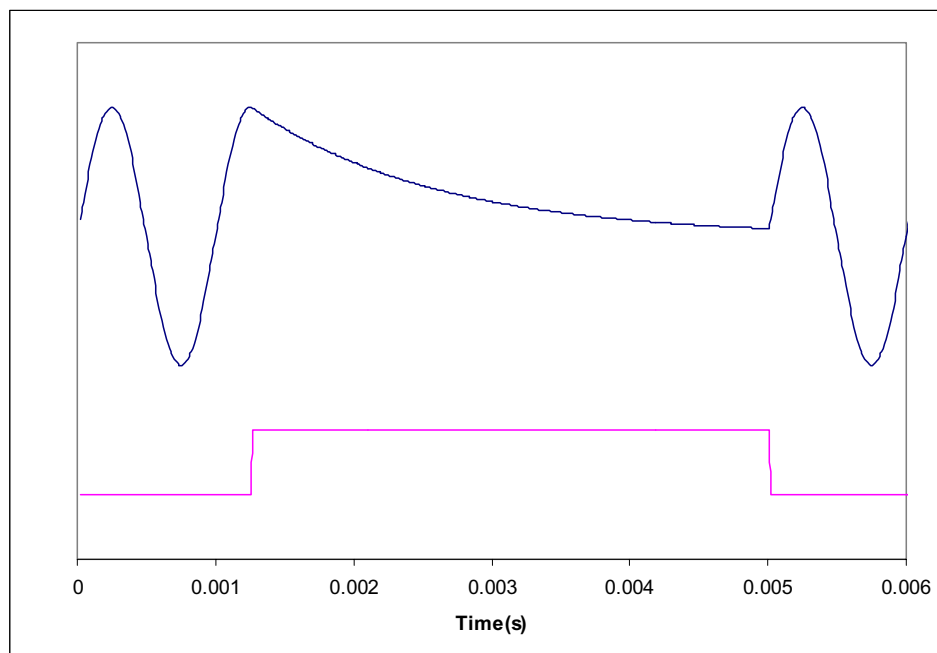

Figure 27 Application and Release of Soft Mute

Figure 27 shows the application and release of MUTE whilst a full amplitude sinusoid is being played at 48kHz sampling rate. When MUTE (lower trace) is asserted, the output (upper trace) begins to decay exponentially from the DC level of the last input sample. The output will decay towards V_{MID} with a time constant of approximately 64 input samples. If MUTE is applied to all channels for 1024 or more input samples the DAC will be muted if IZD is set. When MUTE is de-asserted, the output will restart immediately from the current input sample.

Note that all other means of muting the DAC channels: setting the PL[3:0] bits to 0, setting the PDWN bit or setting attenuation to 0 will cause much more abrupt muting of the output.

The Record outputs may be enabled by setting RECEN, where RECEN enables the REC1L and REC1R outputs.

REGISTER ADDRESS	BIT	LABEL	DEFAULT	DESCRIPTION
(16h) Mute Control	6:5	RECLEN	00	RECL Output Enable 00 = REC output muted 01 = REC output ADCL 10 = REC output DAC1L
	8:7	RECREN	00	RECR Output Enable 00 = REC output muted 01 = REC output ADCR 10 = REC output DAC1R

Table 51 REC Enable Registers

ZERO FLAG OUTPUT

The WM8777 has a zero detect circuit for each DAC channel which detects when 1024 consecutive zero samples have been input. Two zero flag outputs (ZFLAG1 and ZFLAG2) may be output through the GPIO pins which may then be used to control external muting circuits. A '1' on ZFLAG1 or ZFLAG2 indicates a zero detect. The zero detect may also be used to automatically enable the DAC mute by setting IZD. The zero flag output may be disabled by setting DZFM to 0000. The zero flag signal for a DAC channel will only be a '1' if that channel is disabled as an input to the output summing stage.

REGISTER ADDRESS	BIT	LABEL	DEFAULT	DESCRIPTION
(17h) DAC Control	7:4	DZFM[3:0]	0000	Selects the output for ZFLAG1 and ZFLAG2 pins (see Table 53). 1 = indicates 1024 consecutive zero input samples on the channels selected 0 = indicates at least one of selected channels has non zero sample in last 1024 inputs

Table 52 DZFM Register

DZFM[3:0]	ZFLAG1	ZFLAG2
0000	Zero flag disabled	Zero flag disabled
0001	All channels zero	All channels zero
0010	Left channels zero	Right channels zero
0011	Channel 1 zero	Channels 2-4 zero
0100	Channel 1 zero	Channel 2 zero
0101	Channel 1 zero	Channel 3 zero
0110	Channel 1 zero	Channel 4 zero
0111	Channel 2 zero	Channel 3 zero
1000	Channel 2 zero	Channel 4 zero
1001	Channel 3 zero	Channel 4 zero
1010	Channels 1-3 zero	Channel 4 zero
1011	Channel 1 zero	Channels 2 and 3 zero
1100	Channel 1 left zero	Channel 1 right zero
1101	Channel 2 left zero	Channel 2 right zero
1110	Channel 3 left zero	Channel 3 right zero
1111	Channel 4 left zero	Channel 4 right zero

Table 53 Zero Flag Output Select

INFINITE ZERO DETECT

Setting the IZD register bit will enable the internal infinite zero detect function:

REGISTER ADDRESS	BIT	LABEL	DEFAULT	DESCRIPTION
(15h) DAC Attenuation Control	2	IZD	0	Infinite zero detection circuit control and automute control 0 = Infinite zero detect automute disabled 1 = Infinite zero detect automute enabled

Table 54 IZD Register

With IZD enabled, applying 1024 consecutive zero input samples each stereo channel will cause that stereo channels outputs to be muted. Mute will be removed as soon as any channel receives a non-zero input.

DE-EMPHASIS MODE

A digital De-emphasis filter may be applied to each DAC channel. The De-emphasis filter for each stereo channel is enabled under the control of DEEMP[3:0]. DEEMP[0] enables the de-emphasis filter for channel 1, DEEMP[1] enables the de-emphasis filter for channel 2, DEEMP[2] enables the de-emphasis filter for channel 3 and DEEMP[3] enables the de-emphasis filter for channel 4.

REGISTER ADDRESS	BIT	LABEL	DEFAULT	DESCRIPTION
(17h) DAC Control	3:0	DEEMP[3:0]	0000	De-emphasis mode select: DEEMPH[0] = 1, enable De-emphasis on DAC1. DEEMPH[1] = 1, enable De-emphasis on DAC2. DEEMPH[2] = 1, enable De-emphasis on DAC3. DEEMPH[3] = 1, enable De-emphasis on DAC4.

Table 55 De-emphasis Register

Refer to Figure 39, Figure 40, Figure 41, Figure 42, Figure 43 and Figure 44 for details of the De-Emphasis modes at different sample rates.

DAC OUTPUT CONTROL

The DAC output control word determines how the left and right inputs to the audio Interface are applied to the left and right DACs:

REGISTER ADDRESS	BIT	LABEL	DEFAULT	DESCRIPTION		
(15h) DAC Attenuation Control	8:5	PL[3:0]	1001	PL[3:0]	Left Output	Right Output
				0000	Mute	Mute
				0001	Left	Mute
				0010	Right	Mute
				0011	(L+R)/2	Mute
				0100	Mute	Left
				0101	Left	Left
				0110	Right	Left
				0111	(L+R)/2	Left
				1000	Mute	Right
				1001	Left	Right
				1010	Right	Right
				1011	(L+R)/2	Right
				1100	Mute	(L+R)/2
				1101	Left	(L+R)/2
				1110	Right	(L+R)/2
				1111	(L+R)/2	(L+R)/2

Table 56 DAC Attenuation Register (PL)

DAC OVERSAMPLING RATE SELECT

Control bit DACOSR allow the user to select the DAC internal signal processing oversampling rate. Operation is described in Table 18 and Table 19.

REGISTER ADDRESS	BIT	LABEL	DEFAULT	DESCRIPTION
(19h) DAC Oversampling Rate Select	3	DACOSR	0	DAC oversampling rate select 0: 128x oversampling 1: 64x oversampling

Table 57 DAC Oversampling Rate

ATTENUATOR CONTROL MODE

Setting the ATC register bit causes the left channel attenuation settings to be applied to both left and right channel DACs from the next audio input sample. No update to the attenuation registers is required for ATC to take effect. When the ATC register bit is unset the right channel gain is applied from the new audio input sample.

REGISTER ADDRESS	BIT	LABEL	DEFAULT	DESCRIPTION
(15h) DAC Attenuation Control	1	DACATC	0	Attenuator Control 0 = All DACs use attenuations as programmed. 1 = Right channel DACs use corresponding left DAC attenuations

Table 58 DAC Attenuation Register (DACATC)

ANALOGUE VOLUME CONTROL

The DAC volume may be adjusted independently in both the analogue and digital domain using separate volume control registers.

REGISTER ADDRESS	BIT	LABEL	DEFAULT	DESCRIPTION
(00h) Analogue Attenuation FRONTL	6:0	FRONTLA [6:0]	1101011 (0dB)	Analogue Attenuation control for FRONTL in 1dB steps. See Table 60.
	7	FRONTLZCEN	0	FRONTL zero cross detect enable 0 = zero cross disabled 1 = zero cross enabled
	8	UPDATE	Not latched	Controls simultaneous update of all Analogue Attenuation Latches 0 = Store FRONTL in intermediate latch (no change to output) 1 = Store FRONTL and update attenuation on all channels.
(01h) Analogue Attenuation FRONTR	6:0	FRONTRA [6:0]	1101011 (0dB)	Analogue Attenuation control for FRONTR in 1dB steps. See Table 60.
	7	FRONTRZCEN	0	FRONTR zero cross detect enable 0 = zero cross disabled 1 = zero cross enabled
	8	UPDATE	Not latched	Controls simultaneous update of all Analogue Attenuation Latches 0 = Store FRONTR in intermediate latch (no change to output) 1 = Store FRONTR and update attenuation on all channels.
(02h) Analogue Attenuation CNTR	6:0	CNTRA [6:0]	1101011 (0dB)	Analogue Attenuation control for CNTR in 1dB steps. See Table 60.
	7	CNTRZCEN	0	CNTR zero cross detect enable 0 = zero cross disabled 1 = zero cross enabled
	8	UPDATE	Not latched	Controls simultaneous update of all Analogue Attenuation Latches 0 = Store CNTR in intermediate latch (no change to output) 1 = Store CNTR and update attenuation on all channels.
(03h) Analogue Attenuation LFE	6:0	LFEA [6:0]	1101011 (0dB)	Analogue Attenuation control for LFE in 1dB steps. See Table 60.
	7	LFEZCEN	0	LFE zero cross detect enable 0 = zero cross disabled 1 = zero cross enabled
	8	UPDATE	Not latched	Controls simultaneous update of all Analogue Attenuation Latches 0 = Store LFE in intermediate latch (no change to output) 1 = Store LFE and update attenuation on all channels.

REGISTER ADDRESS	BIT	LABEL	DEFAULT	DESCRIPTION
(04h) Analogue Attenuation SURL	6:0	SURLA [6:0]	1101011 (0dB)	Analogue Attenuation control for SURL in 1dB steps. See Table 60.
	7	SURLZCEN	0	SURL zero cross detect enable 0 = zero cross disabled 1 = zero cross enabled
	8	UPDATE	Not latched	Controls simultaneous update of all Analogue Attenuation Latches 0 = Store SURL in intermediate latch (no change to output) 1 = Store SURL and update attenuation on all channels.
(05h) Analogue Attenuation SURR	6:0	SURRA [6:0]	1101011 (0dB)	Analogue Attenuation control for SUR Right in 1dB steps.
	7	SURRZCEN	0	SURR zero cross detect enable 0 = zero cross disabled 1 = zero cross enabled
	8	UPDATE	Not latched	Controls simultaneous update of all Analogue Attenuation Latches 0 = Store SURR in intermediate latch (no change to output) 1 = Store SURR and update attenuation on all channels.
(06h) Analogue Attenuation AUXL	6:0	AUXLA[6:0]	1101011 (0dB)	Analogue Attenuation control for AUXL in 1dB steps. See Table 60.
	7	AUXLZCEN	0	AUXL zero cross detect enable 0 = zero cross disabled 1 = zero cross enabled
	8	UPDATE	Not latched	Controls simultaneous update of all Analogue Attenuation Latches 0 = Store AUXL in intermediate latch (no change to output) 1 = Store AUXL and update attenuation on all channels.
(07h) Analogue Attenuation AUXR	6:0	AUXRA[6:0]	1101011 (0dB)	Analogue Attenuation control for AUXR in 1dB steps. See Table 60.
	7	AUXRZCEN	0	AUXR zero cross detect enable 0 = zero cross disabled 1 = zero cross enabled
	8	UPDATE	Not latched	Controls simultaneous update of all Analogue Attenuation Latches 0 = Store AUXR in intermediate latch (no change to output) 1 = Store AUXR and update attenuation on all channels.
(08h) Analogue Attenuation HPHONEL	6:0	HPLA[6:0]	1101011 (0dB)	Analogue Attenuation control for HPHONEL in 1dB steps. See Table 60.
	7	HPLZCEN	0	HPHONEL zero cross detect enable 0 = zero cross disabled 1 = zero cross enabled
	8	UPDATE	Not latched	Controls simultaneous update of all Analogue Attenuation Latches 0 = Store HPHONEL in intermediate latch (no change to output) 1 = Store HPHONEL and update attenuation on all channels.
(09h) Analogue Attenuation HPHONER	6:0	HPRA[6:0]	1101011 (0dB)	Analogue Attenuation control for HPHONER in 1dB steps. See Table 60.
	7	HPRZCEN	0	HPHONER zero cross detect enable 0 = zero cross disabled 1 = zero cross enabled
	8	UPDATE	Not latched	Controls simultaneous update of all Analogue Attenuation Latches 0 = Store HPHONER in intermediate latch (no change to output) 1 = Store HPHONER and update attenuation on all channels.

REGISTER ADDRESS	BIT	LABEL	DEFAULT	DESCRIPTION
(0Ah) Analogue Attenuation Master (all channels)	6:0	MASTA[6:0]	1101011 (0dB)	Analogue Attenuation control for all DAC gains in 1dB steps. See Table 60.
	7	MZCEN	0	Master zero cross detect enable 0 = zero cross disabled 1 = zero cross enabled
	8	UPDATE	Not latched	Controls simultaneous update of all Analogue Attenuation Latches 0 = Store gains in intermediate latch (no change to output) 1 = Store gains and update attenuation on all channels.

Table 59 Analogue Attenuation Registers

Each analogue output channel volume can be controlled digitally in an analogue volume stage after the DAC. Attenuation is 0dB by default but can be set between +20dB and -100dB in 1dB steps using the 7 Attenuation control words. All attenuation registers are double latched allowing new values to be pre-latched to several channels before being updated synchronously. Setting the UPDATE bit on any attenuation write will cause all pre-latched values to be immediately applied to the DAC channels. A master attenuation register is also included, allowing all volume levels to be set to the same value in a single write.

Note: The UPDATE bit is not latched. If UPDATE=0, the Attenuation value will be written to the pre-latch but not applied to the relevant output. If UPDATE=1, all pre-latched values will be applied from the next input sample. Writing to MASTA[6:0] overwrites any values previously sent to FRONTL[6:0], CNTR[6:0], SURL[6:0], AUXL[6:0], FRONTR[6:0], LFE[6:0], SURR[6:0], AUXR[6:0].

Register bits FRONTL and FRONTR control the left and right channel attenuation of the Front channels. Register bits CNTR and LFE control the left and right channel attenuation of CNTR and LFE respectively. Register bits SURL and SURR control the left and right channel attenuation of surround channels. Register bits AUXL and AUXR control the left and right channel attenuation of the auxiliary channel. Register bits MASTA can be used to control attenuation of all channels.

Table 60 shows how the attenuation levels are selected from the 7-bit words.

L/RAX[6:0]	ATTENUATION LEVEL
00(hex)	-∞dB (mute)
:	:
06(hex)	-∞dB (mute)
07(hex)	-100dB
:	:
6B(hex)	0dB (default)
7D(hex)	+18dB
7E(hex)	+19dB
7F(hex)	+20dB

Table 60 Analogue Volume Control Attenuation Levels

In addition a zero cross detect circuit is provided for each analogue output volume under the control of bit 7 (xZCEN) in each Analogue attenuation register. When ZCEN is set the attenuation values are only updated when the input signal to the gain stage is close to the analogue ground level. This minimises audible clicks and 'zipper' noise as the gain values change. A timeout clock is also provided which will generate an update after a minimum of 131072 master clocks (~10.5ms with a master clock of 12.288MHz). The timeout clock may be disabled by setting TOCDAC.

REGISTER ADDRESS	BIT	LABEL	DEFAULT	DESCRIPTION
(15h) Timeout Clock Disable	4	TOCDAC	0	DAC Analogue Zero cross detect timeout disable 0 = Timeout enabled 1 = Timeout disabled

Table 61 Timeout Clock Disable Register

DAC DIGITAL VOLUME CONTROL

The DAC volume may also be adjusted in the digital domain using independent digital attenuation control registers

REGISTER ADDRESS	BIT	LABEL	DEFAULT	DESCRIPTION
(0Bh) Digital Attenuation DACL1	7:0	LDA1[7:0]	11111111 (0dB)	Digital Attenuation control for DAC1 Left Channel (LSUMOP) in 0.5dB steps. See Table 63
	8	UPDATE	Not latched	Controls simultaneous update of all Attenuation Latches 0 = Store LDA1 in intermediate latch (no change to output) 1 = Store LDA1 and update attenuation on all channels
(0Ch) Digital Attenuation DACR1	7:0	RDA1[6:0]	11111111 (0dB)	Digital Attenuation control for DAC1 Right Channel (RSUMOP) in 0.5dB steps. See Table 63
	8	UPDATE	Not latched	Controls simultaneous update of all Attenuation Latches 0 = Store RDA1 in intermediate latch (no change to output) 1 = Store RDA1 and update attenuation on all channels.
(0Dh) Digital Attenuation DACL2	7:0	LDA2[7:0]	11111111 (0dB)	Digital Attenuation control for DAC2 Left Channel (CNTSOP) in 0.5dB steps. See Table 63
	8	UPDATE	Not latched	Controls simultaneous update of all Attenuation Latches 0 = Store LDA2 in intermediate latch (no change to output) 1 = Store LDA2 and update attenuation on all channels.
(0Eh) Digital Attenuation DACR2	7:0	RDA2[7:0]	11111111 (0dB)	Digital Attenuation control for DAC2 Right Channel (LFESOP) in 0.5dB steps. See Table 63
	8	UPDATE	Not latched	Controls simultaneous update of all Attenuation Latches 0 = Store RDA2 in intermediate latch (no change to output) 1 = Store RDA2 and update attenuation on all channels.
(0Fh) Digital Attenuation DACL3	7:0	LDA3[7:0]	11111111 (0dB)	Digital Attenuation control for DAC3 Left Channel (LSURSOP) in 0.5dB steps. See Table 63
	8	UPDATE	Not latched	Controls simultaneous update of all Attenuation Latches 0 = Store LDA3 in intermediate latch (no change to output) 1 = Store LDA3 and update attenuation on all channels.
(10h) Digital Attenuation DACR3	7:0	RDA3[7:0]	11111111 (0dB)	Digital Attenuation control for DAC3 Right Channel (RSURSOP) in 0.5dB steps. See Table 63
	8	UPDATE	Not latched	Controls simultaneous update of all Attenuation Latches 0 = Store RDA3 in intermediate latch (no change to output) 1 = Store RDA3 and update attenuation on all channels.
(11h) Digital Attenuation DACL4	7:0	LDA4[7:0]	11111111 (0dB)	Digital Attenuation control for DAC4 Left Channel (LAUXSOP) in 0.5dB steps. See Table 63
	8	UPDATE	Not latched	Controls simultaneous update of all Attenuation Latches 0 = Store LDA4 in intermediate latch (no change to output) 1 = Store LDA4 and update attenuation on all channels.
(12h) Digital Attenuation DACR4	7:0	RDA4[7:0]	11111111 (0dB)	Digital Attenuation control for DAC4 Right Channel (RAUXSOP) in 0.5dB steps. See Table 63
	8	UPDATE	Not latched	Controls simultaneous update of all Attenuation Latches 0 = Store RDA4 in intermediate latch (no change to output) 1 = Store RDA4 and update attenuation on all channels.
(13h) Digital Attenuation Master (all channels)	7:0	MASTDA[7:0]	11111111 (0dB)	Digital Attenuation control for all DAC channels in 0.5dB steps. See Table 63
	8	UPDATE	Not latched	Controls simultaneous update of all Attenuation Latches 0 = Store gain in intermediate latch (no change to output) 1 = Store gain and update attenuation on all channels.

Table 62 Digital Attenuation Registers

L/RDAX[7:0]	ATTENUATION LEVEL
00(hex)	-∞ dB (mute)
01(hex)	-127.5dB
:	:
:	:
:	:
FE(hex)	-0.5dB
FF(hex)	0dB

Table 63 Digital Volume Control Attenuation Levels

The Digital volume control also incorporates a zero cross detect circuit which detects a transition through the zero point before updating the digital volume control with the new volume. This is enabled by control bit DZCEN.

REGISTER ADDRESS	BIT	LABEL	DEFAULT	DESCRIPTION
(15h) DAC Attenuation Control	0	DZCEN	0	DAC Digital Volume Zero Cross Enable: 0 = Zero Cross detect disabled 1 = Zero Cross detect enabled

Table 64 Digital Zero Cross Register

DAC OUTPUT PHASE

The DAC Phase control word determines whether the output of each DAC is non-inverted or inverted

REGISTER ADDRESS	BIT	LABEL	DEFAULT	DESCRIPTION
(14h) DAC Output Phase	7:0	PHASE [7:0]	00000000	Controls phase of DAC outputs PHASE[0] = 1 inverts phase of DAC1L output PHASE[1] = 1 inverts phase of DAC1R output PHASE[2] = 1 inverts phase of DAC2L output PHASE[3] = 1 inverts phase of DAC2R output PHASE[4] = 1 inverts phase of DAC3L output PHASE[5] = 1 inverts phase of DAC3R output PHASE[6] = 1 inverts phase of DAC4L output PHASE[7] = 1 inverts phase of DAC4R output

Table 65 DAC Output Phase Register

OUTPUT SELECT AND ENABLE CONTROL

Register bits MX1[2:0] to MX4[2:0] control the output select. The output select block consists of a summing stage and an input select switch for each input allowing each signal to be output individually or summed with other signals and output on each analogue output. The default for all outputs is DAC playback only. VOUT1/2/3 may be selected to output DAC playback, AUX, analogue bypass or a sum of these using the output select controls MX1/2/3[2:0]. VOUT4 may be selected to output DAC playback, analogue bypass or a sum of these signals using MX4[1:0]. It is recommended that bypass is not selected for output on more than two stereo channels simultaneously to avoid overloading the input buffer, resulting in a decrease in performance.

The output mixers and PGAs can be powered down under control of OUTPD1/2/3/4. Each stereo channel may be powered down separately. Setting OUTPD1/2/3/4 will power off the mixer and PGA and switch the analogue outputs VOUTL/R to VMIDDAC to maintain a dc level on the output.

REGISTER ADDRESS	BIT	LABEL	DEFAULT	DESCRIPTION
(32h) Output Mux and Powerdown Control 1	2:0	MX1[2:0]	001 (DAC playback)	VOUT1 Output select (see Figure 28)
	5:3	MX2[2:0]	001 (DAC playback)	VOUT2 Output select (see Figure 28)
(33h) Output Mux and Powerdown Control 2	2:0	MX3[2:0]	001 (DAC playback)	VOUT3 Output select (see Figure 28)
	4:3	MX4[1:0]	01 (DAC playback)	VOUT4 Output select (see Figure 29)

Table 66 Output Mux Register

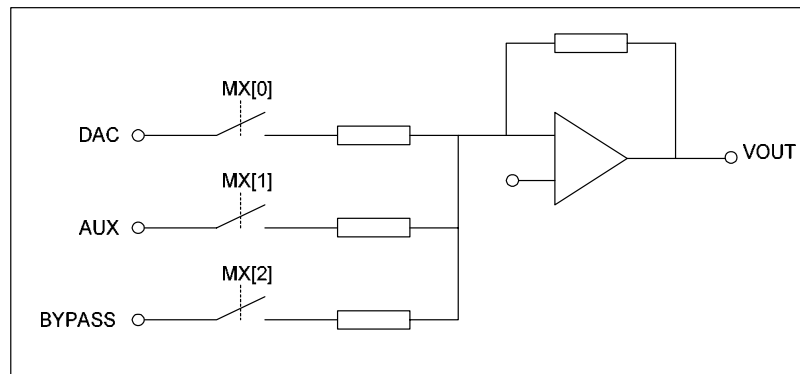

Figure 28 MX1/2/3[2:0] Output Select

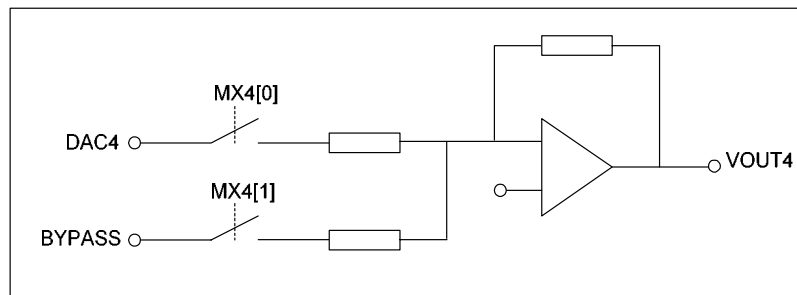

Figure 29 MX4[1:0] Output Select

ADC CONTROL REGISTERS

ADC GAIN CONTROL

The ADC has an analogue input PGA and digital gain control for each stereo channel. Both the analogue and digital gains are adjusted by the same register, LAG for the left and RAG for the right. The analogue PGA has a range of +24dB to -21dB in 0.5dB steps. The digital gain control allows further attenuation (after the ADC) from -21.5dB to -103dB in 0.5dB steps. Table 68 shows how the register maps the analogue and digital gains.

REGISTER ADDRESS	BIT	LABEL	DEFAULT	DESCRIPTION
(2Eh) Attenuation ADC Left	7:0	LAG[7:0]	11001111 (0dB)	Attenuation control for left channel ADC gain in 0.5dB steps. See Table 68
	8	ZCLEN	0	Zero Cross enable for left channel ADC 0 = Disable Zero Cross 1 = Enable Zero Cross
(2Fh) Attenuation ADC Right	7:0	RAG[7:0]	11001111 (0dB)	Attenuation control for right channel ADC gain in 0.5dB steps. See Table 68
	8	ZCREN	0	Zero Cross enable for right channel ADC 0 = Disable Zero Cross 1 = Enable Zero Cross
(30h) Attenuation Control	0	MUTEL	0	Left Channel mute control 0 = Channel not muted 1 = Channel muted
	1	MUTER	0	Right Channel mute control 0 = Channel not muted 1 = Channel muted
	2	ADCATC	0	Attenuator Control 0 = ADC use attenuations as programmed. 1 = Right channel ADC use corresponding left ADC attenuations
	3	TOADC	0	Time out clock enable/disable 0 = Time out clock enabled. 1 = Time out clock disabled.

Table 67 ADC Attenuation and Mute Registers

LAG/RAG[7:0]	ATTENUATION LEVEL (AT OUTPUT)	ANALOGUE PGA	DIGITAL ATTENUATION
00(hex)	-∞ dB (mute)	-21dB	Digital mute
01(hex)	-103dB	-21dB	-82dB
:	:	:	:
A4(hex)	-21.5dB	-21dB	-0.5dB
A5(hex)	-21dB	-21dB	0dB
:	:	:	:
CF(hex)	0dB	0dB	0dB
:	:	:	:
FE(hex)	+23.5dB	+23.5dB	0dB
FF(hex)	+24dB	+24dB	0dB

Table 68 Analogue and Digital Gain Mapping for ADC

In addition a zero cross detect circuit is provided for the output PGA volume under the control of bit 7 (ZCEN) in the each attenuation register. When ZCEN is set the attenuation values are only updated when the input signal to the gain stage is close to the analogue ground level. This minimises audible clicks and 'zipper' noise as the gain values change. A timeout clock is also provided which will generate an update after a minimum of 131072 master clocks (= ~10.5ms with a master clock of 12.288MHz). The timeout clock may be disabled by setting TOADC.

Each ADC channel also has an individual mute control bit, which mutes the input to the ADC. The ADCATC control bit allows the user to write the same attenuation value (LAG) to both left and right volume control registers, saving on software writes. When setting the ADCATC function it is up to the user to write a new gain value to take effect on both channels. When unsetting the ADCATC function it is up to the user to write a new gain to both the left and right channel gains. The ATC function has no effect when the ALC is enabled. The ADC volume and mute also applies to the bypass signal path.

ADC OVERSAMPLING RATE SELECT

The signal processing for the WM8777 typically operates at an oversampling rate of 128fs for the ADC (ADCOSR=0). The exception to this is for operation with a 128/192fs system clock, where the oversampling rate is 64fs (ADCOSR=1). For the ADC operation at 96kHz in 256fs or 384fs mode it is recommended that the user set the ADCOSR bit. This changes the ADC signal processing oversample rate from 128fs to 64fs. For the ADC operation at 192KHz in 128fs or 192fs mode it is recommended that the user set the ADCOSR bit. This changes the ADC signal processing oversample rate from 64fs to 32fs.

The ADC digital filters contain a digital highpass filter. This defaults to enabled and can be disabled using software control bit ADCHPD.

If the DAC and ADC are using the same MCLK source, and they are in compatible fs modes the ADC and DAC will try to lock their respective clock generators together. This reduces the digital noise on chip and helps the performance of the device. By default this is enabled, but can be disabled by setting SYNC to 1.

REGISTER ADDRESS	BIT	LABEL	DEFAULT	DESCRIPTION
(1Bh) ADC Interface Control	6	ADCHPD	0	ADC Highpass Filter Disable: 0 = Highpass Filter enabled 1 = Highpass Filter disabled
	7	ADCOSR	0	ADC oversample rate select 0 = 128x oversampling 1 = 64x oversampling
	8	SYNC	0	Sync ADC and DAC together. 0 = Enable SYNC function 1 = Disable Sync function

Table 69 ADC Functions Register

ADC INPUT MUX

REGISTER ADDRESS	BIT	LABEL	DEFAULT	DESCRIPTION
(31h) ADC Mux and Powerdown Control	5:0	AIN[5:0]	00000	ADC input mixer control bits (see Table 71)

Table 70 ADC Input Mux Register

Register bits AIN[5:0] control the left and right channel inputs into the stereo ADC. The default is AIN1. However if the analogue input buffer is powered down, by setting AINPD, then all 12-channel mux inputs are switched to buffered VMIDADC.

AIN[5:0]	ADC INPUT
00000	MUTE
00001	AIN1
00010	AIN2
00011	AIN1 + AIN2
00100	AIN3
00101	AIN3 + AIN1
.....
11111	AIN6 + AIN5 + AIN4 + AIN3 + AIN2 + AIN1

Table 71 ADC Input Mux Control

LIMITER / AUTOMATIC LEVEL CONTROL (ALC)

The WM8777 has an automatic PGA gain control circuit, which can function as a peak limiter or as an automatic level control (ALC). In peak limiter mode, a digital peak detector detects when the input signal goes above a predefined level and will ramp the PGA gain down to prevent the signal becoming too large for the input range of the ADC. When the signal returns to a level below the threshold, the PGA gain is slowly returned to its starting level. The peak limiter cannot increase the PGA gain above its static level.

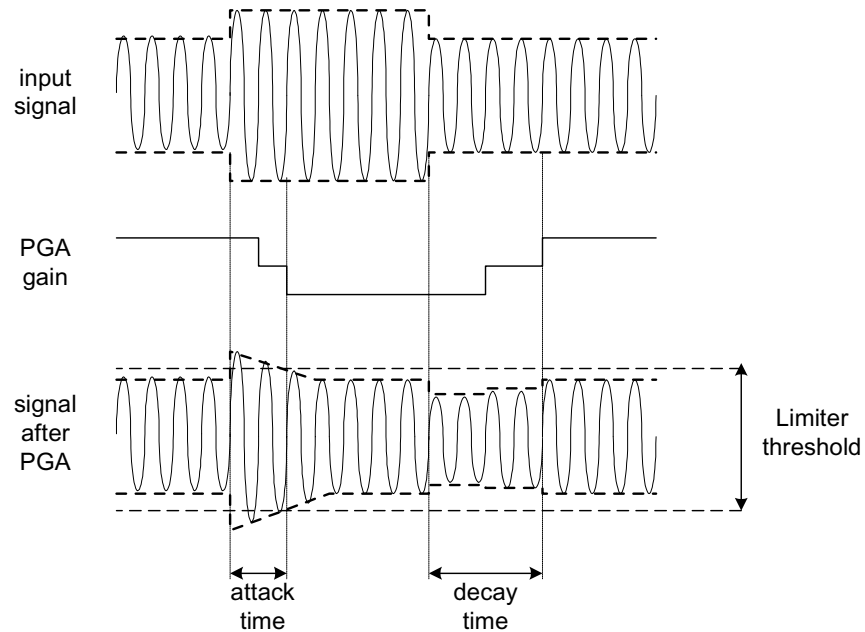

Figure 30 Limiter Operation

In ALC mode, the circuit aims to keep a constant recording volume irrespective of the input signal level. This is achieved by continuously adjusting the PGA gain so that the signal level at the ADC input remains constant. A digital peak detector monitors the ADC output and changes the PGA gain if necessary.

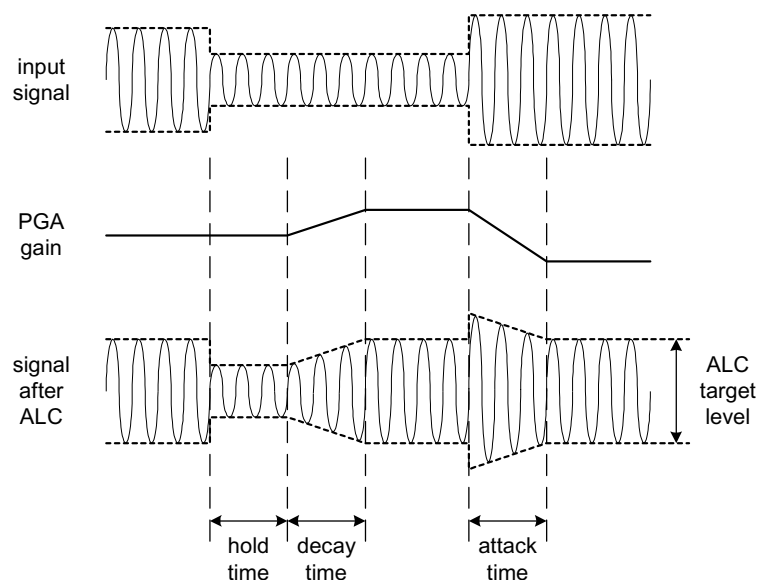

Figure 31 ALC Operation

The gain control circuit is enabled by setting the LCEN control bit. The user can select between Limiter mode and three different ALC modes using the LCSEL control bits.

REGISTER ADDRESS	BIT	LABEL	DEFAULT	DESCRIPTION
(1Eh) ALC Control 2	8	LCEN	0	Enable the PGA gain control circuit. 0 = PGA gain control disabled 1 = PGA gain control enabled
(1Dh) ALC Control 1	8:7	LCSEL[1:0]	00	ALC/Limiter function select 00 = Limiter 01 = ALC Right channel only 10 = ALC Left channel only 11 = ALC Stereo

Table 72 ALC Control Registers

The limiter function only operates in stereo, which means that the peak detector takes the maximum of left and right channel peak values, and any new gain setting is applied to both left and right PGAs, so that the stereo image is preserved. However, the ALC function can also be enabled on one channel only. In this case, only one PGA is controlled by the ALC mechanism, while the other channel runs independently with its PGA gain set through the control register.

When enabled, the threshold for the limiter or target level for the ALC is programmed using the LCT control bits. This allows the threshold/target level to be programmed between -1dB and -16dB in 1dB steps. Note that for the ALC, target levels of -1dB and -2dB give a threshold of -3dB. This is because the ALC can give erroneous operation if the target level is set too high.

REGISTER ADDRESS	BIT	LABEL	DEFAULT	DESCRIPTION
(1Dh) ALC Control 1	3:0	LCT[3:0]	1011 (-6dB)	Limiter Threshold/ALC target level in 1dB steps. 0000 = -16dB FS 0001 = -15dB FS ... 1101 = -3dB FS 1110 = -2dB FS 1111 = -1dB FS

Table 73 Limiter Threshold Register

ATTACK AND DECAY TIMES

The limiter and ALC have different attack and decay times which determine their operation. However, the attack and decay times are defined slightly differently for the limiter and for the ALC. DCY and ATK control the decay and attack times, respectively.

Decay time (Gain Ramp-Up). When in ALC mode, this is defined as the time that it takes for the PGA gain to ramp up across 90% of its range (e.g. from -21dB up to +20 dB). When in limiter mode, it is defined as the time it takes for the gain to ramp up by 6dB.

The decay time can be programmed in power-of-two (2^n) steps. For the ALC this gives times from 33.6ms, 67.2ms, 134.4ms etc. to 34.41s. For the limiter this gives times from 1.2ms, 2.4ms etc., up to 1.2288s. However, the decay time for the limiter can also be made dependant on the input frequency by setting the FDECAY control bit. For a 1kHz input signal this gives decay times of 24ms, 48ms etc., up to 24.576s.

Attack time (Gain Ramp-Down) When in ALC mode, this is defined as the time that it takes for the PGA gain to ramp down across 90% of its range (e.g. from +20dB down to -21dB gain). When in limiter mode, it is defined as the time it takes for the gain to ramp down by 6dB.

The attack time can be programmed in power-of-two (2^n) steps, from 8.4ms, 16.8ms, 33.6ms etc. to 8.6s for the ALC and from 250us, 500us, etc. up to 256ms.

The time it takes for the recording level to return to its target value or static gain value therefore depends on both the attack/decay time and on the gain adjustment required. If the gain adjustment is small, it will be shorter than the attack/decay time.

REGISTER ADDRESS	BIT	LABEL	DEFAULT	DESCRIPTION
(1Fh) ALC Control 3	3:0	ATK[3:0]	0010	LC attack (gain ramp-down) time ALC mode 0000 = 8.4ms 0001 = 16.8ms 0010 = 33.6ms... (time doubles with every step) 1010 or higher = 8.6s Limiter Mode 0000 = 250us 0001 = 500us... 0010 = 1ms (time doubles with every step) 1010 or higher = 256ms
	7:4	DCY[3:0]	0011	LC decay (gain ramp-up) time ALC mode 0000 = 33.5ms 0001 = 67.2ms 0010 = 134.4ms(time doubles for every step) 1010 or higher = 34.41ms Limiter mode 0000 = 1.2ms 0001 = 2.4ms 0010 = 4.8ms(time doubles for every step) 1010 or higher = 1.2288s
	8	FDECAY	0	Frequency dependant decay (limiter only) 0 = Frequency dependent delay disabled 1 = Frequency dependent delay enabled DCY 20kHz input (or disabled) 1kHz input 0000 1.2ms 24ms 0001 2.4ms 28ms 0010 4.8ms 96ms 1010 or higher 1.2288ms 24.576s

Table 74 ALC Attack and Decay Registers

TRANSIENT WINDOW (LIMITER ONLY)

To prevent the limiter responding to short duration high amplitude signals (such as hand-claps in a live performance), the limiter has a programmable transient window preventing it responding to signals above the threshold until their duration exceeds the window period. The Transient window is set in register TRANWIN.

REGISTER ADDRESS	BIT	LABEL	DEFAULT	DESCRIPTION
(21h) Limiter Control	6:4	TRANWIN [2:0]	010	Length of Transient Window 000 = 0us (disabled) 001 = 62.5us 010 = 125us 111 = 4ms

Table 75 Transient Window Register

ZERO CROSS

The PGA has a zero cross detector to prevent gain changes introducing noise to the signal. In ALC mode the register bit ALCZC allows this to be turned on if desired.

REGISTER ADDRESS	BIT	LABEL	DEFAULT	DESCRIPTION
(1Eh) ALC Control 2	7	ALCZC	0 (disabled)	ALC zero cross detection circuit. 0 = Zero cross detection disabled. 1 = Zero cross detection enabled.

Table 76 ALC Zero Cross Register

When the limiter is enabled the zero cross detector on the PGA is automatically enabled to ensure that no noise is introduced during gain changes.

MAXIMUM GAIN (ALC ONLY) AND MAXIMUM ATTENUATION

To prevent low level signals being amplified too much by the ALC, the MAXGAIN register sets the upper limit for the gain. This prevents low level noise being over-amplified. The MAXGAIN register has no effect on the limiter operation.

The MAXATTEN register has different operation for the limiter and for the ALC. For the limiter it defines the maximum attenuation below the static (user programmed) gain. For the ALC, it defines the lower limit for the gain.

REGISTER ADDRESS	BIT	LABEL	DEFAULT	DESCRIPTION
(1Dh) ALC Control 1	6:4	MAXGAIN[2:0]	111 (+24dB)	Set maximum gain for the PGA (ALC only) 111 = +24dB 110 = +20dB(-4dB steps) 010 = +4dB 001 = 0dB 000 = 0dB
(21h) Limiter Control	3:0	MAXATTEN [3:0]	0110	Maximum attenuation of PGA Limiter (attenuation below static) 0000 = -3dB 0001 = -4dB 0010 = -5dB (-1dB steps) 1001 = -12dB ALC (lower PGA gain limit) 1010 or lower = -1dB 1011 = -5dB (-4dB steps) 1110 = -17dB 1111 = -21dB

Table 77 ALC MAXGAIN and MAXATTEN Registers

HOLD TIME (ALC ONLY)

The ALC also has a hold time, which is the time delay between the peak level detected being below target and the PGA gain beginning to ramp up. It can be programmed in power-of-two (2^n) steps, e.g. 2.67ms, 5.33ms, 10.67ms etc. up to 43.7ms. Alternatively, the hold time can also be set to zero. The hold time only applies to gain ramp-up, there is no delay before ramping the gain down when the signal level is above target.

REGISTER ADDRESS	BIT	LABEL	DEFAULT	DESCRIPTION
(1Eh) ALC Control 2	3:0	HLD[3:0]	0000	ALC hold time before gain is increased. 0000 = 0ms 0001 = 2.67ms 0010 = 5.33ms ... (time doubles with every step) 1111 = 43.691s

Table 78 ALC Hold Time Register

OVERLOAD DETECTOR (ALC ONLY)

To prevent clipping when a large signal occurs just after a period of quiet, the ALC circuit includes an overload detector. If the ADC input signal exceeds 87.5% of full scale (-1.16dB), the PGA gain is ramped down at the maximum attack rate (as when ATK = 0000), until the signal level falls below 87.5% of full scale. This function is automatically enabled whenever the ALC is enabled.

(Note: If ATK = 0000, then the overload detector makes no difference to the operation of the ALC. It is designed to prevent clipping when long attack times are used).

NOISE GATE (ALC ONLY)

When the signal is very quiet and consists mainly of noise, the ALC function may cause “noise pumping”, i.e. loud hissing noise during silence periods. The WM8777 has a noise gate function that prevents noise pumping by comparing the signal level at the AINL1/2/3/4/5 and/or AINR1/2/3/4/5 pins against a noise gate threshold, NGTH. The noise gate cuts in when:

- Signal level at ADC [dB] < NGTH [dB] + PGA gain [dB] + Mic Boost gain [dB]

This is equivalent to:

- Signal level at input pin [dB] < NGTH [dB]

When the noise gate is triggered, the PGA gain is held constant (preventing it from ramping up as it would normally when the signal is quiet).

The table below summarises the noise gate control register. The NGTH control bits set the noise gate threshold with respect to the ADC full-scale range. The threshold is adjusted in 6dB steps. Levels at the extremes of the range may cause inappropriate operation, so care should be taken with set-up of the function. Note that the noise gate only works in conjunction with the ALC function, and always operates on the same channel(s) as the ALC (left, right, both, or none).

REGISTER ADDRESS	BIT	LABEL	DEFAULT	DESCRIPTION
(20h) Noise Gate Control	0	NGAT	0	Noise gate function enable 0 = Noise gate disabled 1 = Noise gate enabled
	4:2	NGTH[2:0]	000	Noise gate threshold (with respect to ADC output level) 000 = -78dBFS 001 = -72dBfs ... 6 dB steps 110 = -42dBFS 111 = -30dBFS

Table 79 Noise Gate Registers

Note: The Noise Gate should be set after the ALC to ensure correct operation.

SOFTWARE REGISTER RESET

Writing to register 1111111 will cause a register reset, resetting all register bits to their default values. Note that the WM8777 is powered down by default so writing to this register will power down the device.

REGISTER ADDRESS	BIT	LABEL	DEFAULT	DESCRIPTION
(7Fh) Software reset	8:0	RESET		Writing to this register will apply a reset to the device registers.

Table 80 Software Reset Register

REGISTER MAP

The complete register map is shown below. The detailed description can be found in the relevant text of the device description. The WM8777 can be configured using the Control Interface. All unused bits should be set to '0'.

REGISTER	B15	B14	B13	B12	B11	B10	B9	B8	B7	B6	B5	B4	B3	B2	B1	B0	DEFAULT
R0(00h)	0	0	0	0	0	0	0	UPDATE	FRONTLZCEN	FRONTLA[6:0]						X01101011	
R1(01h)	0	0	0	0	0	0	1	UPDATE	FRONTRZCEN	FRONTRA[6:0]						X01101011	
R2(02h)	0	0	0	0	0	1	0	UPDATE	CNTRZCEN	CNTRA[6:0]						X01101011	
R3(03h)	0	0	0	0	0	1	1	UPDATE	LFEZCEN	LFEA[6:0]						X01101011	
R4(04h)	0	0	0	0	1	0	0	UPDATE	SURLZCEN	SURLA[6:0]						X01101011	
R5(05h)	0	0	0	0	1	0	1	UPDATE	SURLZCEN	SURRA[6:0]						X01101011	
R6(06h)	0	0	0	0	1	1	0	UPDATE	AUXLZCEN	AUXLA[6:0]						X01101011	
R7(07h)	0	0	0	0	1	1	1	UPDATE	AUXRZCEN	AUXRA[6:0]						X01101011	
R8(08h)	0	0	0	1	0	0	0	UPDATE	HPLZCEN	HPLA[6:0]						X01101011	
R9(09h)	0	0	0	1	0	0	1	UPDATE	HPRZCEN	HPRA[6:0]						X01101011	
R10(0Ah)	0	0	0	1	0	1	0	UPDATE	MZCEN	MASTA[6:0]						X01101011	
R11(0Bh)	0	0	0	1	0	1	1	UPDATE	LDA1[7:0]						X11111111		
R12(0Ch)	0	0	0	1	1	0	0	UPDATE	RDA1[7:0]						X11111111		
R13(0Dh)	0	0	0	1	1	0	1	UPDATE	LDA2[7:0]						X11111111		
R14(0Eh)	0	0	0	1	1	1	0	UPDATE	RDA2[7:0]						X11111111		
R15(0Fh)	0	0	0	1	1	1	1	UPDATE	LDA3[7:0]						X11111111		
R16(10h)	0	0	1	0	0	0	0	UPDATE	RDA3[7:0]						X11111111		
R17(11h)	0	0	1	0	0	0	1	UPDATE	LDA4[7:0]						X11111111		
R18(12h)	0	0	1	0	0	1	0	UPDATE	RDA4[7:0]						X11111111		
R19(13h)	0	0	1	0	0	1	1	UPDATE	MASTDA[7:0]						X11111111		
R20(14h)	0	0	1	0	1	0	0	0	PHASE[7:0]						00000000		
R21(15h)	0	0	1	0	1	0	1	PL[3:0]			TOCDAC	0	IZD	DACATC	DZCEN	100100000	
R22(16h)	0	0	1	0	1	1	0	RECREN[1:0]		RECLEN[1:0]		MUTEALL	DMUTE[3:0]			00000000	
R23(17h)	0	0	1	0	1	1	1	0	DZFM[3:0]			DEEMP[3:0]			00000000		
R24(18h)	0	0	1	1	0	0	0	0	MLCKOUT_SRC	MCLKOPEN	PAIFRX_WL[1:0]		PAIFRX_BCP	PAIFRX_LRP	PAIFRX_FMT[1:0]		000100010
R25(19h)	0	0	1	1	0	0	1	PAIFRX_MS	PAIFTX_MS	PAIFRX_RATE[2:0]		DACOSR	PAIFTX_RATE[2:0]			000100010	
R26(1Ah)	0	0	1	1	0	1	0	OSCPD	SPDIFRXD	SPDIFTXD	DACPD[3:0]			ADCPD	PWDN	111111110	
R27(1Bh)	0	0	1	1	0	1	1	SYNC	ADCOSR	ADCHPD	PAIFTX_WL[1:0]		PAIFTX_BCP	PAIFTX_LRP	PAIFTX_FMT[1:0]		000100010
R28(1Ch)	0	0	1	1	1	0	0	Reserved									00000000
R29(1Dh)	0	0	1	1	1	0	1	LCSEL[1:0]		MAXGAIN[2:0]			LCT[3:0]			001111011	
R30(1Eh)	0	0	1	1	1	1	0	LCEN	ALCZC	0	0	0	HLD[3:0]			00000000	
R31(1Fh)	0	0	1	1	1	1	1	FDECAY	DCY[3:0]			ATK[3:0]			100110010		
R32(20h)	0	1	0	0	0	0	0	0	0	0	0	NGTH[2:0]		0	NGAT	00000000	
R33(21h)	0	1	0	0	0	0	1	0	0	TRANWIN[2:0]			MAXATTEN[3:0]			010100110	
R34(22h)	0	1	0	0	0	1	0	0	0	AIN6	FBYP	FBM	FBASS[1:0]		FTRBL[1:0]		00000000
R35(23h)	0	1	0	0	0	1	1	0	CNTR	CNTRGAIN[2:0]			FLFE	FLFEGAIN[2:0]		00000000	

REGISTER	B15	B14	B13	B12	B11	B10	B9	B8	B7	B6	B5	B4	B3	B2	B1	B0	DEFAULT
R36(24h)	0	1	0	0	1	0	0	0	0	0	0	0	REAR	REARGAIN[2:0]		00000000	
R37(25h)	0	1	0	0	1	0	1	0	0	HPSEL	CBYP	CBM	CBASS[1:0]		CTRBL[1:0]	00000000	
R38(26h)	0	1	0	0	1	1	0	0	0	0	0	0	CLFE	CLFEGAIN[2:0]		00000000	
R39(27h)	0	1	0	0	1	1	1	0	0	0	0	0	SURRBYP	SURLBYP	AUXRBYP	AUXLBYP	00000000
R40(28h)	0	1	0	1	0	0	0	UPDATE	0	0	0	0	FBASS[3:0]			00000000	
R41(29h)	0	1	0	1	0	0	1	UPDATE	0	0	0	0	FTREB[3:0]			00000000	
R42(2Ah)	0	1	0	1	0	1	0	UPDATE	0	0	0	0	CBASS[3:0]			00000000	
R43(2Bh)	0	1	0	1	0	1	1	UPDATE	0	0	0	0	CTREB[3:0]			00000000	
R44(2Ch)	0	1	0	1	1	0	0	UPDATEL	UPDATER	UPDATEC	FTLP[1:0]		FTRP[1:0]	CNTP[1:0]		00000000	
R45(2Dh)	0	1	0	1	1	0	1	HPPD	FTRPD	FTLPD	CTRPD	LFEPD	SURRPD	SURLPD	AUXRPD	AUXLPD	11111111
R46(2Eh)	0	1	0	1	1	1	0	ZCLEN	LAG[7:0]							01100111	
R47(2Fh)	0	1	0	1	1	1	1	ZCREN	RAG[7:0]							01100111	
R48(30h)	0	1	1	0	0	0	0	0	0	0	0	0	TOADC	ADC ATC	MUTER	MUTEL	00000000
R49(31h)	0	1	1	0	0	0	1	AINPD	0	0	AIN[5:0]					10000000	
R50(32h)	0	1	1	0	0	1	0	OUTPD2	OUTPD1	0	MX2[2:0]		MX1[2:0]		11000101		
R51(33h)	0	1	1	0	0	1	1	OUTPD4	OUTPD3	0	0	MX4[1:0]	MX3[2:0]		11000101		
R52(34h)	0	1	1	0	1	0	0	PLL_K[8:0]								10010001	
R53(35h)	0	1	1	0	1	0	1	PLL_K[17:9]								10111110	
R54(36h)	0	1	1	0	1	1	0	PLL2TX	PLL2 ADC	PLL2 DAC	0	CLKOUTS RC	PLL_K[21:18]			100001101	
R55(37h)	0	1	1	0	1	1	1	PLL_N[4:0]				PRESCALE	FRAC_E N	POSTSCA LE	PLLPD	00000011	
R56(38h)	0	1	1	1	0	0	0	0	DAC4SEL[1:0]		DAC3SEL[1:0]		DAC2SEL[1:0]		DAC1SEL[1:0]		011100100
R57(39h)	0	1	1	1	0	0	1	0	CHSTMODE[2:0]		PREEMPH[2:0]		CPY_N	AUDIO_N	CON/PRO	00000000	
R58(3Ah)	0	1	1	1	0	1	0	0	CATCODE[7:0]								00000000
R59(3Bh)	0	1	1	1	0	1	1	0	CHNUM2[1:0]		CHNUM1[1:0]	SRCNUM[3:0]			00000000		
R60(3Ch)	0	1	1	1	1	0	0	0	0	0	CLKACU[1:0]	FREQ[3:0]			000110001		
R61(3Dh)	0	1	1	1	1	0	1	0	ORGSAMP[3:0]			TXPAIFRX_WL[1:0]		MAXPAIFR X_WL		000001011	
R62(3Eh)	0	1	1	1	1	1	0	0	0	SAIF_WL [1:0]		SAIF_B CP	SAIF_L RP	SAIF_FMT [1:0]		000100010	
R63(3Fh)	0	1	1	1	1	1	1	0	0	0	SAIFCLKSRC[1:0]		SMS	SAIFRATE[2:0]		000000010	
R64(40h)	1	0	0	0	0	0	0	ADCCL KSRC	ALWAYSVA LID	FILLMODE	RXINSEL[1:0]		0	0	0	SPDINMODE	000000000
R65(41h)	1	0	0	0	0	0	1	0	SAIFSRC[1:0]		PAIFSRC[1:0]	TXRXT HRU	TXSRC[1:0]		RX2DAC	000010000	
R66(42h)	1	0	0	0	0	1	0	0	0	0	FPLL[2:0]		0	0	0	000111000	
R67(43h)	1	0	0	0	0	1	1	Reserved								00000000	
R68(44h)	1	0	0	0	1	0	0	Reserved								00000000	
R69(45h)	1	0	0	0	1	0	1	Reserved								00000000	
R70(46h)	1	0	0	0	1	1	0	Reserved								00000000	
R71(47h)	1	0	0	0	1	1	1	0	GPIO2OP[3:0]			GPIO1OP[3:0]			000010000		
R72(48h)	1	0	0	1	0	0	0	0	GPOMODEOP[3:0]			GPIO3OP[3:0]			010100010		
R73(49h)	1	0	0	1	0	0	1	0	MASK[7:0]							000000000	

REGISTER	B15	B14	B13	B12	B11	B10	B9	B8	B7	B6	B5	B4	B3	B2	B1	B0	DEFAULT	
R74(4Ah)	1	0	0	1	0	1	0	0	0	0	READEN2	READEN3	0	0	0	0	00000000	
R75(4Bh)	1	0	0	1	0	1	1	0	SPDIF_MODE	CPY_N	PCM_N	AUDIO_N	BIP	PARITYERR	VALIDITY	UNLOCK		
R76(4Ch)	1	0	0	1	1	0	0	Read Only 1										
R77(4Dh)	1	0	0	1	1	0	1	Read Only 2										
R78(4Eh)	1	0	0	1	1	1	0	Read Only 3										
R79(4Fh)	1	0	0	1	1	1	1	Read Only 4										
R80(50h)	1	0	1	0	0	0	0	Read Only 5										
R81(51h)	1	0	1	0	0	0	1	Read Only 6										
R127(7Fh)	1	1	1	1	1	1	1	RESET										See Notes
	ADDRESS							DATA										DEFAULT

Table 81 Register Map

Note: Any write to R127 causes a software reset.

REGISTER ADDRESS	BIT	LABEL	DEFAULT	DESCRIPTION
0000000 (00h) Analogue Attenuation FRONTL	6:0	FRONTLA[6:0]	1101011 (0dB)	Analogue Attenuation control for FRONTL in 1dB steps. See Table 60.
	7	FRONTLZCEN	0	FRONTL zero cross detect enable 0 = zero cross disabled 1 = zero cross enabled
	8	UPDATE	Not latched	Controls simultaneous update of all Analogue Attenuation Latches 0 = Store FRONTL in intermediate latch (no change to output) 1 = Store FRONTL and update attenuation on all channels.
0000001 (01h) Analogue Attenuation FRONTR	6:0	FRONTRA[6:0]	1101011 (0dB)	Analogue Attenuation control for FRONTR in 1dB steps. See Table 60.
	7	FRONTRZCEN	0	FRONTR zero cross detect enable 0 = zero cross disabled 1 = zero cross enabled
	8	UPDATE	Not latched	Controls simultaneous update of all Analogue Attenuation Latches 0 = Store FRONTR in intermediate latch (no change to output) 1 = Store FRONTR and update attenuation on all channels.
0000010 (02h) Analogue Attenuation CNTR	6:0	CNTRA[6:0]	1101011 (0dB)	Analogue Attenuation control for CNTR in 1dB steps. See Table 60.
	7	CNTRZCEN	0	CNTR zero cross detect enable 0 = zero cross disabled 1 = zero cross enabled
	8	UPDATE	Not latched	Controls simultaneous update of all Analogue Attenuation Latches 0 = Store CNTR in intermediate latch (no change to output) 1 = Store CNTR and update attenuation on all channels.
0000011 (03h) Analogue Attenuation LFE	6:0	LFEA[6:0]	1101011 (0dB)	Analogue Attenuation control for LFE in 1dB steps. See Table 60.
	7	LFEZCEN	0	LFE zero cross detect enable 0 = zero cross disabled 1 = zero cross enabled
	8	UPDATE	Not latched	Controls simultaneous update of all Analogue Attenuation Latches 0 = Store LFE in intermediate latch (no change to output) 1 = Store LFE and update attenuation on all channels.
0000100 (04h) Analogue Attenuation SURL	6:0	SURLA[6:0]	1101011 (0dB)	Analogue Attenuation control for SURL in 1dB steps. See Table 60.
	7	SURLZCEN	0	SURL zero cross detect enable 0 = zero cross disabled 1 = zero cross enabled
	8	UPDATE	Not latched	Controls simultaneous update of all Analogue Attenuation Latches 0 = Store SURL in intermediate latch (no change to output) 1 = Store SURL and update attenuation on all channels.
0000101 (05h) Analogue Attenuation SURR	6:0	SURRA[6:0]	1101011 (0dB)	Analogue Attenuation control for SUR Right in 1dB steps. Table 60.
	7	SURRZCEN	0	SURR zero cross detect enable 0 = zero cross disabled 1 = zero cross enabled
	8	UPDATE	Not latched	Controls simultaneous update of all Analogue Attenuation Latches 0 = Store SURR in intermediate latch (no change to output) 1 = Store SURR and update attenuation on all channels.

REGISTER ADDRESS	BIT	LABEL	DEFAULT	DESCRIPTION
0000110 (06h) Analogue Attenuation AUXL	6:0	AUXLA[6:0]	1101011 (0dB)	Analogue Attenuation control for AUXL in 1dB steps. See Table 60.
	7	AUXLZCEN	0	AUXL zero cross detect enable 0 = zero cross disabled 1 = zero cross enabled
	8	UPDATE	Not latched	Controls simultaneous update of all Analogue Attenuation Latches 0 = Store AUXL in intermediate latch (no change to output) 1 = Store AUXL and update attenuation on all channels.
0000111 (07h) Analogue Attenuation AUXR	6:0	AUXRA[6:0]	1101011 (0dB)	Analogue Attenuation control for AUXR in 1dB steps. See Table 60.
	7	AUXRZCEN	0	AUXR zero cross detect enable 0 = zero cross disabled 1 = zero cross enabled
	8	UPDATE	Not latched	Controls simultaneous update of all Analogue Attenuation Latches 0 = Store AUXR in intermediate latch (no change to output) 1 = Store AUXR and update attenuation on all channels.
0001000 (08h) Analogue Attenuation HPHONEL	6:0	HPLA[6:0]	1101011 (0dB)	Analogue Attenuation control for HPHONEL in 1dB steps. See Table 60.
	7	HPLZCEN	0	HPHONEL zero cross detect enable 0 = zero cross disabled 1 = zero cross enabled
	8	UPDATE	Not latched	Controls simultaneous update of all Analogue Attenuation Latches 0 = Store HPHONEL in intermediate latch (no change to output) 1 = Store HPHONEL and update attenuation on all channels.
0001001 (09h) Analogue Attenuation HPHONER	6:0	HPRA[6:0]	1101011 (0dB)	Analogue Attenuation control for HPHONER in 1dB steps. See Table 60.
	7	HPRZCEN	0	HPHONER zero cross detect enable 0 = zero cross disabled 1 = zero cross enabled
	8	UPDATE	Not latched	Controls simultaneous update of all Analogue Attenuation Latches 0 = Store HPHONER in intermediate latch (no change to output) 1 = Store HPHONER and update attenuation on all channels.
0001010 (0Ah) Analogue Attenuation Master (all channels)	6:0	MASTA[6:0]	1101011 (0dB)	Analogue Attenuation control for all DAC gains in 1dB steps. See Table 60.
	7	MZCEN	0	Master zero cross detect enable 0 = zero cross disabled 1 = zero cross enabled
	8	UPDATE	Not latched	Controls simultaneous update of all Analogue Attenuation Latches 0 = Store gains in intermediate latch (no change to output) 1 = Store gains and update attenuation on all channels.
0001011 (0Bh) Digital Attenuation DACL1	7:0	LDA1[7:0]	11111111 (0dB)	Digital Attenuation control for DAC1 Left Channel (LSUMOP) in 0.5dB steps. See Table 63
	8	UPDATE	Not latched	Controls simultaneous update of all Attenuation Latches 0 = Store LDA1 in intermediate latch (no change to output) 1 = Store LDA1 and update attenuation on all channels
0001100 (0Ch) Digital Attenuation DACR1	7:0	RDA1[6:0]	11111111 (0dB)	Digital Attenuation control for DAC1 Right Channel (RSUMOP) in 0.5dB steps. See Table 63
	8	UPDATE	Not latched	Controls simultaneous update of all Attenuation Latches 0 = Store RDA1 in intermediate latch (no change to output) 1 = Store RDA1 and update attenuation on all channels.
0001101 (0Dh) Digital Attenuation DACL2	7:0	LDA2[7:0]	11111111 (0dB)	Digital Attenuation control for DAC2 Left Channel (CNTSOP) in 0.5dB steps. See Table 63
	8	UPDATE	Not latched	Controls simultaneous update of all Attenuation Latches 0 = Store LDA2 in intermediate latch (no change to output) 1 = Store LDA2 and update attenuation on all channels.

REGISTER ADDRESS	BIT	LABEL	DEFAULT	DESCRIPTION
0001110 (0Eh) Digital Attenuation DACR2	7:0	RDA2[7:0]	11111111 (0dB)	Digital Attenuation control for DAC2 Right Channel (LFESOP) in 0.5dB steps. See Table 63
	8	UPDATE	Not latched	Controls simultaneous update of all Attenuation Latches 0 = Store RDA2 in intermediate latch (no change to output) 1 = Store RDA2 and update attenuation on all channels.
0001111 (0Fh) Digital Attenuation DACL3	7:0	LDA3[7:0]	11111111 (0dB)	Digital Attenuation control for DAC3 Left Channel (LSURSOP) in 0.5dB steps. See Table 63
	8	UPDATE	Not latched	Controls simultaneous update of all Attenuation Latches 0 = Store LDA3 in intermediate latch (no change to output) 1 = Store LDA3 and update attenuation on all channels.
0010000 (10h) Digital Attenuation DACR3	7:0	RDA3[7:0]	11111111 (0dB)	Digital Attenuation control for DAC3 Right Channel (RSURSOP) in 0.5dB steps. See Table 63
	8	UPDATE	Not latched	Controls simultaneous update of all Attenuation Latches 0 = Store RDA3 in intermediate latch (no change to output) 1 = Store RDA3 and update attenuation on all channels.
0010001 (11h) Digital Attenuation DACL4	7:0	LDA4[7:0]	11111111 (0dB)	Digital Attenuation control for DAC4 Left Channel (LAUXSOP) in 0.5dB steps. See Table 63
	8	UPDATE	Not latched	Controls simultaneous update of all Attenuation Latches 0 = Store LDA4 in intermediate latch (no change to output) 1 = Store LDA4 and update attenuation on all channels.
0010010 (12h) Digital Attenuation DACR4	7:0	RDA4[7:0]	11111111 (0dB)	Digital Attenuation control for DAC4 Right Channel (RAUXSOP) in 0.5dB steps. See Table 63
	8	UPDATE	Not latched	Controls simultaneous update of all Attenuation Latches 0 = Store RDA4 in intermediate latch (no change to output) 1 = Store RDA4 and update attenuation on all channels.
0010011 (13h) Digital Attenuation Master (all channels)	7:0	MASTDA[7:0]	11111111 (0dB)	Digital Attenuation control for all DAC channels in 0.5dB steps. See Table 63
	8	UPDATE	Not latched	Controls simultaneous update of all Attenuation Latches 0 = Store gain in intermediate latch (no change to output) 1 = Store gain and update attenuation on all channels.
0010100 (14h) DAC Output Phase	7:0	PHASE[7:0]	00000000	Controls phase of DAC outputs PHASE[0] = 1 inverts phase of DAC1L output PHASE[1] = 1 inverts phase of DAC1R output PHASE[2] = 1 inverts phase of DAC2L output PHASE[3] = 1 inverts phase of DAC2R output PHASE[4] = 1 inverts phase of DAC3L output PHASE[5] = 1 inverts phase of DAC3R output PHASE[6] = 1 inverts phase of DAC4L output PHASE[7] = 1 inverts phase of DAC4R output
0010101 (15h) DAC Attenuation Control	0	DZCEN	0	DAC Digital Volume Zero Cross Enable: 0 = Zero Cross detect disabled 1 = Zero Cross detect enabled
	1	DACATC	0	Attenuator Control 0 = All DACs use attenuations as programmed. 1 = Right channel DACs use corresponding left DAC attenuations
	2	IZD	0	Infinite zero detection circuit control and automute control 0 = Infinite zero detect automute disabled 1 = Infinite zero detect automute enabled
	4	TOCDAC	0	DAC Analogue Zero cross detect timeout disable 0 = Timeout enabled 1 = Timeout disabled

REGISTER ADDRESS	BIT	LABEL	DEFAULT	DESCRIPTION					
	8:5	PL[3:0]	1001	DAC Output Control					
				PL[3:0]	Left Output	Right Output	PL[3:0]	Left Output	Right Output
				0000	Mute	Mute	1000	Mute	Right
				0001	Left	Mute	1001	Left	Right
				0010	Right	Mute	1010	Right	Right
				0011	(L+R)/2	Mute	1011	(L+R)/2	Right
				0100	Mute	Left	1100	Mute	(L+R)/2
				0101	Left	Left	1101	Left	(L+R)/2
0110	Right	Left	1110	Right	(L+R)/2				
0111	(L+R)/2	Left	1111	(L+R)/2	(L+R)/2				
0010110 (16h) Mute Control	3:0	DMUTE[3:0]	0000	DAC channel soft mute enables: DMUTE[0] = 1, enable softmute on DAC1. DMUTE[1] = 1, enable softmute on DAC2. DMUTE[2] = 1, enable softmute on DAC3. DMUTE[3] = 1, enable softmute on DAC4.					
	4	MUTEALL	0	DAC channel master soft mute. Mutes all DAC channels: 0 = disable softmute on all DACs. 1 = enable softmute on all DACs.					
	6:5	RECLLEN	00	RECL Output Enable 00 = REC output muted 01 = REC output ADCL 10 = REC output DAC1L					
	8:7	RECREN	00	RECR Output Enable 00 = REC output muted 01 = REC output ADCR 10 = REC output DAC1R					
0010111 (17h) DAC Control	3:0	DEEMPH[3:0]	0000	De-emphasis mode select: DEEMPH[0] = 1, enable De-emphasis on DAC1. DEEMPH[1] = 1, enable De-emphasis on DAC2. DEEMPH[2] = 1, enable De-emphasis on DAC3. DEEMPH[3] = 1, enable De-emphasis on DAC4.					
	7:4	DZFM[3:0]	0000	Selects the output for ZFLG1 and ZFLG2 pins (see Table 53). 1 = indicates 1024 consecutive zero input samples on the channels selected 0 = indicates at least one of selected channels has non zero sample in last 1024 inputs					
0011000 (18h) Primary Interface Control (RX)	1:0	PAIFRX_FMT [1:0]	10	Interface format select 00 = right justified mode 01 = left justified mode 10 = I ² S mode 11 = DSP (early or late) mode					
	2	PAIFRX_LRP	0	PDATAIPLRC Polarity or DSP Early/Late mode select					
				Left Justified / Right Justified / I ² S 0 = Standard PDATAIPLRC Polarity 1 = Inverted PDATAIPLRC Polarity	DSP Mode 0 = Early DSP mode 1 = Late DSP mode				
3	PAIFRX_BCP	0	PBCLK Polarity 0 = Normal - DIN[3:0], PDATAIPLRC and PDATAOPLRC sampled on rising edge of PBCLK; PDATAOP changes on falling edge of PBCLK. 1 = Inverted - DIN[3:0], PDATAIPLRC and PDATAOPLRC sampled on falling edge of PBCLK; PDATAOP changes on rising edge of PBCLK.						

REGISTER ADDRESS	BIT	LABEL	DEFAULT	DESCRIPTION
	5:4	PAIFRX_WL [1:0]	10	Input Word Length 00 = 16-bit Mode 01 = 20-bit Mode 10 = 24-bit Mode 11 = 32-bit Mode (not supported in right justified mode)
	6	MCLKOPEN	0	MCLK pin output enable 0 = MCLK pin is an input 1 = MCLK pin is an output (see MCLKOUTSRC below)
	7	MCLKOUTSRC	0	MCLK pin output source 0 = PLL 1 = Crystal clock output.
0011001 (19h) Master Mode Control	2:0	PAIFTX_RATE [2:0]	010	Master Mode MCLK:PDATAOPLRC ratio select: 000 = 128fs 001 = 192fs 010 = 256fs 011 = 384fs 100 = 512fs 101 = 768fs 110 = 1152fs
	3	DACOSR	0	DAC oversample rate select: 0 = 128x oversampling 1 = 64x oversampling
	6:4	PAIFRX_RATE [2:0]	010	Master Mode MCLK:PDATAIPLRC ratio select: 000 = 128fs 001 = 192fs 010 = 256fs 011 = 384fs 100 = 512fs 101 = 768fs 110 = 1152fs
	7	PAIFTX_MS	0	Master/Slave Interface mode select. If ADCCLKSRC is set high then this register control whether the ADC clocks are in master or slave mode/ 0 = Slave Mode – PDATAOPLRC and ADCPBCLK are inputs 1 = Master Mode – PDATAOPLRC and ADCPBCLK are outputs
	8	PAIFRX_MS	0	Maser/Slave interface mode select 0 = Slave Mode – PDATAOPLRC, PDATAIPLRC and PBCLK are inputs 1 = Master Mode – PDATAOPLRC, PDATAIPLRC and PBCLK are outputs Note if ADCCLKSRC is set high then this register only controls PDATAIPLRC and PBCLK.
	0011010 (1Ah) Powerdown Control	0	PWDN	0
1		ADCPD	1	ADC powerdown: 0 = ADC enabled 1 = ADC disabled
5:2		DACPD[3:0]	1111	DAC powerdowns (0 = DAC enabled, 1 = DAC disabled) DACPD[0] = DAC1 DACPD[1] = DAC2 DACPD[2] = DAC3 DACPD[3] = DAC4

REGISTER ADDRESS	BIT	LABEL	DEFAULT	DESCRIPTION	
	6	SPDIF_TXD	1	SPDIF_TX powerdown 0 = SPDIF_TX enabled 1 = SPDIF_TX disabled	
	7	SPDIF_RXD	1	SPDIF_RX powerdown 0 = SPDIF_RX enabled 1 = SPDIF_RX disabled	
	8	OSCPD	1	OSC power down 0 = Oscillator enabled 1 = Oscillator disabled	
0011011 (1Bh) Primary Interface Control (TX)	1:0	PAIFTX_FMT [1:0]	10	Interface format select 00 = right justified mode 01 = left justified mode 10 = I ² S mode 11 = DSP (early or late) mode	
	2	PAIFTX_LRP	0	PDATAOPLRC Polarity or DSP Early/Late mode select Left Justified / Right Justified / I ² S 0 = Standard PDATAOPLRC Polarity 1 = Inverted PDATAOPLRC Polarity DSP Mode 0 = Early DSP mode 1 = Late DSP mode	
	3	PAIFTX_BCP	0	ADCPBCLK/PBCLK Polarity 0 = Normal ADCPBCLK/PBCLK. 1 = Inverted ADCPBCLK/PBCLK.	
	5:4	PAIFTX_WL [1:0]	10	Input Word Length 00 = 16-bit Mode 01 = 20-bit Mode 10 = 24-bit Mode 11 = 32-bit Mode (not supported in right justified mode)	
	6	ADCHPD	0	ADC Highpass Filter Disable: 0 = Highpass Filter enabled 1 = Highpass Filter disabled	
	7	ADCOSR	0	ADC oversample rate select 0 = 128x oversampling 1 = 64x oversampling	
	8	SYNC	0	Sync ADC and DAC together. 0 = Enable SYNC function 1 = Disable Sync function	
	0011101 (1Dh) ALC Control 1	3:0	LCT[3:0]	1011 (-6dB)	Limiter threshold/ALC target level in 1dB steps. 0000: -16dB FS 0001: -15dB FS ... 1101: -3dB FS 1110: -2dB FS 1111: -1dB FS
		6:4	MAXGAIN[2:0]	111 (+24dB)	Set Maximum Gain of PGA 111 = +24dB 110 = +20dB ...(-4dB steps) 010 = +4dB 001 = 0dB 000 = 0dB
8:7		LCSEL[1:0]	00 (OFF)	ALC/Limiter function select 00 = Limiter 01 = ALC Right channel only 10 = ALC Left channel only 11 = ALC Stereo (PGA registers unused)	

REGISTER ADDRESS	BIT	LABEL	DEFAULT	DESCRIPTION																	
0011110 (1Eh) ALC Control 2	3:0	HLD[3:0]	0000 (0MS)	ALC hold time before gain is increased. 0000 = 0ms 0001 = 2.67ms 0010 = 5.33ms ... (time doubles with every step) 1111 = 43.691s																	
	7	ALCZC	0	ALC zero cross detection circuit. 0 = Zero cross detection disabled. 1 = Zero cross detection enabled.																	
	8	LCEN	0	Enable the PGA gain control circuit. 0 = PGA gain control disabled 1 = PGA gain control enabled																	
0011111 (1Fh) ALC Control 3	3:0	ATK[3:0]	0010 (33ms/1ms)	ALC/Limiter attack (gain ramp down) time																	
				<table border="1"> <tr> <td>ACL mode</td> <td>Limiter mode</td> </tr> <tr> <td>0000 = 8.4ms</td> <td>0000 = 250us</td> </tr> <tr> <td>0001 = 16.8ms</td> <td>0001 = 500us</td> </tr> <tr> <td>0010 = 33.6ms..</td> <td>0010 = 1ms</td> </tr> <tr> <td>(time doubles with every step)</td> <td>(time doubles with every step)</td> </tr> <tr> <td>1010 or higher = 8.6s</td> <td>1010 or higher = 256ms</td> </tr> </table>	ACL mode	Limiter mode	0000 = 8.4ms	0000 = 250us	0001 = 16.8ms	0001 = 500us	0010 = 33.6ms..	0010 = 1ms	(time doubles with every step)	(time doubles with every step)	1010 or higher = 8.6s	1010 or higher = 256ms					
	ACL mode	Limiter mode																			
	0000 = 8.4ms	0000 = 250us																			
	0001 = 16.8ms	0001 = 500us																			
	0010 = 33.6ms..	0010 = 1ms																			
(time doubles with every step)	(time doubles with every step)																				
1010 or higher = 8.6s	1010 or higher = 256ms																				
7:4	DCY[3:0]	0011	ALC/Limiter decay (gain ramp up) time																		
			<table border="1"> <tr> <td>ACL mode</td> <td>Limiter mode</td> </tr> <tr> <td>0000 = 33.5ms</td> <td>0000 = 1.2ms</td> </tr> <tr> <td>0001 = 67.2ms</td> <td>0001 = 2.4ms</td> </tr> <tr> <td>0010 = 134.4ms..</td> <td>0010 = 4.8ms</td> </tr> <tr> <td>(time doubles with every step)</td> <td>(time doubles with every step)</td> </tr> <tr> <td>1010 or higher = 34.41s</td> <td>1010 or higher = 1.2288s</td> </tr> </table>	ACL mode	Limiter mode	0000 = 33.5ms	0000 = 1.2ms	0001 = 67.2ms	0001 = 2.4ms	0010 = 134.4ms..	0010 = 4.8ms	(time doubles with every step)	(time doubles with every step)	1010 or higher = 34.41s	1010 or higher = 1.2288s						
ACL mode	Limiter mode																				
0000 = 33.5ms	0000 = 1.2ms																				
0001 = 67.2ms	0001 = 2.4ms																				
0010 = 134.4ms..	0010 = 4.8ms																				
(time doubles with every step)	(time doubles with every step)																				
1010 or higher = 34.41s	1010 or higher = 1.2288s																				
8	FDECAY	0	Frequency dependant decay enable (Limiter only) 0 = Frequency dependent decay disabled 1 = Frequency dependent decay enabled																		
			<table border="1"> <tr> <td>DCY</td> <td>20KHz input (or disabled)</td> <td>1KHz input</td> </tr> <tr> <td>0000</td> <td>1.2ms</td> <td>24ms</td> </tr> <tr> <td>0001</td> <td>2.4ms</td> <td>48ms</td> </tr> <tr> <td>0010</td> <td>4.8ms</td> <td>96ms</td> </tr> <tr> <td>.....</td> <td>.....</td> <td>.....</td> </tr> <tr> <td>1010 or higher</td> <td>1.2288s</td> <td>24.576s</td> </tr> </table>	DCY	20KHz input (or disabled)	1KHz input	0000	1.2ms	24ms	0001	2.4ms	48ms	0010	4.8ms	96ms	1010 or higher	1.2288s	24.576s
			DCY	20KHz input (or disabled)	1KHz input																
0000	1.2ms	24ms																			
0001	2.4ms	48ms																			
0010	4.8ms	96ms																			
.....																			
1010 or higher	1.2288s	24.576s																			
0100000 (20h) Noise Gate Control	0	NGAT	0	Noise gate enable (ALC only) 0 = Noise gate disabled 1 = Noise gate enabled																	
	4:2	NGTH[2:0]	000	Noise gate threshold 000 = -78dBFS 001 = -72dBfs ... 6 dB steps 110 = -42dBFS 111 = -36dBFS																	
0100001 (21h) Limiter Control	3:0	MAXATTEN [3:0]	0110	Maximum attenuation of PGA																	
				<table border="1"> <tr> <td>ALC (lower PGA gain limit)</td> <td>Limiter (attenuation below static)</td> </tr> <tr> <td>1010 or lower = -1dB</td> <td>0000 = -3dB</td> </tr> <tr> <td>1011 = -5dB</td> <td>0001 = -4dB</td> </tr> <tr> <td>..... (-4dB steps)</td> <td>0010 = -5dB</td> </tr> <tr> <td>1110 = -17dB</td> <td>.... (-1dB steps)</td> </tr> <tr> <td>1111 = -21dB</td> <td>1001 = -12dB</td> </tr> </table>	ALC (lower PGA gain limit)	Limiter (attenuation below static)	1010 or lower = -1dB	0000 = -3dB	1011 = -5dB	0001 = -4dB (-4dB steps)	0010 = -5dB	1110 = -17dB (-1dB steps)	1111 = -21dB	1001 = -12dB					
ALC (lower PGA gain limit)	Limiter (attenuation below static)																				
1010 or lower = -1dB	0000 = -3dB																				
1011 = -5dB	0001 = -4dB																				
..... (-4dB steps)	0010 = -5dB																				
1110 = -17dB (-1dB steps)																				
1111 = -21dB	1001 = -12dB																				

REGISTER ADDRESS	BIT	LABEL	DEFAULT	DESCRIPTION
	6:4	TRANWIN [2:0]	010	Length of Transient Window 000 = 0us (disabled) 001 = 62.5us 010 = 125us 111 = 4ms
0100010 (22h) FRONT Mixer Control 1	1:0	FTRBL[1:0]	00	Control treble boost and cut:- 00 = both off (Amps disabled) 01 = Treble cut 10 = Treble boosted 11 = both off (Amps enabled)
	3:2	FBASS[1:0]	00	Controls bass boost and cut:- 00 = both off (Amps disabled) 01 = Bass cut 10 = Bass boosted 11 = both off (Amps enabled)
	4	FBM	0	Bass managed signal path select 0 = Path disabled 1 = Path enabled
	5	FBYP	0	Bypass signal path select 0 = Path disabled 1 = Path enabled
	6	AIN6	0	0 = AIN6 not selected 1 = AIN6 applied to FRONT channels
0100011 (23h) FRONT Mixer Control 2	2:0	FLFEGAIN[2:0]	000	Front LFE gain: 000 = 0dB 001 = 1dB 010 = 2dB 011 = 3dB 100 = 4dB 101 = 4.5dB 110 = 5dB 111 = 6dB
	3	FLFE	0	LFE signal path select 0 = Path disabled 1 = Path enabled
	6:4	CNTRGAIN[2:0]	000	Front CNTR gain: 000 = 0dB 001 = 1dB 010 = 2dB 011 = 3dB 100 = 4dB 101 = 4.5dB 110 = 5dB 111 = 6dB
	7	CNTR	0	Center signal path mix 0 = Path disabled 1 = Path enabled
0100100 (24h) FRONT Mixer Control 3	2:0	REARGAIN[2:0]	000	Front REAR gain: 000 = 0dB 001 = 1dB 010 = 2dB 011 = 3dB 100 = 4dB 101 = 4.5dB 110 = 5dB 111 = 6dB

REGISTER ADDRESS	BIT	LABEL	DEFAULT	DESCRIPTION
	3	REAR	0	Rear signal path mix 0 = Path disabled 1 = Path enabled
0100101 (25h) Center Mixer Control 1	1:0	CTRBL[1:0]	00	Control treble boost and cut: 00 = both off (Amps disabled) 01 = Treble cut 10 = Treble boosted 11 = both off (Amps enabled)
	3:2	CBASS[1:0]	00	Controls bass boost and cut:- 00 = both off (Amps disabled) 01 = Bass cut 10 = Bass boosted 11 = both off (Amps enabled)
	4	CBM	0	Bass managed signal path select 0 = Path disabled 1 = Path enabled
	5	CBYP	0	Bypass signal path select 0 = Path disabled 1 = Path enabled
	6	HPSEL	0	Controls headphone output MUX:- 0 = FRONTL/R output on headphone channels 1 = AUXL/R output on headphone channels
0100110 (26h) Center Mixer Control 2	2:0	CLFEGAIN[2:0]	000	Center LFE gain: 000 = 0dB 001 = 1dB 010 = 2dB 011 = 3dB 100 = 4dB 101 = 4.5dB 110 = 5dB 111 = 6dB
	3	CLFE	0	LFE signal path select: 0 = Path disabled 1 = Path enabled
0100111 (27h) Bass Management Bypass	0	AUXLBYP	0	Bypass select for AUX left output 0 = Bass managed 1 = Bypass
	1	AUXRBYP	0	Bypass select for AUX right output 0 = Bass managed 1 = Bypass
	2	SURLBYP	0	Bypass select for surround left output 0 = Bass managed 1 = Bypass
	3	SURRBYP	0	Bypass select for surround right output 0 = Bass managed 1 = Bypass
0101000 (28h) Front Bass Control	3:0	FBASS[3:0]	0000	Gain control for Bass boost/cut – see table 3
	8	UPDATE	Not latched	Controls simultaneous update of all Attenuation Latches 0 = Store GAIN FRONT BASS in intermediate latch (no change to output) 1 = Store GAIN FRONT BASS and update attenuation on all channels.
0101001	3:0	FTREB[3:0]	0000	Gain control for Bass boost/cut – see table 3

REGISTER ADDRESS	BIT	LABEL	DEFAULT	DESCRIPTION
(29h) Front Treble Control	8	UPDATE	Not latched	Controls simultaneous update of all Attenuation Latches 0 = Store GAIN FRONT TREBLE in intermediate latch (no change to output) 1 = Store GAIN FRONT TREBLE and update attenuation on all channels.
0101010 (2Ah) Center Bass Control	3:0	CBASS[3:0]	0000	Gain control for Bass boost/cut – see table 3
	8	UPDATE	Not latched	Controls simultaneous update of all Attenuation Latches 0 = Store GAIN CENTER BASS in intermediate latch (no change to output) 1 = Store GAIN CENTER BASS and update attenuation on all channels.
0101011 (2Bh) Center Treble Control	3:0	CTREB[3:0]	0000	Gain control for Bass boost/cut – see table 3
	8	UPDATE	Not latched	Controls simultaneous update of all Attenuation Latches 0 = Store GAIN CENTER TREBLE in intermediate latch (no change to output) 1 = Store GAIN CENTER TREBLE and update attenuation on all channels.
0101100 (2Ch) Mixer Pregain	1:0	CNTP[1:0]	00	PREGAIN control for CNTR control channel 00 = 0dB Attenuation 01 = -6dB Attenuation 10 = -12dB Attenuation 11 = -18dB Attenuation
	3:2	FTRP[1:0]	00	PREGAIN control for FRONTR tone control channel 00 = 0dB Attenuation 01 = -6dB Attenuation 10 = -12dB Attenuation 11 = -18dB Attenuation
	5:4	FTLP[1:0]	00	PREGAIN control for FRONTL tone control channel 00 = 0dB Attenuation 01 = -6dB Attenuation 10 = -12dB Attenuation 11 = -18dB Attenuation
	6	UPDATEC	0	Controls simultaneous update of all Attenuation Latches 0 = Store PREGAIN CNTR in intermediate latch (no change to output) 1 = Store PREGAIN CNTR and update attenuation on all channels.
	7	UPDATER	0	Controls simultaneous update of all Attenuation Latches 0 = Store PREGAIN RIGHT in intermediate latch (no change to output) 1 = Store PREGAIN RIGHT and update attenuation on all channels.
	8	UPDATEL	0	Controls simultaneous update of all Attenuation Latches 0 = Store PREGAIN LEFT in intermediate latch (no change to output) 1 = Store PREGAIN LEFT and update attenuation on all channels.
	0101101 (2Dh) Output Powerdown	0	AUXLPD	1
1		AUXRPD	1	Auxiliary right output powerdown. 0 = powerup 1 = powerdown
2		SURLPD	1	Surround left output powerdown. 0 = powerup 1 = powerdown

REGISTER ADDRESS	BIT	LABEL	DEFAULT	DESCRIPTION
	3	SURRPD	1	Surround Right output powerdown. 0 = powerup 1 = powerdown
	4	LFEPD	1	LFE output powerdown. 0 = powerup 1 = powerdown
	5	CTRPD	1	Center output powerdown. 0 = powerup 1 = powerdown
	6	FRTLDP	1	Front Left output powerdown. 0 = powerup 1 = powerdown
	7	FRTRPD	1	Front Right output powerdown. 0 = powerup 1 = powerdown
	8	HPPD	1	Headphone output powerdown. 0 = powerup 1 = powerdown
0101110 (2Eh) Attenuation ADC Left	7:0	LAG[7:0]	11001111 (0dB)	Attenuation control for left channel ADC gain in 0.5dB steps. See Table 68
	8	ZCLEN	0	Zero Cross enable for left channel ADC 0 = Disable Zero Cross 1 = Enable Zero Cross
0101111 (2Fh) Attenuation ADC Right	7:0	RAG[7:0]	11001111 (0dB)	Attenuation control for right channel ADC gain in 0.5dB steps. See Table 68
	8	ZCREN	0	Zero Cross enable for right channel ADC 0 = Disable Zero Cross 1 = Enable Zero Cross
0110000 (30h) Attenuation Control	0	MUTEL	0	Left Channel mute control 0 = Channel not muted 1 = Channel muted
	1	MUTER	0	Left Channel mute control 0 = Channel not muted 1 = Channel muted
	2	ADCATC	0	Attenuator Control 0 = ADC use attenuations as programmed. 1 = Right channel ADC use corresponding left ADC attenuations
	3	TOADC	0	Time out clock enable/disable 0 = Time out clock enabled. 1 = Time out clock disabled.

REGISTER ADDRESS	BIT	LABEL	DEFAULT	DESCRIPTION
0110001 (31h) ADC Mux and Powerdown Control	5:0	AIN[5:0]	00000	ADC left channel input mux control bits 00000 = UTE 00001 = AIN1 00010 = AIN2 00011 = AIN1 + AIN2 11111 = AIN1 + AIN2 + AIN3 + AIN4 + AIN5 + AIN6
	8	AINPD	1	Input mux and buffer powerdown 0 = Input mux and buffer enabled 1 = Input mux and buffer powered down
0110010 (32h) Output Mux and Powerdown Control 1	2:0	MX1[2:0]	001	VOUT1 Output select (see Figure 28)
	5:3	MX2[2:0]	001	VOUT2 Output select (see Figure 28)
	7	OUTPD1	1	Mixer Powerdown select 0 = Powerup 1 = Powerdown
	8	OUTPD2	1	Mixer Powerdown select 0 = Powerup 1 = Powerdown
0110011 (33h) Output Mux and Powerdown Control 2	2:0	MX3[2:0]	001	VOUT3 Output select (see Figure 28)
	4:3	MX4[1:0]	01	VOUT4 Output select (see Figure 29)
	7	OUTPD3	1	Mixer Powerdown select 0 = Powerup 1 = Powerdown
	8	OUTPD4	1	Mixer Powerdown select 0 = Powerup 1 = Powerdown
0110100 (34h) PLL Control 1	8:0	PLL_K[8:0]	121 (Hex)	Fractional (K) part of PLL input/output frequency ratio (bits 8:0).
0110101 (35h) PLL Control 2	8:0	PLL_K[17:9]	17E (Hex)	Fractional (K) part of PLL input/output frequency ratio (bits 17:9).
0110110 (36h) PLL Control 3	3:0	PLL_K[21:18]	D(Hex)	Fractional (K) part of PLL input/output frequency ratio (bits 21:18)
	4	CLKOUTSRC	0	CLKOUT pin source:- 0 = PLL clock output 1 = Crystal clock output.
	6	PLL2DAC	0	DAC clock source 0 = MCLK pin 1 = PLL clock
	7	PLL2ADC	0	ADC clock source 0 = MCLK or ADCMCLK pin 1 = PLL clock
	8	PLL2TX	1	S/PDIF TX clock source 0 = MLCK or ADCMCLK pin 1 = PLL clock
0110111 (37h) PLL Control 4	0	PLLPD	1	0 = Enable PLL 1 = Disable PLL
	1	POSTSCALE	0	0 = no post scale 1 = divide MCLK by 2 after PLL
	2	FRAC_EN	0	0 = Integer N only PLL 1 = Integer N and Fractional K PLL
	3	PRESCALE	0	0 = no pre-scale 1 = divide MCLK by 2 prior to PLL
	8:4	PLL_N[4:0]	00000	Integer (N) divisor part of PLL input/output frequency ratio. Use values greater than 5 and less than 13.

REGISTER ADDRESS	BIT	LABEL	DEFAULT	DESCRIPTION	
0111000 (38h) DAC Digital Input Selector	1:0	DAC1SEL[1:0]	00	DAC digital input select. 00 = DAC takes data from PDATAIP1 01 = DAC takes data from PDATAIP2 10 = DAC takes data from PDATAIP3 11 = DAC takes data from PDATAIP4	
	3:2	DAC2SEL[1:0]	01		
	5:4	DAC3SEL[1:0]	10		
	7:6	DAC4SEL[1:0]	11		
0111001 (39h) S/PDIF Transmitter Channel Bit Control 1	0	CON/PRO	0	0 = Consumer Mode 1 = Professional Mode (not supported by WM8777)	
	1	AUDIO_N	0	0 = S/PDIF transmitted data is audio PCM. 1 = S/PDIF transmitted data is not audio PCM.	
	2	CPY_N	0	0 = Transmitted data has copyright asserted. 1 = Transmitted data has no copyright assertion.	
	5:3	PREEMPH[2:0]	000	000 = Data from Audio interface has no pre-emphasis. 001 = Data from Audio interface has pre-emphasis. 010 = Reserved (Audio interface has pre-emphasis). 011 = Reserved (Audio interface has pre-emphasis). All other modes are reserved and should not be used.	
	7:6	CHSTMODE[1:0]	00	S/PDIF Channel status bits. 00 = Only valid mode for consumer applications. All other modes are reserved.	
0111010 (3Ah) S/PDIF Transmitter Channel Bit Control 2	7:0	CATCODE[7:0]	00000000	Category Code. Refer to S/PDIF specification for details. 00h indicates "general" mode.	
0111011 (3Bh) S/PDIF Transmitter Channel Bit Control 3	3:0	SRCNUM[3:0]	0000	Source Number. No definitions are attached to data. See S/PDIF specification for details.	
				5:4	CHNUM1[1:0]
	CHNUM1	Channel Status Bits[23:20]			
	00	0000: Do not use channel number			
	01	0001: Send to Left Channel			
	10	0010: Send to Right Channel			
	11	0000: Do not use channel number			
	7:6	CHNUM2[1:0]	00	Channel Number for Subframe 2	
				CHNUM2	Channel Status Bits[23:20]
				00	0000: Do not use channel number
01				0001: Send to Left Channel	
10				0010: Send to Right Channel	
11	0000: Do not use channel number				
0111100 (3Ch) S/PDIF Transmitter Channel Bit Control 4	3:0	FREQ[3:0]	0001	Sampling Frequency. See S/PDIF specification for details. 0001 = Sampling Frequency not indicated.	
	5:4	CLKACU[1:0]	11	Clock Accuracy of Generated clock. 00 = Level II 01 = Level I 10 = Level III 11 = Interface frame rate not matched to sampling frequency.	
0111101 (3Dh) S/PDIF	0	MAXPAIFRX_WL	1	Maximum Audio sample word length 0 = 20 bits 1 = 24 bits	

REGISTER ADDRESS	BIT	LABEL	DEFAULT	DESCRIPTION		
	3:1	TXPAIFRX_WL [2:0]	101	Audio Sample Word Length. 000 = Word Length Not Indicated		
				TXPAIFRX_WL	MAXPAIFRX_WL= =1	MAXPAIFRX_WL= =0
				001	20 bits	16 bits
				010	22 bits	18 bits
				100	23 bits	19 bits
				101	24 bits	20 bits
				110	21 bits	17 bits
	All other combinations reserved					
	7:4	ORGSAMP[3:0]	0000	Original Sampling Frequency. See S/PDIF specification for details. 0000 = original sampling frequency not indicated		
0111110 (3Eh) Secondary Interface Control	1:0	SAIF_FMT [1:0]	10	Secondary Audio Interface format select 00 = right justified mode 01 = left justified mode 10 = I ² S mode 11 = DSP (early or late) mode		
	2	SAIF_LRP	0	SLRCLK Polarity or DSP Early/Late mode select Left Justified / Right Justified/ I ² S 0 = Standard PDATAIPLRC Polarity 1 = Inverted PDATAIPLRC Polarity DSP Mode 0 = Early DSP mode 1 = Late DSP mode		
	3	SAIF_BCP	0	SBCLK Polarity 0 = Normal SBCLK. 1 = Inverted SBCLK.		
	5:4	SAIF_WL [1:0]	10	Input Word Length 00 = 16-bit Mode 01 = 20-bit Mode 10 = 24-bit Mode 11 = 32-bit Mode (not supported in right justified mode)		
0111111 (3Fh) Secondary Interface Master Mode Control	2:0	SAIFRATE[2:0]	010	Master Mode MCLK:SLRC ratio select: 000 = 128fs 001 = 192fs 010 = 256fs 011 = 384fs 100 = 512fs 101 = 768fs 110 = 1152fs		
	3	SMS	0	Maser/Slave interface mode select 0 = Slave Mode – SLRC and SBCLK are inputs 1 = Master Mode – SLRC and SBCLK are outputs		
	5:4	SAIFCLKSRC[1:0]	00	Audio interface master clock source when SMS is 1. 00 = MCLK 01 = GPIO (If ADCCLKSRC is set) 10 = PLL clock 11 = PLL clock		
1000000 (40h) S/PDIF Receiver	0	SPDINMODE	0	Selects the input circuit type for the S/PDIF input 0 = Normal CMOS input 1 = Comparator input. Compatible with 200mV AC coupled consumer S/PDIF input signals.		

REGISTER ADDRESS	BIT	LABEL	DEFAULT	DESCRIPTION
Input Selector	5:4	RXINSEL[1:0]	00	S/PDIF Receiver input mux select. Note that the general purpose inputs must be configured using GPIOxOP to be either CMOS or comparator inputs if selected by RXINSEL. 00 = S/PDIF_IN1 01 = S/PDIF_IN2 (GPIO1) 10 = S/PDIF_IN3 (GPIO2) 11 = S/PDIF_IN4 (GPIO3)
	6	FILLMODE	0	Determines what SPDIF_RX should do if the validity bit indicates invalid data: 0 = Data from SPDIF_RX remains static at last valid sample. 1 = Data from SPDIF_RX is output as all zeros.
	7	ALWAYSVALID	0	Used to override the recovered validity bit. 0 = Use validity bit. 1 = Ignore validity bit.
	8	ADCCLKSRC	0	ADC clock source 0 = ADCMCLK is from MCLK pin and ADCPBCLK is from PBCLK pin 1 = ADCMCLK is from GPIO1, and ADPBCLK is from GPIO2. (Note that when in this mode RXINSEL must not be set to 01 or 10.)
100001 (41h) Interface Source Select	0	RX2DAC	0	Received S/PDIF PCM data to DAC. 0 = DAC1 takes data from Primary Audio Interface. 1 = DAC1 takes data from S/PDIF receiver.
	2:1	TXSRC[1:0]	00	S/PDIF Transmitter Data Source. 00 = S/PDIF received data. 01 = ADC digital output data. 10 = Secondary Audio Interface received data 11 = DAC Audio Interface Received data.
	3	TXRXTHRU	0	Only used if TXSRC==00. Configures only the Channel Bit in the S/PDIF frame. 0 = Channel data equal to recovered channel data. 1 = Channel data taken from channel status registers.
	5:4	PAIFSRC[1:0]	01	Audio Interface output source 00 = S/PDIF received data 01 = ADC digital output data 10 = Secondary Audio Interface received data 11 = Power-down Primary Audio Interface Transmitter
	7:6	SAIFSRC[1:0]	00	Secondary Audio Interface Transmitter Data Source. 00 = S/PDIF received data. 01 = ADC digital output data. 10 = Power-down Secondary Audio Interface Transmitter 11 = Primary Audio Interface received data.
100010 (42h) S/PDIF Data/Clock Recovery	5:3	FPLL[2:0]	111	Select jitter attenuation bandwidth. 000 = Invalid 001 = 28.84Hz 010 = 14.92Hz 011 = 7.46Hz 100 = 3.73Hz 101 = 1.87Hz 110 = 0.97Hz 111 = 0.47Hz

REGISTER ADDRESS	BIT	LABEL	DEFAULT	DESCRIPTION
1000111 (47h) GPIO Control 1	3:0	GPIO1OP[3:0]	0000	0000 = INT 0001 = V - Validity 0010 = U - User Data bit 0011 = C - Channel Status Data 0100 = P - Parity bit 0101 = Non-audio (AUDIO_N PCM_N) 0110 = UNLOCK 0111 = CSUD (Channel Status Registers Updated) 1000 = Zero Flag 1 output 1001 = Zero Flag 2 output 1010 = GPIO1set as S/PDIF input (standard CMOS input buffer) 1011 = GPIO1set as S/PDIF input ('comparator' input for AC coupled consumer S/PDIF signals) 1100 = Sub Frame clock (1 = sub-frame1, 0 = sub-frame2) 1101 = Start of Block signal
	7:4	GPIO2OP[3:0]	0001	0000 = INT 0001 = V - Validity 0010 = U - User Data bit 0011 = C - Channel Status Data 0100 = P - Parity bit 0101 = Non-audio (AUDIO_N PCM_N) 0110 = UNLOCK 0111 = CSUD (Channel Status Registers Updated) 1000 = Zero Flag 1 output 1001 = Zero Flag 2 output 1010 = GPIO2set as S/PDIF input (standard CMOS input buffer) 1011 = GPIO2set as S/PDIF input ('comparator' input for AC coupled consumer S/PDIF signals) 1100 = Sub Frame clock (1 = sub-frame1, 0 = sub-frame2) 1101 = Start of Block signal
1001000 (48h) GPIO Control 2	3:0	GPIO3OP[3:0]	0010	0000 = INT 0001 = V - Validity 0010 = U - User Data bit 0011 = C - Channel Status Data 0100 = P - Parity bit 0101 = Non-audio (AUDIO_N PCM_N) 0110 = UNLOCK 0111 = CSUD (Channel Status Registers Updated) 1000 = Zero Flag 1 output 1001 = Zero Flag 2 output 1010 = GPIO3set as S/PDIF input (standard CMOS input buffer) 1011 = GPIO3set as S/PDIF input ('comparator' input for AC coupled consumer S/PDIF signals) 1100 = Sub Frame clock (1 = sub-frame1, 0 = sub-frame2) 1101 = Start of Block signal

REGISTER ADDRESS	BIT	LABEL	DEFAULT	DESCRIPTION
	7:4	GPOMODEOP [3:0]	1010	0000 = INT 0001 = V - Validity 0010 = U - User Data bit 0011 = C - Channel Status Data 0100 = P - Parity bit 0101 = Non-audio (AUDIO_N PCM_N) 0110 = UNLOCK 0111 = CSUD (Channel Status Registers Updated) 1000 = Zero Flag 1 output 1001 = Zero Flag 2 output 1010 = not used 1011 = not used 1100 = Sub Frame clock (1 = sub-frame1, 0 = sub-frame2) 1101 = Start of Block signal
1001001 (49h) S/PDIF Receiver Error Mask	7:0	MASK[7:0]	0000000	When a lag is masked, it does not update the Error Register or contribute to the interrupt pulse. 0 = unmask, 1 = mask. MASK[0] = mask control for UNLOCK MASK[1] = mask control for VALIDITY MASK[2] = mask control for PARITYERR MASK[3] = mask control for BIP MASK[4] = mask control for AUDIO_N MASK[5] = mask control for PCM_N MASK[6] = mask control for CPY_N MASK[7] = mask control for SPDIF_MODE
1001010 (4Ah) Read-back Control	4	READEN3	0	3-Wire Read-back mode enable. 0 = 3-Wire read-back mode disabled 1 = 3-Wire read-back mode enabled
	5	READEN2	0	2-Wire Read-back mode enable. 0 = 2-Wire read-back mode disabled 1 = 2-Wire read-back mode enabled
1001011 (4Bh) S/PDIF Receiver Error Register (read-only)	0	UNLOCK		PLL Unlock signal. 0 = PLL is locked to incoming S/PDIF stream. 1 = PLL is not locked to the incoming S/PDIF stream.
	1	VALIDITY		V bit from S/PDIF input stream. 0 = Data word is valid. 1 = Data word is not valid.
	2	PARITYERR		Even Parity check. 0 = No Parity errors detected. 1 = Parity error detected.
	3	BIP		Biphase coding of S/PDIF input stream. 0 = Biphase Coding is correct. 1 = Biphase Coding error detected.
	4	AUDIO_N		Received Channel status bit 1 has changed. 0 = Normal running. 1 = Change on AUDIO_N.
	5	PCM_N		PCM_N bit has changed 0 = Normal running. 1 = Change on PCM_N.
	6	CPY_N		Received Channel status bit 2 has changed. 0 = Normal running. 1 = Change on CPY_N.

REGISTER ADDRESS	BIT	LABEL	DEFAULT	DESCRIPTION	
	7	SPDIF_MODE		S/PDIF mode change. 0: Normal running 1: Change in S/PDIF frequency mode detected.	
1001100 (4Ch) S/PDIF Receiver Channel Status Register 1 (read-only)	0	CON/PRO		Recovered S/PDIF Channel status bit 0. 0 = Consumer Mode 1 = Professional Mode The WM8777 is a consumer mode device. Detection of professional mode may give erroneous behavior.	
	1	AUDIO_N		Recovered S/PDIF Channel status bit 1. 0 = Data word represents audio PCM samples. 1 = Data word does not represent audio PCM samples.	
	2	CPY_N		Recovered S/PDIF Channel status bit 2. 0 = Copyright is asserted for this data. 1 = Copyright is not asserted for this data.	
	3	DEEMPH		Recovered S/PDIF Channel status bit 3. 0 = Recovered S/PDIF data has no pre-emphasis. 1 = Recovered S/PDIF data has pre-emphasis.	
	5:4	Reserved		Recovered S/PDIF Channel status bits[5:4]. Reserved for additional de-emphasis modes.	
	7:6	CHSTMODE[1:0]		Recovered S/PDIF Channel status bits[7:6]. 00 = Only valid mode for consumer applications. All other modes reserved.	
1001101 (4Dh) S/PDIF Receiver Channel Status Register 2 (read-only)	7:0	CATCODE[7:0]		Recovered S/PDIF Channel status bits[15:8] - Category Code. Refer to S/PDIF specification for details. 00h indicates "general" mode.	
1001110 (4Eh) S/PDIF Receiver Channel Status Register 3 (read-only)	3:0	SRCNUM[3:0]		Recovered S/PDIF Channel status bits[19:16] - Indicates number of S/PDIF source.	
	7:4	CHNUM1[3:0]		Recovered S/PDIF Channel status bits[23:20] - Channel number for channel 1. 0000 = Take no account of channel number (channel 1 defaults to left DAC) 0001 = channel 1 to left channel 0010 = channel 1 to right channel	
1001111 (4Fh) S/PDIF Receiver Channel Status Register 4 (read-only)	3:0	FREQ[3:0]		Recovered S/PDIF Channel status bits[27:24] - Sampling Frequency. See S/PDIF specification for details. 0001 = Sampling Frequency not indicated.	
	5:4	CLKACU[1:0]		Recovered S/PDIF Channel status bits[29:28] - Clock Accuracy of received clock. 00 = Level II 01 = Level I 10 = Level III 11 = Interface frame rate not matched to sampling frequency.	
1010000 (50h) S/PDIF Receiver Channel Status Register 5 (read-only)	0	MAXPAIFRX_WL		Recovered S/PDIF Channel status bit[32] - Maximum Audio sample word length 0 = 20 bits 1 = 24 bits	
	3:1	RXPAIFRX_WL [2:0]		Recovered S/PDIF Channel status bits[35:33] - Audio Sample Word Length	
			RXPAIFRX_WL	MAXPAIFRX_WL= =1	MAXPAIFRX_WL= =0
			001	20 bits	16 bits
			010	22 bits	18 bits
100	23 bits	19 bits			

REGISTER ADDRESS	BIT	LABEL	DEFAULT	DESCRIPTION		
				101	24 bits	20 bits
				110	21 bits	17 bits
				All other combinations are reserved and may give erroneous operation.		
	7:4	ORGSAMP[3:0]		Recovered S/PDIF Channel status bits[39:36] - Original Sampling Frequency. See S/PDIF specification for details. 0000 = original sampling frequency not indicated		
1010001 (51h) S/PDIF Status (read- only)	0	AUDIO_N		Received Channel status bit 1 0 = Data word represents audio PCM samples. 1 = Data word does not represent audio PCM samples.		
	1	PCM_N		Detects non-audio data from a 96-bit sync code, as defined in IEC-61937. 0 = Sync code not detected. 1 = Sync code detected – received data is not audio PCM.		
	2	CPY_N		Recovered S/PDIF Channel status bit 2. 0 = Copyright is asserted for this data. 1 = Copyright is not asserted for this data. Note this signal is inverted and will cause an interrupt on logic 0.		
	4:3	SPDIF_MODE		S/PDIF frequency mode. 00: Not supported 01: 88-96KHz 10: 44-48KHz 11: 32KHz		
1111111 (7Fh) Software reset	8:0	RESET		Writing any value to this register will apply a reset to the device registers.		

Table 82 Register Map Description

DIGITAL FILTER CHARACTERISTICS

PARAMETER	TEST CONDITIONS	MIN	TYP	MAX	UNIT
ADC Filter					
Passband	± 0.01 dB	0		0.4535fs	
	-6dB		0.5fs		
Passband ripple				± 0.01	dB
Stopband		0.5465fs			
Stopband Attenuation	$f > 0.5465$ fs	-65			dB
Group Delay			22		fs
DAC Filter					
Passband	± 0.05 dB			0.444fs	
	-3dB		0.487fs		
Passband ripple				± 0.05	dB
Stopband		0.555fs			
Stopband Attenuation	$f > 0.555$ fs	-60			dB
Group Delay			16		fs

Table 83 Digital Filter Characteristics

DAC FILTER RESPONSES

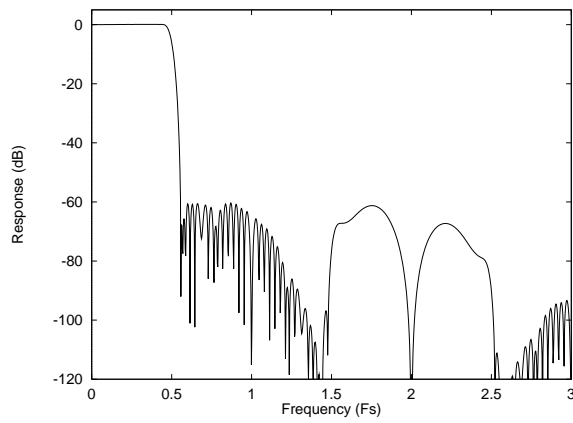

Figure 32 DAC Digital Filter Frequency Response – 44.1, 48 and 96kHz

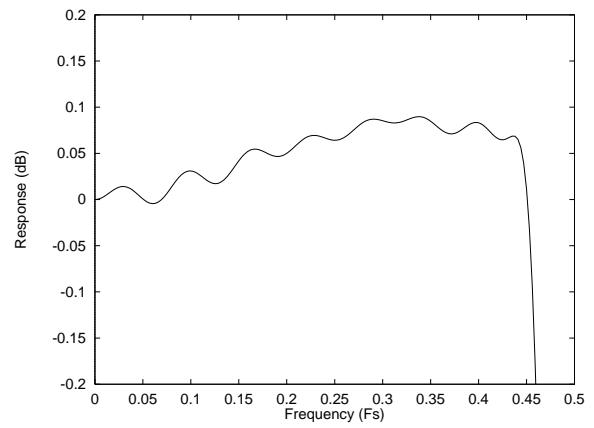

Figure 33 DAC Digital Filter Ripple – 44.1, 48 and 96kHz

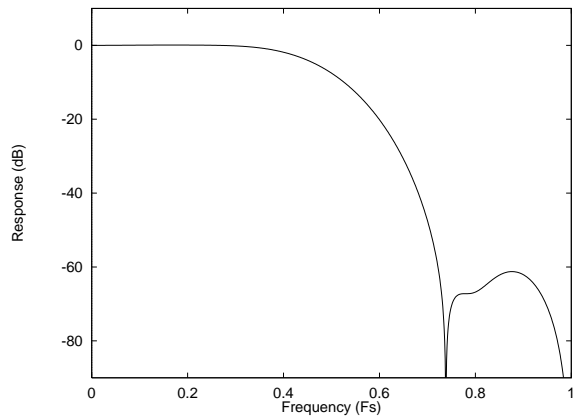

Figure 34 DAC Digital Filter Frequency Response (with DACOSR=1) – 192kHz

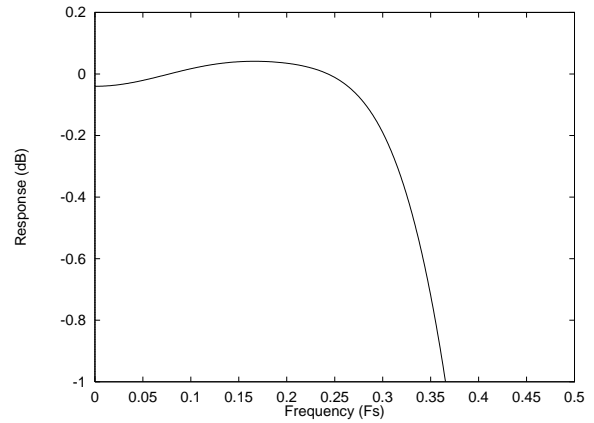

Figure 35 DAC Digital filter Ripple (with DACOSR=1) - 192kHz

ADC FILTER RESPONSES

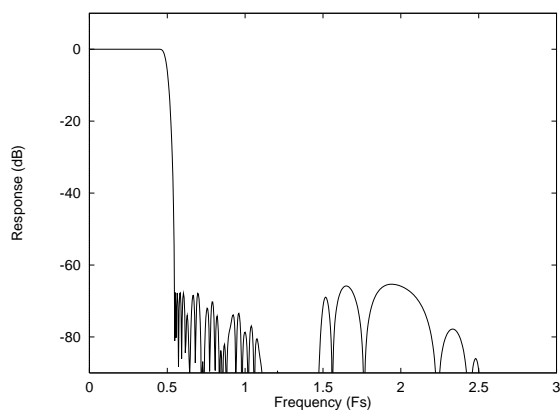

Figure 36 ADC Digital Filter Frequency Response

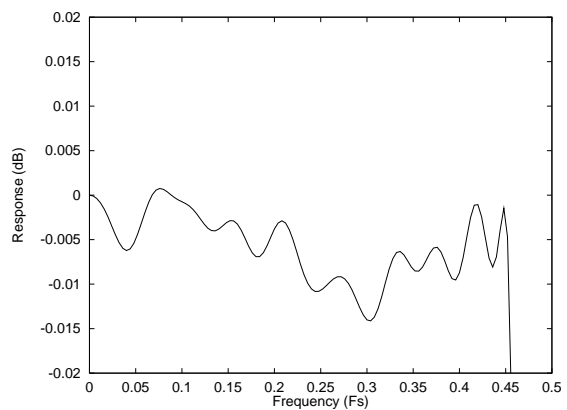

Figure 37 ADC Digital Filter Ripple

ADC HIGH PASS FILTER

The WM8777 has a selectable digital highpass filter to remove DC offsets. The filter response is characterised by the following polynomial.

$$H(z) = \frac{1 - z^{-1}}{1 - 0.9995z^{-1}}$$

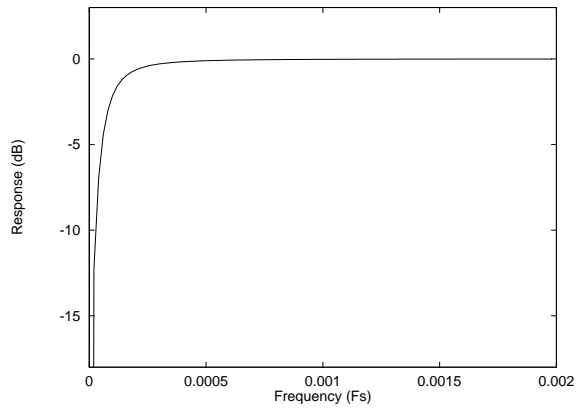

Figure 38 ADC Highpass Filter Response

DIGITAL DE-EMPHASIS CHARACTERISTICS

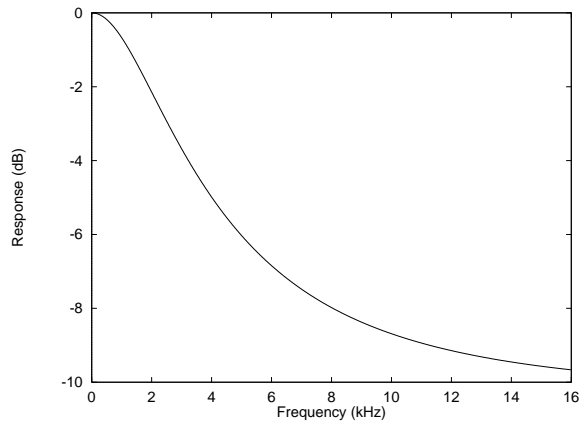

Figure 39 De-Emphasis Frequency Response (32kHz)

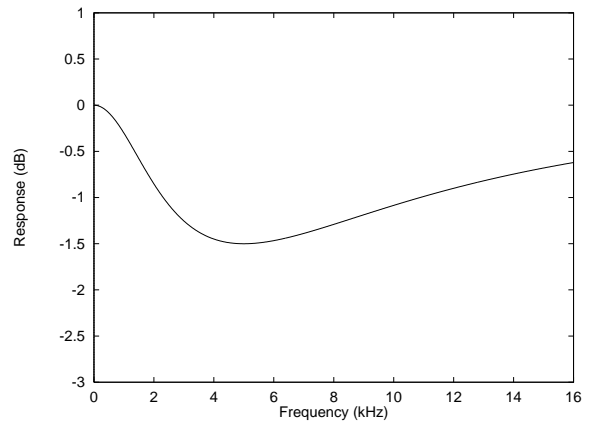

Figure 40 De-Emphasis Error (32kHz)

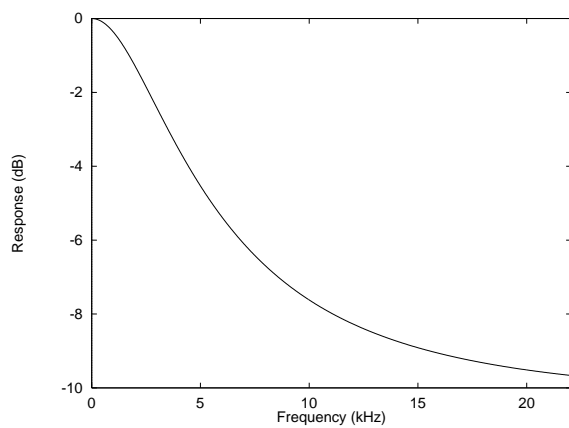

Figure 41 De-Emphasis Frequency Response (44.1kHz)

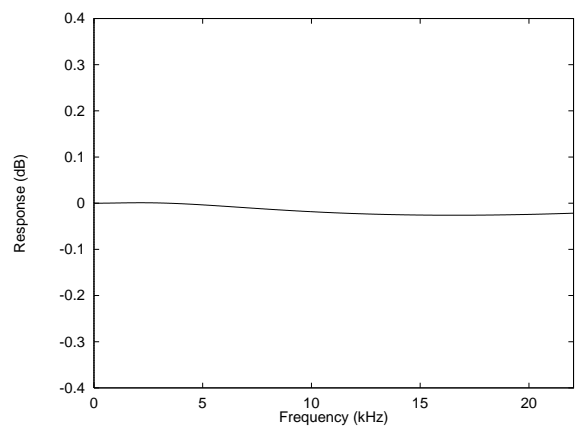

Figure 42 De-Emphasis Error (44.1kHz)

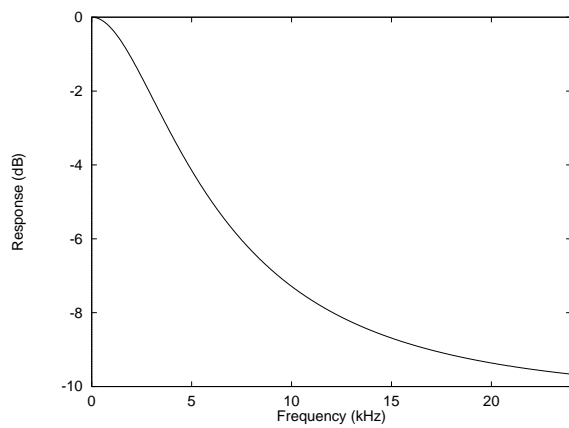

Figure 43 De-Emphasis Frequency Response (48kHz)

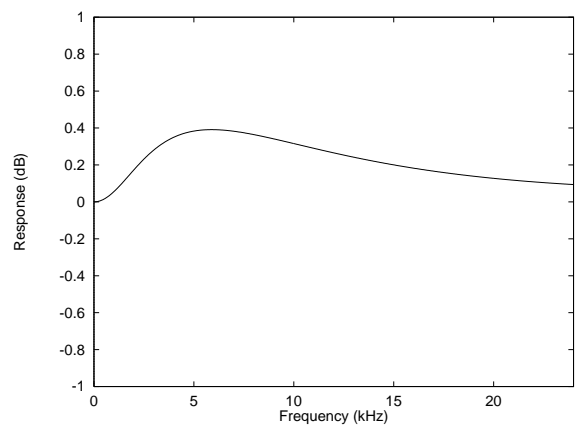

Figure 44 De-Emphasis Error (48kHz)

APPLICATIONS INFORMATION

EXTERNAL ANALOGUE INPUT CIRCUIT CONFIGURATION

In order to allow the use of 2V rms and larger inputs to the ADC and AUX inputs, a structure is used that uses external resistors to drop these larger voltages. This also increases the robustness of the circuit to external abuse such as ESD pulse.

Figure 45 shows the ADC input multiplexor circuit with external components allowing 2Vrms inputs to be applied.

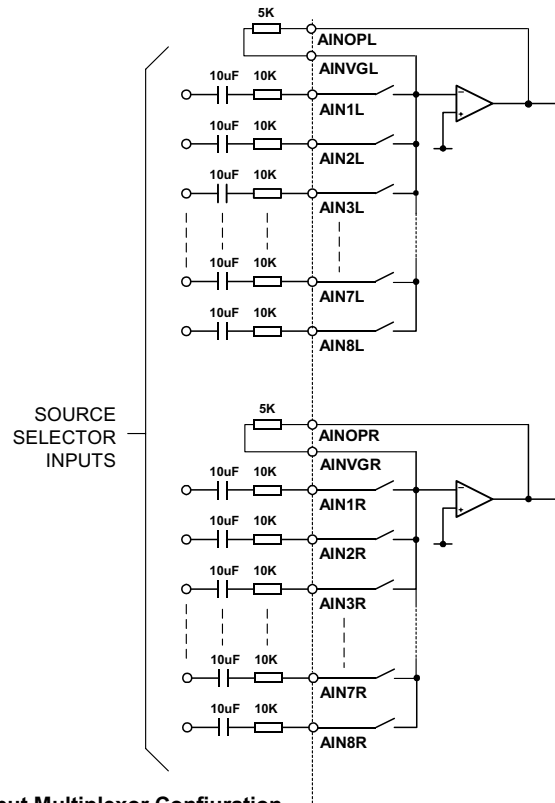

Figure 45 ADC Input Multiplexor Configuration

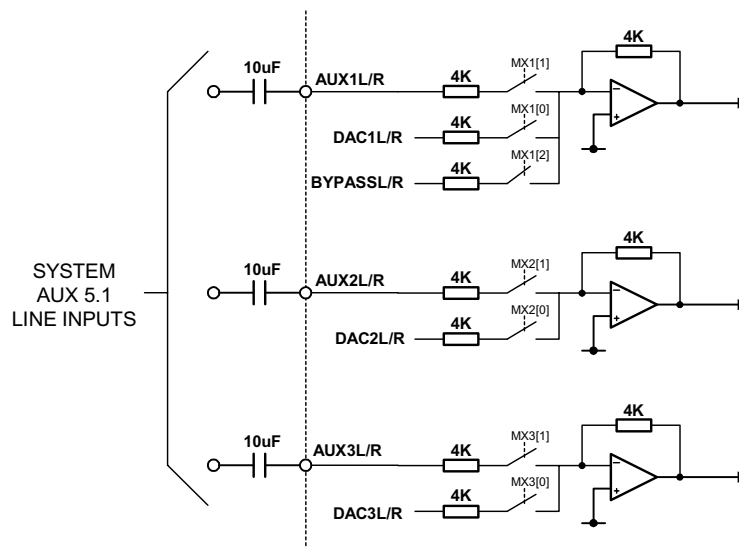
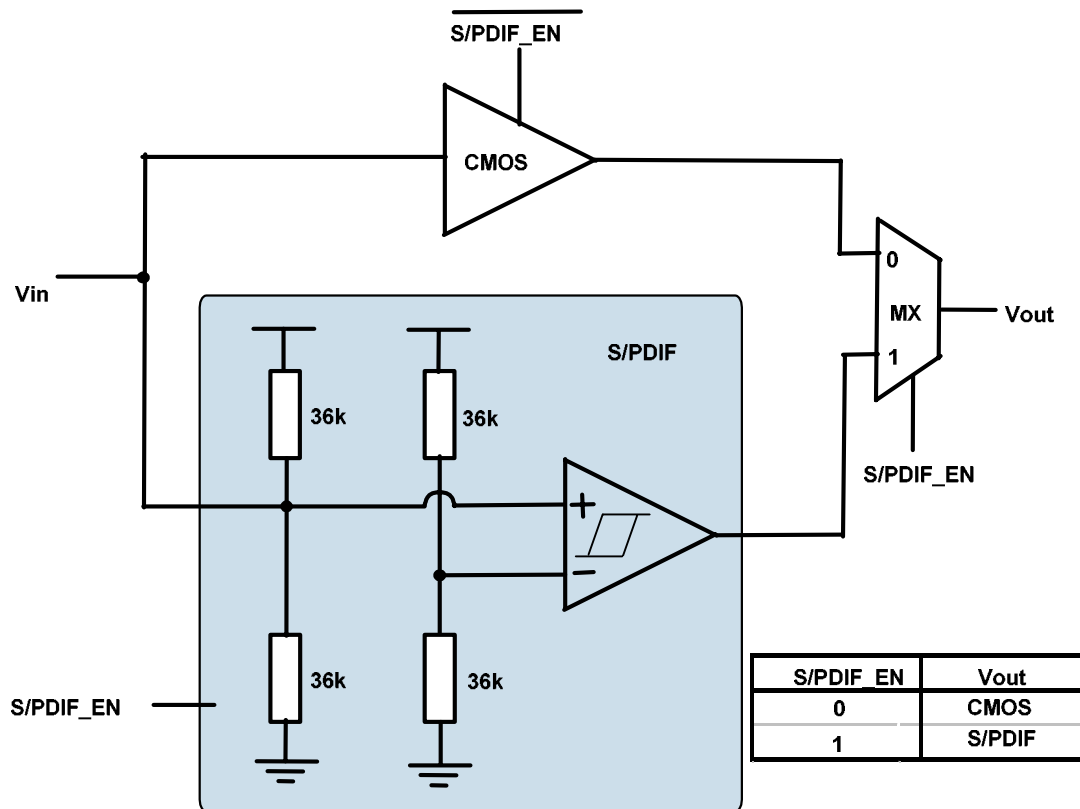

Figure 46 Shows the 5.1Channel Input Multiplexor Configuration

EXTERNAL S/PDIF INPUT CIRCUIT CONFIGURATION

The SPIN, GPIO1, GPIO2, and GPIO3 pads can be configured to accept either CMOS or S/PDIF input signals. In S/PDIF mode an A.C. coupled input signal is applied to Vin. A hysteresis comparator buffers this signal and converts it to CMOS to drive on-chip. In CMOS mode the S/PDIF circuit is disabled and the signal is buffered using standard CMOS logic.



To allow an S/PDIF signal to be received correctly the incoming signal must be A.C. coupled. The recommended off-chip input configuration for this is shown below:

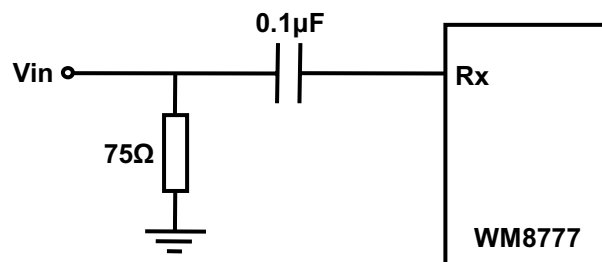

RECOMMENDED ANALOGUE OUTPUT EXTERNAL COMPONENTS

It may be that a lowpass filter is required to be applied to the output from each DAC channel for Hi Fi applications. Typically a second order filter is suitable and provides sufficient attenuation of high frequency components (the unique low order, high bit count multi-bit sigma delta DAC structure used in WM8777 produces much less high frequency output noise than competitors devices). This filter is typically also used to provide the 2x gain needed to provide the standard 2Vrms output level from most consumer equipment. Figure 47 shows a suitable post DAC filter circuit, with 2x gain. Alternative inverting filter architectures might also be used with as good results.

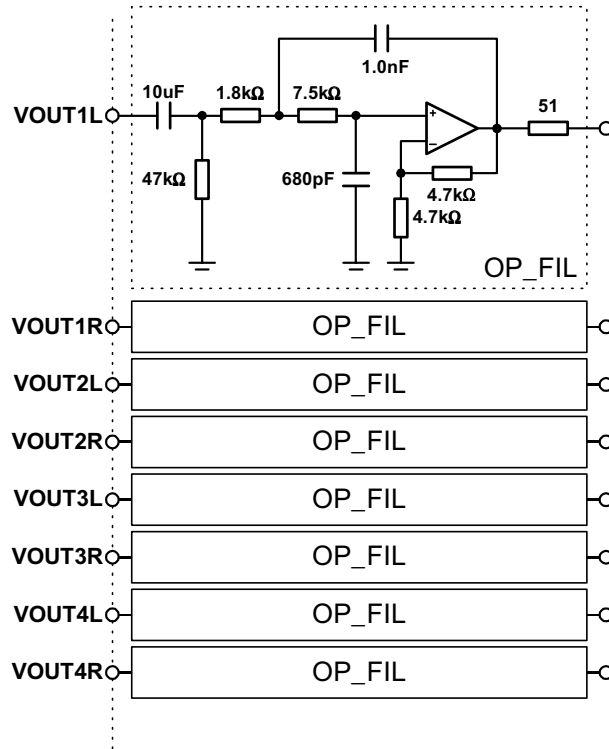
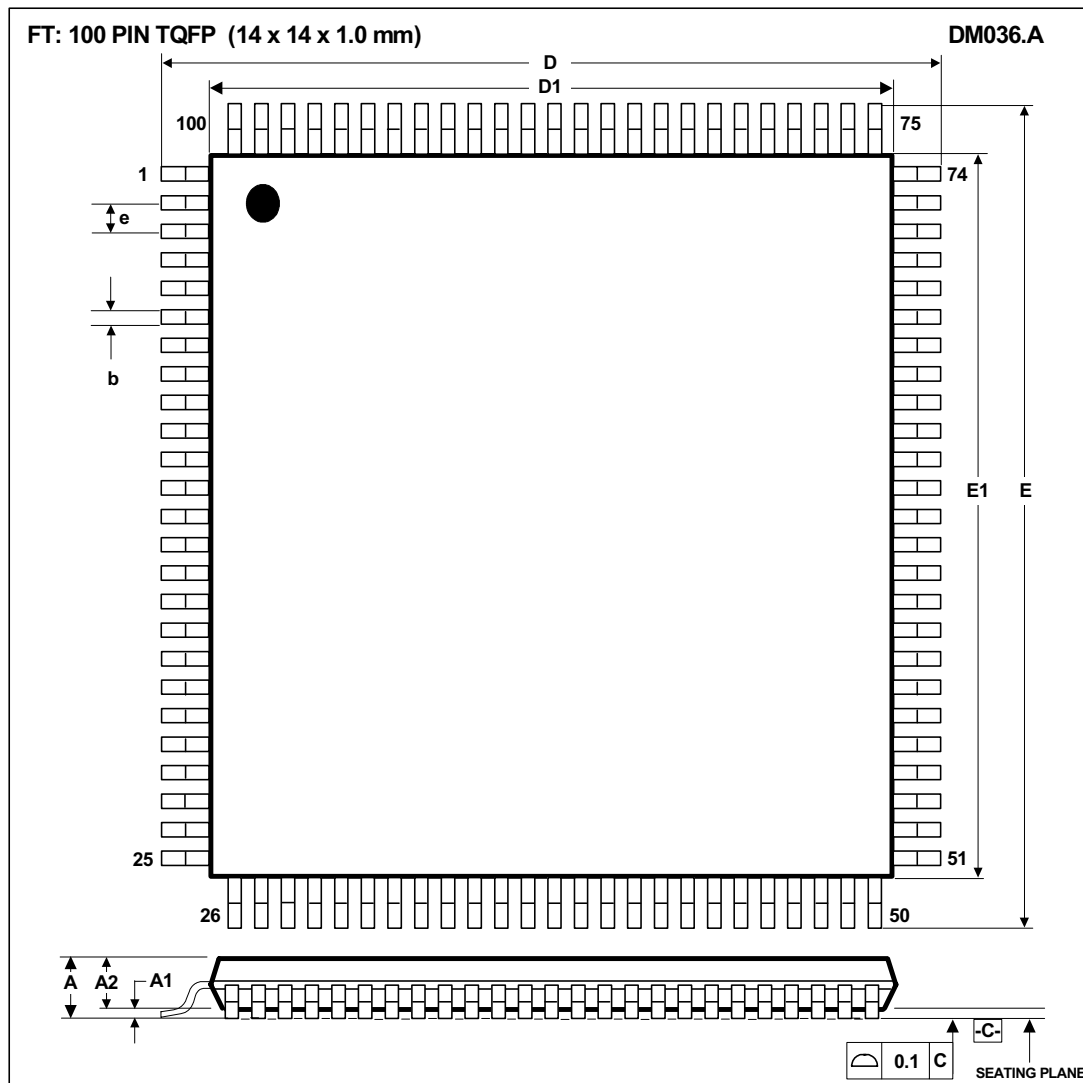
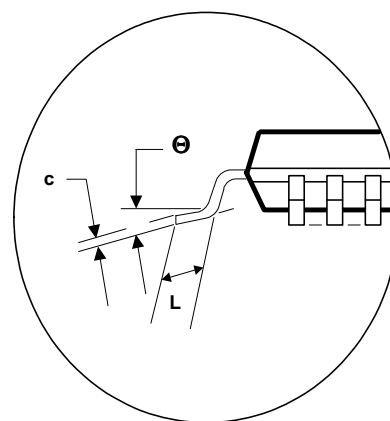

Figure 47 Recommended Post DAC Filter Circuit

PACKAGE DIMENSIONS



Symbols	Dimensions (mm)		
	MIN	NOM	MAX
A	----	----	1.60
A ₁	0.05	----	0.15
A ₂	1.35	1.40	1.45
b	0.17	0.22	0.27
c	----	----	0.17
D	15.80	16.00	16.20
D ₁	13.95	14.00	14.05
E	15.80	16.00	16.20
E ₁	13.95	14.00	11.05
e		0.50 BSC	
L	0.50	0.60	0.75
Θ	0°	3.5°	7°
Tolerances of Form and Position			
ccc	0.08		
REF:	JEDEC.95, MS-026		



- NOTES:
- A. ALL LINEAR DIMENSIONS ARE IN MILLIMETERS.
 - B. THIS DRAWING IS SUBJECT TO CHANGE WITHOUT NOTICE.
 - C. BODY DIMENSIONS DO NOT INCLUDE MOLD FLASH OR PROTRUSION, NOT TO EXCEED 0.25MM.
 - D. MEETS JEDEC.95 MS-026, VARIATION = ABA. REFER TO THIS SPECIFICATION FOR FURTHER DETAILS.

IMPORTANT NOTICE

Wolfson Microelectronics plc (WM) reserve the right to make changes to their products or to discontinue any product or service without notice, and advise customers to obtain the latest version of relevant information to verify, before placing orders, that information being relied on is current. All products are sold subject to the WM terms and conditions of sale supplied at the time of order acknowledgement, including those pertaining to warranty, patent infringement, and limitation of liability.

WM warrants performance of its products to the specifications applicable at the time of sale in accordance with WM's standard warranty. Testing and other quality control techniques are utilised to the extent WM deems necessary to support this warranty. Specific testing of all parameters of each device is not necessarily performed, except those mandated by government requirements.

In order to minimise risks associated with customer applications, adequate design and operating safeguards must be used by the customer to minimise inherent or procedural hazards. Wolfson products are not authorised for use as critical components in life support devices or systems without the express written approval of an officer of the company. Life support devices or systems are devices or systems that are intended for surgical implant into the body, or support or sustain life, and whose failure to perform when properly used in accordance with instructions for use provided, can be reasonably expected to result in a significant injury to the user. A critical component is any component of a life support device or system whose failure to perform can be reasonably expected to cause the failure of the life support device or system, or to affect its safety or effectiveness.

WM assumes no liability for applications assistance or customer product design. WM does not warrant or represent that any license, either express or implied, is granted under any patent right, copyright, mask work right, or other intellectual property right of WM covering or relating to any combination, machine, or process in which such products or services might be or are used. WM's publication of information regarding any third party's products or services does not constitute WM's approval, license, warranty or endorsement thereof.

Reproduction of information from the WM web site or datasheets is permissible only if reproduction is without alteration and is accompanied by all associated warranties, conditions, limitations and notices. Representation or reproduction of this information with alteration voids all warranties provided for an associated WM product or service, is an unfair and deceptive business practice, and WM is not responsible nor liable for any such use.

Resale of WM's products or services with statements different from or beyond the parameters stated by WM for that product or service voids all express and any implied warranties for the associated WM product or service, is an unfair and deceptive business practice, and WM is not responsible nor liable for any such use.

ADDRESS:

Wolfson Microelectronics plc
Westfield House
26 Westfield Road
Edinburgh
EH11 2QB
United Kingdom

Tel :: +44 (0)131 272 7000

Fax :: +44 (0)131 272 7001

Email :: sales@wolfsonmicro.com