

16K

X20C17

2K x 8 Bit

High Speed AUTOSTORE™ NOVRAM

FEATURES

- 24-Pin Standard SRAM DIP Pinout
- Fast Access Time: 35ns, 45ns, 55ns
- High Reliability
 - Endurance: 1,000,000 Nonvolatile Store Operations
 - Retention: 100 Years Minimum
- AUTOSTORE™ NOVRAM
 - Automatically Stores SRAM Data Into the E²PROM Array When V_{CC} Low Threshold is Detected
 - E²PROM Data Automatically Recalled Into RAM Upon Power-up
- Low Power CMOS
 - Standby: 250µA
- Infinite E²PROM Array Recall, and RAM Read and Write Cycles

DESCRIPTION

The Xicor X20C17 is a 2Kx8 NOVRAM featuring a high-speed static RAM overlaid bit-for-bit with a nonvolatile electrically erasable PROM (E²PROM) and the AUTOSTORE feature which automatically saves the RAM contents to E²PROM at power-down. The X20C17 is fabricated with advanced CMOS floating gate technology to achieve high speed with low power and wide power-supply margin. The X20C17 features a compatible JEDEC approved byte-wide memory pinout for industry standard SRAMs.

The NOVRAM design allows data to be easily transferred from RAM to E²PROM (store) and E²PROM to RAM (recall). The store operation is completed in 2.5ms or less. An automatic array recall operation reloads the contents of the E²PROM into RAM upon power-up.

Xicor NOVRAMS are designed for unlimited write operations to RAM, either from the host or recalls from E²PROM, and a minimum 1,000,000 store operations to the E²PROM. Data retention is specified to be greater than 100 years.

PIN CONFIGURATION

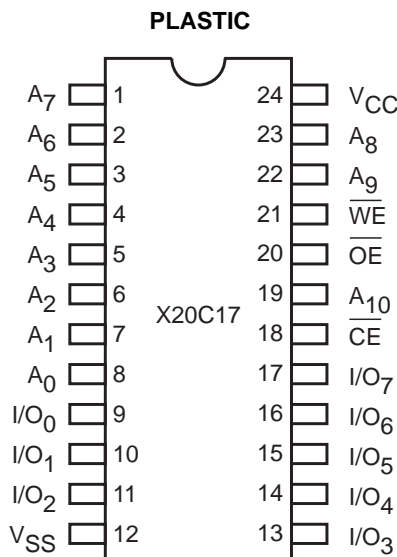

2015 ILL F02.1

AUTOSTORE™ NOVRAM is a trademark of Xicor, Inc.

X20C17

PIN DESCRIPTIONS

Addresses (A_0 – A_{10})

The Address inputs select an 8-bit memory location during a read or write operation.

Chip Enable (\overline{CE})

The Chip Enable input must be LOW to enable all read/write operations. When \overline{CE} is HIGH, power consumption is reduced.

Output Enable (\overline{OE})

The Output Enable input controls the data output buffers and is used to initiate read and recall operations. Output Enable LOW disables a store operation regardless of the state of \overline{CE} , \overline{WE} .

Data In/Data Out (I/O_0 – I/O_7)

Data is written to or read from the X20C17 through the I/O pins. The I/O pins are placed in the high impedance state when either \overline{CE} or \overline{OE} is HIGH.

Write Enable (\overline{WE})

The Write Enable input controls the writing of data to the static RAM.

PIN NAMES

Symbol	Description
A_0 – A_{10}	Address Inputs
I/O_0 – I/O_7	Data Input/Output
\overline{WE}	Write Enable
\overline{CE}	Chip Enable
\overline{OE}	Output Enable
V_{CC}	+5V
V_{SS}	Ground

2015 PGM T01

FUNCTIONAL DIAGRAM

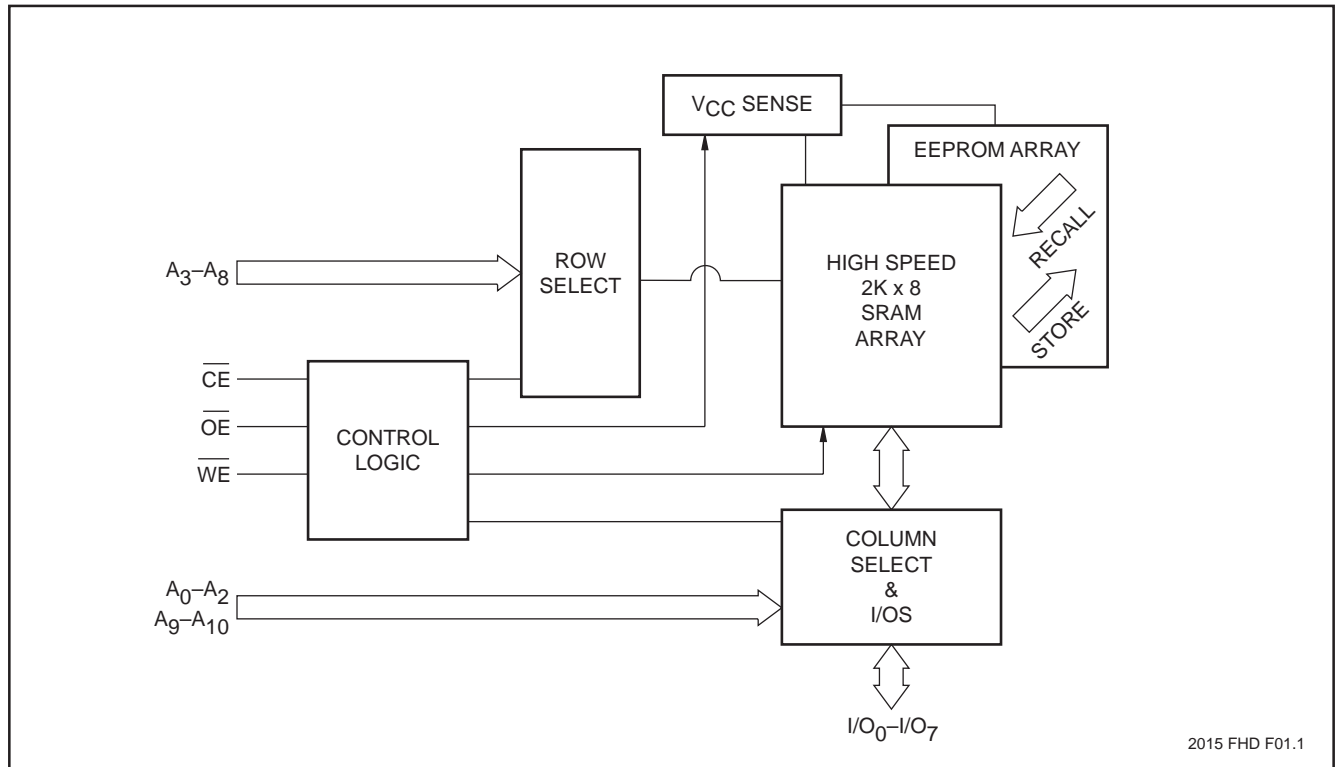

2015 FHD F01.1

X20C17

DEVICE OPERATION

The \overline{CE} , \overline{OE} , and \overline{WE} inputs control the X20C17 operation. The X20C17 byte-wide NOVRAM uses a 2-line control architecture to eliminate bus contention in a system environment. The I/O bus will be in a high impedance state when either \overline{OE} or \overline{CE} is HIGH.

RAM Operations

RAM read and write operations are performed as they would be with any static RAM. A read operation requires \overline{CE} and \overline{OE} to be LOW. A write operation requires \overline{CE} and \overline{WE} to be LOW. There is no limit to the number of read or write operations performed to the RAM portion of the X20C17.

Memory Transfer Operations

There are two memory transfer operations: a recall operation whereby the data stored in the E²PROM array is transferred to the RAM array; and a store operation which causes the entire contents of the RAM array to be stored in the E²PROM array.

Recall operations are performed automatically upon power-up.

Store operations are performed automatically upon power-down. The store operation take a maximum of 2.5ms.





Write Protection

The X20C17 supports two methods of protecting the nonvolatile data.

- If after power-up no RAM write operations have occurred, no AUTOSTORE operation can be initiated.
- V_{CC} Sense – All functions are inhibited when V_{CC} is $\leq 3V$ typical.

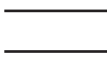
SYMBOL TABLE

The following symbol table provides a key to understanding the conventions used in the device timing diagrams. The diagrams should be used in conjunction with the device timing specifications to determine actual device operation and performance, as well as device suitability for user's application.

WAVEFORM	INPUTS	OUTPUTS
	Must be steady	Will be steady
	May change from LOW to HIGH	Will change from LOW to HIGH
	May change from HIGH to LOW	Will change from HIGH to LOW
	Don't Care: Changes Allowed	Changing: State Not Known
	N/A	Center Line is High Impedance

X20C17

ABSOLUTE MAXIMUM RATINGS*

Temperature under Bias	-65°C to +135°C
Storage Temperature	-65°C to +150°C
Voltage on any Pin with Respect to V _{SS}	-1V to +7V
D.C. Output Current	10mA
Lead Temperature (Soldering, 10 seconds)	300°C

*COMMENT

Stresses above those listed under “Absolute Maximum Ratings” may cause permanent damage to the device. This is a stress rating only and the functional operation of the device at these or any conditions other than those indicated in the operational sections of this specification is not implied. Exposure to absolute maximum rating conditions for extended periods may affect device reliability.

RECOMMENDED OPERATING CONDITIONS

Temperature	Min.	Max.
Commercial	0°C	+70°C
Industrial	-40°C	+85°C
Military	-55°C	+125°C

2015 PGM T02.1

Supply Voltage	Limits
X20C17	4.5V to 5.25V

2015 PGM T03.1

D.C. OPERATING CHARACTERISTICS (Over recommended operating conditions unless otherwise specified.)

Symbol	Parameter	Limits			Test Conditions
		Min.	Max.	Units	
I _{CC1}	V _{CC} Current (Active)		100	mA	$\overline{WE} = V_{IH}, \overline{CE} = \overline{OE} = V_{IL}$ Address Inputs = 0.4V/2.4V Levels @ f = 20MHz, All I/Os = Open
I _{CC2} ⁽²⁾	V _{CC} Current During AUTOSTORE		2.5	mA	All I/Os = Open
I _{SB1}	V _{CC} Standby Current (TTL Input)		10	mA	All Inputs = V _{IH} , All I/Os = Open
I _{SB2}	V _{CC} Standby Current (CMOS Input)		250	μA	All Inputs = V _{CC} - 0.3V All I/Os = Open
I _{LI}	Input Leakage Current		10	μA	V _{IN} = V _{SS} to V _{CC}
I _{LO}	Output Leakage Current		10	μA	V _{OUT} = V _{SS} to V _{CC} , $\overline{CE} = V_{IH}$
V _{IL} ⁽¹⁾	Input LOW Voltage	-1	0.8	V	
V _{IH} ⁽¹⁾	Input HIGH Voltage	2	V _{CC} + 1	V	
V _{OL}	Output LOW Voltage		0.4	V	I _{OL} = 4mA
V _{OH}	Output HIGH Voltage	2.4		V	I _{OH} = -4mA

2015 PGM T04.3

POWER-UP TIMING

Symbol	Parameter	Max.	Units
t _{PUR} ⁽²⁾	Power-Up to RAM Operation	100	μs
t _{PUW} ⁽²⁾	Power-Up to Nonvolatile Operation	5	ms

2015 PGM T05

CAPACITANCE T_A = +25°C, f = 1MHz, V_{CC} = 5V.

Symbol	Test	Max.	Units	Conditions
C _{I/O} ⁽²⁾	Input/Output Capacitance	10	pF	V _{I/O} = 0V
C _{IN} ⁽²⁾	Input Capacitance	6	pF	V _{IN} = 0V

2015 PGM T06.2

Notes: (1) V_{IL} min. and V_{IH} max. are for reference only and are not tested.
(2) This parameter is periodically sampled and not 100% tested.

X20C17

ENDURANCE AND DATA RETENTION

Parameter	Min.	Units
Endurance	100,000	Data Changes Per Bit
Store Cycles	1,000,000	Store Cycles
Data Retention	100	Years

2015 PGM T07.1

MODE SELECTION

\overline{CE}	\overline{WE}	\overline{OE}	Mode	I/O	Power
H	X	X	Not Selected	Output High Z	Standby
L	H	L	Read RAM	Output Data	Active
L	L	H	Write "1" RAM	Input Data High	Active
L	L	H	Write "0" RAM	Input Data Low	Active
L	L	L	Not Allowed	Output High Z	Active
L	H	H	No Operation	Output High Z	Active

2015 PGM T09

EQUIVALENT A.C. LOAD CIRCUIT

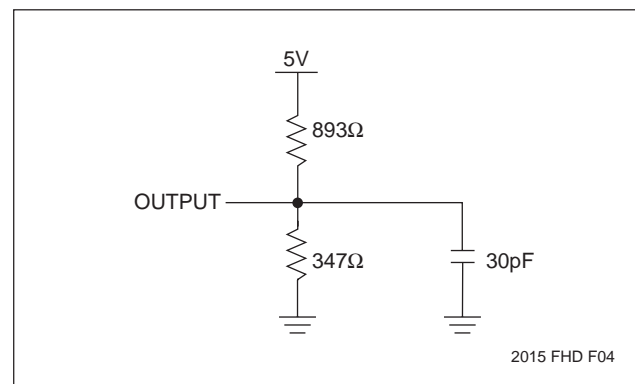

2015 FHD F04

A.C. CONDITIONS OF TEST

Input Pulse Levels	0V to 3V
Input Rise and Fall Times	5ns
Input and Output Timing Levels	1.5V

2015 PGM T08.1

X20C17

A.C. CHARACTERISTICS (Over the recommended operating conditions unless otherwise specified)

Read Cycle Limits

Symbol	Parameter	X20C17-35 -40°C to +85°C		X20C17-45		X20C17-55		Units
		Min.	Max.	Min.	Max.	Min.	Max.	
t_{RC}	Read Cycle Time	35		45		55		ns
t_{CE}	Chip Enable Access Time		35		45		55	ns
t_{AA}	Address Access Time		35		45		55	ns
t_{OE}	Output Enable Access Time		20		25		30	ns
$t_{LZ}^{(3)}$	Chip Enable to Output in Low Z	0		0		0		ns
$t_{OLZ}^{(3)}$	Output Enable to Output in Low Z	0		0		0		ns
$t_{HZ}^{(3)}$	Chip Disable to Output in High Z	0	15	0	20	0	25	ns
$t_{OHZ}^{(3)}$	Output Disable to Output in High Z	0	15	0	20	0	25	ns
t_{OH}	Output Hold From Address Change	0		0		0		ns

2015 PGM T10

Read Cycle

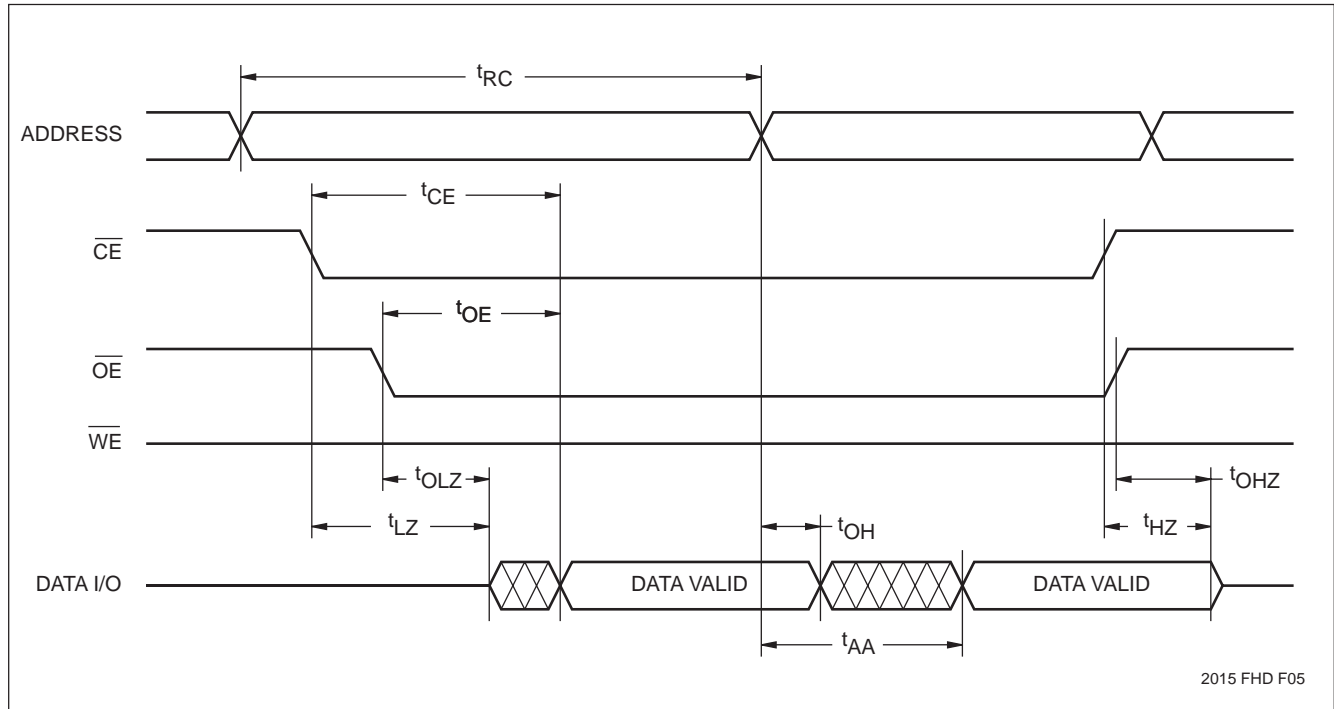

2015 FHD F05

Note: (3) t_{LZ} min., t_{HZ} , t_{OLZ} min., and t_{OHZ} are periodically sampled and not 100% tested. t_{HZ} max. and t_{OHZ} max. are measured, with $C_L = 5pF$, from the point when \overline{CE} or \overline{OE} return HIGH (whichever occurs first) to the time when the Outputs are no longer driven.

X20C17

Write Cycle Limits

Symbol	Parameter	X20C17-35		X20C17-45		X20C17-55		Units
		Min.	Max.	Min.	Max.	Min.	Max.	
t_{WC}	Write Cycle Time	35		45		55		ns
t_{CW}	Chip Enable to End of Write Input	30		35		40		ns
t_{AS}	Address Setup Time	0		0		0		ns
t_{WP}	Write Pulse Width	30		35		40		ns
t_{WR}	Write Recovery Time	0		0		0		ns
t_{DW}	Data Setup to End of Write	15		20		25		ns
t_{DH}	Data Hold Time	3		3		3		ns
$t_{OE\overline{H}}$	\overline{OE} High Hold Time	0		0		0		ns
t_{OES}	\overline{OE} High Setup Time	0		0		0		ns
$t_{OZ}^{(4)}$	Output Enable to Output in High Z		15		20		25	ns

2015 PGM T11

Write Cycle

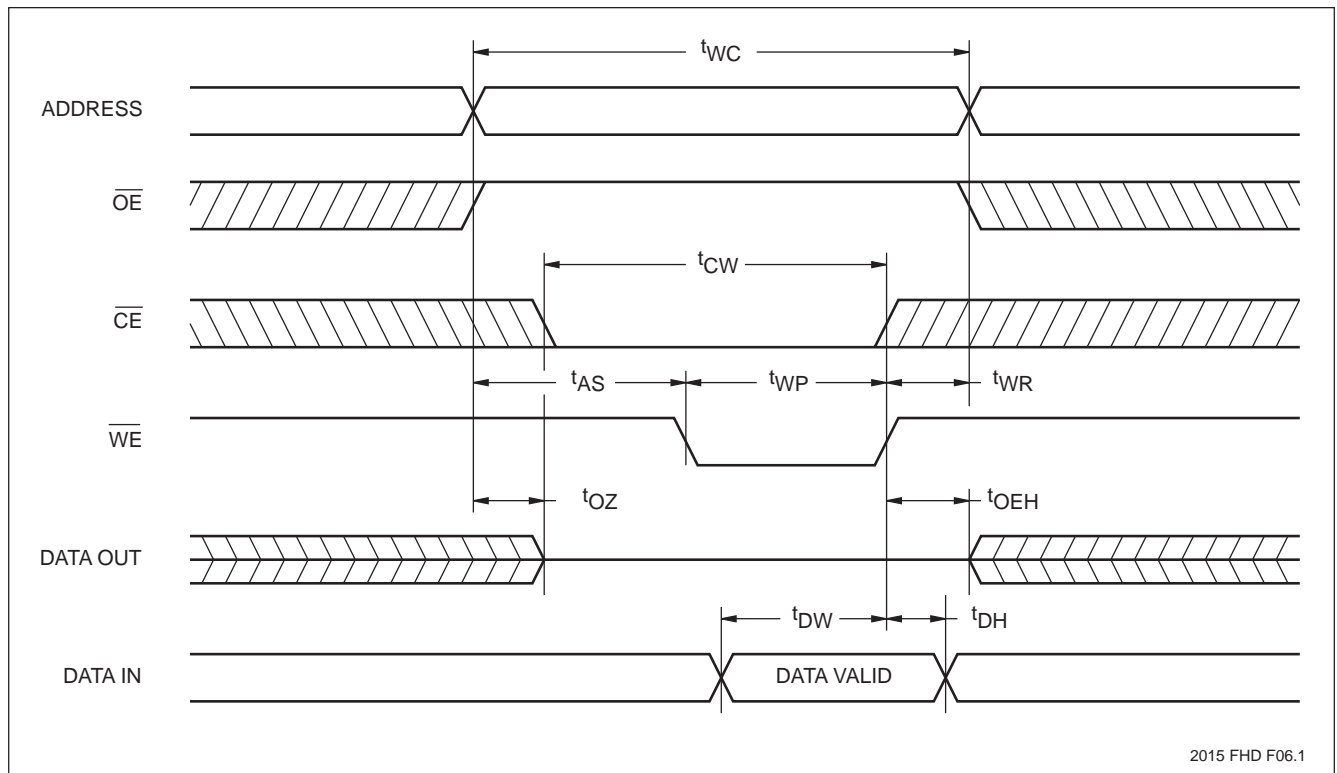

2015 FHD F06.1

Note: (4) t_{OW} , t_{OZ} are periodically sampled and not 100% tested.

X20C17

AUTOSTORE Feature

The AUTOSTORE feature automatically saves the contents of the X20C17's static RAM to the on-board bit-for-bit shadow E²PROM at power-down. This circuitry insures that no data is lost during accidental power-downs or general system crashes, and is ideal for microprocessor caching systems, embedded software systems, and general system back-up memory.

The X20C17 automatically initiates a nonvolatile store cycle whenever V_{CC} falls below the AUTOSTORE threshold voltage (V_{ASTH}). V_{CC} must remain above the AUTOSTORE Cycle End Voltage (V_{ASEND}) for the duration of the store cycle (t_{ASTO}). The detailed timing for this feature is illustrated in the AUTOSTORE timing diagram, below. Once the AUTOSTORE cycle is initiated, all other device functions are inhibited.

AUTOSTORE CYCLE Timing Diagram and Suggested AUTOSTORE Implementation Circuit

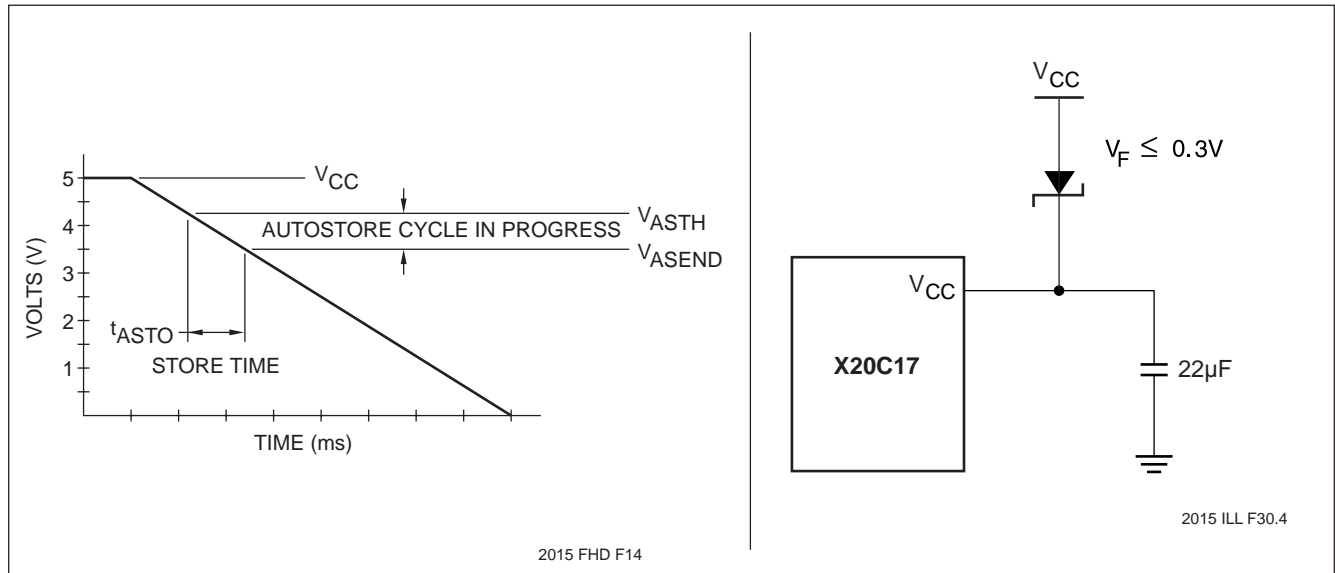

AUTOSTORE CYCLE LIMITS

Symbol	Parameter	X20C17		Units
		Min.	Max.	
$t_{ASTO}^{(5)}$	AUTOSTORE Cycle Time		2.5	ms
V_{ASTH}	AUTOSTORE Threshold Voltage	4.0	4.3	V
$V_{ASEND}^{(5)}$	AUTOSTORE Cycle End Voltage	3.5		V

2015 PGM T15

Note: (5) t_{ASTO} and V_{ASEND} are periodically sampled and not 100% tested.

X20C17

Normalized I_{CC} by Temperature over the V_{CC} Range and Frequency

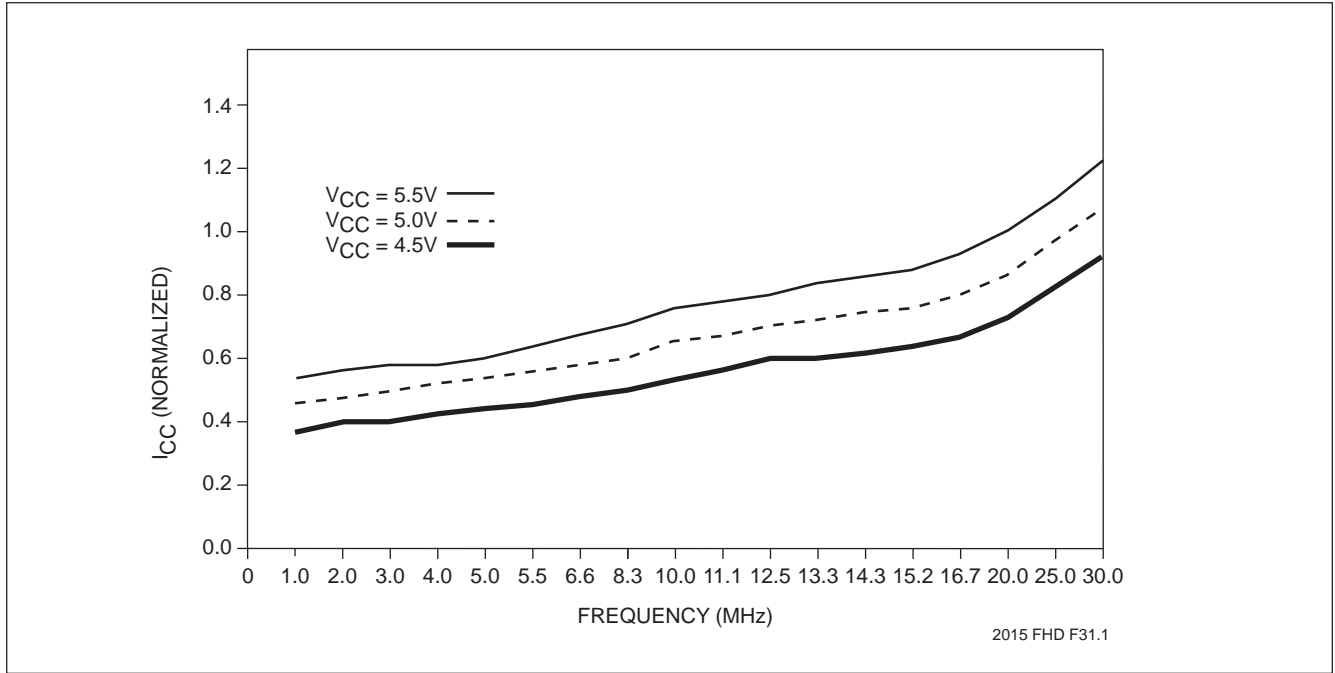

Normalized I_{CC} by Temperature over Frequency

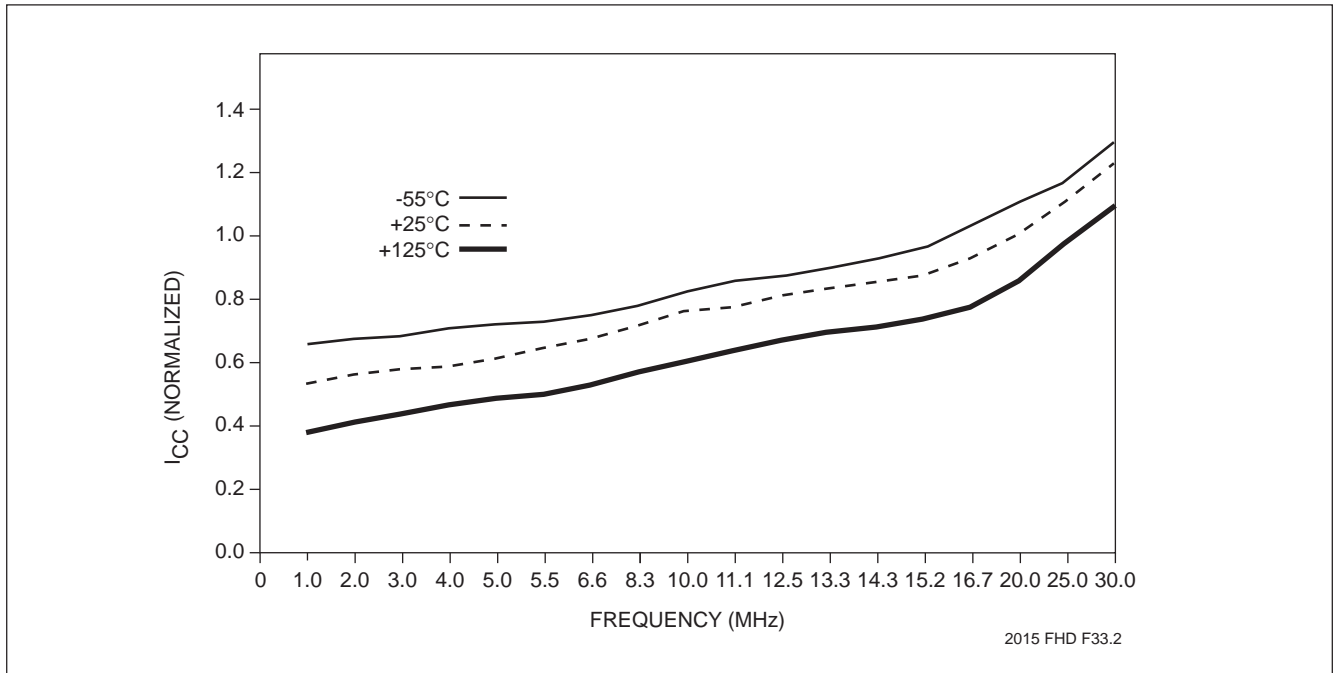

X20C17

PACKAGING INFORMATION

24-LEAD PLASTIC DUAL IN-LINE PACKAGE TYPE P

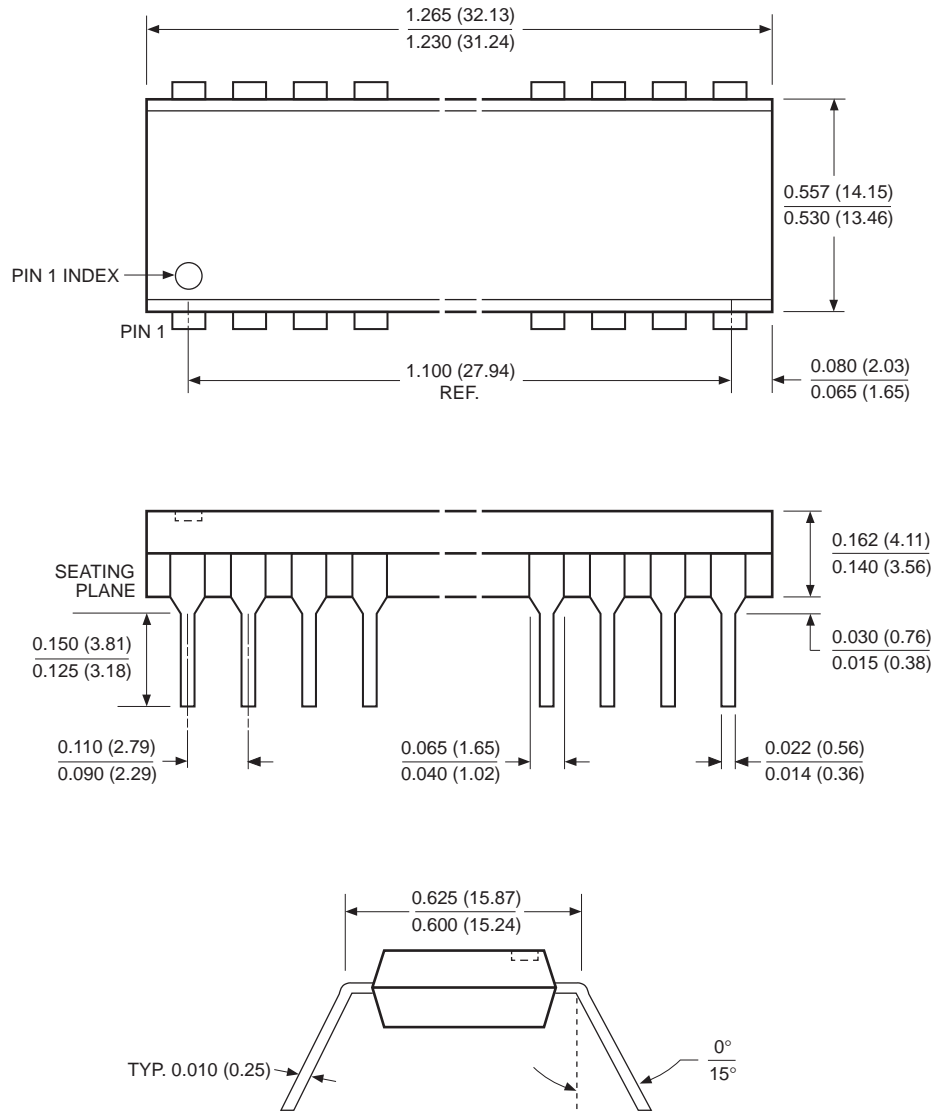

NOTE:

1. ALL DIMENSIONS IN INCHES (IN PARENTHESES IN MILLIMETERS)
2. PACKAGE DIMENSIONS EXCLUDE MOLDING FLASH

3926 FHD F03

X20C17

ORDERING INFORMATION

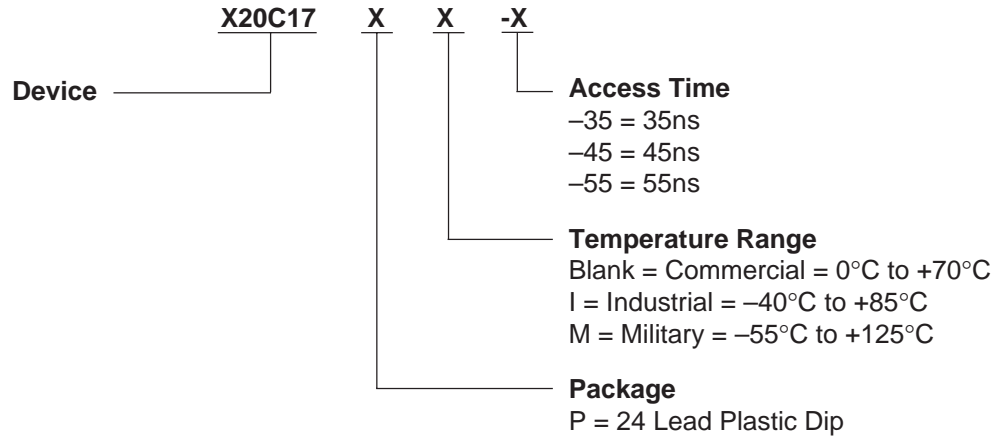

LIMITED WARRANTY

Devices sold by Xicor, Inc. are covered by the warranty and patent indemnification provisions appearing in its Terms of Sale only. Xicor, Inc. makes no warranty, express, statutory, implied, or by description regarding the information set forth herein or regarding the freedom of the described devices from patent infringement. Xicor, Inc. makes no warranty of merchantability or fitness for any purpose. Xicor, Inc. reserves the right to discontinue production and change specifications and prices at any time and without notice.

Xicor, Inc. assumes no responsibility for the use of any circuitry other than circuitry embodied in a Xicor, Inc. product. No other circuits, patents, licenses are implied.

US. PATENTS

Xicor products are covered by one or more of the following U.S. Patents: 4,263,664; 4,274,012; 4,300,212; 4,314,265; 4,326,134; 4,393,481; 4,404,475; 4,450,402; 4,486,769; 4,488,060; 4,520,461; 4,533,846; 4,599,706; 4,617,652; 4,668,932; 4,752,912; 4,829,482; 4,874,967; 4,883,976. Foreign patents and additional patents pending.

LIFE RELATED POLICY

In situations where semiconductor component failure may endanger life, system designers using this product should design the system with appropriate error detection and correction, redundancy and back-up features to prevent such an occurrence.

Xicor's products are not authorized for use as critical components in life support devices or systems.

1. Life support devices or systems are devices or systems which, (a) are intended for surgical implant into the body, or (b) support or sustain life, and whose failure to perform, when properly used in accordance with instructions for use provided in the labeling, can be reasonably expected to result in a significant injury to the user.
2. A critical component is any component of a life support device or system whose failure to perform can be reasonably expected to cause the failure of the life support device or system, or to affect its safety or effectiveness.