



Terminal Voltage $\pm 5V$, 100 Taps, Log Taper

X9C303

Digitally Controlled Potentiometer (XDCP™)

FEATURES

- Solid-state potentiometer
- Three-wire serial interface
- 100 wiper tap points
 - Wiper position stored in nonvolatile memory and recalled on power-up
- 99 resistive elements, log taper
 - Temperature compensated
 - End to end resistance, $\pm 15\%$
 - Terminal voltages, $\pm 5V$
- Low power CMOS
 - $V_{CC} = 5V$
 - Active current, 3mA max.
 - Standby current, 750 μA max.
- High reliability
 - Endurance, 100,000 data changes per bit
 - Register data retention, 100 years
- X9C303, 32 k Ω
- Packages
 - 8-lead TSSOP
 - 8-lead SOIC
 - 8-pin DIP

DESCRIPTION

The Xicor X9C303 is a digitally controlled potentiometer (XDCP). The device consists of a resistor array, wiper switches, a control section, and nonvolatile memory. The wiper position is controlled by a three-wire interface.

The resistor array is composed of 99 resistive elements. Between each element and at either end are tap points accessible to the wiper terminal. The position of the wiper element is controlled by the \overline{CS} , U/\overline{D} , and \overline{INC} inputs. The position of the wiper can be stored in nonvolatile memory and then be recalled upon a subsequent power-up operation.

The device can be used as a three-terminal potentiometer or as a two-terminal variable resistor in a wide variety of applications ranging from control, to signal processing, to parameter adjustment. Digitally-controlled potentiometers provide three powerful application advantages; (1) the variability and reliability of a solid-state potentiometer, (2) the flexibility of computer-based digital controls, and (3) the use of nonvolatile memory for potentiometer settings retention.

BLOCK DIAGRAM

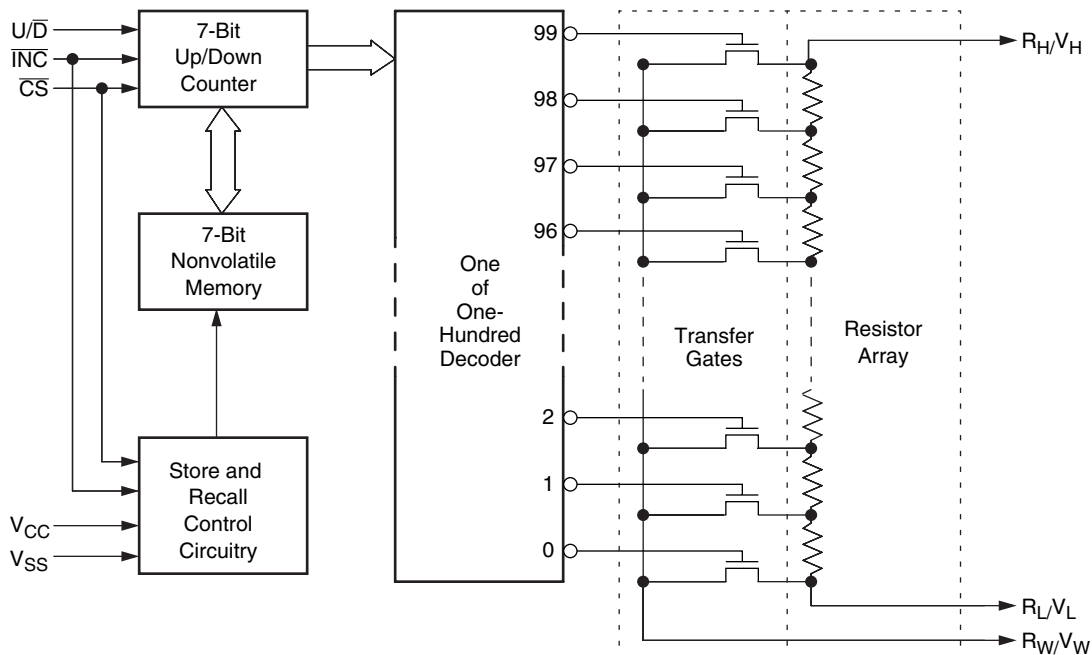

XDCP™ is a trademark of Xicor, Inc.

X9C303

PIN DESCRIPTIONS

V_H and V_L

The high (V_H) and low (V_L) terminals of the device are equivalent to the fixed terminals of a mechanical potentiometer. The minimum voltage is $-5V$ and the maximum is $+5V$. It should be noted that the terminology of V_L and V_H references the relative position of the terminal in relation to wiper movement direction selected by the U/\bar{D} input and not the voltage potential on the terminal.

V_W

V_W is the wiper terminal, equivalent to the movable terminal of a mechanical potentiometer. The position of the wiper within the array is determined by the control inputs. The wiper terminal series resistance is typically 40Ω .

Up/Down (U/\bar{D})

The U/\bar{D} input controls the direction of the wiper movement and whether the counter is incremented or decremented.

Increment (\bar{INC})

The \bar{INC} input is negative-edge triggered. Toggling \bar{INC} will move the wiper and either increment or decrement the counter in the direction indicated by the logic level on the U/\bar{D} input.

Chip Select (\bar{CS})

The device is selected when the \bar{CS} input is LOW. The current counter value is stored in nonvolatile memory when \bar{CS} is returned HIGH while the \bar{INC} input is also HIGH. After the store operation is complete the device will be placed in the low power standby mode until the device is selected once again.

PIN CONFIGURATION

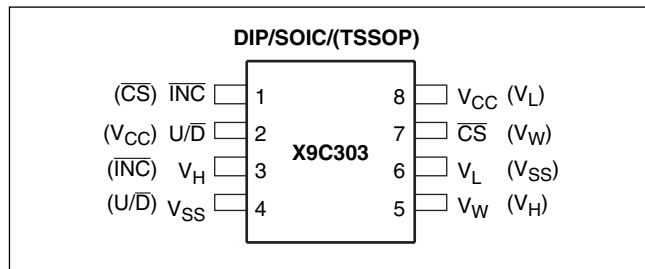

PIN NAMES

Symbol	Description
V_H	High Terminal (Potentiometer)
V_W	Wiper Terminal (Potentiometer)
V_L	Low Terminal (Potentiometer)
V_{SS}	Ground
V_{CC}	Supply Voltage
U/\bar{D}	Up/Down Control Input
\bar{INC}	Increment Control Input
\bar{CS}	Chip Select Control Input
NC	No Connection

POTENTIOMETER RELATIONSHIPS

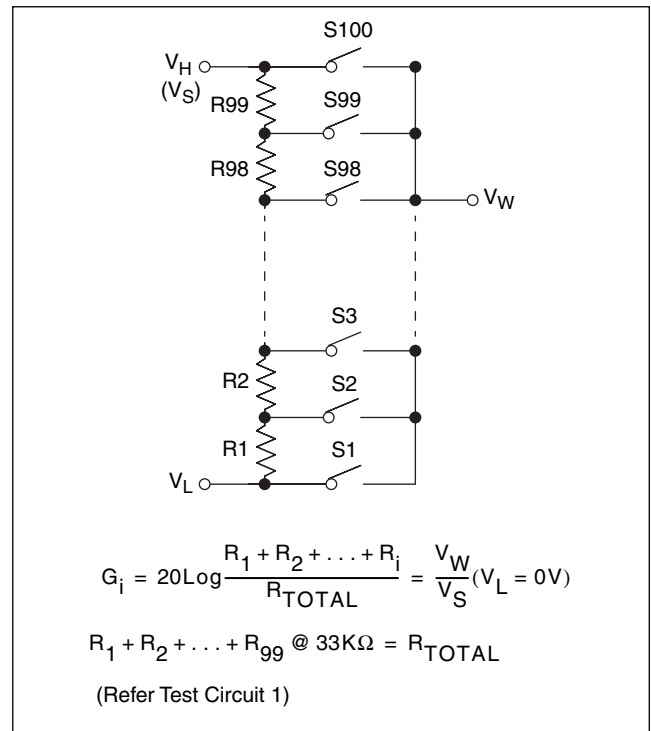

X9C303

PRINCIPLES OF OPERATION

There are three sections of the X9C303: the input control, counter and decode section; the nonvolatile memory; and the resistor array. The input control section operates just like an up/down counter. The output of this counter is decoded to turn on a single electronic switch connecting a point on the resistor array to the wiper output. Under the proper conditions the contents of the counter can be stored in nonvolatile memory and retained for future use. The resistor array is comprised of 99 individual resistors connected in series. At either end of the array and between each resistor is an electronic switch that transfers the potential at that point to the wiper.

The wiper, when at either fixed terminal, acts like its mechanical equivalent and does not move beyond the last position. That is, the counter does not wrap around when clocked to either extreme.

The electronic switches on the device operate in a “make before break” mode when the wiper changes tap positions. If the wiper is moved several positions, multiple taps are connected to the wiper for t_{WV} (\overline{INC} to V_W change). The R_{TOTAL} value for the device can temporarily be reduced by a significant amount if the wiper is moved several positions.

When the device is powered-down, the last counter position stored will be maintained in the nonvolatile memory. When power is restored, the contents of the memory are recalled and the counter is reset to the value last stored.

Instructions and Programming

The \overline{INC} , U/\overline{D} and \overline{CS} inputs control the movement of the wiper along the resistor array. With \overline{CS} set LOW the device is selected and enabled to respond to the U/\overline{D} and \overline{INC} inputs. HIGH to LOW transitions on \overline{INC} will increment or decrement (depending on the state of the U/\overline{D} input) a seven-bit counter. The output of this counter is decoded to select one of one-hundred wiper positions along the resistive array.

The value of the counter is stored in nonvolatile memory whenever \overline{CS} transitions HIGH while the \overline{INC} input is also HIGH.

The system may select the X9C303, move the wiper, and deselect the device without having to store the latest wiper position in nonvolatile memory. The wiper movement is performed as described above; once the new position is reached, the system would keep \overline{INC} LOW while taking \overline{CS} HIGH. The new wiper position would be maintained until changed by the system or until a power-down/up cycle recalled the previously stored data.

This would allow the system to always power-up to a preset value stored in nonvolatile memory; then during system operation minor adjustments could be made. The adjustments might be based on user preference: system parameter changes due to temperature drift, etc...

The state of U/\overline{D} may be changed while \overline{CS} remains LOW. This allows the host system to enable the device and then move the wiper up and down until the proper trim is attained.

MODE SELECTION

\overline{CS}	\overline{INC}	U/\overline{D}	Mode
L		H	Wiper Up
L		L	Wiper Down
	H	X	Store Wiper Position
H	X	X	Standby Current
	L	X	No Store, Return to Standby

SYMBOL TABLE

WAVEFORM	INPUTS	OUTPUTS
	Must be steady	Will be steady
	May change from Low to High	Will change from Low to High
	May change from High to Low	Will change from High to Low
	Don't Care: Changes Allowed	Changing: State Not Known
	N/A	Center Line is High Impedance

X9C303

ABSOLUTE MAXIMUM RATINGS

Temperature under bias-65°C to +135°C
 Storage temperature-65°C to +150°C
 Voltage on \overline{CS} , \overline{INC} , U/\overline{D} and V_{CC}
 with respect to V_{SS} -1V to +7V
 Voltage on V_H and V_L
 referenced to V_{SS} -8V to +8V
 $\Delta V = |V_H - V_L|$ X9C303 10V
 Lead temperature (soldering, 10 seconds)..... +300°C
 Wiper current ± 1 mA

Typical wiper resistance 40 Ω at 1mA
 Typical resistor
 noise 23 nV (RMS)/ $\sqrt{\text{Hz}}$ at 1kHzPHZ
 Typical charge pump noise.. 20 mV (RMS) @ 2.5 MHz

COMMENT

Stresses above those listed under “Absolute Maximum Ratings” may cause permanent damage to the device. This is a stress rating only; functional operation of the device (at these or any other conditions above those listed in the operational sections of this specification) is not implied. Exposure to absolute maximum rating conditions for extended periods may affect device reliability.

Relative Variation

Relative variation is a measure of the error in step size between taps = $\log(V_{w(n)}) - \log(V_{w(n-1)}) = 0.045 \pm 0.003$ for tap n = 2 – 99

Temperature Coefficient

(-40°C to +85°C) X9C303 ± 400 ppm/°C
 Ratiometric temperature coefficient ± 20 ppm

ANALOG CHARACTERISTICS

Electrical Characteristics

End-to-end resistance tolerance $\pm 15\%$
 Power rating at 25°C X9C303 10mW
 Wiper current ± 1 mA Max.

Wiper Adjustability

Unlimited Wiper Adjustment (Non-Store operation)
 Wiper Position Store
 Operations 100,000 Data Changes per Bit

Physical Characteristics

Marking Includes
 Manufacturer's Trademark
 Resistance Value or Code
 Date Code

Typical Electrical Taper

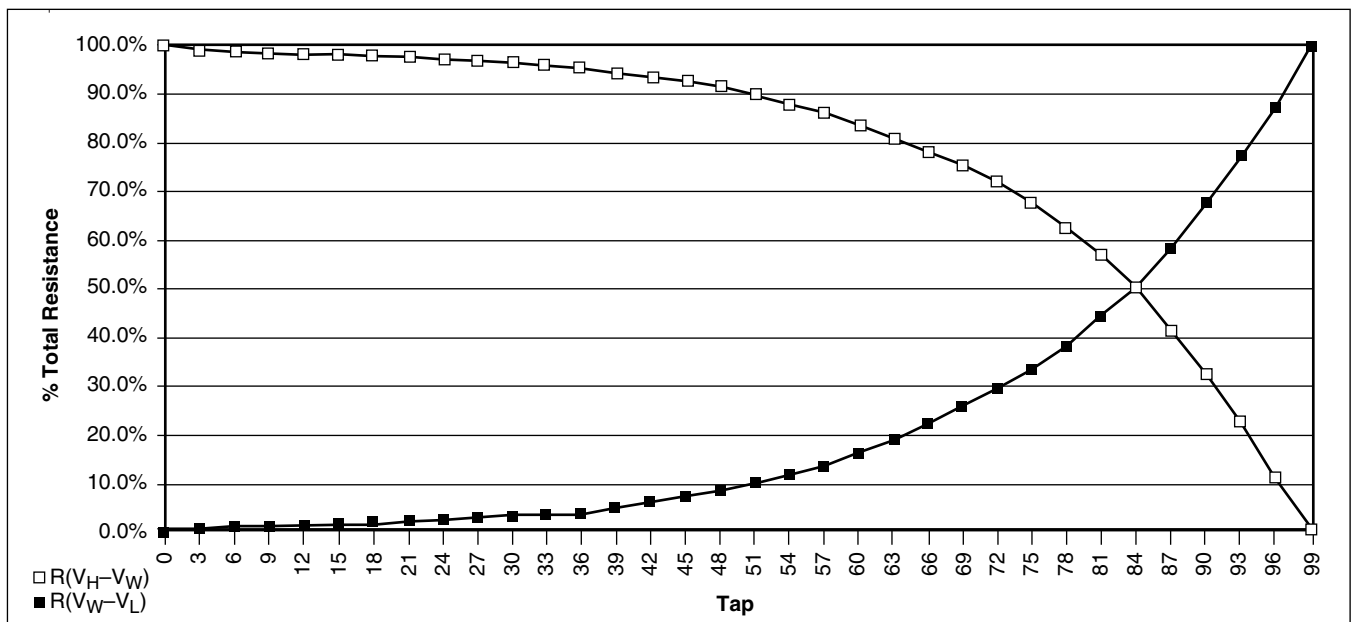

X9C303

Test Circuit #1

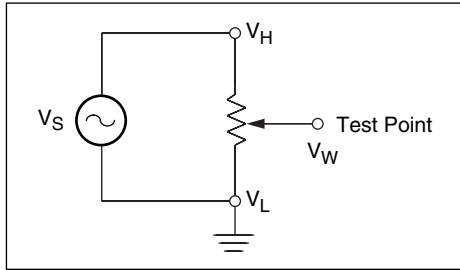

Test Circuit #2

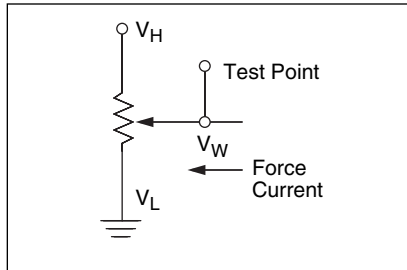

Circuit #3 SPICE Macro Model

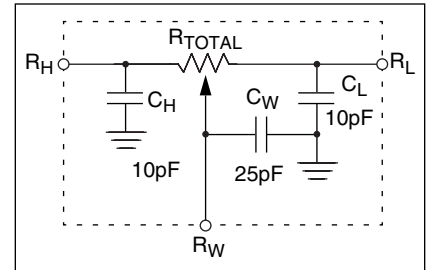

RECOMMENDED OPERATING CONDITIONS

Temperature	Min.	Max.
Commercial	0°C	+70°C
Industrial	-40°C	+85°C
Military	-55°C	+125°C

Supply Voltage	Limits
X9C303	5V ±10%

D.C. OPERATING CHARACTERISTICS (Over recommended operating conditions unless otherwise specified.)

Symbol	Parameter	Limits			Unit	Test Conditions
		Min.	Typ. ¹	Max.		
I _{CC}	V _{CC} active current		1	3	mA	$\overline{CS} = V_{IL}$, $U/\overline{D} = V_{IL}$ or V_{IH} and $\overline{INC} = 0.4V$ to $2.4V$ @ max. t_{CYC}
I _{SB}	Standby supply current		200	750	µA	$\overline{CS} = V_{CC} - 0.3V$, U/\overline{D} and $\overline{INC} = V_{SS}$ or $V_{CC} - 0.3V$
I _{LI}	\overline{CS} , \overline{INC} , U/\overline{D} input leakage current			±10	µA	$V_{IN} = V_{SS}$ to V_{CC}
V _{IH}	\overline{CS} , \overline{INC} , U/\overline{D} input HIGH voltage	2		V _{CC} + 1	V	
V _{IL}	\overline{CS} , \overline{INC} , U/\overline{D} input LOW voltage	-1		0.8	V	
R _W	Wiper resistance		40	100	Ω	Max. Wiper Current ±1mA
V _H	V _H terminal voltage	-5		+5	V	
V _L	V _L terminal voltage	-5		+5	V	
C _{IN} ⁽²⁾	\overline{CS} , \overline{INC} , U/\overline{D} input capacitance			10	pF	V _{CC} = 5V, V _{IN} = V _{SS} , T _A = 25°C, f = 1MHz
C _H /C _L /C _W	Potentiometer capacitance		10/10/25		pF	See Circuit 3

Standard Parts

Part Number	Maximum Resistance	Wiper Increments	Minimum Resistance
X9C303	32KΩ	Log Taper	40Ω Typical

Notes: (1) Typical values are for T_A = 25°C and nominal supply voltage.
 (2) This parameter is periodically sampled and not 100% tested.

X9C303

A.C. CONDITIONS OF TEST

Input pulse levels	0V to 3V
Input rise and fall times	10ns
Input reference levels	1.5V

A.C. OPERATING CHARACTERISTICS (Over recommended operating conditions unless otherwise specified)

Symbol	Parameter	Limits			Unit
		Min.	Typ. ³	Max.	
t_{CI}	\overline{CS} to \overline{INC} setup	100			ns
t_{ID}	\overline{INC} HIGH to U/\overline{D} change	100			ns
t_{DI}	U/\overline{D} to \overline{INC} setup	2.9			μ s
t_{IL}	\overline{INC} LOW period	1			μ s
t_{IH}	\overline{INC} HIGH period	1			μ s
t_{IC}	\overline{INC} inactive to \overline{CS} inactive	1			μ s
t_{CPH}	\overline{CS} deselect time	20			ms
t_{IW}	\overline{INC} to V_W change		100	500	μ s
t_{CYC}	\overline{INC} cycle time	4			μ s
t_R, t_F^4	\overline{INC} input rise and fall time			500	ns
t_{PU}^4	Power up to wiper stable			500	μ s
$t_R V_{CC}^4$	V_{CC} power-up rate	0.2		50	mV/ μ s

A.C. TIMING

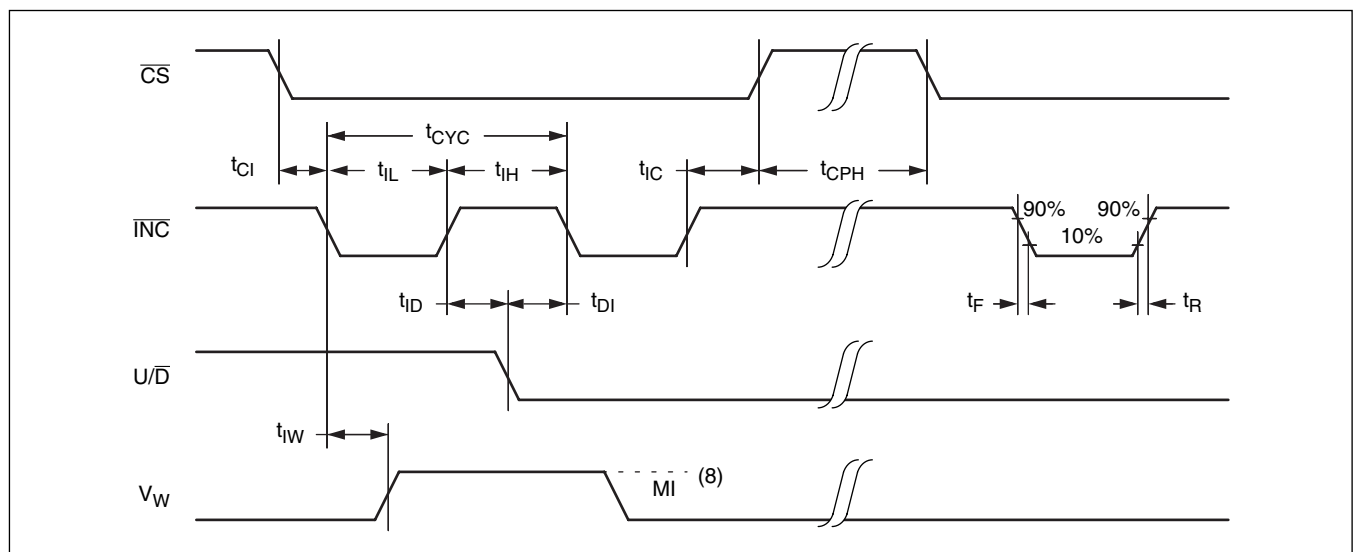

Notes: (3) Typical values are for $T_A = 25^\circ\text{C}$ and nominal supply voltage.

(4) This parameter is periodically sampled and not 100% tested.

(5) MI in the A.C. timing diagram refers to the minimum incremental change in the V_W output due to a change in the wiper position.

PACKAGING INFORMATION

8-Lead Plastic Dual In-Line Package Type P

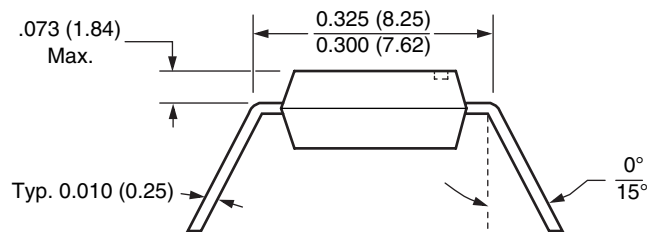
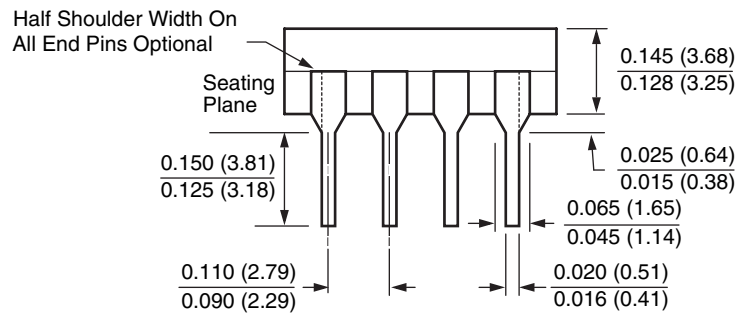
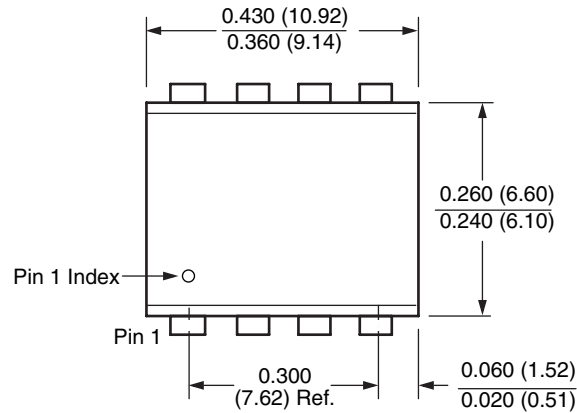

NOTE:

1. ALL DIMENSIONS IN INCHES (IN PARENTHESES IN MILLIMETERS)
2. PACKAGE DIMENSIONS EXCLUDE MOLDING FLASH

PACKAGING INFORMATION

8-Lead Plastic Small Outline Gull Wing Package Type S

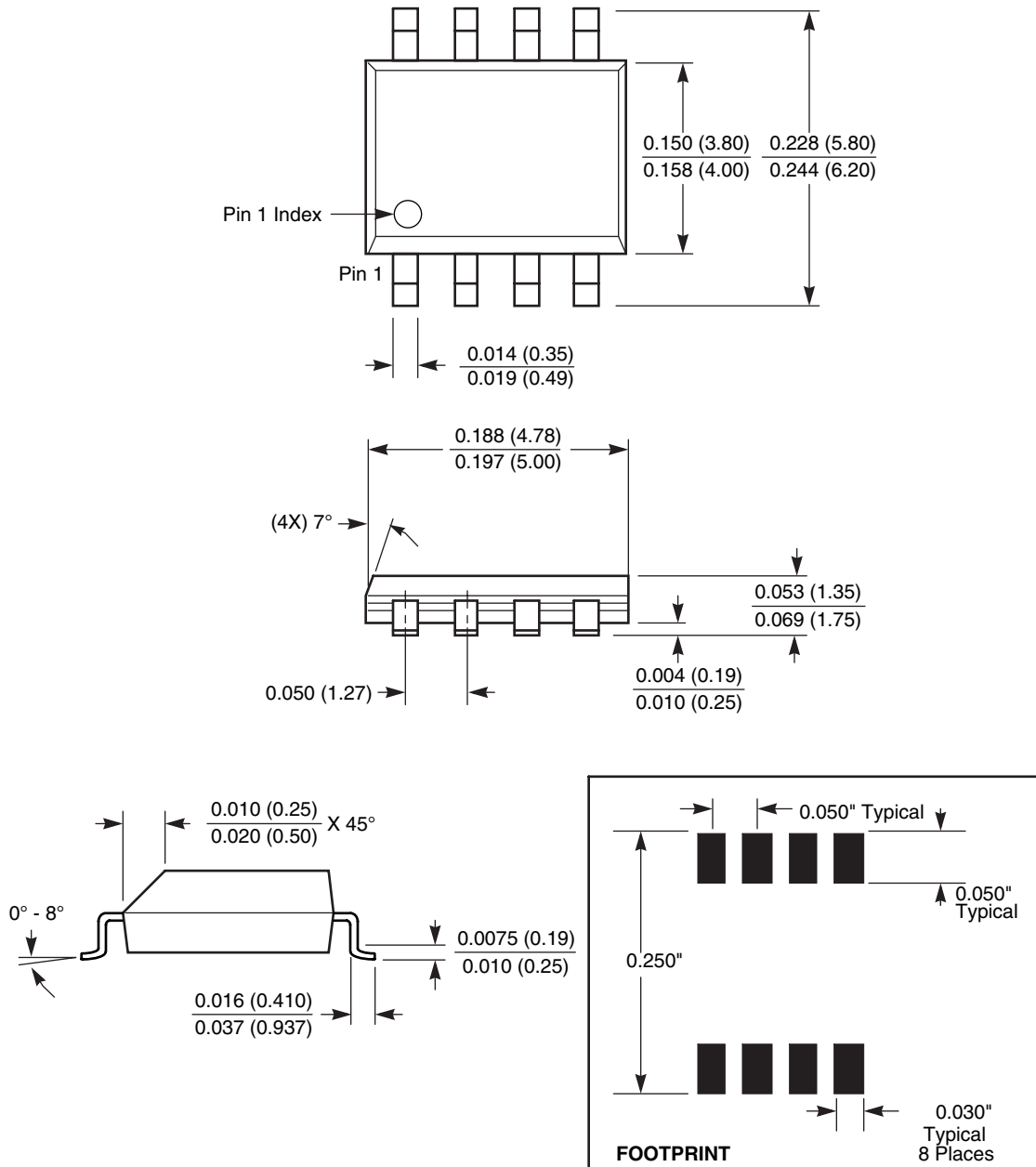

NOTE: ALL DIMENSIONS IN INCHES (IN PARENTHESES IN MILLIMETERS)

X9C303

PACKAGING INFORMATION

8-Lead Plastic, TSSOP, Package Type V

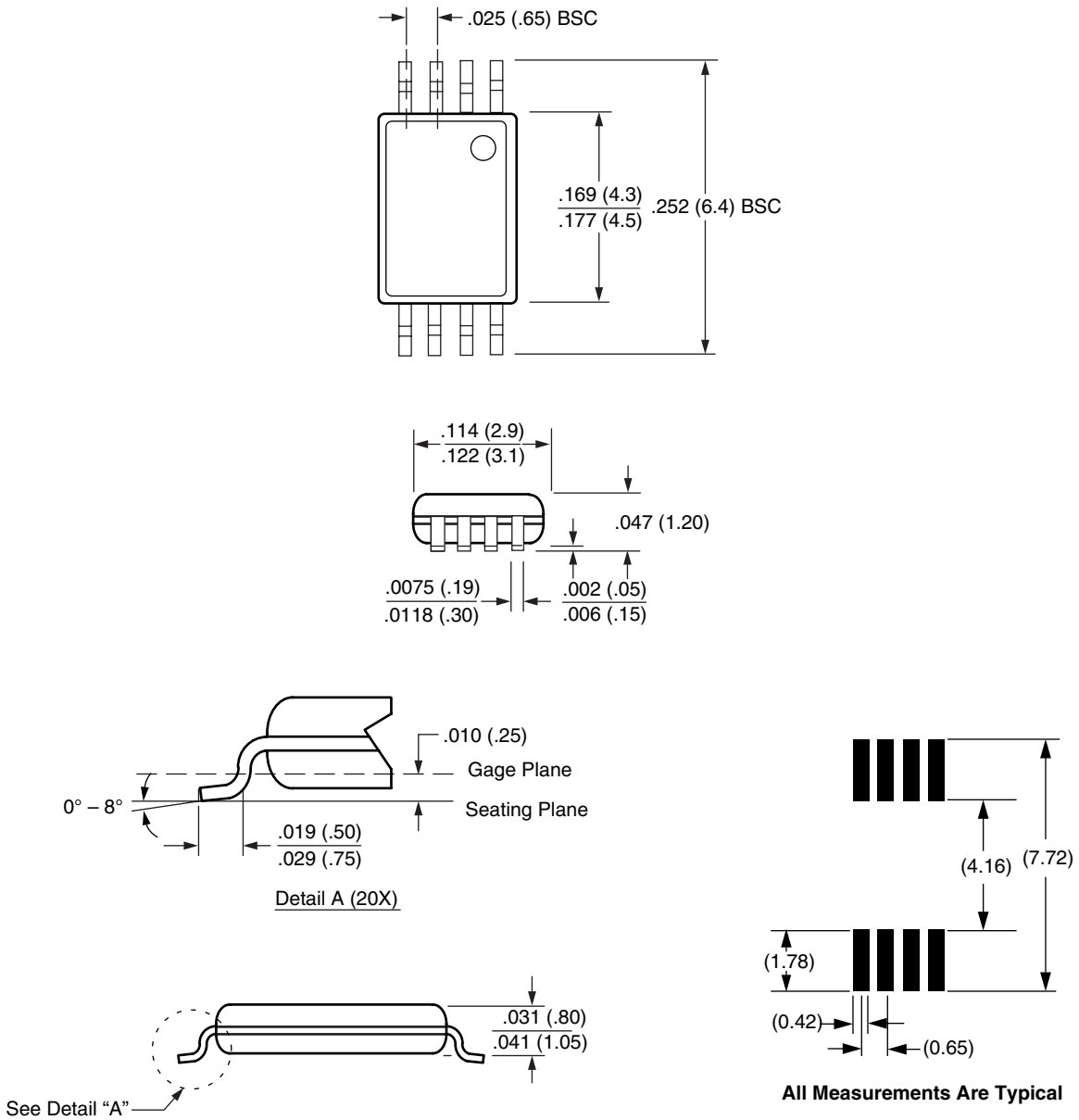

NOTE: ALL DIMENSIONS IN INCHES (IN PARENTHESES IN MILLIMETERS)

X9C303

Ordering Information

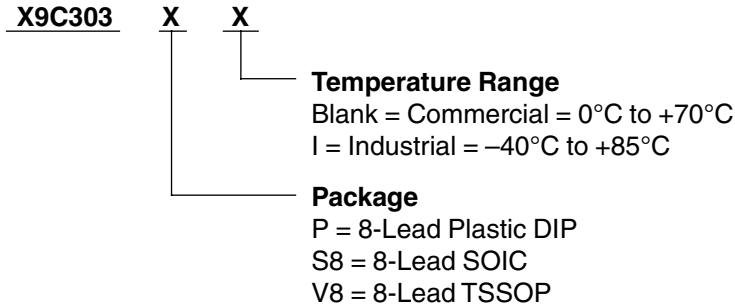

LIMITED WARRANTY

©Xicor, Inc. 2001 Patents Pending

Devices sold by Xicor, Inc. are covered by the warranty and patent indemnification provisions appearing in its Terms of Sale only. Xicor, Inc. makes no warranty, express, statutory, implied, or by description regarding the information set forth herein or regarding the freedom of the described devices from patent infringement. Xicor, Inc. makes no warranty of merchantability or fitness for any purpose. Xicor, Inc. reserves the right to discontinue production and change specifications and prices at any time and without notice.

Xicor, Inc. assumes no responsibility for the use of any circuitry other than circuitry embodied in a Xicor, Inc. product. No other circuits, patents, or licenses are implied.

COPYRIGHTS AND TRADEMARKS

Xicor, Inc., the Xicor logo, E²POT, XDCP, XBGA, AUTOSTORE, Direct Write cell, Concurrent Read-Write, PASS, MPS, PushPOT, Block Lock, IdentiPROM, E²KEY, X24C16, SecureFlash, and SerialFlash are all trademarks or registered trademarks of Xicor, Inc. All other brand and product names mentioned herein are used for identification purposes only, and are trademarks or registered trademarks of their respective holders.

U.S. PATENTS

Xicor products are covered by one or more of the following U.S. Patents: 4,326,134; 4,393,481; 4,404,475; 4,450,402; 4,486,769; 4,488,060; 4,520,461; 4,533,846; 4,599,706; 4,617,652; 4,668,932; 4,752,912; 4,829,482; 4,874,967; 4,883,976; 4,980,859; 5,012,132; 5,003,197; 5,023,694; 5,084,667; 5,153,880; 5,153,691; 5,161,137; 5,219,774; 5,270,927; 5,324,676; 5,434,396; 5,544,103; 5,587,573; 5,835,409; 5,977,585. Foreign patents and additional patents pending.

LIFE RELATED POLICY

In situations where semiconductor component failure may endanger life, system designers using this product should design the system with appropriate error detection and correction, redundancy and back-up features to prevent such an occurrence.

Xicor's products are not authorized for use in critical components in life support devices or systems.

1. Life support devices or systems are devices or systems which, (a) are intended for surgical implant into the body, or (b) support or sustain life, and whose failure to perform, when properly used in accordance with instructions for use provided in the labeling, can be reasonably expected to result in a significant injury to the user.
2. A critical component is any component of a life support device or system whose failure to perform can be reasonably expected to cause the failure of the life support device or system, or to affect its safety or effectiveness.