

Digitally Controlled Potentiometer (XDCP™)

FEATURES

- Solid-state potentiometer
- Three-wire serial interface
- 100 wiper tap points
 - Wiper position stored in nonvolatile memory and recalled on power-up
- 99 resistive elements, log taper
 - Temperature compensated
 - End to end resistance, $\pm 15\%$
 - Terminal voltages, $\pm 5V$
- Low power CMOS
 - $V_{CC} = 5V$
 - Active current, 3mA max.
 - Standby current, 750 μ A max.
- High reliability
 - Endurance, 100,000 data changes per bit
 - Register data retention, 100 years
- X9C303, 32k Ω
- Packages
 - 8-lead TSSOP
 - 8-lead SOIC
 - 8-pin DIP

DESCRIPTION

The Intersil X9C303 is a digitally controlled potentiometer (XDCP). The device consists of a resistor array, wiper switches, a control section, and nonvolatile memory. The wiper position is controlled by a three-wire interface.

The resistor array is composed of 99 resistive elements. Between each element and at either end are tap points accessible to the wiper terminal. The position of the wiper element is controlled by the \overline{CS} , U/\overline{D} , and \overline{INC} inputs. The position of the wiper can be stored in nonvolatile memory and then be recalled upon a subsequent power-up operation.

The device can be used as a three-terminal potentiometer or as a two-terminal variable resistor in a wide variety of applications ranging from control, to signal processing, to parameter adjustment. Digitally-controlled potentiometers provide three powerful application advantages; (1) the variability and reliability of a solid-state potentiometer, (2) the flexibility of computer-based digital controls, and (3) the use of nonvolatile memory for potentiometer settings retention.

BLOCK DIAGRAM

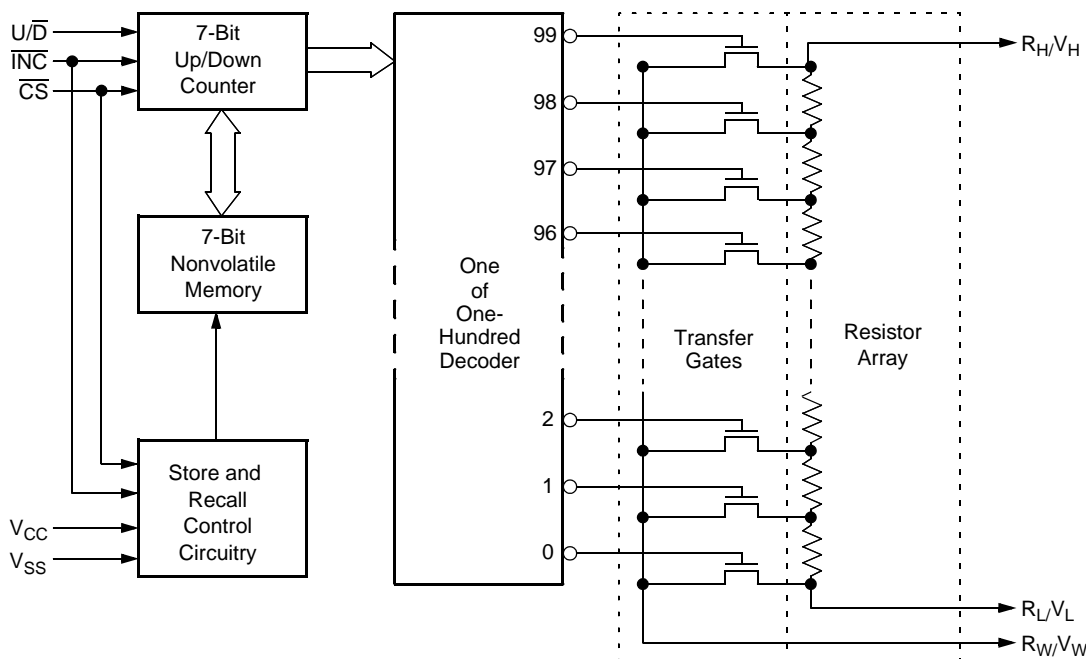

PIN DESCRIPTIONS

V_H and V_L

The high (V_H) and low (V_L) terminals of the device are equivalent to the fixed terminals of a mechanical potentiometer. The minimum voltage is -5V and the maximum is +5V. It should be noted that the terminology of V_L and V_H references the relative position of the terminal in relation to wiper movement direction selected by the U/ \bar{D} input and not the voltage potential on the terminal.

V_W

V_W is the wiper terminal, equivalent to the movable terminal of a mechanical potentiometer. The position of the wiper within the array is determined by the control inputs. The wiper terminal series resistance is typically 40Ω.

Up/Down (U/ \bar{D})

The U/ \bar{D} input controls the direction of the wiper movement and whether the counter is incremented or decremented.

Increment (\bar{INC})

The \bar{INC} input is negative-edge triggered. Toggling \bar{INC} will move the wiper and either increment or decrement the counter in the direction indicated by the logic level on the U/ \bar{D} input.

Chip Select (\bar{CS})

The device is selected when the \bar{CS} input is LOW. The current counter value is stored in nonvolatile memory when \bar{CS} is returned HIGH while the \bar{INC} input is also HIGH. After the store operation is complete the device will be placed in the low power standby mode until the device is selected once again.

PIN CONFIGURATION

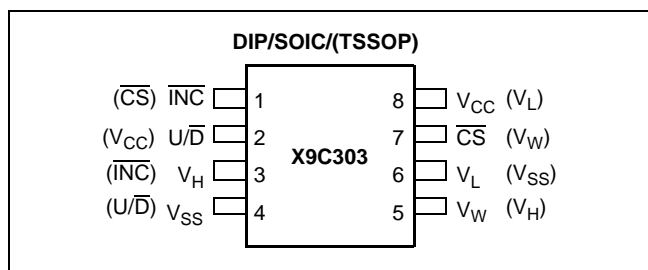

PIN NAMES

| Symbol | Description |
|-----------------|--------------------------------|
| V _H | High Terminal (Potentiometer) |
| V _W | Wiper Terminal (Potentiometer) |
| V _L | Low Terminal (Potentiometer) |
| V _{SS} | Ground |
| V _{CC} | Supply Voltage |
| U/ \bar{D} | Up/Down Control Input |
| \bar{INC} | Increment Control Input |
| \bar{CS} | Chip Select Control Input |
| NC | No Connection |

POTENTIOMETER RELATIONSHIPS

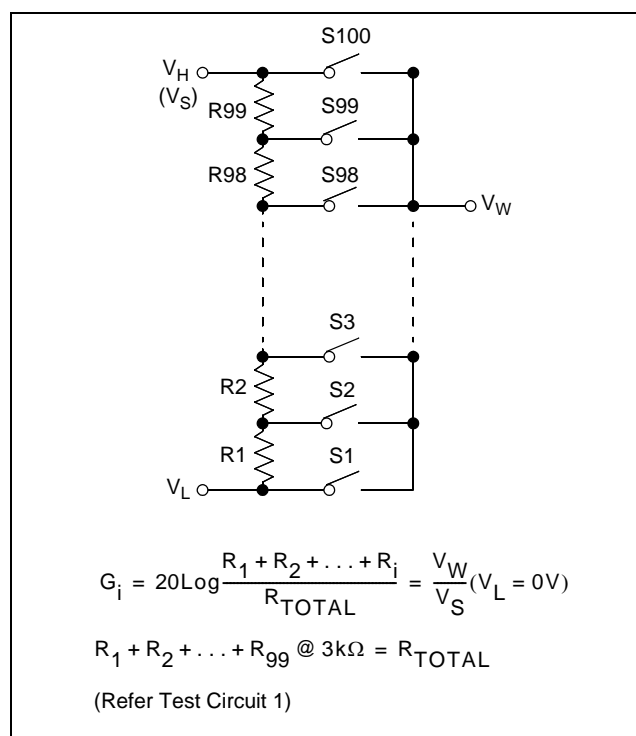

PRINCIPLES OF OPERATION

There are three sections of the X9C303: the input control, counter and decode section; the nonvolatile memory; and the resistor array. The input control section operates just like an up/down counter. The output of this counter is decoded to turn on a single electronic switch connecting a point on the resistor array to the wiper output. Under the proper conditions the contents of the counter can be stored in nonvolatile memory and retained for future use. The resistor array is comprised of 99 individual resistors connected in series. At either end of the array and between each resistor is an electronic switch that transfers the potential at that point to the wiper.

The wiper, when at either fixed terminal, acts like its mechanical equivalent and does not move beyond the last position. That is, the counter does not wrap around when clocked to either extreme.

The electronic switches on the device operate in a “make before break” mode when the wiper changes tap positions. If the wiper is moved several positions, multiple taps are connected to the wiper for t_{1W} (\overline{INC} to V_W change). The R_{TOTAL} value for the device can temporarily be reduced by a significant amount if the wiper is moved several positions.

When the device is powered-down, the last counter position stored will be maintained in the nonvolatile memory. When power is restored, the contents of the memory are recalled and the counter is reset to the value last stored.

Instructions and Programming

The \overline{INC} , U/\overline{D} and \overline{CS} inputs control the movement of the wiper along the resistor array. With \overline{CS} set LOW the device is selected and enabled to respond to the U/\overline{D} and \overline{INC} inputs. HIGH to LOW transitions on \overline{INC} will increment or decrement (depending on the state of the U/\overline{D} input) a seven-bit counter. The output of this counter is decoded to select one of one-hundred wiper positions along the resistive array.

The value of the counter is stored in nonvolatile memory whenever \overline{CS} transitions HIGH while the \overline{INC} input is also HIGH.

The system may select the X9C303, move the wiper, and deselect the device without having to store the latest wiper position in nonvolatile memory. The wiper movement is performed as described above; once the new position is reached, the system would keep \overline{INC} LOW while taking \overline{CS} HIGH. The new wiper position would be maintained until changed by the system or until a power-down/up cycle recalled the previously stored data.

This would allow the system to always power-up to a preset value stored in nonvolatile memory; then during system operation minor adjustments could be made. The adjustments might be based on user preference: system parameter changes due to temperature drift, etc...

The state of U/\overline{D} may be changed while \overline{CS} remains LOW. This allows the host system to enable the device and then move the wiper up and down until the proper trim is attained.

MODE SELECTION

| \overline{CS} | \overline{INC} | U/\overline{D} | Mode |
|-----------------|------------------|------------------|-----------------------------|
| L | | H | Wiper Up |
| L | | L | Wiper Down |
| | H | X | Store Wiper Position |
| H | X | X | Standby Current |
| | L | X | No Store, Return to Standby |

SYMBOL TABLE

| WAVEFORM | INPUTS | OUTPUTS |
|----------|-----------------------------|-------------------------------|
| | Must be steady | Will be steady |
| | May change from Low to High | Will change from Low to High |
| | May change from High to Low | Will change from High to Low |
| | Don't Care: Changes Allowed | Changing: State Not Known |
| | N/A | Center Line is High Impedance |

ABSOLUTE MAXIMUM RATINGS

Temperature under bias -65°C to +135°C
 Storage temperature -65°C to +150°C
 Voltage on \overline{CS} , \overline{INC} , U/\overline{D} and V_{CC}
 with respect to V_{SS} -1V to +7V
 Voltage on V_H and V_L
 referenced to V_{SS} -8V to +8V
 $\Delta V = |V_H - V_L|$ X9C303 10V
 Lead temperature (soldering, 10 seconds) +300°C
 Wiper current ± 1 mA

Typical wiper resistance 40 Ω at 1mA
 Typical resistor
 noise 23 nV (RMS)/ $\sqrt{\text{Hz}}$ at 1kHzPHZ
 Typical charge pump noise . 20 mV (RMS) @ 2.5 MHz

COMMENT

Stresses above those listed under “Absolute Maximum Ratings” may cause permanent damage to the device. This is a stress rating only; functional operation of the device (at these or any other conditions above those listed in the operational sections of this specification) is not implied. Exposure to absolute maximum rating conditions for extended periods may affect device reliability.

Relative Variation

Relative variation is a measure of the error in step size between taps = $\log(V_{w(n)}) - \log(V_{w(n-1)}) = 0.045 \pm 0.003$ for tap n = 2 - 99

Temperature Coefficient

(-40°C to +85°C) X9C303 ± 400 ppm/°C Typical
 Ratiometric temperature coefficient ± 20 ppm

ANALOG CHARACTERISTICS

Electrical Characteristics

End-to-end resistance tolerance $\pm 15\%$
 Power rating at 25°C X9C303 10mW
 Wiper current ± 1 mA Max.

Wiper Adjustability

Unlimited Wiper Adjustment (Non-Store operation)
 Wiper Position Store
 Operations 100,000 Data Changes per Bit

Physical Characteristics

Marking Includes
 Manufacturer’s Trademark
 Resistance Value or Code
 Date Code

Typical Electrical Taper

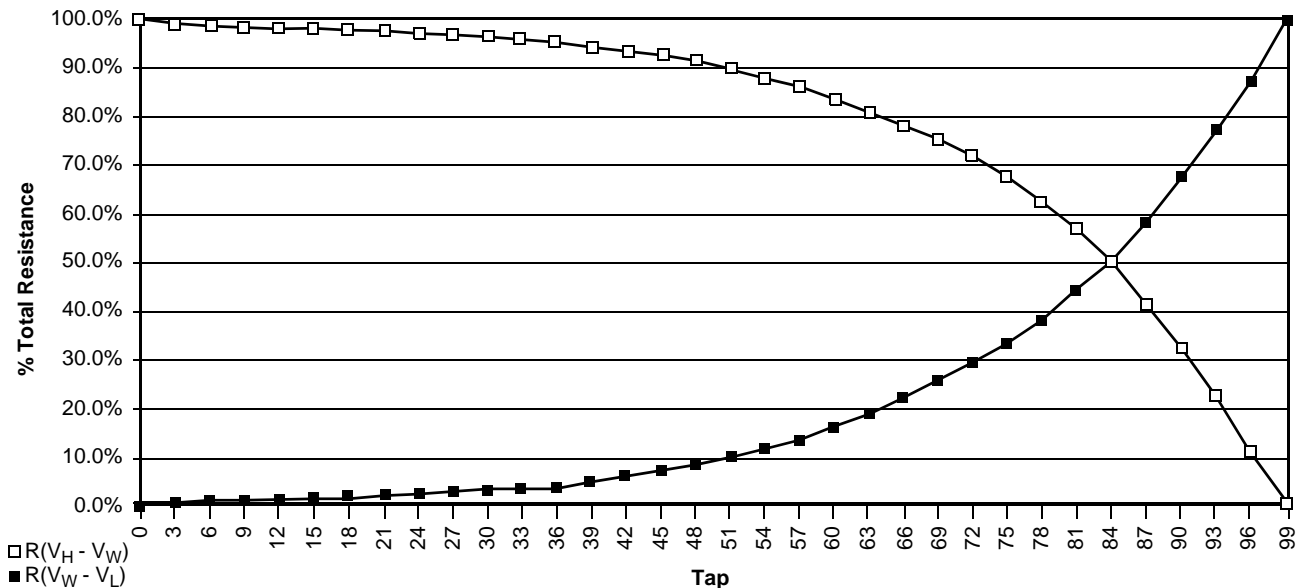

Test Circuit #1

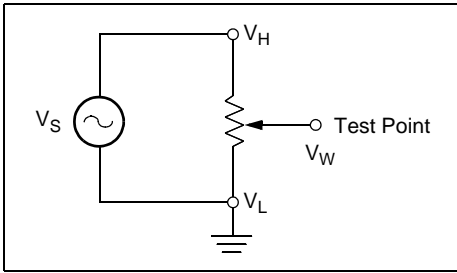

Test Circuit #2

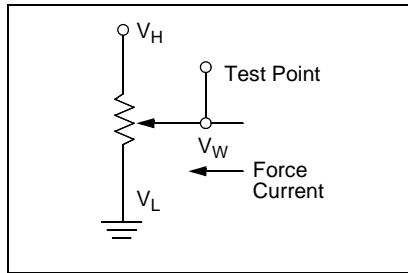

Circuit #3 SPICE Macro Model

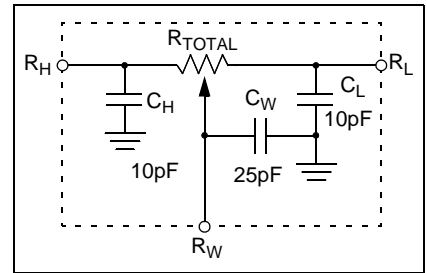

RECOMMENDED OPERATING CONDITIONS

| Temperature | Min. | Max. |
|-------------|-------|--------|
| Commercial | 0°C | +70°C |
| Industrial | -40°C | +85°C |
| Military | -55°C | +125°C |

| Supply Voltage | Limits |
|----------------|---------|
| X9C303 | 5V ±10% |

D.C. OPERATING CHARACTERISTICS (Over recommended operating conditions unless otherwise specified.)

| Symbol | Parameter | Limits | | | Unit | Test Conditions |
|--|---|--------|----------|---------------------|------|--|
| | | Min. | Typ. (1) | Max. | | |
| I _{CC} | V _{CC} active current | | 1 | 3 | mA | $\overline{CS} = V_{IL}$, $U/\overline{D} = V_{IL}$ or V_{IH} and $\overline{INC} = 0.4V$ to $2.4V$ @ max. t _{CYC} |
| I _{SB} | Standby supply current | | 200 | 750 | µA | $\overline{CS} = V_{CC} - 0.3V$, U/\overline{D} and $\overline{INC} = V_{SS}$ or $V_{CC} - 0.3V$ |
| I _{LI} | \overline{CS} , \overline{INC} , U/\overline{D} input leakage current | | | ±10 | µA | V _{IN} = V _{SS} to V _{CC} |
| V _{IH} | \overline{CS} , \overline{INC} , U/\overline{D} input HIGH voltage | 2 | | V _{CC} + 1 | V | |
| V _{IL} | \overline{CS} , \overline{INC} , U/\overline{D} input LOW voltage | -1 | | 0.8 | V | |
| R _W | Wiper resistance | | 40 | 100 | Ω | Max. Wiper Current ±1mA |
| V _H | V _H terminal voltage | -5 | | +5 | V | |
| V _L | V _L terminal voltage | -5 | | +5 | V | |
| C _{IN} (2) | \overline{CS} , \overline{INC} , U/\overline{D} input capacitance | | | 10 | pF | V _{CC} = 5V, V _{IN} = V _{SS} , T _A = 25°C, f = 1MHz |
| C _H /C _L /C _W | Potentiometer capacitance | | 10/10/25 | | pF | See Circuit 3 |

Standard Parts

| Part Number | Maximum Resistance | Wiper Increments | Minimum Resistance |
|-------------|--------------------|------------------|--------------------|
| X9C303 | 32kΩ | Log Taper | 40Ω Typical |

Notes: (1) Typical values are for T_A = 25°C and nominal supply voltage.
 (2) This parameter is periodically sampled and not 100% tested.

A.C. CONDITIONS OF TEST

| | |
|---------------------------|----------|
| Input pulse levels | 0V to 3V |
| Input rise and fall times | 10ns |
| Input reference levels | 1.5V |

A.C. OPERATING CHARACTERISTICS (Over recommended operating conditions unless otherwise specified)

| Symbol | Parameter | Limits | | | Unit |
|------------------|---|--------|----------|------|-------------|
| | | Min. | Typ. (3) | Max. | |
| t_{CI} | \overline{CS} to \overline{INC} setup | 100 | | | ns |
| t_{ID} | \overline{INC} HIGH to U/\overline{D} change | 100 | | | ns |
| t_{DI} | U/\overline{D} to \overline{INC} setup | 2.9 | | | μ s |
| t_{IL} | \overline{INC} LOW period | 1 | | | μ s |
| t_{IH} | \overline{INC} HIGH period | 1 | | | μ s |
| t_{IC} | \overline{INC} inactive to \overline{CS} inactive | 1 | | | μ s |
| t_{CPH} | \overline{CS} deselect time | 20 | | | ms |
| t_{IW} | \overline{INC} to V_W change | | 100 | 500 | μ s |
| t_{CYC} | \overline{INC} cycle time | 4 | | | μ s |
| t_R, t_F (4) | \overline{INC} input rise and fall time | | | 500 | ns |
| t_{PU} (4) | Power-up to wiper stable | | | 500 | μ s |
| $t_R V_{CC}$ (4) | V_{CC} power-up rate | 0.2 | | 50 | mV/ μ s |

A.C. TIMING

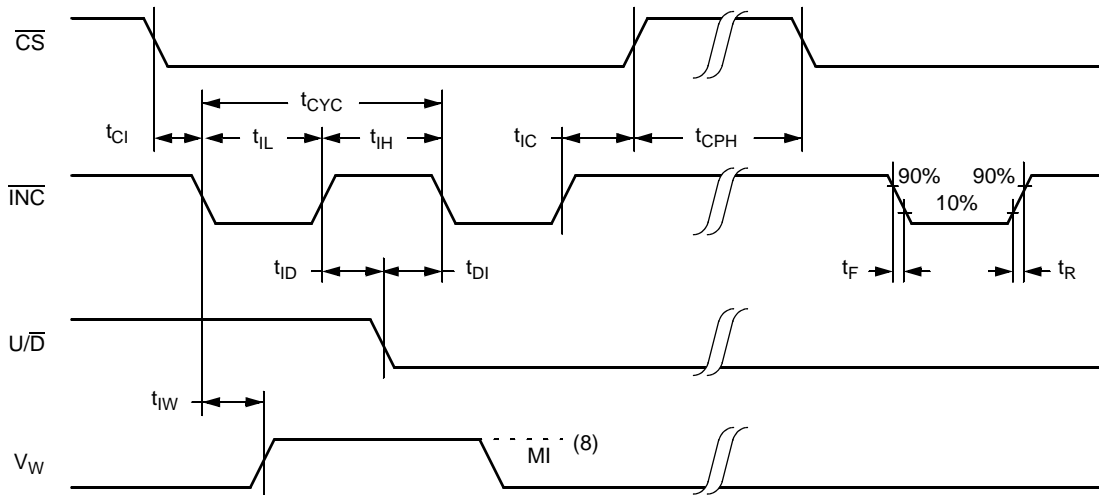

- Notes: (3) Typical values are for $T_A = 25^\circ\text{C}$ and nominal supply voltage.
 (4) This parameter is periodically sampled and not 100% tested.
 (5) MI in the A.C. timing diagram refers to the minimum incremental change in the V_W output due to a change in the wiper position.

PACKAGING INFORMATION

8-Lead Plastic Dual In-Line Package Type P

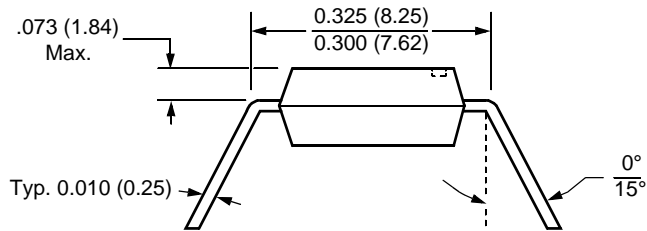
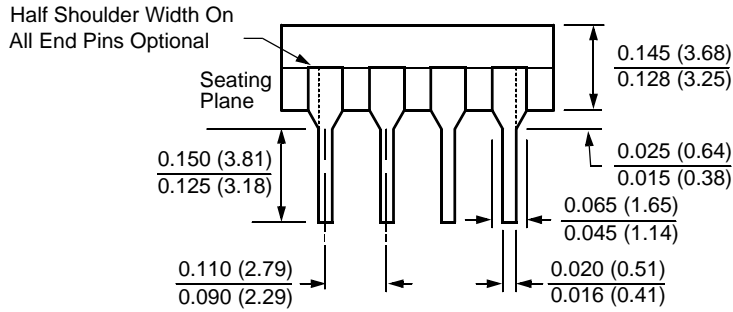
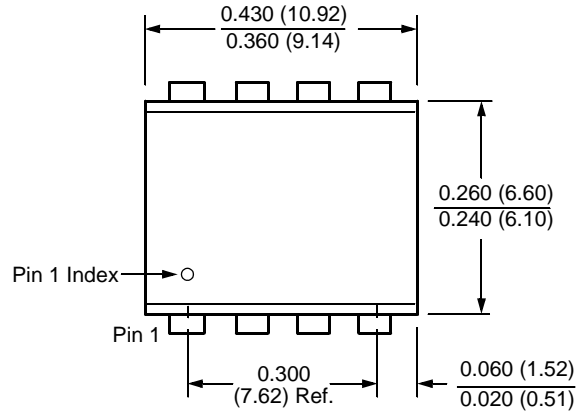

NOTE:

1. ALL DIMENSIONS IN INCHES (IN PARENTHESES IN MILLIMETERS)
2. PACKAGE DIMENSIONS EXCLUDE MOLDING FLASH

PACKAGING INFORMATION

8-Lead Plastic Small Outline Gull Wing Package Type S

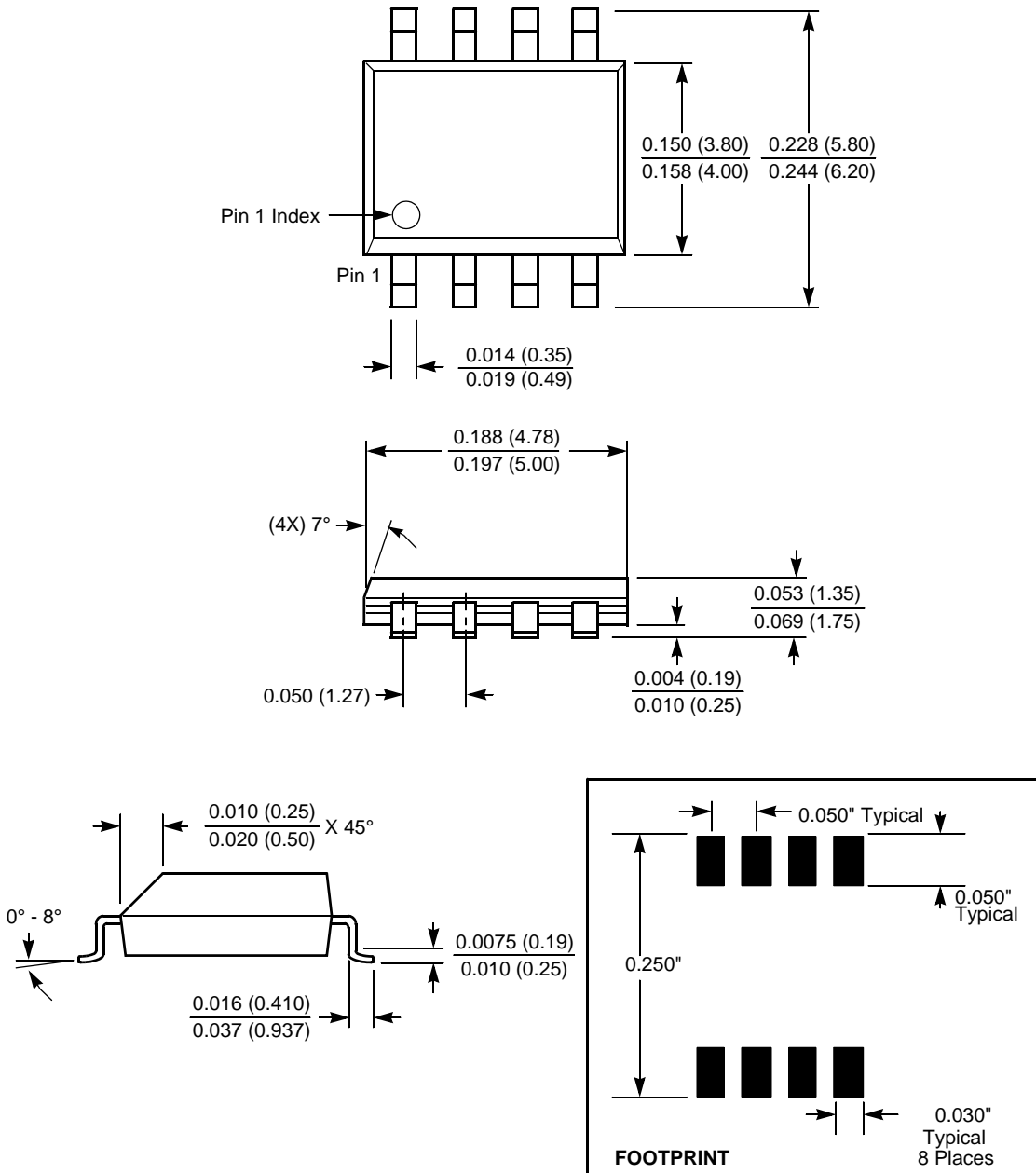

NOTE: ALL DIMENSIONS IN INCHES (IN PARENTHESES IN MILLIMETERS)

PACKAGING INFORMATION

8-Lead Plastic, TSSOP, Package Type V

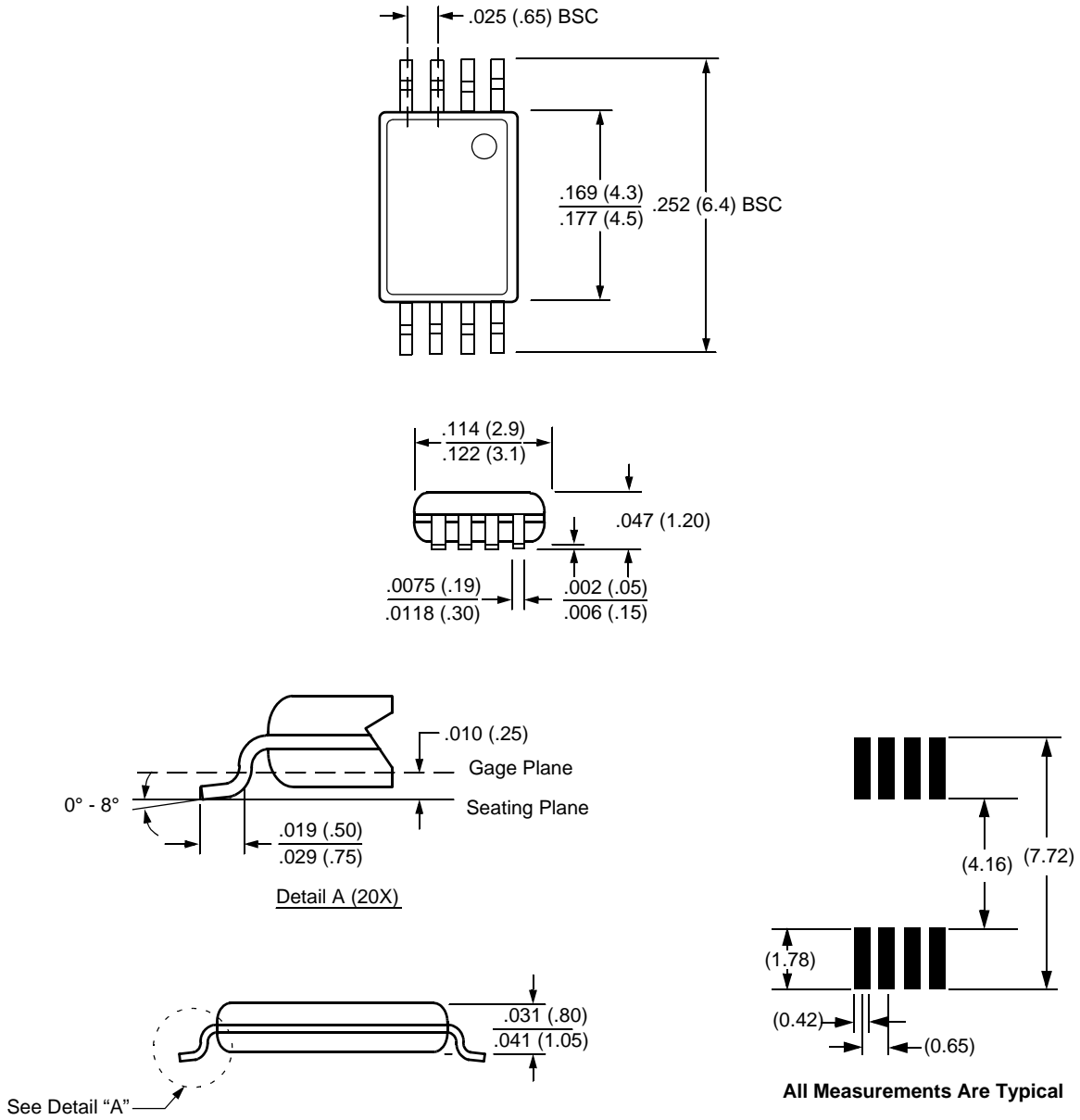

NOTE: ALL DIMENSIONS IN INCHES (IN PARENTHESES IN MILLIMETERS)

Ordering Information

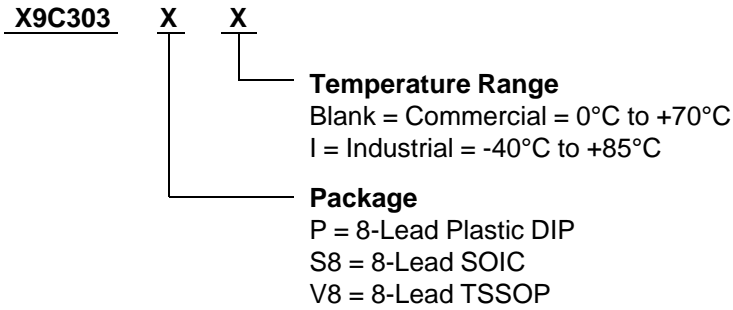

All Intersil U.S. products are manufactured, assembled and tested utilizing ISO9000 quality systems.
Intersil Corporation's quality certifications can be viewed at www.intersil.com/design/quality

Intersil products are sold by description only. Intersil Corporation reserves the right to make changes in circuit design, software and/or specifications at any time without notice. Accordingly, the reader is cautioned to verify that data sheets are current before placing orders. Information furnished by Intersil is believed to be accurate and reliable. However, no responsibility is assumed by Intersil or its subsidiaries for its use; nor for any infringements of patents or other rights of third parties which may result from its use. No license is granted by implication or otherwise under any patent or patent rights of Intersil or its subsidiaries.

For information regarding Intersil Corporation and its products, see www.intersil.com