

XC74WL74AASR



CMOS Logic

- ◆ CMOS Logic D-Type Flip Flop
- ◆ Operating Voltage Range : 2V ~ 5.5V
- ◆ High Speed Operations : $f_{max} = 170\text{MHz TYP}$
- ◆ Low Power Consumption : $1\mu\text{A (max)}$
- ◆ MSOP-8B Package

Applications

- Palmtops
- Digital Equipment

Description

XC74WL74AASR is D-Type Flip Flop manufactured using silicon gate CMOS processes. The small quiescent current, which is one of the features of the CMOS logic, gives way to high speed operations which enables LS-TTL.

With wave forming buffers connected internally, stabilized output can be achieved as the series offers high noise immunity.

As the series is integrated into a mini molded, MSOP-8B package, high density mounting is possible.

Features

- High Speed Operations** : $f_{max} = 170\text{MHz TYP (}V_{CC}=5\text{V)}$
- Operating Voltage Range**: 2V ~ 5.5V
- Low Power Consumption**: $1\mu\text{A (max)}$
- Small Package** : MSOP-8B

Pin Configuration

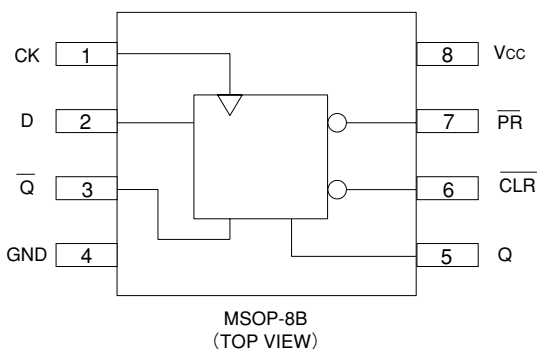

Functions

INPUT			OUTPUT		
$\overline{\text{PR}}$	$\overline{\text{CLR}}$	CK	D	Q	$\overline{\text{Q}}$
L	H	X	X	H	L
H	L	X	X	L	H
L	L	X	X	H	H
H	H	\uparrow	H	H	L
H	H	\downarrow	L	L	H
H	H	\downarrow	X	Q0	$\overline{\text{Q0}}$

H = High Level

L = Low Level

X = Don't care

Absolute Maximum Ratings

Ta=-40°C~85°C

PARAMETER	SYMBOL	CONDITIONS	UNITS
Power Supply Voltage	VCC	-0.5~+6.0	V
Input Voltage	VIN	-0.5~+6.0	V
Output Voltage	VOUT	-0.5~VCC+0.5	V
Input Diode Current	I _{IK}	-20	mA
Output Diode Current	I _{OK}	±20	mA
Switch Output Current	I _{OUT}	±25	mA
VCC, GND Current	I _{CC} , I _{GND}	±50	mA
Power Dissipation (Ta=25°C)	P _d	300	mW
Storage Temperature	T _{stg}	-65~+150	°C

Note : Voltage is all Ground standardized.

Recommended Operating Conditions

PARAMETER	SYMBOL	RATINGS	UNITS
Supply Voltage	VCC	2~5.5	V
Input Voltage	VIN	0~5.5	V
Output Voltage	VOUT	0~VCC	V
Operating Temperature	T _{opr}	-40~+85	°C
Input Rise and Fall Time	tr, tf	0~200 (VCC=3.3V)	ns
		0~100 (VCC=5V)	

DC Electrical Characteristics

PARAMETER	SYMBOL	V _{CC} (V)	CONDITIONS	Ta=25°C			Ta=-40~85°C		UNITS			
				MIN	TYP	MAX	MIN	MAX				
Input Voltage	VIH	2.0		1.5	-	-	1.5	-	V			
		3.0		2.1	-	-	2.1	-				
		5.5		3.85	-	-	3.85	-				
	VIL	2.0		-	-	0.5	-	0.5	V			
		3.0		-	-	0.9	-	0.9				
		5.5		-	-	1.65	-	1.65				
Output Voltage	VOH	2.0	VIN=VIH	I _{OH} =-50 μA	1.9	2.0	-	1.9	-	V		
					3.0	2.9	3.0	-	2.9		-	
					4.5	4.4	4.5	-	4.4		-	
		3.0		I _{OH} =-4mA	2.58	-	-	2.48	-			
		4.5		I _{OH} =-8mA	3.94	-	-	3.80	-			
	VOL	2.0	VIN=VIL	I _{OL} =50 μA	-	-	0.1	-	0.1	V		
					3.0	-	-	0.1	-		0.1	
					4.5	-	-	0.1	-		0.1	
					3.0	I _{OL} =4mA	-	-	0.36		-	0.44
					4.5	I _{OL} =8mA	-	-	0.36		-	0.44
Input Current	I _{IN}	0~5.5	VIN=VCC or GND	-0.1	-	0.1	-1	1	μA			
Quiescent Supply Current	I _{CC}	5.5	VIN=VCC or GND, I _{OUT} =0 μA	-	-	1.0	-	10.0	μA			

Switching Electrical Characteristics

(tr=tf=3ns)

PARAMETER	SYMBOL	CONDITIONS		Ta=25°C			Ta=-40~85°C		UNITS	
		CL	VCC(V)	MIN	TYP	MAX	MIN	MAX		
Propagation Delay Time (CK-Q, \bar{Q})	tPLH	15pF	3.3	—	6.7	11.9	1	14	ns	
			5.0	—	4.6	7.3	1	8.5		
		50pF	3.3	—	9.2	15.4	1	17.5	ns	
			5.0	—	6.1	9.3	1	10.5		
	tPHL	15pF	3.3	—	6.7	11.9	1	14	ns	
			5.0	—	4.6	7.3	1	8.5		
		50pF	3.3	—	9.2	15.4	1	17.5	ns	
			5.0	—	6.1	9.3	1	10.5		
Propagation Delay Time (\overline{PR} , \overline{CLR} -Q, \bar{Q})	tPLH	15pF	3.3	—	7.6	12.3	1	14.5	ns	
			5.0	—	4.8	7.7	1	9		
		50pF	3.3	—	10.1	15.8	1	18	ns	
			5.0	—	6.3	9.7	1	11		
	tPHL	15pF	3.3	—	7.6	12.3	1	14.5	ns	
			5.0	—	4.8	7.7	1	9		
		50pF	3.3	—	10.1	15.8	1	18	ns	
			5.0	—	6.3	9.7	1	11		
Minimum Set Up Time	ts(L)	—	3.3	6	—	—	7	—	ns	
	ts(H)	—	5.0	5	—	—	5	—		
Minimum Hold Time	th(L)	—	3.3	2	—	—	2	—	ns	
	th(H)	—	5.0	2	—	—	2	—		
Minimum Pulse Width (CK)	tw(L)	—	3.3	7	—	—	7	—	ns	
	tw(H)	—	5.0	5	—	—	5	—		
Minimum Pulse Width (\overline{PR} , \overline{CLR})	tw	—	3.3	7	—	—	7	—	ns	
		—	5.0	5	—	—	5	—		
Minimum Removal Time (\overline{PR} , \overline{CLR})	trem	—	3.3	5	—	—	5	—	ns	
		—	5.0	3	—	—	3	—		
Maximum Clock Frequency	fmax	15pF	3.3	80	125	—	70	—	MHz	
			5.0	130	170	—	110	—		
	50pF	3.3	50	75	—	45	—	MHz		
		5.0	90	115	—	75	—			
Input Capacitance	CIN	—	5.0	VIN=VCC or GND	—	4	10.0	—	10.0	pF
Power Dissipation Capacitance	Cpd	No Load, f=1MHz			—	9.3	—	—	—	pF

Noise Characteristics

(tr=tf=3ns)

PARAMETER	SYMBOL	CONDITIONS		Ta=25°C			UNITS
		CL	VCC(V)	MIN	TYP	MAX	
Not functioning output maximum dynamic VOL	VOLP	50pF	5.0	—	0.3	0.8	V
Not functioning output minimum dynamic VOL	VOLV	50pF	5.0	-0.8	-0.3	—	V
Minimum dynamic VIH	VIHD	50pF	5.0	—	—	3.5	V
Maximum dynamic VIL	VILD	50pF	5.0	—	—	1.5	V

Typical Application Circuit

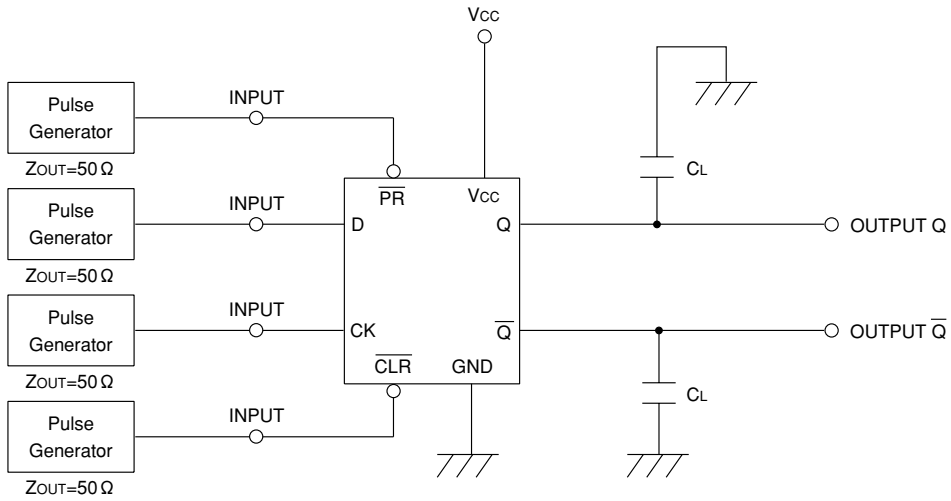

Notes: Vout=open when measuring supply current

Waveforms

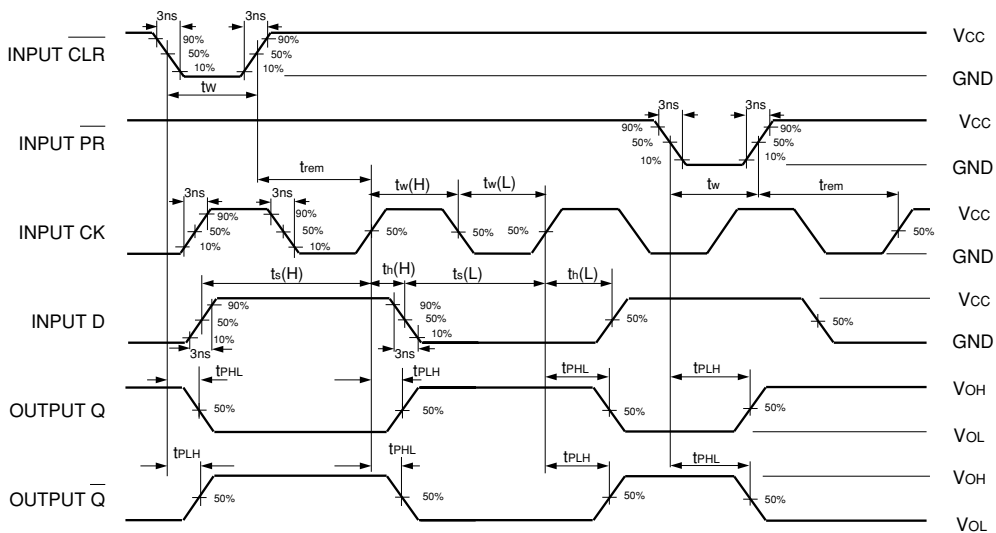

Notes: 1. Input Clock Frequency: 10MHz
2. D Input Frequency: 5MHz