



Z89319

DIGITAL TELEVISION CONTROLLER IN-CIRCUIT EMULATOR (ICE) DEVICE

FEATURES

- | | | | | |
|------------------------------------|--------------------------|--------------------------|----------------------------|--|
| ■ Part Number
Z89319 | ■ ROM (Word)
0 | ■ RAM (Word)
0 | ■ Speed (MHz)
12 | ■ Direct Closed Caption Decoding |
| ■ 124-Pin Grid Array (PGA) Package | | | | ■ TV Tuner Serial Interface |
| ■ 4.5- to 5.5-Volt Operating Range | | | | ■ Customized Character Set |
| ■ Z89C00 RISC Processor Core | | | | ■ Character Control Mode |
| ■ 0°C to +70°C Temperature Range | | | | ■ Directly Controlled Receiver Functions |

GENERAL DESCRIPTION

The Z89319 is a ROMless ICE chip version of the Z89300 family of Zilog's Digital Television Controllers designed for use in emulators and development boards to provide complete audio and video control of television receivers, video recorders, and advanced on-screen display facilities.

The powerful Z89C00 RISC processor core allows users to control on-board peripheral functions and registers using the standard processor instruction set.

In closed caption mode, text can be decoded directly from the composite video signal and displayed on the screen with assistance from the processor's digital signal processing capabilities. The character representation in this mode allows for a simple attribute control through the insertion of control characters.

The character control mode provides access to the full set of attribute controls. The modification of attributes is allowed on a character-by-character basis. The insertion of control characters permits direction of other character attributes.

Display attributes, including underlining, italics, blinking, eight foreground/background colors, character position offset delay, and background transparency, are made possible through a fully customized 512 character set, formatted in two 256 character banks.

Serial interfacing with the television tuner is provided through the tuner serial port. Digital channel tuning adjustments may be accessed through the industry-standard I²C port.

Additional hardware provides the capability to display two to three times normal size characters. The smoothing logic contained in the on-screen display circuit improves the appearance of larger fonts. Special circuitry can be activated to improve the visibility of text by adding a right-sided shadow effect to the characters.

Receiver functions such as color and volume can be directly controlled by six 8-bit pulse width modulated ports.

Notes:
All Signals with a preceding front slash, "/", are active Low, e.g.: B//W (WORD is active Low); /B/W (BYTE is active Low, only).

Power connections follow conventional descriptions below:

Connection	Circuit	Device
Power Ground	V _{CC} GND	V _{DD} V _{SS}

GENERAL DESCRIPTION (Continued)

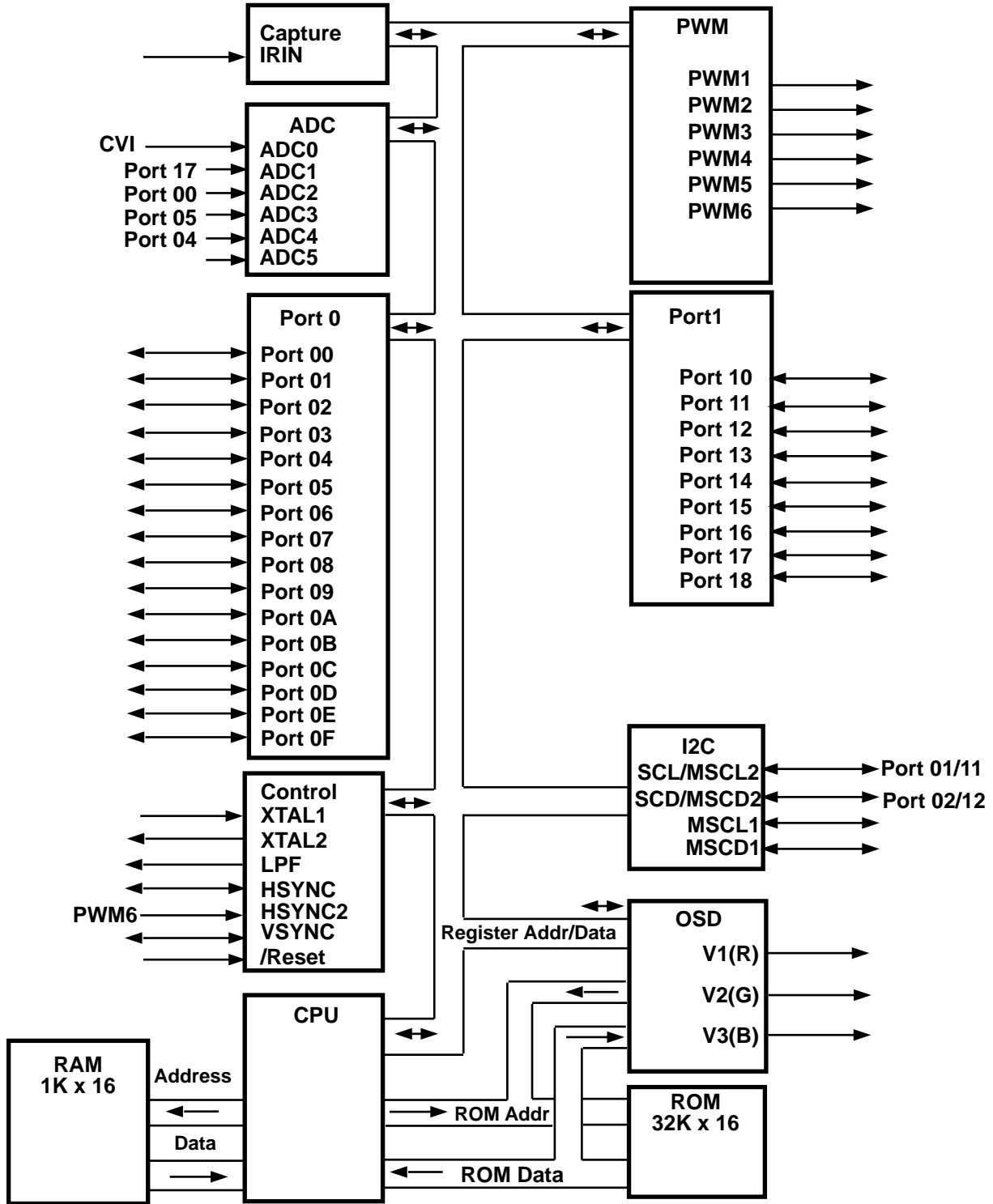

Functional Block Diagram

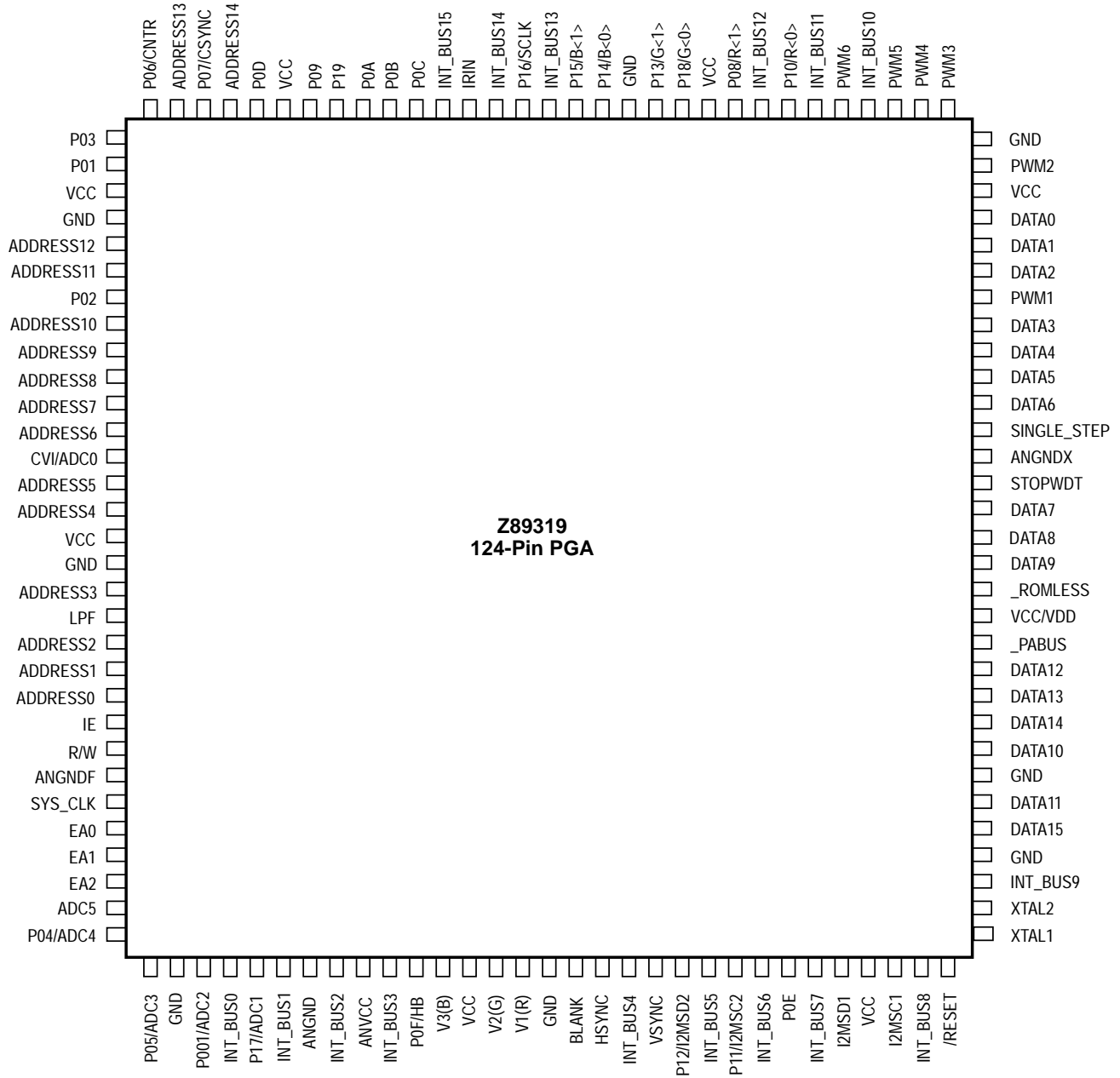

124-Pin PGA Configuration

PIN DESCRIPTION

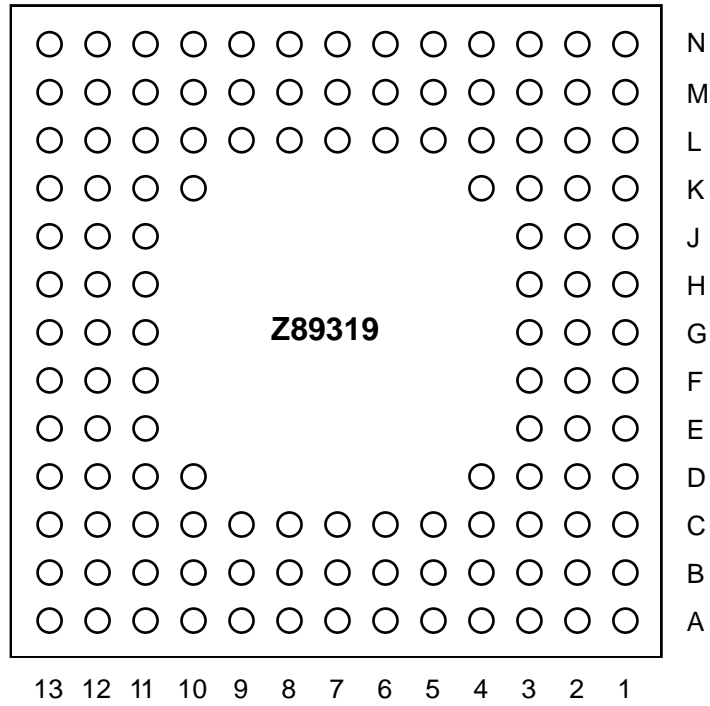

124-Pin PGA Configuration

V1, V2, V3 ANALOG OUTPUT

Specifications $V_{CC} = 5.25\text{ V}$

$V_{CC} = 5.25\text{ V}$	Condition	Limit
Output Voltage	Bit = 11	$4.30\text{ V} \pm 0.3\text{ V}$
	Bit = 10	$3.10\text{ V} \pm 0.25\text{ V}$
	Bit = 01	$1.90\text{ V} \pm 0.20\text{ V}$
	Bit = 00	$0\text{ V} \pm 0.75\text{ V}$
Setting Time	70% of DC Level, 10pf Load	< 50 ns

V1, V2, V3 ANALOG OUTPUT

Specifications $V_{CC} = 4.75\text{ V}$

$V_{CC} = 4.75\text{ V}$	Condition	Limit
Output Voltage	Bit = 11	$3.90\text{ V} \pm 0.30\text{ V}$
	Bit = 10	$2.80\text{ V} \pm 0.25\text{ V}$
	Bit = 01	$1.70\text{ V} \pm 0.20\text{ V}$
	Bit = 00	$0\text{ V} \pm 0.65\text{ V}$
Setting Time	70% of DC Level, 10pf Load	< 50 ns

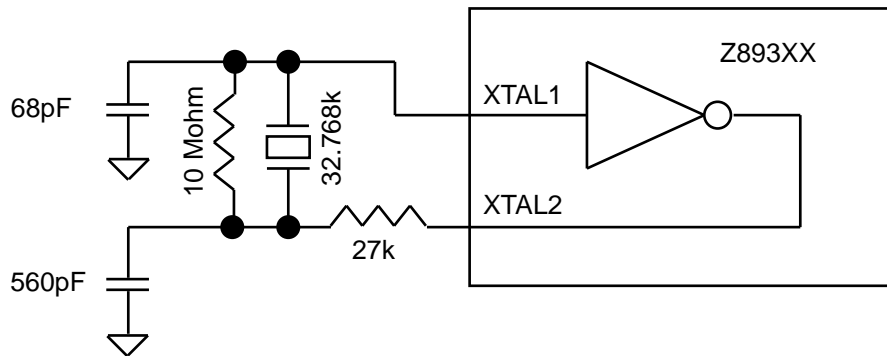

32K Oscillator Recommended Circuit

ABSOLUTE MAXIMUM RATINGS

Symbol	Parameter	Min	Max	Units	Conditions
V_{CC}	Power Supply Voltage	0	7	V	
V_{ID}	Input Voltage	-0.3	$V_{CC} + 0.3$	V	Digital Inputs
V_{IA}	Input Voltage	-0.3	$V_{CC} + 0.3$	V	Analog Inputs (A/D0...A/D4)
V_O	Output Voltage	-0.3	$V_{CC} + 0.3$	V	All Push-Pull Digital Output
I_{OH}	Output Current High		-10/-1 ^a	mA	One Pin
I_{OH}	Output Current High		-100	mA	All Pins
I_{OL}	Output Current Low		20/1 ^b	mA	One Pin
I_{OL}	Output Current Low		200	mA	All Pins
T_A	Operating Temperature	0	70	°C	
T_A	Storage Temperature	-65	150	°C	

Notes:

- a) 1 mA max. when output pad impedance is 600 Ω .
 b) 1 mA max. when output pad impedance is 600 Ω .

DC CHARACTERISTICS

$T_A = 0^\circ\text{C}$ to $+70^\circ\text{C}$; $V_{CC} = 4.5\text{ V}$ to $+5.5\text{ V}$; $F_{OSC} = 32.768\text{ KHz}$

Symbol	Parameter	Min	Max	Typical	Units	Conditions
V_{IL}	Input Voltage Low	0	$0.2 V_{CC}$	0.4	V	
V_{IH}	Input Voltage High	$0.6 V_{CC}$	V_{CC}	3.6	V	
V_{OL}	Output Voltage Low		0.4	0.16	V	@ $I_{OL} = 1\text{ mA}$
V_{OH}	Output Voltage High	$V_{CC} - 0.9$		4.75	V	@ $I_{OL} = 0.75\text{ mA}$
V_{XL}	Input Voltage XTAL1 Low		$0.3 V_{CC}$	1.0	V	External Clock
V_{XH}	Input Voltage XTAL1 High	$V_{CC} - 2.0$		3.5	V	Generator Driven
V_{HY}	Schmitt Hysteresis	3.0	0.75	0.5	V	On XTAL1 Input Pin
I_{IR}	Reset Input Current		150	90	μA	$V_{RL} = 0\text{ V}$
I_{IL}	Input Leakage	-3.0	3.0	0.01	μA	@ 0 V and V_{CC}
I_{CC}	Supply Current		100	60	mA	
I_{CC1}	Supply Current		300	100	μA	Sleep Mode @ 32 KHz
I_{CC2}	Supply Current		40	5	μA	Stop Mode

AC CHARACTERISTICS

$T_A = 0^\circ\text{C to } +70^\circ\text{C}; V_{CC} = 4.5 \text{ V to } 5.5 \text{ V}; F_{OSC} = 32.768 \text{ KHz}$

Symbol	Parameter	Min	Max	Typical	Units	Note
T_{PC}	Input Clock Period	16	100	32	μS	
T_{RC}, T_{FC}	Clock Input Rise and Fall			12	μS	
T_{DPOR}	Power On Reset Delay	0.8		1.2	s	Depends on Crystal

AC CHARACTERISTICS*

$T_A = 0^\circ\text{C to } +70^\circ\text{C}; V_{CC} = 4.5 \text{ V to } 5.5 \text{ V}; F_{OSC} = 32.768 \text{ KHz}$

Symbol	Parameter	Min	Max	Typical	Units
T_{WRES}	Power-On Reset Min. Width		5TPC		μS
T_{DH_S}	H_Sync Incoming Signal Width	5.5	12.5	11	μS
T_{DV_S}	V_Sync Incoming Signal Width	0.15	1.5	1.0	mS
T_{DE_S}	Time Delay Between Leading Edge of V_Sync and H_Sync in Even Field	-12	+12	0	μS
T_{DO_S}	Time Delay Between Leading Edge of H_Sync in Odd Field	20	44	32	μS
T_{WHV_S}	H_Sync/V_Sync Edge Width		2.0	0.5	μS

Notes:

All timing of the I²C bus interface are defined by related specifications of the I²C bus interface.