

November 2004

Features

- Conforms to EBU specification for DVB-S and DirecTV specification for DSS
- On-chip digital filtering supports 1 - 45 MSps symbol rates
- On-chip 60 or 90 MHz dual-ADC
- High speed scanning mode for blind symbol rate/code rate acquisition
- Automatic spectral inversion resolution
- High level software interface for minimum development time
- Up to ± 22.5 MHz LNB frequency tracking
- DiSEqC™ v2.2: receive/transmit for full control of LNB, dish and other components
- Compact 64-pin LQFP package (7 x 7 mm)
- A full DVB-S front-end reference design is available, ref. ZLE10538

Applications

- DVB 1 - 45 MSps compliant satellite receivers
- DSS 20 MSps compliant satellite receivers
- SMATV (Single Master Antenna TV) trans-modulators
- Satellite PC applications

Ordering Information

ZL10313QCG	64 Pin LQFP	Trays, Bake & Drypack
ZL10313QCG1	64 Pin LQFP*	Trays, Bake & Drypack
ZL10313UBH	Die supplied in wafer form**	

*Pb Free Matte Tin

**Please contact Sales for further details

0°C to +70°C

Description

The ZL10313 is a QPSK/BPSK 1 - 45 MSps demodulator and channel decoder for digital satellite television transmissions to the European Broadcast Union ETS 300 421 specification. It receives analogue I and Q signals from the tuner, digitises and digitally demodulates this signal, implements the complete DVB/DSS FEC (Forward Error Correction) and de-scrambling function. The output is in the form of MPEG2 or DSS transport stream data packets. The ZL10313 also provides automatic gain control to the RF front-end device.

The ZL10313 has a serial 2-wire bus interface to the control microprocessor. Minimal software is required to control the ZL10313 because of the built in automatic search and decode control functions.

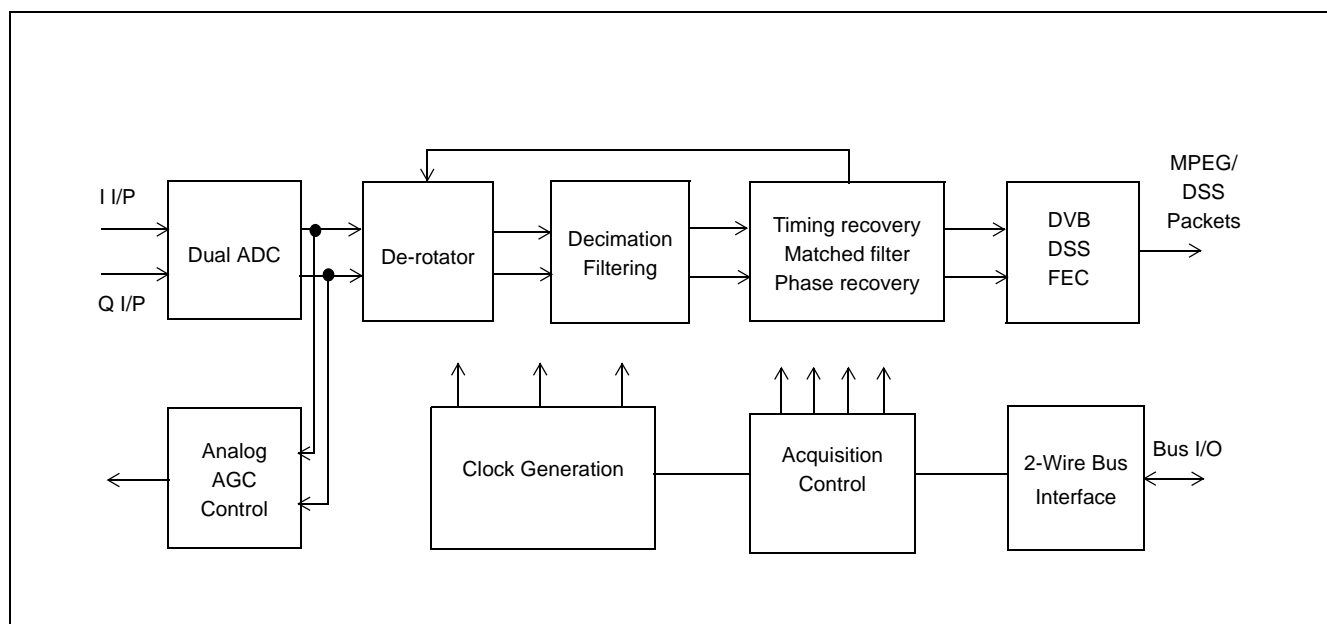

Figure 1 - Functional Block Diagram

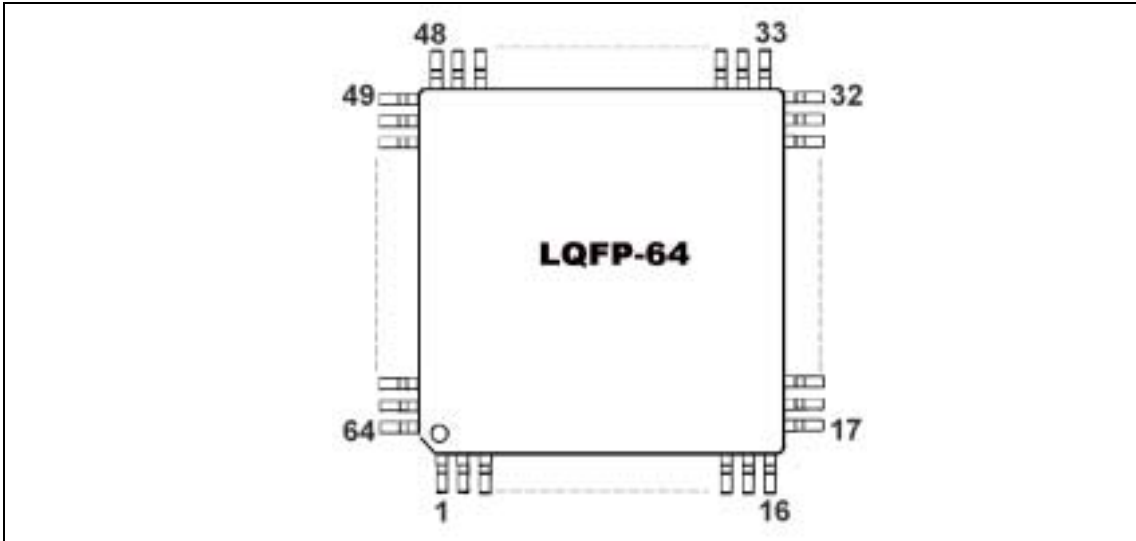

Figure 2 - ZL10313 Pin Allocation

Pin Table

No.	Name	No.	Name	No.	Name	No.	Name
1	$\overline{\text{Reset}}$	17	CVdd	33	Gnd	49	MDO[1]
2	DiSEqC[2] ¹	18	Gnd	34	CVdd	50	CVdd
3	DiSEqC[1]	19	$\overline{\text{XTI}}$	35	Addr[1]	51	Gnd
4	DiSEqC[0]	20	XTO	36	Addr[2]	52	MDO[2]
5	Vdd	21	Gnd	37	Addr[3]	53	MDO[3]
6	Gnd	22	CVdd	38	Addr[4]	54	Gnd
7	CVdd	23	Gnd	39	Vdd	55	Vdd
8	Gnd	24	lin	40	Gnd	56	MDO[4]
9	Sleep	25	$\overline{\text{lin}}$	41	AGC	57	MDO[5]
10	CLK1	26	Gnd	42	Test	58	Gnd
11	DATA1	27	Vdd	43	$\overline{\text{IRQ}}$ ¹	59	CVdd
12	CVdd	28	Gnd	44	CVdd	60	MDO[6]
13	Gnd	29	$\overline{\text{Qin}}$	45	Gnd	61	MDO[7]
14	DATA2	30	Qin	46	MOSTRT	62	MOCLK
15	CLK2	31	Gnd	47	MOVAL	63	$\overline{\text{BKERR}}$
16	OscMode	32	CVdd	48	MDO[0]	64	Status

1. Can be programmed to be MICKL (MPEG input clock) instead.

Notes: All supply pins **must** be connected as they are not all commoned internally.

Table of Contents

1.0 Application Diagram	7
2.0 Functional Overview	8
2.1 Introduction	8
2.2 Analogue-to-Digital Converter	8
2.3 QPSK Demodulator	8
2.4 Forward Error Correction	9
2.4.1 Viterbi Error Count Measurement	9
2.4.1.1 Viterbi Error Count Coarse Indication	10
2.4.2 The Frame Alignment Block	11
2.4.3 The De-Interleaver Block	11
2.4.3.1 DVB	11
2.4.3.2 DSS	12
2.4.4 The Reed-Solomon Decoder Block	13
2.4.5 The Energy Dispersal (de-scrambler) Block, DVB Only	14
2.4.6 Output Stage	14
2.5 Control	14
2.5.1 Symbol Rate and Code Rate Search Mode	15
2.6 DiSEqC Transmit and Receive Messages	15
2.6.1 DiSEqC Transmitting Messages	15
2.6.2 DiSEqC Receiving Messages	16
3.0 Microprocessor Control	16
3.1 RADD: 2-wire Register Address (W)	16
3.2 Primary 2-wire Bus Interface	17
3.3 Secondary 2-wire Bus for Tuner Control	18
4.0 Electrical Characteristics	18
4.1 Recommended Operating Conditions	18
4.2 Absolute Maximum Ratings	18
4.3 Primary 2-Wire Bus Timing	19
4.4 Crystal Specification	20
4.5 Electrical Characteristics	20
4.6 ZL10313 Pinout Description	22
4.7 Alphabetical Listing of Pin-Out	24
5.0 References	24
6.0 Trademarks	24

List of Figures

Figure 1 - Functional Block Diagram	1
Figure 2 - ZL10313 Pin Allocation	2
Figure 3 - ZL10313 Functional Block Diagram	5
Figure 4 - Typical Application Schematic	7
Figure 5 - Viterbi Block Diagram	9
Figure 6 - Viterbi Error Count Measurement	10
Figure 7 - Viterbi Error Count Coarse Indication	11
Figure 8 - DVB Conceptual Diagram of the Convolutional De-Interleaver Block	12
Figure 9 - DSS Conceptual Diagram of the Convolutional De-Interleaver Block	12
Figure 10 - DVB Block Structure	13
Figure 11 - DVB Energy Dispersal Conceptual Diagram	13
Figure 12 - DVB Energy Dispersal Conceptual Diagram	14
Figure 13 - ZL10313 Control Structure	15
Figure 14 - Primary 2-Wire Bus Timing	19
Figure 15 - Crystal Oscillator Circuit	20

Overview

The ZL10313 is a QPSK/BPSK 1 - 45 MSps demodulator and channel decoder for digital satellite television transmissions compliant to both DVB-S and DSS standards and other systems, such as LMDS, that use the same architecture.

A Command Driven Control (CDC) system is provided making the ZL10313 very simple to program. After the tuner has been programmed to the required frequency to acquire a DVB transmission, the ZL10313 requires a minimum of five registers to be written.

The ZL10313 provides a monitor of bit error rate after the QPSK module and also after the Viterbi module. For receiver installation, a high speed scan or 'blind search' mode is available. This allows all signals from a given satellite to be evaluated for frequency, symbol rate and convolutional coding scheme. The phase of the IQ signals can be automatically determined.

Full DiSEqC is provided for both writing and reading DiSEqC messages. Storage in registers for up to eight data bytes sent and eight data bytes received is provided.

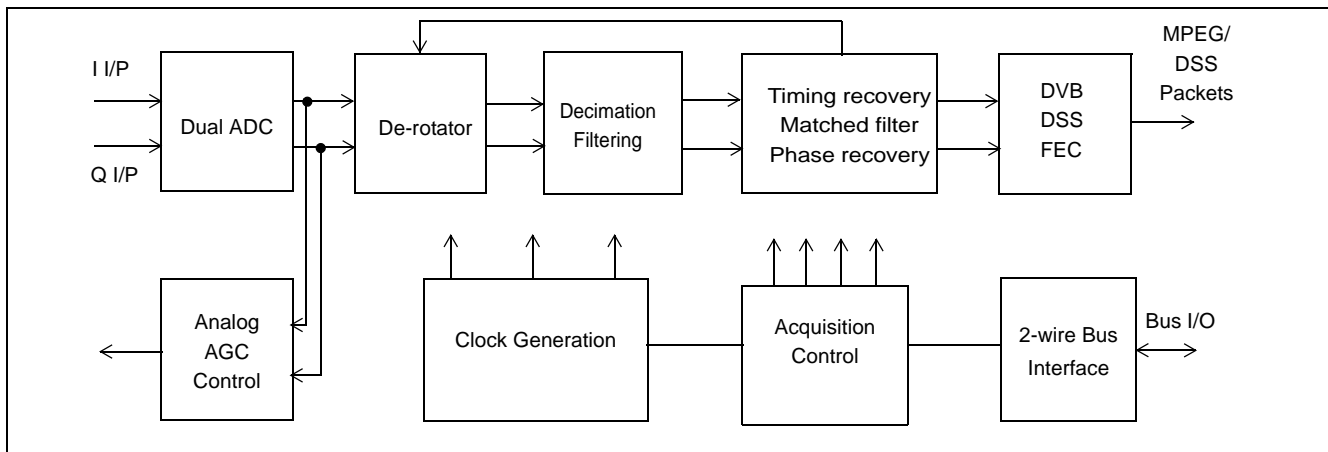

Figure 3 - ZL10313 Functional Block Diagram

Additional Features

- 2-wire bus microprocessor interface
- All-digital clock and carrier recovery
- On-chip PLL clock generation using a low cost 10 to 16 MHz crystal (or external clock)
- 3.3/1.8 V operation
- 64 pin LQFP package
- Low external component count
- Commercial temperature range 0 to 70°C
- External MPEG clock option

Demodulator

- BPSK or QPSK programmable
- Optional fast acquisition mode for low symbol rates

Viterbi

- Programmable decoder rates 1/2, 2/3, 3/4, 5/6, 6/7, 7/8
- Automatic spectrum resolution of IQ phase
- Constraint length $k = 7$
- Trace back depth 128
- Extensive SNR and BER monitors

De-Interleaver

- Compliant with DVB and DSS standards

Reed-Solomon

- (204, 188) for DVB and (146,130) for DSS
- Reed-Solomon bit-error-rate monitor to indicate Viterbi performance

De-Scrambler

- EBU specification de-scrambler for DVB mode

Outputs

- MPEG transport parallel & serial output
- Three output clocking modes for maximum flexibility
- Integrated MPEG2 TEI bit processing for DVB only

Application Support

- Windows based evaluation software
- ANSI-C compliant software
- A full DVB-S front-end satellite tuner reference design kit is available for evaluation, based on the schematic below (Figure 4). Zarlink reference ZLE10538

1.0 Application Diagram

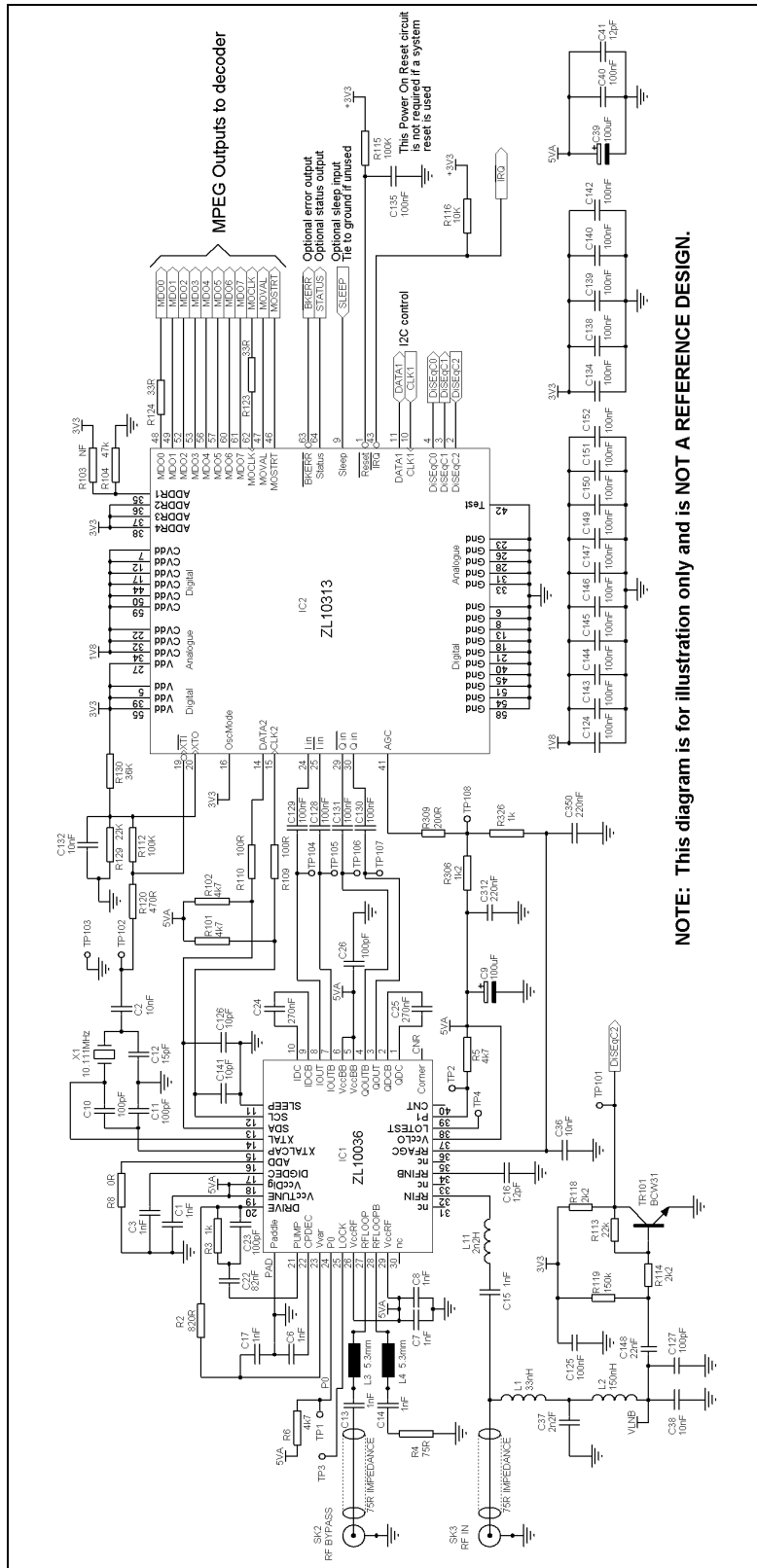

Figure 4 - Typical Application Schematic

2.0 Functional Overview

2.1 Introduction

ZL10313 is a single-chip variable rate digital QPSK/BPSK satellite demodulator and channel decoder. The ZL10313 accepts base-band in-phase and quadrature analogue signals and delivers an MPEG or DSS packet data stream. Digital filtering in ZL10313 removes the need for programmable external anti-alias filtering for all symbol rates from 1 - 45 MSps. Frequency, timing and carrier phase recovery are all digital and the only feed-back to the analogue front-end is for automatic gain control. The digital phase recovery loop enables very fine bandwidth control that is needed to overcome performance degradation due to phase and thermal noise.

All acquisition algorithms are built into the ZL10313 controller. The ZL10313 can be operated in a Command Driven Control (CDC) mode by specifying the symbol rate and Viterbi code rate. There is also a provision for a search for unknown symbol rates and Viterbi code rates.

2.2 Analogue-to-Digital Converter

The A/D converters sample single-ended or differential analogue inputs and consist of a dual ADC and circuitry to provide improved SiNaD (Signal-Noise and Distortion) and channel matching.

The fixed rate sampling clock is provided on-chip using a programmable PLL needing only a low cost 10 to 16 MHz crystal. Different crystal frequencies can be combined with different PLL ratios, depending on the maximum symbol rate, allowing a very flexible approach to clock generation. An external clock signal in the range 4 to 16 MHz can also be used as the master clock.

2.3 QPSK Demodulator

The demodulator in the ZL10313 consists of signal amplitude offset compensation, frequency offset compensation, decimation filtering, carrier recovery, symbol recovery and matched filtering. The decimation filters give continuous operation from 2 Mbps to 90 Mbps allowing one receiver to cover the needs of the consumer market as well as the single carrier per channel (SCPC) market with the same components without compromising performance, that is, the channel reception is within 0.5 dB from theory. For a given symbol rate, control algorithms on the chip detect the number of decimation stages needed and switch them in automatically.

The frequency offset compensation circuitry is capable of tracking out up to ± 22.5 MHz frequency offset. This allows the system to cope with relatively large frequency uncertainties introduced by the Low Noise Block (LNB). Full control of the LNB is provided by the DiSEqC outputs from the ZL10313. Horizontal/vertical polarization and an instruction modulated 22 kHz signal are available under register control. All DiSEqC functions are implemented on the ZL10313. An internal state machine that handles all the demodulator functions controls the signal tracking and acquisition. Various preset modes are available as well as blind acquisition where the receiver has no prior knowledge of the received signal. Fast acquisition algorithms have been provided for low symbol rate applications. Full interactive control of the acquisition function is possible for debug purposes. In the event of a signal fade or a cycle slip, the QPSK demodulator allows sufficient time for the FEC to reacquire lock, for example, via a phase rotation in the Viterbi decoder. This is to minimize the loss of signal due to the signal fade. Only if the FEC fails to re-acquire lock for a long period (which is programmable) the QPSK will try to re-acquire the signal.

The matched filter is a root-raised-cosine filter with either 0.20 or 0.35 roll-off, compliant with DSS and DVB standards. Although not a part of the DVB standard, ZL10313 allows a roll-off of 0.20 to be used with other DVB parameters. An AGC signal is provided to control the signal levels in the tuner section of the receiver and ensure the signal level fed to the ZL10313 is set at an optimal value under all reception conditions.

The ZL10313 provides comprehensive information on the input signal and the state of the various parts of the device. This information includes signal to noise ratio (SNR), signal level, AGC lock, timing and carrier lock signals. A maskable interrupt output is available to inform the host controller when events occur.

2.4 Forward Error Correction

The ZL10313 contains FEC blocks to enable error correction for DVB-S and DSS transmissions. The Viterbi decoder block can decode the convolutional code with rates 1/2, 2/3, 3/4, 5/6, 6/7 or 7/8. The block features automatic synchronization, automatic spectral inversion resolution and automatic code rate detection. The trace back depth of 128 provides better performance at high code rates and the built-in synchronization algorithm allows the Viterbi decoder to lock onto signals with very poor signal-to-noise ratios. A Viterbi bit error rate monitor provides an indication of the error rate at the QPSK output.

The 24-bit error count register in the Viterbi decoder allows the bit error rate at the output of the QPSK demodulator to be monitored. The 24-bit bit error count register in the Reed-Solomon decoder allows the Viterbi output bit error rate to be monitored. The 16-bit uncorrectable packet counter yields information about the output packet error rate. These three monitors and the QPSK SNR register allow the performance of the device and its individual components, such as the QPSK demodulator and the Viterbi decoder, to be monitored extensively by the external microprocessor. The frame/byte align block features a sophisticated synchronization algorithm to ensure reliable recovery of DVB and DSS framed data streams under worst case signal conditions. The de-interleaver uses on-chip RAM and is compatible with the DVB and DSS algorithms. The Reed-Solomon decoder is a truncated version of the (255, 239) code. The code block size is 204 for DVB and 146 for DSS. The decoder provides a count of the number of uncorrectable blocks as well as the number of bit errors corrected. The latter gives an indication of the bit error rate at the output of the Viterbi decoder. In DVB mode, spectrum de-scrambling is performed compatible with the DVB specification. The final output is a parallel or serial transport data stream, packet sync, data clock and a block error signal. The data clock may be inverted under software control.

2.4.1 Viterbi Error Count Measurement

A method of estimating the bit error rate at the output of the QPSK block has been provided in the Viterbi decoder. The incoming data bit stream is delayed and compared with the re-encoded and punctured version of the decoded bit stream to obtain a count of errors, see Figure 5. The measurement system has a programmable register to determine the number of data bits (the error count period) over which the count is being recorded. A read register indicates the error count result and an interrupt can be generated to inform the host microprocessor that a new count is available.

The VIT_ERRPER_register is programmed with the required number of data bits (the error count period) (VIT_ERRPER[7:0]). The count of errors found during this period is loaded by the ZL10313 into the VIT_ERRCNT_H-M-L trio of registers when the bit count VIT_ERRPER[7:0] is reached. At the same time an interrupt is generated on the $\overline{\text{IRQ}}$ line. Setting the IE_FEC[2] bit in the IE_FEC register enables the interrupt. Reading the register does not clear VIT_ERRCNT [23:0], it is only loaded with the error count.

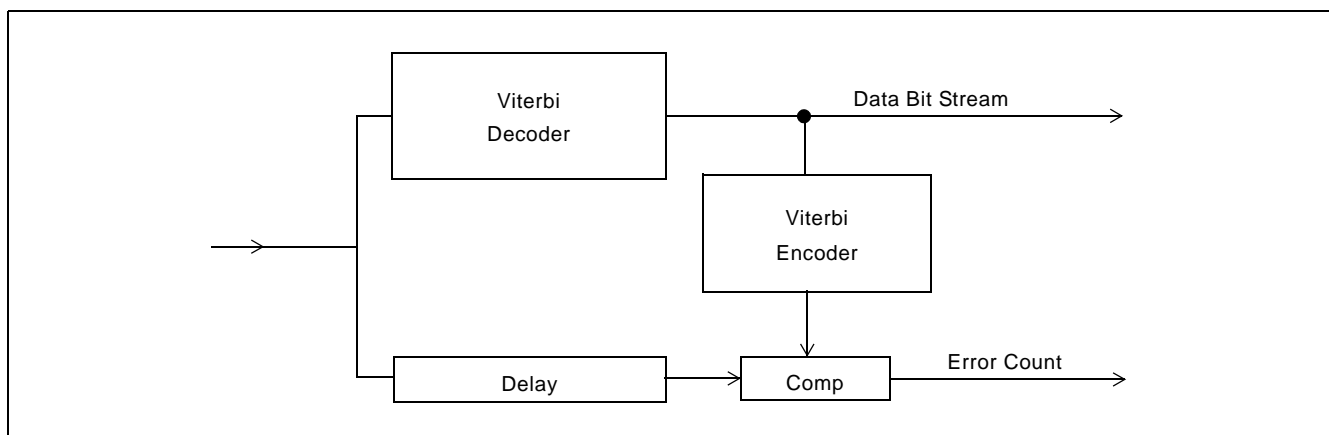

Figure 5 - Viterbi Block Diagram

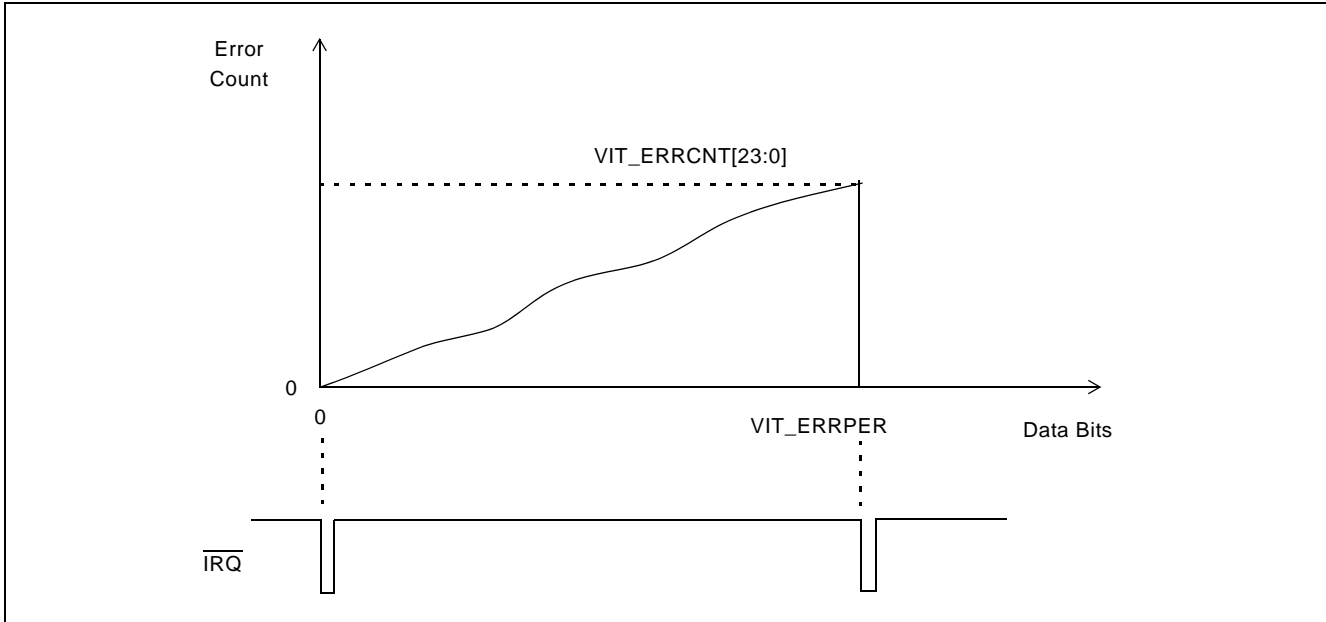

Figure 6 - Viterbi Error Count Measurement

Figure 6 shows the bit errors rising until the maximum programmed value of VIT_ERRPER is reached, when an interrupt is generated on the $\overline{\text{IRQ}}$ line to advise the host microprocessor that a new value of bit error count has been loaded into the VIT_ERRCNT [23:0] register. The $\overline{\text{IRQ}}$ line will go high when the IE_FEC register is read by the host microprocessor. The error count may be expressed as a ratio:

$$\frac{\text{VIT_ERRCNT}[23:0]}{\text{VIT_ERRPER}[7:0] * 262144}$$

2.4.1.1 Viterbi Error Count Coarse Indication

To assist in the process of aligning the receiver dish aerial, a coarse indication of the number of bit errors being received can be provided by monitoring the STATUS line with the following set up conditions.

The frequency of the output waveform will be a function of the bit error count (triggering the maximum value programmed into the VIT_MAXERR[7:0] register and the dish alignment on the satellite. This VIT_MAXERR mode is enabled by setting the FEC_STAT_EN register bit-0. Figure 7 shows the bit errors rising to the maximum value programmed and triggering a change of state on the STATUS line.

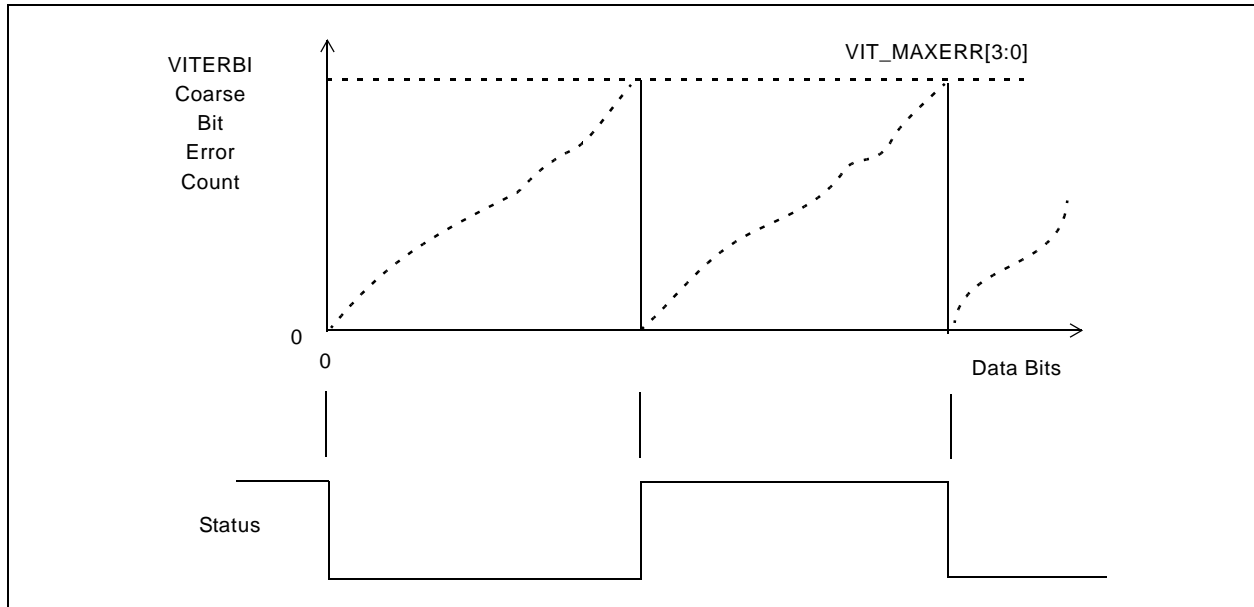

Figure 7 - Viterbi Error Count Coarse Indication

2.4.2 The Frame Alignment Block

The frame alignment algorithm detects a sequence of correctly spaced synchronizing bytes in the Viterbi decoded bit-stream and arranges the input into blocks of data bytes. Each block consists of 204 bytes for DVB and 147 bytes for DSS. In the DSS mode, the synchronizing byte is removed from the data stream, so only 146 bytes of a block are passed to the next stage. The frame alignment block also removes the 180° phase ambiguity not removed by the Viterbi decoder.

2.4.3 The De-Interleaver Block

2.4.3.1 DVB

Before transmission, the data bytes are interleaved with each other in a cyclic pattern of twelve. This ensures the bytes are spaced out to avoid the possibility of a noise spike corrupting a group of consecutive message bytes. Figure 8 below shows conceptually how the convolutional de-interleaving system works. The synchronization byte is always loaded into the First-In-First-Out (FIFO) memory in branch 0. The switch is operated at regular byte intervals to insert successively received bytes into successive branches. After 12 bytes have been received, byte 13 is written next to the synchronization byte in branch 0, etc. In the ZL10313, this de-interleaving function is realized using on-chip Random Access Memory (RAM).

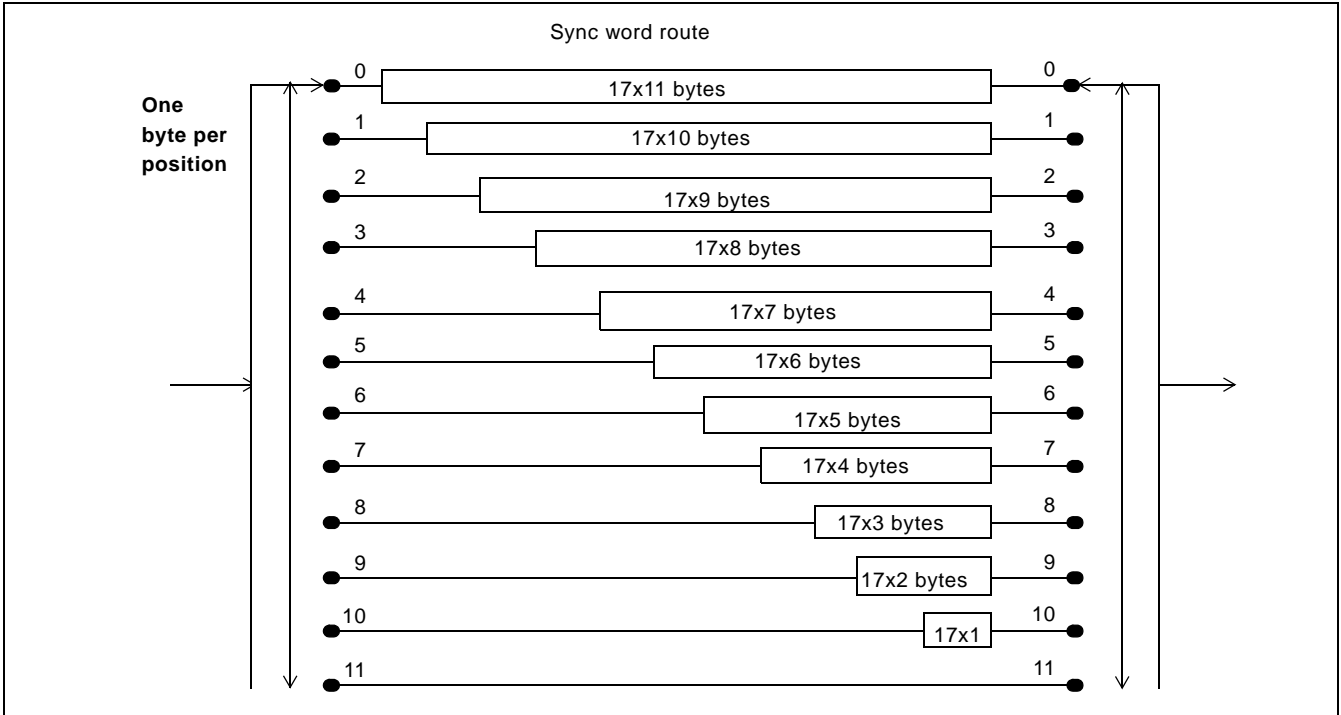

Figure 8 - DVB Conceptual Diagram of the Convolutional De-Interleaver Block

2.4.3.2 DSS

Before transmission, the data bytes are interleaved with each other in a cyclic pattern of thirteen. This ensures the bytes are spaced out to avoid the possibility of a noise spike corrupting a group of consecutive message bytes. Figure 9 below shows conceptually how the convolutional de-interleaving system works. On the ZL10313, this function is realized in the same Random Access Memory (RAM) as used for DVB, but utilizing a different addressing algorithm.

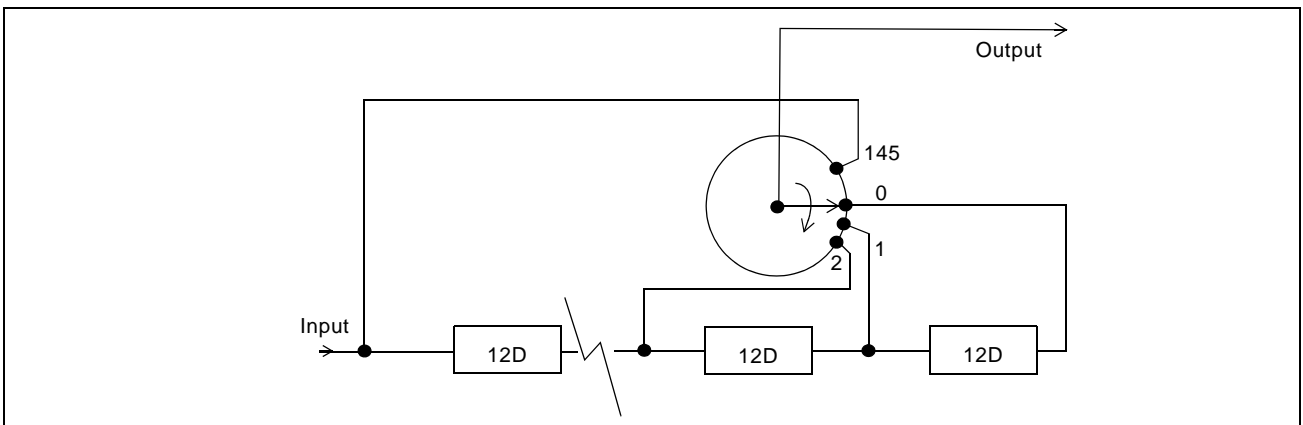

Figure 9 - DSS Conceptual Diagram of the Convolutional De-Interleaver Block

2.4.4 The Reed-Solomon Decoder Block

DVB and DSS data are encoded using shortened versions of the Reed-Solomon code of block length 255, containing 239 message bytes and 16 check bytes, that is (255,239) with $T = 8$. Both encoders use the same generator polynomial. The code block size for DVB is 204 and that for DSS is 146. Hence DVB code is (204, 188) and DSS code is (146, 130), with both having $T = 8$. The block structure of the DVB and DSS Reed-Solomon codes are as shown in Figure 10 and Figure 11 below.

The Reed-Solomon decoder can correct up to eight byte errors per packet. If there are more than eight bytes containing errors, the packet is flagged as uncorrectable using the BKERR pin 63. In the case of DVB the Transport Error Indicator (TEI) bit of the MPEG packet is set to 1, if setting of TEI is enabled.

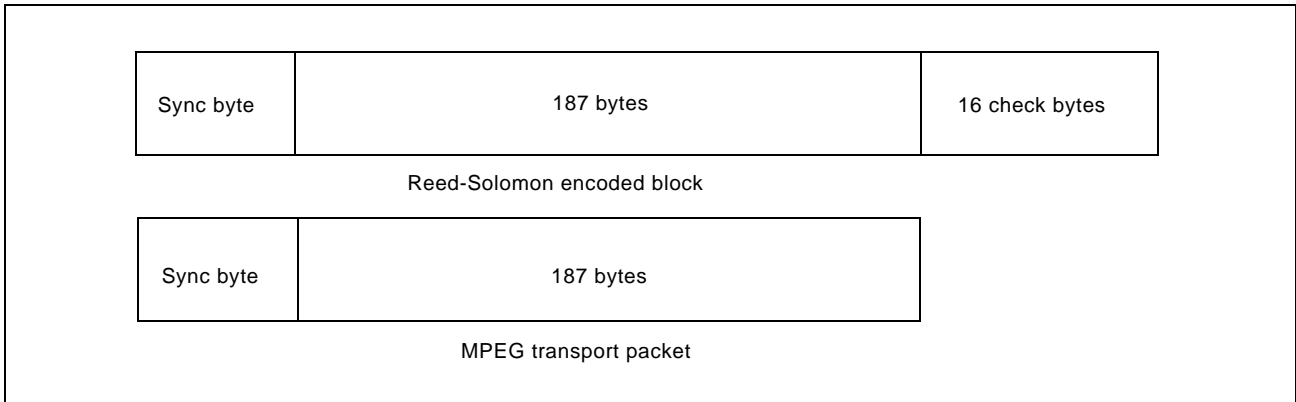

Figure 10 - DVB Block Structure

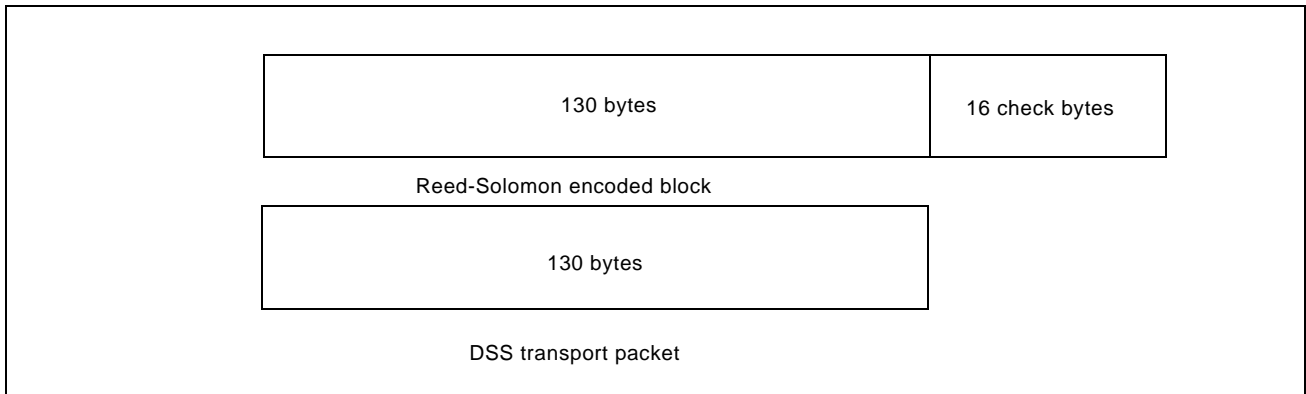

Figure 11 - DVB Energy Dispersal Conceptual Diagram

2.4.5 The Energy Dispersal (de-scrambler) Block, DVB Only

Before Reed-Solomon encoding in the DVB transmission system, the MPEG2 data stream is randomised using the configuration shown in Figure 12 below. This is a Pseudo Random Binary Sequence (PRBS) generator, with the polynomial:

$$1 + X^{14} + X^{15}$$

The PRBS registers are loaded with the initialisation sequence as shown, at the start of the first transport packet in a group of eight packets. This point is indicated by the inverted sync byte 0xB8 (the normal DVB sync byte is 0x47). The data starting with the first byte after the sync byte are randomised by exclusive-ORing data bits with the PRBS (the sync bytes themselves are not randomised). In the decoder, the process of de-randomising or de-scrambling the data is exactly the same as described above. The de-scrambler also inverts the sync byte 0xB8 so that all MPEG output packets have the same sync byte 0x47.

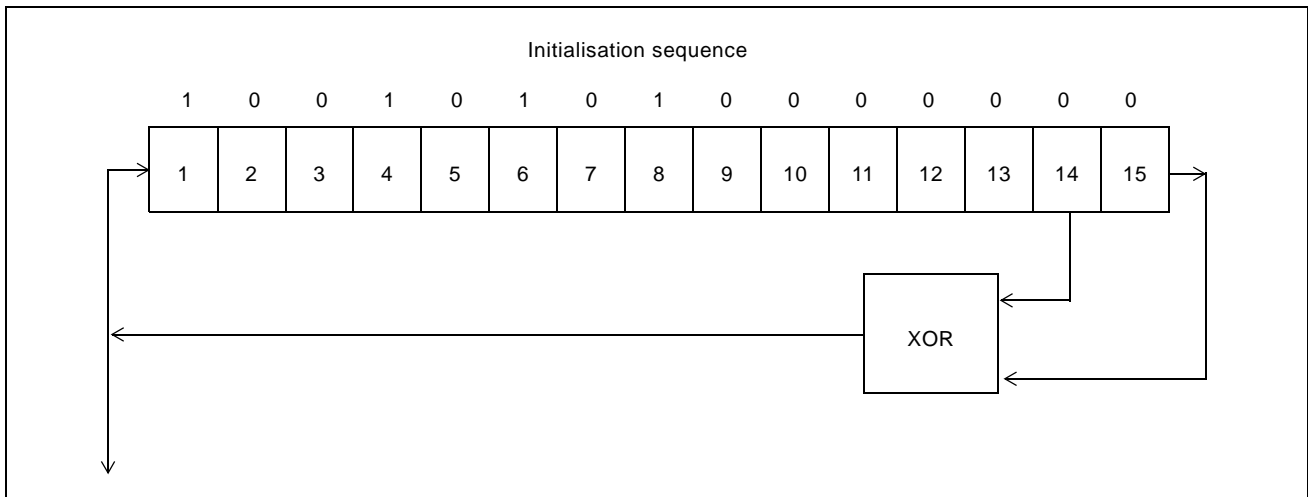

Figure 12 - DVB Energy Dispersal Conceptual Diagram

2.4.6 Output Stage

The transport stream can be output in a byte-parallel or bit-serial mode. The output interface consists of an 8-bit output, output clock, a packet validation level, a packet start pulse and a block error indicator.

The output clock rate depends on the symbol rate, QPSK/BPSK choice, convolutional (Viterbi) coding rate, DVB/DSS choice and byte-parallel or bit-serial output mode. This rate is computed by ZL10313 to be very close to the minimum required to output packet data without packet overlap. Furthermore, the packets at the output of ZL10313 are as evenly spaced as possible to minimize packet position movement in the transport layer. The maximum movement in the packet synchronization byte position is limited to ± 1 output clock period.

2.5 Control

Automatic symbol rate search, code rate search, signal acquisition and signal tracking algorithms are built into the ZL10313 using a sophisticated on-chip controller. The software interaction with the device is via a simple Command Driven Control (CDC) interface. This CDC maps high level inputs such as symbol rates in MSps and frequencies in MHz, to low level on-chip register settings. The on-chip control state machine and the CDC significantly reduces the software overhead as well as the channel search times. There is also an option for the host processor to by-pass both the CDC as well as the on-chip controller and take direct control of the QPSK demodulator. Once the ZL10313 has locked to the signal, any frequency offset can be read from the LNB_FREQ error registers 7 and 8. The frequency synthesiser under the software control can be re-tuned in frequency to optimise the received signal within the baseband filter bandwidth. Note that ZL10313 compensates for any frequency offsets before QPSK

demodulation. Hence a frequency offset will not necessarily lead to a performance loss. Performance loss will occur only if a significant part of the signal is cut off by the base-band filter, due to this frequency offset. This will happen only if the symbol rate is close to the maximum supported by that filter. In such an event it is recommended that front-end be re-tuned to neutralise this error before the filter. It is then necessary for the ZL10313 to re-acquire the signal.

The ZL10313 can generate control signals to enable full control of the dish and LNB. The chip implements the signals needed for the full DiSEqC specification. This includes high/low band selection, polarization and dish position. In this mode, the symbol rate in MSps and Viterbi code rate are the only values needed to start the ZL10313 searching for the signal. The CDC module maps the high level parameters into the various low level register settings needed to acquire and track the signal. The low level registers may be read and directly modified to suit very specific requirements. However, this is not recommended.

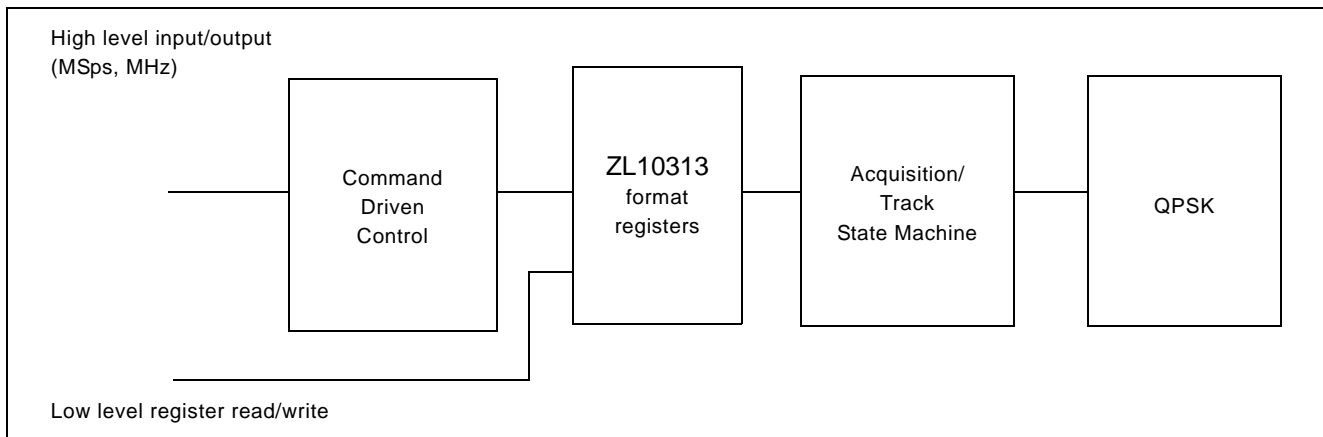

Figure 13 - ZL10313 Control Structure

2.5.1 Symbol Rate and Code Rate Search Mode

Where the symbol rate and/or the Viterbi code rate are unknown, the ZL10313 can be programmed to search for QPSK/BPSK signals. The user should define the range(s) over which the search is required. The ZL10313 will then locate and track any signal detected. Failure to find a QPSK signal in the specified frequency and specified symbol rate ranges will be indicated by interrupts. ZL10313 will carry on searching these ranges after issuing these interrupts. When the ZL10313 has locked onto a signal, the symbol rate in MSps may be read from the MONITOR registers. The Viterbi code rate may be read from the FEC_STATUS register. This search facility is primarily for use during the initial installation of a receiver.

2.6 DiSEqC Transmit and Receive Messages

The ZL10313 has the capability to send and receive DiSEqC messages. Eight registers are provided to store a message for transmission and a further eight registers are provided to store a received message. The received bytes have a parity bit and a parity error bit in addition to the eight data bits. These additional bits are read out in sequence following the data bits, so two byte reads are required for each data byte.

2.6.1 DiSEqC Transmitting Messages

The sequence of events to send a message are as follows:

1. Load the required message bytes into the DiSEqC instruction register. Sequential writes to the same register are achieved by setting the Inhibit Auto Incrementing (IAI) bit 7 in RADD, the register address byte.
2. Load the number of bytes (less one) in the DiSEqC instruction in the register DiS_Mode[5:3].

3. Set DiS_Mode[2:0] = 4 to command the ZL10313 to encode the data and transmit the message.
4. Reset DiS_Mode[2:0] to either 0 or 1 depending on previous setting of 22 kHz off or on. The data loaded into the DiSEqC_INSTR register is retained, so that if the same message is to be repeated, stage 1 above can be omitted.

2.6.2 DiSEqC Receiving Messages

The ZL10313 will automatically listen for DiSEqC messages 5 ms after a message has been transmitted. If a return message is expected, the DiS_Mode[2:0] must be set to zero in order to leave the LNB control signal free for another DiSEqC transmitter to respond. The sequence of events to receive a message are as follows:

1. Ensure that DiSEqC2/GPP2 pin 2 is an input by setting GPP_CTRL register address-20 bit-5 to zero.
2. Enable interrupts if the $\overline{\text{IRQ}}$ pin 43 is used to interrupt the host processor in DiSEqC2_CTRL1 register 121.
3. Monitor DiS_INT register.
4. If bit-3 = 1 and bit-1 = 0, there has been no message received.
5. If a message has been received, bit-0 will be set. If bit-1 is also set the message is complete. DiS_INT register bits-7-4 indicate how many bytes have been received.
6. Read the received message from DiS_FIFO register 120 by setting the Inhibit Auto Incrementing (IAI) bit-7 in RADD, the register address byte and sequentially reading DiS_FIFO for the indicated number of bytes. Each data byte read requires two 2-wire bus reads. The second or the pair of bytes contains the parity bit and a parity bit error indicator.

The user may choose to wait for the end of message indication, before reading the message, if it is known that the message is not greater than eight bytes. However, if the length of message is not known, the message should be read out of the FIFO by the host as it is being received. Care must be taken to avoid a FIFO buffer overflow. DiS_INT register bits-7-4 will indicate how many bytes remain in the FIFO.

3.0 Microprocessor Control

3.1 RADD: 2-wire Register Address (W)

RADD is the internal 2-wire bus register address. It is the first byte written after the ZL10313 2-wire bus address when in write mode.

To write to the chip, the bus master should send a START condition and the chip address with the write bit set, followed by the register address where subsequent data bytes are to be written. Finally, when the 'message' has been sent, a STOP condition is sent to free the bus.

To read from the chip from register address zero, the bus master should send a START condition and the chip address with the read bit set, followed by the requisite number of clocks to read the bytes out. Finally a STOP condition is sent to free the bus. RADD is not sent in this case.

To read from the chip from an address other than zero, the bus master should send the chip address with the write bit set, followed by the register address from where subsequent data bytes are to be read. Then the bus master should send a repeat START condition and the chip address with the read bit set, followed by the requisite number of CLK1 clocks to read the required bytes out. Finally a STOP condition is sent to free the bus. A STOP condition resets the RADD value to 00.

RADD (virtual register, address none)

NAME	ADR	bit-7	bit-6	bit-5	bit-4	bit-3	bit-2	bit-1	bit-0		Def hex
RADD	N/A	IAI	AD6	AD5	AD4	AD3	AD2	AD1	AD0	W	-

bit-7: IAI High = Inhibit auto increment
Low = Increment addresses

bits 6-0: AD[6:0] register address, numbers in the range 0 to 127 are allowed

When the register address is incremented to 127 it stops and the bus will continue to write to or read from register 127 until a STOP condition is sent.

3.2 Primary 2-wire Bus Interface

The primary 2-wire bus serial interface uses pins:

DATA1 (pin 11) serial data, the most significant bit is sent first.

CLK1 (pin 10) serial clock.

The 2-wire bus address is determined by applying Vdd or Gnd to the ADDR[4:1] pins while the three MSBs of the address are internally set to '0'.

For compatibility with earlier devices, the 2-wire bus address will normally be 0001 110 $\overline{R/W}$ and the pins connected as follows:

Addr[4]	Addr[3]	Addr[2]	Addr[1]
Vdd	Vdd	Vdd	Gnd

When the ZL10313 is powered up, the $\overline{\text{Reset}}$ pin 1 should be maintained low for typically 100 ms after Vdd and CVdd have reached normal operation levels, and the Sleep pin 9 has gone low. This is to ensure that the crystal oscillator and internal PLL have become fully established and that the internal reset signal is fully clocked into all parts of the circuit. As the reset pin is pulled high, the logic levels on Addr[4:1] are latched to become the 2-wire bus address AD[6:0].

The circuit works as a slave transmitter with the eighth bit set high or as a slave receiver with the eighth bit set low. In receive mode, the first data byte is written to the RADD virtual register, which forms the register sub-address.

Bit 7 of the RADD register, IAI is an Inhibit Auto Increment function. When the IAI bit is set high, the automatic incrementing of register addresses is inhibited. IAI set low is the normal situation so that data bytes sent on the 2-wire bus after the RADD register data are loaded into successive registers. This automatic incrementing feature avoids the need to individually address each register.

Following a valid chip address, the 2-wire bus STOP command resets the RADD register to 00. If the chip address is not recognised, the ZL10313 will ignore all activity until a valid chip address is received. The 2-wire bus START command does NOT reset the RADD register to 00. This allows a combined 2-wire bus message to point to a particular read register with a write command, followed immediately with a read data command. If required, this could next be followed with a write command to continue from the latest address. Finally a STOP command should be sent to free the bus.

When the 2-wire bus is addressed (after a recognised STOP command) with the read bit set, the first byte read out will be the content of register 00.

3.3 Secondary 2-wire Bus for Tuner Control

The ZL10313 has a General Purpose Port that can be configured to provide a secondary 2-wire bus with full bi-directional operation. When pass-through is enabled, a transparent connection is made to the tuner. This innovative design simplifies the software required to program the tuner.

Pass-through mode is selected by setting register (20) GPP_CTRL[bit-6] = 1.

The allocation of the pins is: DATA2 = pin14, CLK2 = pin 15.

4.0 Electrical Characteristics

4.1 Recommended Operating Conditions

Parameter	Symbol	Min.	Typ.	Max.	Units
Core power supply voltage	CVdd	1.71	1.8	1.89	V
Periphery power supply voltage	Vdd	3.13	3.3	3.47	V
Input clock frequency (note ¹ & ²)	Fxt1	3.99		22.66	MHz
Crystal oscillator frequency	Fxt2	9.99		16.01	MHz
CLK1 clock frequency ³ (with 10 MHz or above)	Fclk1			400	kHz
Ambient operating temperature		0		70	°C

1. When not using a crystal, XTI may be driven from an external source over the frequency range shown.

2. The upper limit is set by DiSEqC requirements. If DiSEqC is not required, then external frequencies up to 27.00 MHz can be used.

3. The maximum serial clock speed on the primary 2-wire bus is related to the input clock frequency and is limited to 100 kHz with a 4.0 MHz clock.

4.2 Absolute Maximum Ratings

Parameter	Symbol	Min.	Max.	Unit
Power supply	Vdd	-0.3	4.5	V
	CVdd	-0.3	2.3	
Voltage on input pins (5 V rated)	Vi	-0.3	6.5	V
Voltage on input pins (3.3 V rated)	Vi	-0.3	Vdd + 0.5	V
Voltage on input pins (1.8 V rated, e.g., $\overline{\text{XTI}}$)	Vi	-0.3	CVdd + 0.5	V
Voltage on output pins (5 V rated)	Vo	-0.3	5.5	V
Voltage on output pins (3.3 V rated)	Vo	-0.3	Vdd + 0.5	V
Voltage on output pins (1.8 V rated, e.g., XTO)	Vo	-0.3	CVdd + 0.5	V
Storage temperature	Tstg	-55	150	°C
Operating ambient temperature	Top	0	70	°C
Junction temperature	Tj		125	°C
ESD protection (human body model)		2		kV

Note 1: Stresses exceeding these listed under 'Absolute Ratings' may induce failure. Exposure to absolute maximum ratings for extended periods may reduce reliability. Functionality at or above these conditions is not implied.

4.3 Primary 2-Wire Bus Timing

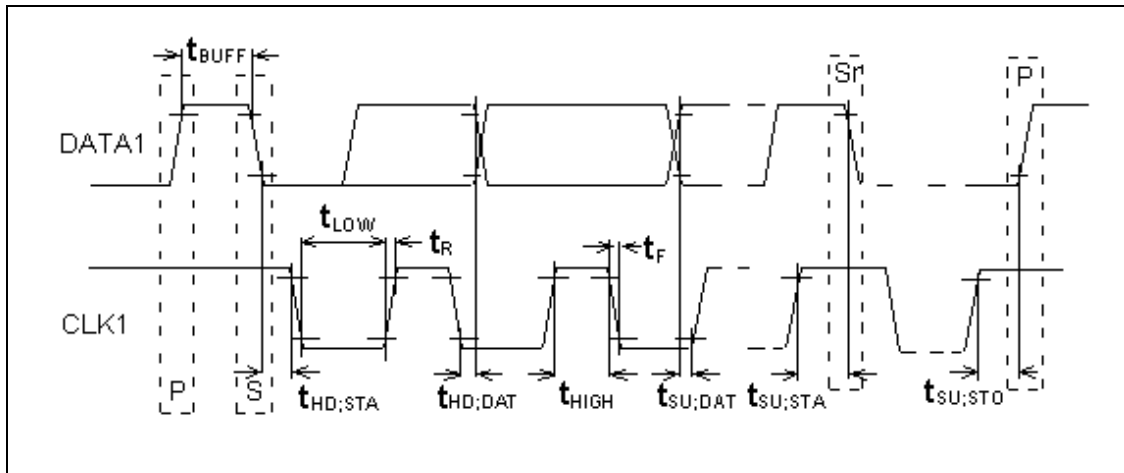

Figure 14 - Primary 2-Wire Bus Timing

Where: S = Start
 Sr = Restart, i.e., Start without stopping first.
 P = Stop

Parameter: Primary 2-wire bus only	Symbol	Value		Unit
		Min.	Max.	
CLK1 clock frequency (for $\overline{XTI} \geq 10\text{MHz}$)	f _{CLK}	0	400	kHz
Bus free time between a STOP and START condition	t _{BUF}	1300		ns
Hold time (repeated) START condition	t _{HD;STA}	600		ns
LOW period of CLK1 clock	t _{LOW}	1300		ns
HIGH period of CLK1 clock	t _{HIGH}	600		ns
Set-up time for a repeated START condition	t _{SU;STA}	600		ns
Data hold time (when input)	t _{HD;DAT}	0		ns
Data set-up time	t _{SU;DAT}	100		ns
Rise time of both CLK1 and DATA1 signals	t _R	20+0.1Cb ¹	300 ²	ns
Fall time of both CLK1 and DATA1 signals, (100pF to ground)	t _F	20+0.1Cb ¹	300	ns
Set-up time for a STOP condition	t _{SU;STO}	600		ns

Table 1 - Primary 2-wire bus timing

1. C_b = the total capacitance on either clock or data line in pF.
2. The rise time depends on the external bus pull up resistor and bus capacitance.

4.4 Crystal Specification

Parallel resonant fundamental frequency (preferred) 9.99 to 16.01 MHz.

Tolerance over operating temperature range ± 25 ppm.

Tolerance overall ± 50 ppm.

Nominal load capacitance 30 pF.

Equivalent series resistance $< 75 \Omega$

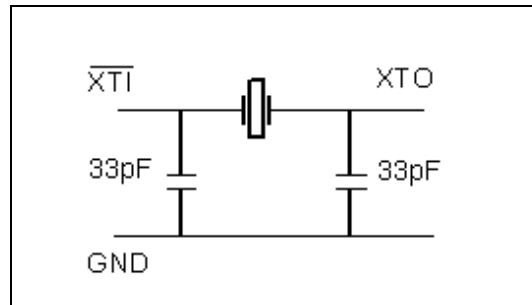

Figure 15 - Crystal Oscillator Circuit

Note: The crystal frequency should be chosen to ensure that the system clock would marginally exceed the maximum symbol rate required, e.g. 10.111 MHz with a multiplier of x9 will give a 91 MHz system clock to guarantee 45 MSps operation.

4.5 Electrical Characteristics

Conditions (unless specified otherwise): $T_{amb} = 25^{\circ}\text{C}$

$CV_{dd} = 1.8 \text{ V}$ $V_{dd} = 3.3 \text{ V}$

DC Electrical Characteristics

Parameter	Conditions/Pin	Symbol	Min.	Typ.	Max.	Unit
Core voltage		CV _{dd}	1.71	1.8	1.89	V
Peripheral voltage		V _{dd}	3.13	3.3	3.47	V
Core current	45 MSps CR 7/8 91 MHz system clock	CI _{dd}		165		mA
Peripheral current		I _{dd}		7		mA
Total power (91 MHz system clock)		P _{tot1}		320		mW
Total power (stand-by)	ADCs powered down. MPEG outputs tri-stated	P _{tot2} ¹		2.2		mW
Total power (sleep)	Pin 9 = logic '1' ADCs powered down	P _{tot3} ¹		0.35		mW
Output low level	2, 6 or 12 mA per output (see section 4.6, ZL10313 Pinout Description)	V _{ol}			0.4	V
Output high level	2, 6 or 12 mA per output	V _{oh}	2.4			V
Output leakage	Tri-state when off or open-drain when high				± 1	μA

DC Electrical Characteristics (continued)

Parameter	Conditions/Pin	Symbol	Min.	Typ.	Max.	Unit
Output capacitance	All outputs except XTO, CLK1 & open-drain types. Excludes packaging contribution (~0.35 pF)			2.7		pF
	Open-drain outputs. Excludes packaging contribution (~0.35 pF)			3.3		pF
Input low level		V _{il}			0.8	V
Input high level		V _{ih}	2.0			V
Input leakage	V _{in} = 0 or V _{dd}				±1	µA
Input capacitance	Excludes packaging contribution (~0.35 pF)			1.5		pF

1. For minimum power, MPEG outputs should be tristated and ADCs powered down.

AC Electrical Characteristics

Parameter	Conditions/Pin	Min.	Typ.	Max.	Unit
ADC Full-scale input single range (single-ended or differential)	Differential source is recommended		0.5	1.0	V _{pp}
ADC analog input resistance	Per input pin	10			kΩ
ADC analog input capacitance	Per input pin		2		pF
ADC input common mode voltage level		0.7		1.7	V
System clock frequency		30.00		100	MHz
Input clock frequency (note ¹ and ²)		3.99		22.66	MHz
Crystal oscillator frequency	See Section 4.4 for details	9.99		16.01	MHz
CLK1 clock frequency ³ (with 10 MHz xtal or above)				400	kHz
MPEG clock input frequency	On either pin #2 or pin #43	note ⁴		65 ⁵	MHz

1. When not using a crystal, $\overline{\text{XTI}}$ may be driven from an external source over the frequency range shown.

2. The upper limit is set by DiSEqC requirements. If DiSEqC is not required, then external frequencies up to 27.00 MHz can be used.

3. The maximum serial clock speed on the primary 2-wire bus is related to the input clock frequency and is limited to 100 kHz with a 4.0 MHz clock.

4. Must be calculated from the data input rate.

5. Also subject to system clock limitations.

4.6 ZL10313 Pinout Description

Pin Description Table

Pin	Name	Description	I/O	Note	V	mA
1	Reset	Active low reset input	I	CMOS ¹	5	
2	DiSEqC[2]	DiSEqC input for level 2 control. Also usable as GPP2 (general purpose port pin) for other purposes, and as MICLK - external clock input for MPEG data.	I/O	Open drain ¹	5	6
3	DiSEqC[1]	Horizontal/vertical LNB control (acts as input only in production test modes)	I/O	CMOS	3.3	2
4	DiSEqC[0]	22 kHz output to LNB (acts as input only in production test modes)	I/O	CMOS	3.3	2
9	Sleep	Stops oscillator and sets minimum power levels to entire device (except ADCs - register controlled power-down)	I	CMOS	3.3	
10	CLK1	Primary 2-wire serial bus clock	I	CMOS ¹	5	
11	DATA1	Primary 2-wire serial bus data	I/O	Open drain ¹	5	6
14	DATA2	Secondary 2-wire bus data to tuner front end. Also usable as GPP1 (general purpose port pin) for other purposes.	I/O	Open drain ¹	5	6
15	CLK2	Secondary 2-wire bus clock to tuner front end. Also usable as GPP0 (general purpose port pin) for other purposes.	I/O	Open drain ¹	5	6
16	OscMode	Controls oscillator mode to suit crystal or external signal	I	CMOS	3.3	
19	XTI	Crystal input or external reference clock input	I	CMOS	1.8	
20	XTO	Crystal output, includes internal feedback resistor to XTI	I/O	CMOS	1.8	
24	Iin	I channel input	I	analog		
25	Iin	I channel negative input	I	analog		
29	Qin	Q channel negative input	I	analog		
30	Qin	Q channel input	I	analog		
35,36,37 38	ADDR[1:4]	Primary 2-wire bus address defining pins	I	CMOS	3.3	
41	AGC	AGC sigma-delta output (acts as input only in production test modes)	I/O	Open drain ¹	5	6
42	Test	For normal operation, this pin must be held at 0 V.	I	CMOS	3.3	
43	IRQ	Active low interrupt output. Reading all active interrupt registers resets this pin. Can also be defined as MICLK - external clock input for MPEG data	I/O	Open drain ¹	5	6
46	MOSTRT	MPEG output start signal. High during the first byte of a packet.	O	CMOS Tri-state	3.3	2

Pin Description Table

Pin	Name	Description	I/O	Note	V	mA
47	MOVAL	MPEG data output valid. High during the MOCLK cycles when valid data bytes are being output.	O	CMOS Tri-state	3.3	2
48,49,52, 53,56, 57,60,61	MDO[0:7]	MPEG transport packet data output bus. Can be tri-stated under control of a register bit.	O	CMOS Tri-state	3.3	2
62	MOCLK	MPEG clock output at the data byte rate.	O	CMOS Tri-state	3.3	12
63	BKERR	Active low uncorrectable block indicator or no-signal indicator. Mode selected by ERR_IND bit (#7) of the MON_CTRL register. Can also be inverted.	O	CMOS Tri-state	3.3	2
64	STATUS	Status output. Register defined function including audio frequency proportional to BER (acts as input only in production test modes)	I/O	CMOS	3.3	2
5, 39, 55	Vdd	Peripheral supply pins. All pins must be connected.			3.3	
27	Vdd	Peripheral supply pin used for the ADC.			3.3	
7, 12, 44, 50, 59	CVdd	Core supply pins. All pins must be connected.			1.8	
17, 22, 32, 34	CVdd	PLL/ADC supply pins. All pins must be connected.			1.8	
6, 8, 13, 40, 45 51, 54, 58	Gnd	Ground supply pins. All pins must be connected.			0	
18, 21, 23 26, 28, 31, 33	Gnd	PLL/ADC ground supply pins. All pins must be connected.			0	

Note 1: 5 V tolerant pins with thresholds related to 3.3 V.

4.7 Alphabetical Listing of Pin-Out

Name	No.	Name	No.	Name	No.	Name	No.
Addr[1]	35	CVdd	59	Gnd	40	MOCLK	62
Addr[2]	36	DATA1	11	Gnd	45	MOSTRT	46
Addr[3]	37	DATA2	14	Gnd	51	MOVAL	47
Addr[4]	38	DiSEqC[0]	4	Gnd	54	OscMode	16
AGC	41	DiSEqC[1]	3	Gnd	58	\overline{Qin}	29
\overline{BKERR}	63	DiSEqC[2]	2	lin	24	Qin	30
CLK1	10	Gnd	6	\overline{lin}	25	\overline{Reset}	1
CLK2	15	Gnd	8	\overline{IRQ}	43	Sleep	9
CVdd	7	Gnd	13	MDO[0]	48	Status	64
CVdd	12	Gnd	18	MDO[1]	49	Test	42
CVdd	17	Gnd	21	MDO[2]	52	Vdd	5
CVdd	22	Gnd	23	MDO[3]	53	Vdd	27
CVdd	32	Gnd	26	MDO[4]	56	Vdd	39
CVdd	34	Gnd	28	MDO[5]	57	Vdd	55
CVdd	44	Gnd	31	MDO[6]	60	\overline{XTI}	19
CVdd	50	Gnd	33	MDO[7]	61	XTO	20

5.0 References

1. European Digital Video Broadcast Standard, ETS 300 421 (A1) Version 1.1.2 - 1997-08.
ETS Secretariat
06921 Sophia Antipolis Cedex
France.
2. Digital Satellite Equipment Control (DiSEqC)
DiSEqC™ Bus Specification Version 4.2 (February 25, 1998)
EUTELSAT
European Telecommunications Satellite Organisation
70, rue Balard - 75502 PARIS Cedex 15
France.

6.0 Trademarks

DiSEqC™ is a trademark of EUTELSAT.

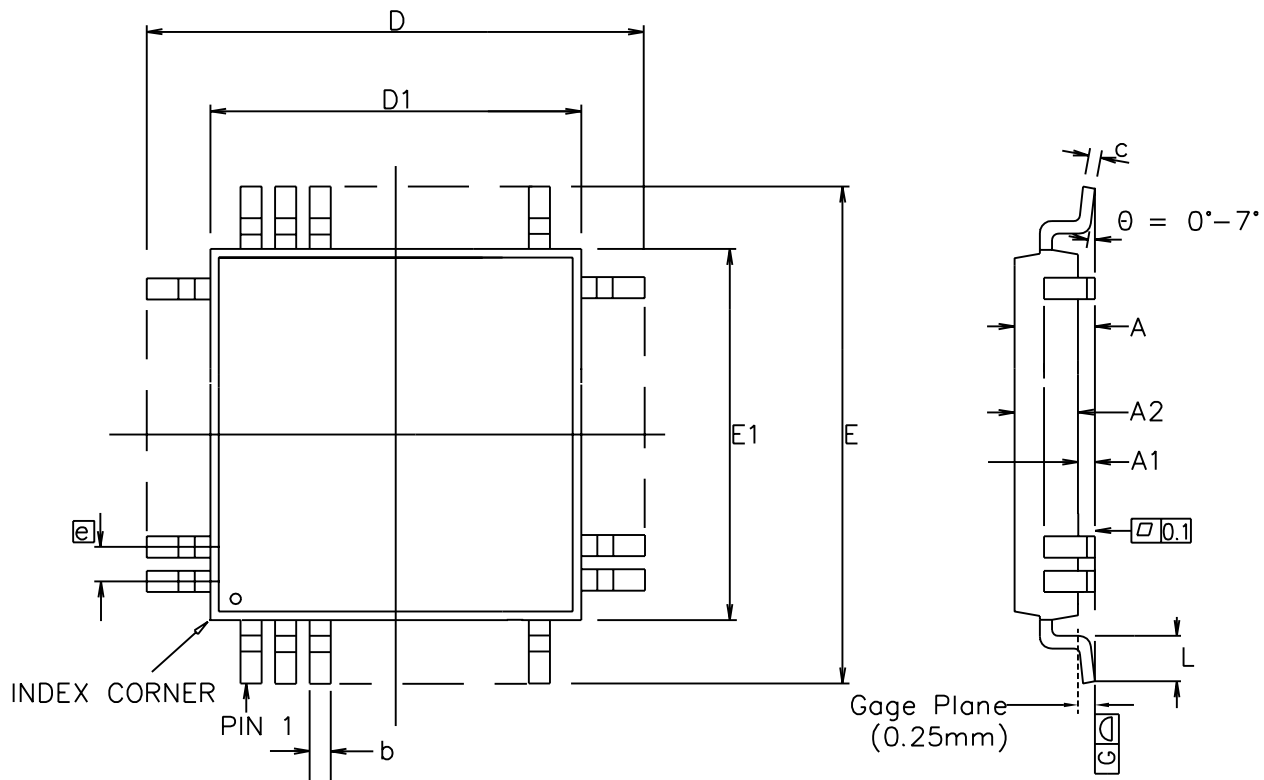

Symbol	Control Dimensions in millimetres		Altern. Dimensions in inches	
	MIN	MAX	MIN	MAX
A	---	1.60	---	0.063
A1	0.05	0.15	0.002	0.006
A2	1.35	1.45	0.053	0.057
D	9.00	BSC	0.354	BSC
D1	7.00	BSC	0.276	BSC
E	9.00	BSC	0.354	BSC
E1	7.00	BSC	0.276	BSC
L	0.45	0.75	0.018	0.030
e	0.40	BSC	0.016	BSC
b	0.13	0.23	0.005	0.009
c	0.09	0.20	0.004	0.008
Pin features				
N	64			
ND	16			
NE	16			
NOTE	SQUARE			

Conforms to JEDEC MS-026 BBD Iss. C

Notes:

1. Pin 1 indicator may be a corner chamfer, dot or both.
2. Controlling dimensions are in millimeters.
3. The top package body size may be smaller than the bottom package body size by a max. of 0.15 mm.
4. Dimension D1 and E1 do not include mould protrusion.
5. Dimension b does not include dambar protrusion.
6. Coplanarity, measured at seating plane G, to be 0.08 mm max.

This drawing supersedes 418/ED/51210/031 (Swindon)

© Zarlink Semiconductor 2002 All rights reserved.					Package Code	QC
ISSUE	1	2	3		Previous package codes	Package Outline for 64 lead LQFP (7 x 7 x 1.4mm) 2mm Footprint
ACN	201370	207115	212445		GP / B	
DATE	29Oct96	9Jul99	26Mar02			
APPRD.					GPD00250	



**For more information about all Zarlink products
visit our Web Site at
www.zarlink.com**

Information relating to products and services furnished herein by Zarlink Semiconductor Inc. or its subsidiaries (collectively "Zarlink") is believed to be reliable. However, Zarlink assumes no liability for errors that may appear in this publication, or for liability otherwise arising from the application or use of any such information, product or service or for any infringement of patents or other intellectual property rights owned by third parties which may result from such application or use. Neither the supply of such information or purchase of product or service conveys any license, either express or implied, under patents or other intellectual property rights owned by Zarlink or licensed from third parties by Zarlink, whatsoever. Purchasers of products are also hereby notified that the use of product in certain ways or in combination with Zarlink, or non-Zarlink furnished goods or services may infringe patents or other intellectual property rights owned by Zarlink.

This publication is issued to provide information only and (unless agreed by Zarlink in writing) may not be used, applied or reproduced for any purpose nor form part of any order or contract nor to be regarded as a representation relating to the products or services concerned. The products, their specifications, services and other information appearing in this publication are subject to change by Zarlink without notice. No warranty or guarantee express or implied is made regarding the capability, performance or suitability of any product or service. Information concerning possible methods of use is provided as a guide only and does not constitute any guarantee that such methods of use will be satisfactory in a specific piece of equipment. It is the user's responsibility to fully determine the performance and suitability of any equipment using such information and to ensure that any publication or data used is up to date and has not been superseded. Manufacturing does not necessarily include testing of all functions or parameters. These products are not suitable for use in any medical products whose failure to perform may result in significant injury or death to the user. All products and materials are sold and services provided subject to Zarlink's conditions of sale which are available on request.

Purchase of Zarlink's I²C components conveys a licence under the Philips I²C Patent rights to use these components in and I²C System, provided that the system conforms to the I²C Standard Specification as defined by Philips.

Zarlink, ZL and the Zarlink Semiconductor logo are trademarks of Zarlink Semiconductor Inc.

Copyright Zarlink Semiconductor Inc. All Rights Reserved.

TECHNICAL DOCUMENTATION - NOT FOR RESALE
