

## Features

- 402-405 MHz (10 MICS channels) and 433-434 MHz (2 ISM channels)
- High data rate (800/400/200 kbps raw data rate)
- High performance MAC with automatic error handling and flow control, typ <math>1.5 \times 10^{-10}</math> BER.
- Very few external components (2 pcs + antenna matching)
- Extremely low power consumption (5 mA, continuous TX/RX, <math><1</math> mA low power mode)
- Ultra low power wakeup circuit (200 nA)
- Standards compatible (MICS, FCC, IEC)

## Applications

- Implantable Devices e.g., Pacemakers, ICD's, Cochlea implants, Neurostimulators, Implantable Insulin Pumps, Bladder Control Devices, implantable physiological monitors
- Body area network, short range device applications using the 433 MHz ISM band.

### Ordering Information

ZL70100LDF1 - 48 pin QFN\* (tape & reel, bake and drypack)

ZL70100LDG1 -48 pin QFN\* (tray, bake and drypack)

\*Pb Free Matte Tin

**0°C to +55°C**

## Description

The ZL70100 is a high performance half duplex RF communications link for medical implantable applications. The system is very flexible and supports several low power wakeup options. Extremely low power is achievable using the 2.45 GHz ISM Band Wakeup-receiver option. The high level of integration includes a Media Access Controller, providing complete control of the device along with coding and decoding of RF messages. A standard SPI interface provides for easy access by the application

For further information please contact sales.

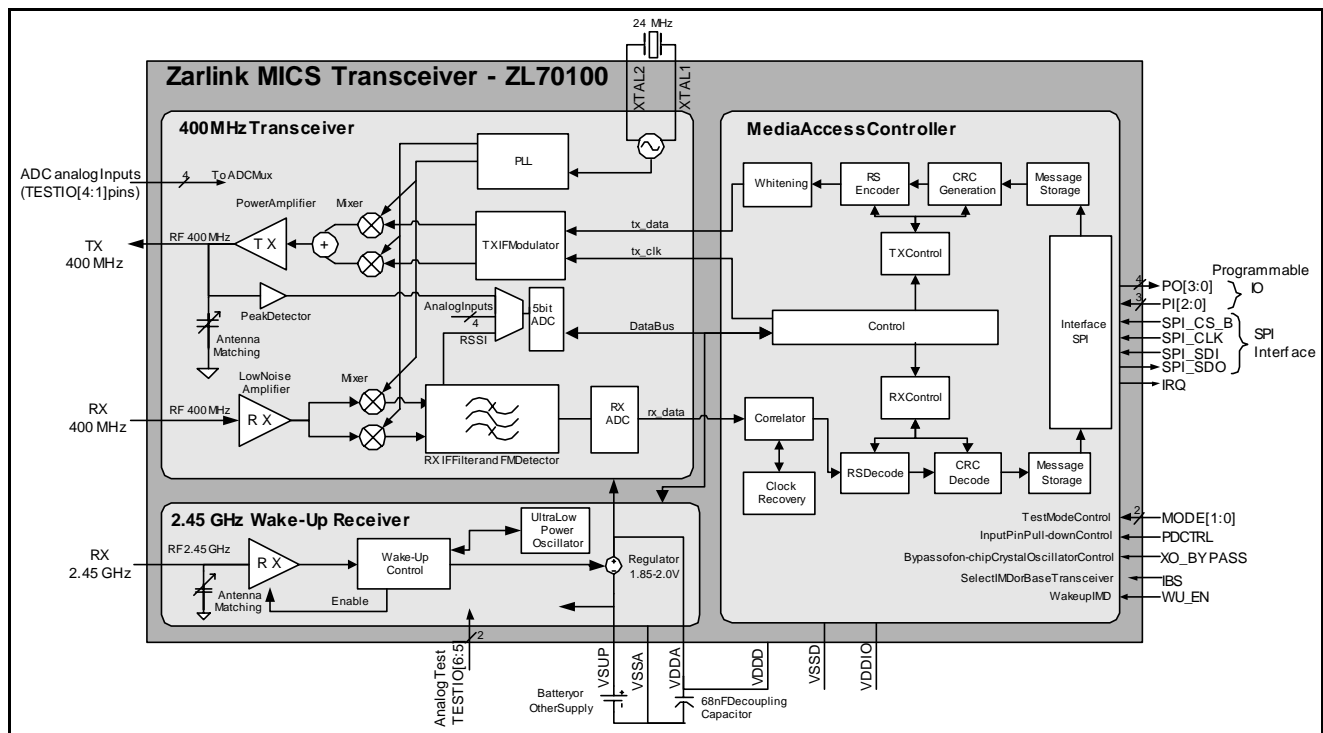

**Figure 1 - ZL70100 Block Diagram**

## 1.0 Functional Description

### 1.1 General

The ZL70100 is an ultra low power, high bandwidth RF link for medical implantable applications. It operates in the MICS (Medical Implantable Service Band) at 402-405 MHz. It uses a Reed-Solomon coding scheme together with CRC error detection to achieve an extremely reliable link. For data-blocks, a maximum BER (Bit Error Rate) of less than  $1.5 \times 10^{-10}$  is provided assuming a raw radio channel quality of  $10^{-3}$  BER. An even higher quality of  $2 \times 10^{-14}$  BER is available using Housekeeping messages, a facility fully described in the ZL70100 Design Manual.

### 1.2 Basic Operation and Modes

The MICS transceiver is intended for operation in both an Implant and Basestation. These systems have different requirements especially with regard to power consumption. Therefore, the MICS transceiver has defined two fundamental startup modes of operation:

- Implantable Medical Device (IMD) Mode
- Basestation Mode

When configured as an IMD, the transceiver is usually asleep and in a very low current state. The IMD transceiver may be woken up by either receipt of a specially coded 2.45 GHz wakeup message or directly by the IMD processor via the WU\_EN pin. This flexibility leads to the following options for waking up an IMD transceiver for communication.

- IMD transceiver woken up by specially coded 2.45 GHz wakeup message using an ultra low power sniffing method.
- IMD transceiver woken up to sniff 400 MHz link. The ZL70100 supports such a mode of operation although the 2.45 GHz wakeup system has lower power consumption.
- IMD transceiver woken to send an emergency message in which case no clear channel assessment by the Basestation is required.
- IMD transceiver woken up by a low frequency inductive link (as typically used in pacemakers/ICDs) or some alternative mechanism.

## 2.0 Example Configurations

The MICS Transceiver device is configurable as an Implant transceiver or as a Basestation transceiver. Typical configurations are shown in the following diagrams.

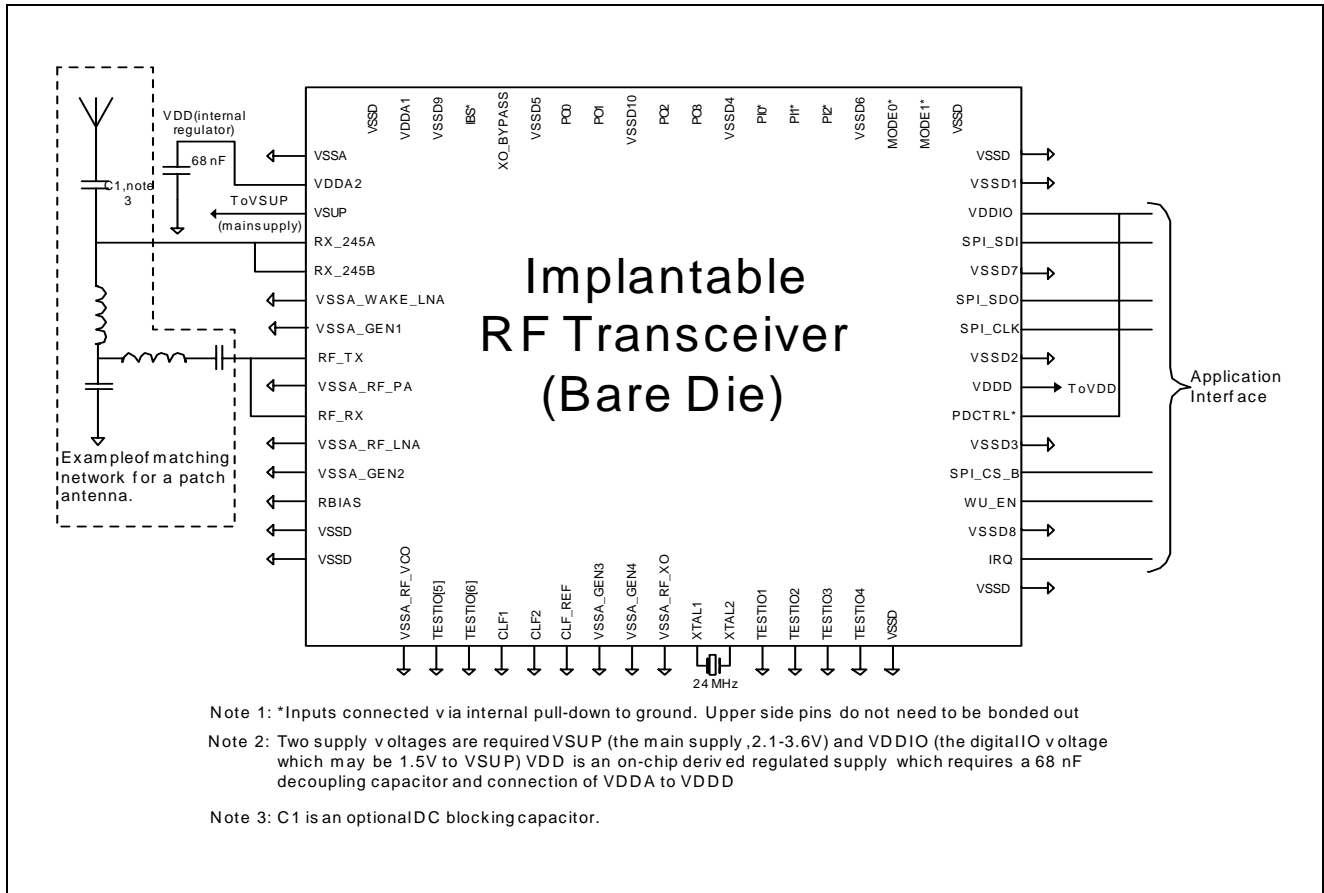

**Figure 2 - MICS Transceiver Configured for an Implant**



### 3.0 Electrical Characteristics

**Absolute Maximum ratings** - Voltages are with respect to ground (VSS) unless otherwise stated.

	Parameter	Symbol	Min.	Max.	Unit	Notes
1	Supply voltage	VSUP	0	3.6	V	
2	Input voltage (Digital IO)	VDDIO	0	3.6	V <sub>peak</sub> rel. to VSS	
3	Storage temperature	T <sub>stg</sub>	-40	+70	°C	

**Recommended Operating Conditions** - Note1

	Parameter	Symbol	Min.	Typ.	Max.	Unit	Notes
4	Supply voltage	VSUP	2.1		3.5	V	
5	Input voltage (Digital IO)	VDDIO	1.5		VSUP	V	Note 2
6	Operating temperature	T <sub>op</sub>	0		55	°C	

Note 1: The table above lists the external conditions under which the chip shall operate according to the specifications detailed within this document.

Note 2: Note that VDDIO must always be less than VSUP even during system startup.



**For more information about all Zarlink products  
visit our Web Site at  
[www.zarlink.com](http://www.zarlink.com)**

Information relating to products and services furnished herein by Zarlink Semiconductor Inc. or its subsidiaries (collectively "Zarlink") is believed to be reliable. However, Zarlink assumes no liability for errors that may appear in this publication, or for liability otherwise arising from the application or use of any such information, product or service or for any infringement of patents or other intellectual property rights owned by third parties which may result from such application or use. Neither the supply of such information or purchase of product or service conveys any license, either express or implied, under patents or other intellectual property rights owned by Zarlink or licensed from third parties by Zarlink, whatsoever. Purchasers of products are also hereby notified that the use of product in certain ways or in combination with Zarlink, or non-Zarlink furnished goods or services may infringe patents or other intellectual property rights owned by Zarlink.

This publication is issued to provide information only and (unless agreed by Zarlink in writing) may not be used, applied or reproduced for any purpose nor form part of any order or contract nor to be regarded as a representation relating to the products or services concerned. The products, their specifications, services and other information appearing in this publication are subject to change by Zarlink without notice. No warranty or guarantee express or implied is made regarding the capability, performance or suitability of any product or service. Information concerning possible methods of use is provided as a guide only and does not constitute any guarantee that such methods of use will be satisfactory in a specific piece of equipment. It is the user's responsibility to fully determine the performance and suitability of any equipment using such information and to ensure that any publication or data used is up to date and has not been superseded. Manufacturing does not necessarily include testing of all functions or parameters. These products are not suitable for use in any medical products whose failure to perform may result in significant injury or death to the user. All products and materials are sold and services provided subject to Zarlink's conditions of sale which are available on request.

Purchase of Zarlink's I<sup>2</sup>C components conveys a licence under the Philips I<sup>2</sup>C Patent rights to use these components in and I<sup>2</sup>C System, provided that the system conforms to the I<sup>2</sup>C Standard Specification as defined by Philips.

Zarlink, ZL and the Zarlink Semiconductor logo are trademarks of Zarlink Semiconductor Inc.

Copyright Zarlink Semiconductor Inc. All Rights Reserved.

**TECHNICAL DOCUMENTATION - NOT FOR RESALE**

---