

ZXFV4089

VIDEO AMPLIFIER WITH DC RESTORATION

DEVICE DESCRIPTION

The ZXFV4089 is a DC restoring circuit and low-distortion video amplifier. It is specially designed to provide brightness level stability as a 'black-level clamp' in video systems with very low distortion and low power consumption.

A high fidelity video amplifier is combined with a sample-and-hold switch circuit using an external coupling capacitor to provide level-shifting of the video output such that a time-gated sample of the waveform is set to be equal to an external reference voltage (usually zero voltage). A buffered TTL/CMOS logic input signal controls the switch.

The gain is set externally by two resistors.

In a typical application, the sample-and-hold circuit is gated on during part of the back-porch interval of an analog video waveform. Then the video waveform is stabilised for the remainder of the line-scan interval.

FEATURES AND BENEFITS

- Various TV systems, PAL, NTSC, SECAM
- Buffered output using high quality video amplifier
- Gain is set using two external resistors
- On chip sample/hold capacitor
- 300 MHz bandwidth
- 0.02% differential gain
- 0.02° differential phase
- +/-5V supply operation
- 8 mA supply current
- Pin and function compatible with industry standard part

APPLICATIONS

- Black Level Clamp, providing stable intensity in video systems such as
 - cameras
 - image capture
 - video mixing
 - displays
- DC restoration of other high frequency signals

ORDERING INFORMATION

Part Number	Container	Increment
ZXFV4089N8TA	Reel 7"	500
ZXFV4089N8TC	Reel 13"	2500

CONNECTION DIAGRAM

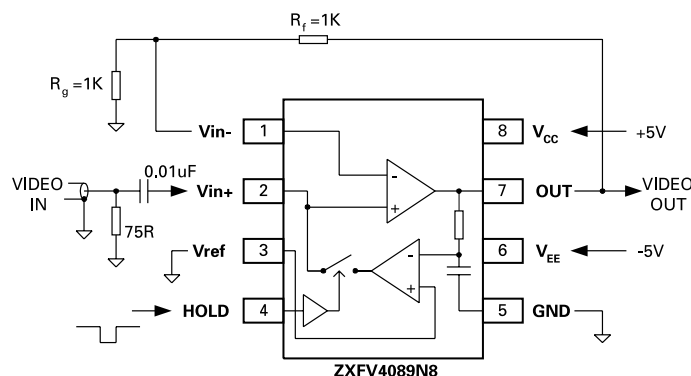

ZXFV4089

ABSOLUTE MAXIMUM RATINGS

Positive Supply voltage V_{CC} to GND	-0.5V to +5.5V
Negative Supply Voltage V_{EE} to GND	-5.5V to +0.5V
Input voltage, pins 1,2,3 to GND	$V_{EE} - 0.5V$ to $V_{CC} + 0.5V$
Output current, pin 7	60mA
Current into V_{in} and HOLD, pins 2 & 4	5mA
Operating Temperature Range	-40°C to 85°C Storage -65°C to +150°C
Operating Ambient Junction temperature T_{JMAX}	150°C**

**The thermal resistance from the semiconductor die to ambient is typically 120°C/W when the SO16 package is mounted on a PCB in free air. The power dissipation of the device when loaded must be designed to keep the device junction temperature below T_{JMAX} .

*During power-up and power-down, these voltage ratings require that signals be applied only when the power supply is connected.

ELECTRICAL CHARACTERISTICS

$V_{CC} = 5V$, $V_{EE} = -5V$, R_F and $R_G = 1k\Omega$, $R_{LOAD} = 1k$, $T_{amb} = 25^\circ C$ unless otherwise stated.

PARAMETER	CONDITIONS	P/C	MIN	TYP	MAX	UNIT
DC characteristics						
V_{CC} Supply current, holding	HOLD = HIGH	P		8	10	mA
V_{CC} Supply current, sampling	HOLD = LOW	P		8.5	11	mA
V_{EE} Supply current, holding	HOLD = HIGH	P		8	10	mA
V_{EE} Supply current, sampling	HOLD = LOW	P		8.5	11	mA
Amplifier section						
Input offset voltage	HOLD = HIGH	P		1	10	mV
+ input bias current	HOLD = HIGH	P		5	10	μA
- input bias current	HOLD = HIGH	P		5	10	μA
Transimpedance	HOLD = HIGH	P	500	1800		$K\Omega$
+ input resistance	HOLD = HIGH	P	1.5	2		$M\Omega$
Open loop gain	HOLD = HIGH	P	48	61		dB
Output voltage swing	HOLD = HIGH	P	± 2.5	± 3.0		V
Output drive current	HOLD = HIGH	P	40			mA
Positive Power Supply Rejection Ratio	HOLD = HIGH	P	49	57		dB
Negative Power Supply Rejection Ratio	HOLD = HIGH	P	51	58		dB
Common mode input voltage range	HOLD = HIGH	C		± 3		V
Amplifier output voltage swing	HOLD = HIGH	P	± 2.5	± 3.5		V
Restore section						
Composite Input Offset Voltage, from V_{REF} to amplifier output	HOLD = LOW	P		3	7	mV
V_{REF} input bias current	HOLD = LOW	P		3	12	μA
Input restore current available, pin 2	HOLD = LOW	P	180	300		μA

TEST - P = 100% production tested, C = characterised



ZXFV4089

ELECTRICAL CHARACTERISTICS

$V_{CC} = 5V$, $V_{EE} = -5V$, R_F and $R_G = 1k\Omega$, $R_{LOAD} = 1k$, $T_{amb} = 25^\circ C$ unless otherwise stated.

PARAMETER	CONDITIONS	P/C	MIN	TYP	MAX	UNIT
V_{REF} input voltage range	HOLD = LOW	C		± 2		V
Positive Power Supply Rejection Ratio	HOLD = LOW	P	60	90		dB
Negative Power Supply Rejection Ratio	HOLD = LOW	P	60	90		dB
Logic input HIGH V_{Hmin}		P			2	V
Logic input LOW V_{Lmax}		P	0.8			V
Logic input Low current, I_{IL}	HOLD = LOW	P		40	100	μA
Logic input High current, I_{IH}	HOLD = HIGH	P		12		μA
AC characteristics	$R_f = R_g = 1k$ ohms, $R_{LOAD} = 150$ ohms, $C_{LOAD} = 10$ pF					
Amplifier section						
Slew Rate	HOLD = HIGH, 2V pk-pk	C		400		V/ μs
Bandwidth, -3dB	HOLD = HIGH	C		300		MHz
Bandwidth, ± 0.1 dB	HOLD = HIGH	C		100		MHz
Differential Gain, NTSC	HOLD = HIGH, $f = 3.58$ MHz, 280mV pk-pk, DC = -714 to +714 mV	C		0.02		%
Differential Phase, NTSC	HOLD = HIGH, $f = 3.58$ MHz, 280mV pk-pk, DC = -714 to +714 mV	C		0.02		deg
Restore section						
Slew rate	HOLD = LOW	C		25		V/ μs
Time to enable Hold		C		25		ns
Time to disable Hold		C		40		ns

TEST - P = 100% production tested, C = characterised

1. The logic conditions for DC characteristics are: logic LOW = 0.8V max, logic HIGH = 2V min.

ZXFV4089

ZXFV4089 DETAILED OPERATING NOTES

Introduction

This device provides a video feed-back amplifier together with a sample-hold system to allow DC restoration. The Connection Diagram on page 1 shows a typical video signal application. No output termination is shown in the diagram, but if desired the output can drive a 75 ohm cable via a 75 ohm series terminating resistor.

Amplifier configuration

The amplifier configuration uses high gain with feedback in a non-inverting configuration. Two external resistors are required to set the gain. The restoration voltage is set by an external reference, V_{ref} , normally ground. The input signal is applied via an external input coupling capacitor which is used to store a DC control level when the sample-hold switch is open. When the switch is closed, the stored level is driven to a new value by an external sampling pulse.

DC restoration

HOLD is a TTL input signal which is buffered and controls the sample-hold switch. A logic LOW state closes the switch and so enables the feedback control loop to set the output level equal to V_{ref} (usually ground). The level of DC shift is maintained when the logic control returns to the HIGH state and the switch opens. In this way the whole waveform is conditionally level shifted, or 'restored' to the new DC level.

The sample-hold loop contains the video feed-back amplifier within its path, and also includes an additional sample-hold sense amplifier which compares V_{ref} with the output voltage using an internal low-pass filter. In the high state, the switch is open and the average DC level remains fixed apart from a small drift due to the input bias current of the amplifier and switch leakage (see below).

Video function

In the video application, the HOLD input state will be HIGH during the picture line sweep and a negative-going sampling pulse of typically 1.2 μ s duration will be applied during a central portion of the Back Porch interval, so that the Back Porch or 'Black' level is clamped to ground. For each line scan, this gives a brightness level consistent with that of the original camera signal, despite the AC coupling.

The value of the coupling capacitor affects two main characteristics of the circuit. Firstly, the available charging current, together with the capacitor value, determines the maximum DC voltage correction which can be applied at each sample. For a charging current limit of 300 μ A applied for 2 μ s, the charge injected is

$$Q_{max} = 300 \mu\text{A} \times 2 \mu\text{s} = 600 \text{ pC}$$

Then the maximum voltage shift correction is

$$V_{max} = Q_{max}/C = 600 \text{ pC} / 0.01 \mu\text{F} \\ = 60 \text{ mV}$$

Secondly, in the hold state, the voltage drift is affected as described below.

Sample-hold drift

In the HOLD state, the drift rate is equal to the bias/leakage current of about 1 μ A divided by the coupling capacitor value. For a value of 0.01 μ F, the drift rate is then 100 μ V/ μ s. For the typical video line scan, the switch remains open for the rest of the scan duration, or about 62 μ s. The drift at the end of the line scan has therefore accumulated to about 6.2 mV. This will be acceptable for most applications, but if desired it can be reduced by increasing the value of the coupling capacitor. This will result in a proportionately smaller value of the maximum available correction voltage at each scan as described above. Normally, once settled, the video system requires only a very small correction at each scan, so this will not present any problem.

Supply filtering & printed circuit layout

In the applied circuit, the power filtering and printed layout design needs special attention as is appropriate for a high-speed analog circuit. For each supply lead, use a leadless ceramic chip capacitor placed very close to the device power pin. A value of 0.1 μ F is recommended. In addition, a larger value capacitor, which should be ceramic or solid tantalum construction, with a value of 1 to 10 μ F, is also recommended for connection to each supply fairly close to the device.

The layout naturally requires some short interconnections on the component side (top copper layer) and a continuous ground plane should be provided on another layer with plated via holes providing low inductance ground connections for the device and other components. The amplifier frequency response is affected to some extent by stray capacitance at the inverting input at pin 1. This effect can be minimised by providing a small cut-out area in the ground plane and other layers around pin 1, though this may not always be necessary for the application.

ZXFV4089

PACKAGE OUTLINE

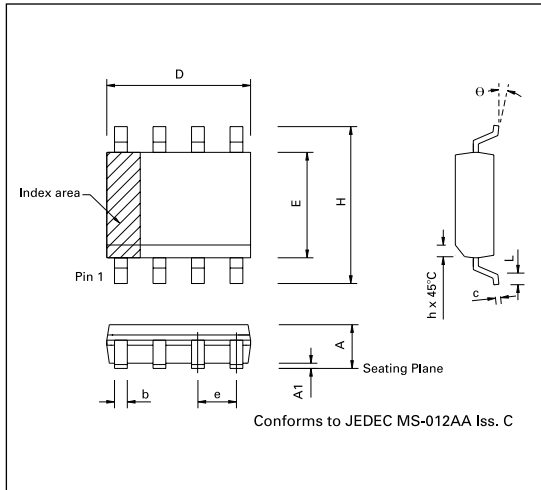

CONTROLLING DIMENSIONS ARE IN INCHES
APPROX IN MILLIMETRES

PACKAGE DIMENSIONS

DIM	INCHES		MILLIMETRES	
	MIN	MAX	MIN	MAX
A	0.053	0.069	1.35	1.75
A1	0.004	0.010	0.10	0.25
D	0.189	0.197	4.80	5.00
H	0.228	0.244	5.80	6.20
E	0.150	0.157	3.80	4.00
L	0.016	0.050	0.40	1.27
e	0.050 BSC		1.27 BSC	
b	0.013	0.020	0.33	0.51
c	0.008	0.010	0.19	0.25
θ	0°	8°	0°	8°
h	0.010	0.020	0.25	0.50

© Zetex plc 2002

Europe

Zetex plc
Fields New Road
Chadderton
Oldham, OL9 8NP
United Kingdom
Telephone (44) 161 622 4422
Fax: (44) 161 622 4420
uksales@zetex.com

Zetex GmbH
Streitfeldstraße 19
D-81673 München
Germany
Telefon: (49) 89 45 49 49 0
Fax: (49) 89 45 49 49 49
europe.sales@zetex.com

Americas

Zetex Inc
700 Veterans Memorial Hwy
Hauppauge, NY11788
USA
Telephone: (631) 360 2222
Fax: (631) 360 8222
usa.sales@zetex.com

Asia Pacific

Zetex (Asia) Ltd
3701-04 Metroplaza, Tower 1
Hing Fong Road
Kwai Fong
Hong Kong
Telephone: (852) 26100 611
Fax: (852) 24250 494
asia.sales@zetex.com

These offices are supported by agents and distributors in major countries world-wide.

This publication is issued to provide outline information only which (unless agreed by the Company in writing) may not be used, applied or reproduced for any purpose or form part of any order or contract or be regarded as a representation relating to the products or services concerned. The Company reserves the right to alter without notice the specification, design, price or conditions of supply of any product or service.

For the latest product information, log on to www.zetex.com

ADVANCED INFORMATION ISSUE D - SEPTEMBER 2002

