



0.75Ω、双路 SPDT 音频开关， 具有集成比较器

MAX4855

概述

MAX4855 双路单刀/双掷 (SPDT) 开关采用 +2V 至 +5.5V 电源供电，可处理满摆幅信号。MAX4855 采用 +3V 供电时具有较低的导通电阻 (0.75Ω)，非常适合于移动设备的音频开关应用。本器件还集成了两个内部比较器，可以用于耳机检测或静音/传送按键功能。

MAX4855 采用节省空间的 (3mm x 3mm)、16 引脚薄型 QFN 封装，工作在 -40°C 至 +85°C 扩展级温度范围。

应用

扬声器耳机切换
音频信号切换
蜂窝电话
笔记本电脑
PDA 及其它手持设备

特性

- ◆ 切换音频信号
- ◆ 0.75Ω 导通电阻
- ◆ 0.18Ω 导通电阻平坦度
- ◆ 0.07Ω 的通道间匹配度
- ◆ 可处理满摆幅信号
- ◆ 2 个集成比较器
- ◆ 兼容 1.8V 逻辑电平
- ◆ 2V 至 5.5V 电源范围
- ◆ 采用节省空间的 (3mm x 3mm) 16 引脚 TQFN 封装

订购信息

PART	TEMP RANGE	PIN-PACKAGE	TOP MARK
MAX4855ETE	-40°C to +85°C	16 TQFN-EP*	ABY

*EP = 裸露焊盘。

框图/真值表

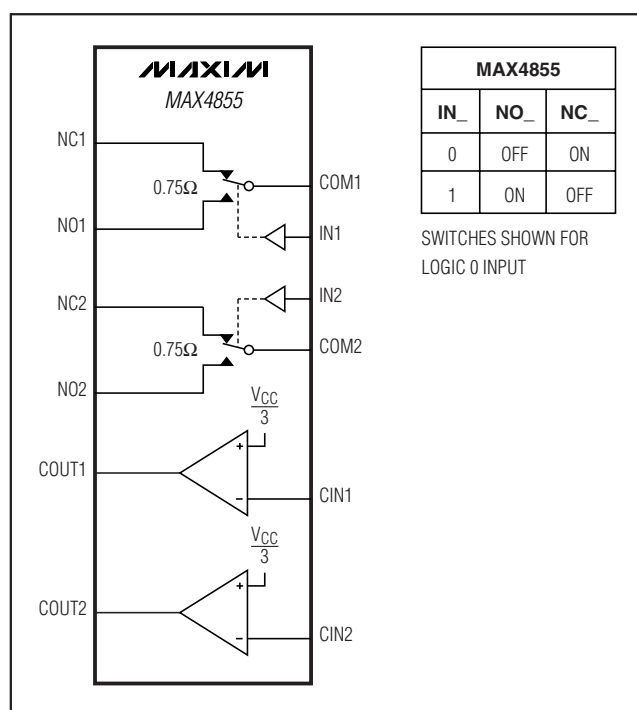

引脚配置

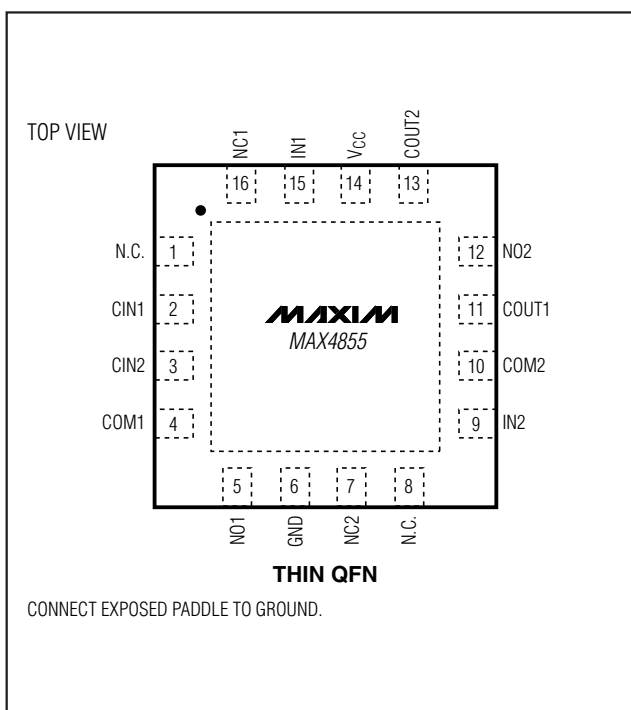

0.75Ω、双路 SPDT 音频开关， 具有集成比较器

ABSOLUTE MAXIMUM RATINGS

V _{CC} , IN ₋ , CIN ₋ to GND	-0.3V to +6.0V
NO ₋ , NC ₋ , COM ₋ , COUT ₋ (Note 1)	-0.3V to (V _{CC} + 0.3V)
COUT ₋ Continuous Current	±20mA
Closed Switch Continuous Current COM ₋ , NO ₋ , NC ₋	±300mA
Peak Current COM ₋ , NO ₋ , NC ₋ (pulsed at 1ms, 50% duty cycle)	±400mA
Peak Current COM ₋ , NO ₋ , NC ₋ (pulsed at 1ms, 10% duty cycle)	±500mA

Continuous Power Dissipation (T_A = +70°C)

16-Pin Thin QFN (derate 20.8mW/°C above +70°C)1667mW

Operating Temperature Range.....-40°C to +85°C

Junction Temperature.....+150°C

Storage Temperature Range

Lead Temperature (soldering, 10s).....+300°C

Note 1: Signals on NO, NC, or COM exceeding V_{CC} or GND are clamped by internal diodes. Signals on IN exceeding GND are clamped by an internal diode. Limit forward-diode current to maximum current rating.

Stresses beyond those listed under "Absolute Maximum Ratings" may cause permanent damage to the device. These are stress ratings only, and functional operation of the device at these or any other conditions beyond those indicated in the operational sections of the specifications is not implied. Exposure to absolute maximum rating conditions for extended periods may affect device reliability.

ELECTRICAL CHARACTERISTICS

(V_{CC} = +2.7V to +5.5V, T_A = -40°C to +85°C, unless otherwise noted. Typical values are at V_{CC} = +3.0V, T_A = +25°C, unless otherwise noted.) (Note 2)

PARAMETER	SYMBOL	CONDITIONS	MIN	TYP	MAX	UNITS
Supply Voltage	V _{CC}		2		5.5	V
Supply Current	I _{CC}	V _{CC} = 5.5V, V _{IN-} = 0V or V _{CC}		5	10	μA
ANALOG SWITCH						
Analog Signal Range	V _{NO-} , V _{NC-} , V _{COM-}		0		V _{CC}	V
On-Resistance (Note 3)	R _{ON}	V _{CC} = 2.7V, I _{COM-} = 100mA, V _{NC-} or V _{NO-} = 0V to V _{CC}	T _A = +25°C	0.75	1	Ω
			T _A = -40°C to +85°C			
On-Resistance Match Between Channels (Notes 3, 4)	ΔR _{ON}	V _{CC} = 2.7V, I _{COM-} = 100mA, V _{NC-} or V _{NO-} = 1.5V	T _A = +25°C	0.075	0.120	Ω
			T _A = -40°C to +85°C			
On-Resistance Flatness (Note 5)	R _{FLAT}	V _{CC} = 2.7V, I _{COM-} = 100mA, V _{NC-} or V _{NO-} = 0.75V, 1.5V, 1.75V	T _A = +25°C	0.18	0.275	Ω
			T _A = -40°C to +85°C			
NO ₋ /NC ₋ Off-Leakage Current (Note 2)	I _{OFF}	V _{CC} = 5.5V, V _{NC-} or V _{NO-} = 1V or 4.5V, V _{COM-} = 4.5V or 1V	T _A = +25°C	-2	+2	nA
			T _A = -40°C to +85°C	-10	+10	
COM ₋ On-Leakage Current (Note 2)	I _{ON}	V _{CC} = 5.5V; V _{NC-} or V _{NO-} = 1V, 4.5V, or floating; V _{COM-} = 1V, 4.5V, or floating	T _A = +25°C	-2	+2	nA
			T _A = -40°C to +85°C	-15	+15	
DYNAMIC CHARACTERISTICS						
Turn-On Time	t _{ON}	V _{CC} = 2.7V, V _{NO-} or V _{NC-} = 1.5V, R _L = 300Ω, C _L = 50pF (Figure 1)	T _A = +25°C	40	60	ns
			T _A = -40°C to +85°C			

0.75Ω、双路 SPDT 音频开关， 具有集成比较器

ELECTRICAL CHARACTERISTICS (continued)

($V_{CC} = +2.7V$ to $+5.5V$, $T_A = -40^{\circ}C$ to $+85^{\circ}C$, unless otherwise noted. Typical values are at $V_{CC} = +3.0V$, $T_A = +25^{\circ}C$, unless otherwise noted.) (Note 2)

PARAMETER	SYMBOL	CONDITIONS	MIN	TYP	MAX	UNITS	
Turn-Off Time	t_{OFF}	$V_{CC} = 2.7V$, $V_{NO_}$ or $V_{NC_} = 1.5V$, $R_L = 300\Omega$, $C_L = 50pF$ (Figure 1)	$T_A = +25^{\circ}C$		30	40	ns
			$T_A = -40^{\circ}C$ to $+85^{\circ}C$			60	
Break-Before-Make Time Delay (Note 3)	t_D	$V_{CC} = 2.7V$, $V_{NO_}$ or $V_{NC_} = 1.5V$, $R_L = 50\Omega$, $C_L = 50pF$ (Figure 2)	$T_A = +25^{\circ}C$		15		ns
			$T_A = -40^{\circ}C$ to $+85^{\circ}C$		2		
Charge Injection	Q	$V_{COM_} = 1.5V$, $R_S = 0\Omega$, $C_L = 1.0nF$ (Figure 3)		170		pC	
Off-Isolation (Note 6)		$f = 100kHz$, $V_{COM_} = 1V_{RMS}$, $R_L = 50\Omega$, $C_L = 5pF$ (Figure 4)		-75		dB	
Crosstalk	V_{CT}	$f = 100kHz$, $V_{COM_} = 1V_{RMS}$, $R_L = 50\Omega$, $C_L = 5pF$ (Figure 4)		-93		dB	
-3dB Bandwidth	BW	Signal = 0dBm, $R_L = 50\Omega$, $C_L = 5pF$ (Figure 4)		38		MHz	
Total Harmonic Distortion	THD	$f = 20Hz$ to $20kHz$, $V_{COM_} = 1V + 2V_{P-P}$, $R_L = 32\Omega$		0.07		%	
$NO_/NC_$ Off-Capacitance	C_{OFF}	$f = 1MHz$ (Figure 5)		50		pF	
COM On-Capacitance	C_{ON}	$f = 1MHz$ (Figure 5)		150		pF	
DIGITAL I/O (IN₋)							
Input-Logic High Voltage	V_{IH}	$V_{CC} = 2V$ to $3.6V$	1.4			V	
		$V_{CC} = 3.6V$ to $5.5V$	1.8				
Input-Logic Low Voltage	V_{IL}	$V_{CC} = 2V$ to $3.6V$			0.5	V	
		$V_{CC} = 3.6V$ to $5.5V$			0.8		
Input Leakage Current	I_{IN}	$V_{IN_} = 0$ or $5.5V$	-0.5		+0.5	μA	
COMPARATOR							
Comparator Range			0		5.5	V	
Comparator Threshold		$V_{CC} = 2V$ to $5.5V$, falling input	$0.3 \times V_{CC}$	$0.33 \times V_{CC}$	$0.36 \times V_{CC}$	V	
Comparator Hysteresis		$V_{CC} = 2V$ to $5.5V$		50		mV	
Comparator Output High Voltage		$I_{SOURCE} = 1mA$	$V_{CC} - 0.4V$			V	
Comparator Output Low Voltage		$I_{SINK} = 1mA$			0.4	V	
Comparator Switching Time		Rising input (Figure 6)		2.5		μs	
		Falling input (Figure 6)		0.5			

Note 2: Specifications are 100% tested at $T_A = +85^{\circ}C$ only, and guaranteed by design and characterization over the specified temperature range.

Note 3: Guaranteed by design and characterization; not production tested.

Note 4: $\Delta R_{ON} = R_{ON(MAX)} - R_{ON(MIN)}$.

Note 5: Flatness is defined as the difference between the maximum and minimum value of on-resistance as measured over the specified analog signal ranges.

Note 6: Off-Isolation = $20 \log_{10} (V_{COM_} / V_{NO_})$, $V_{COM_}$ = output, $V_{NO_}$ = input to off switch.

0.75Ω、双路 SPDT 音频开关， 具有集成比较器

典型工作特性

($V_{CC} = 3.0V$, $T_A = +25^\circ C$, unless otherwise noted.)

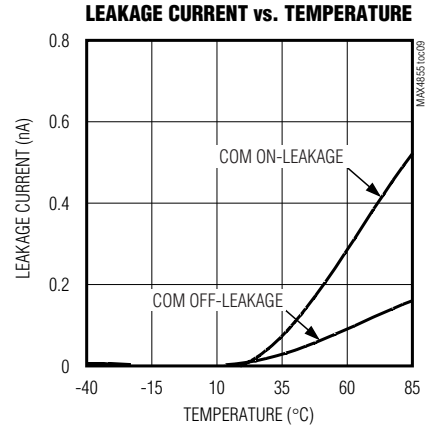
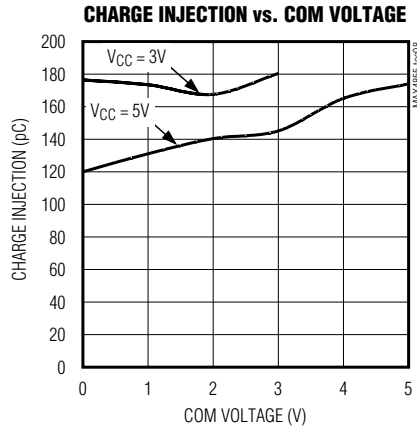
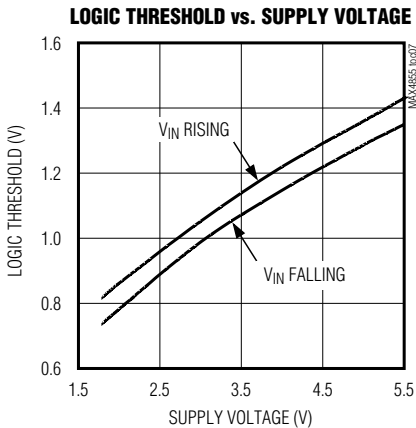
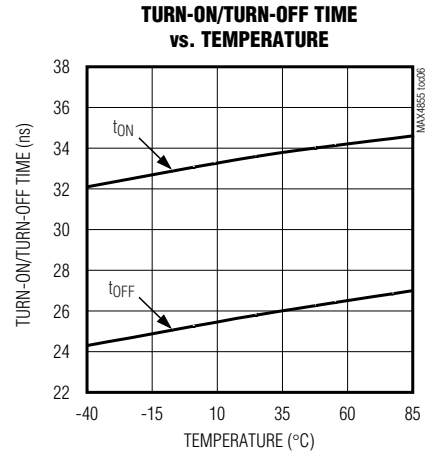
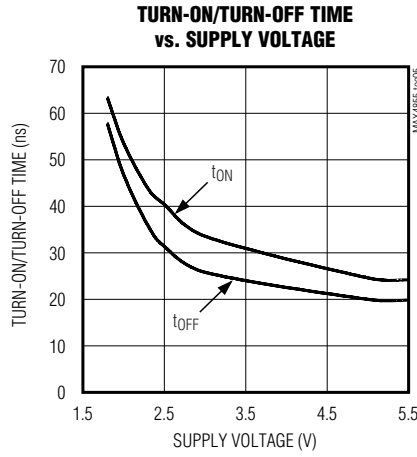
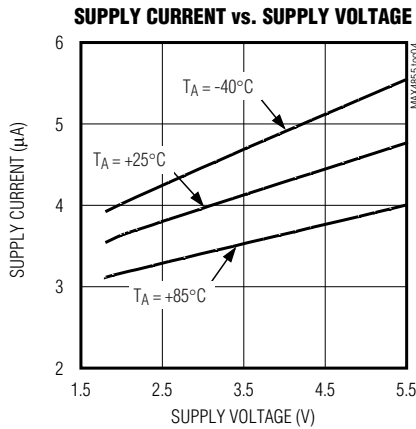
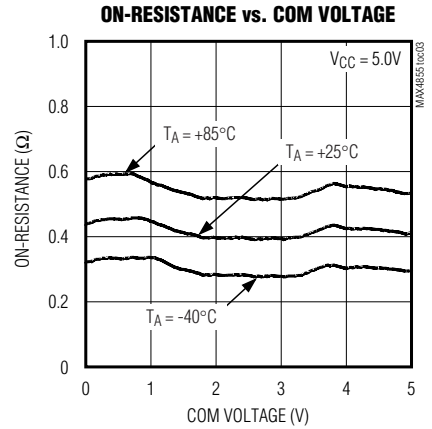
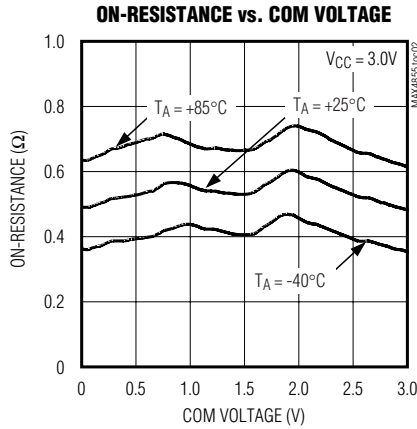
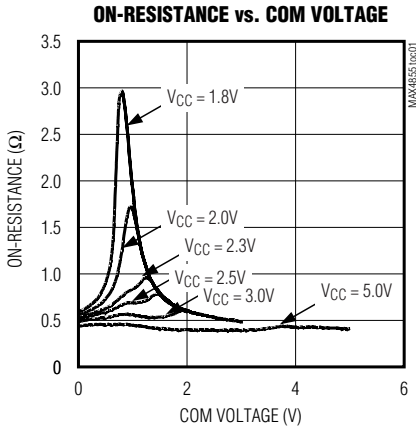

0.75Ω、双路 SPDT 音频开关， 具有集成比较器

典型工作特性(续)

($V_{CC} = 3.0V$, $T_A = +25^{\circ}C$, unless otherwise noted.)

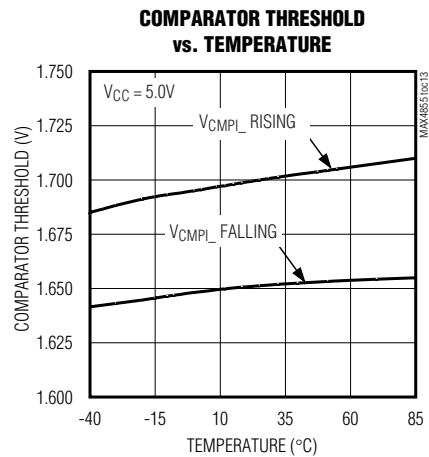
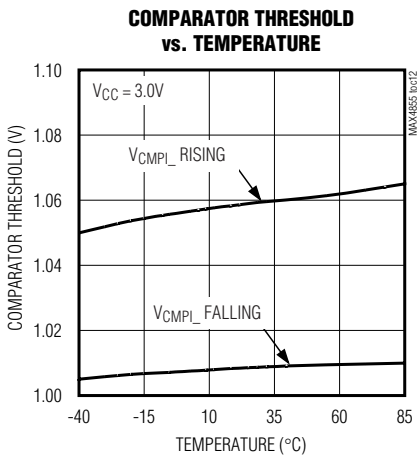
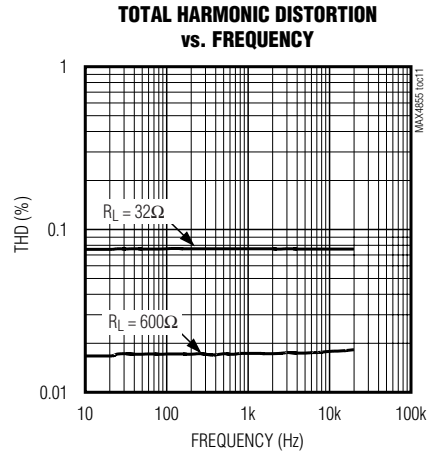
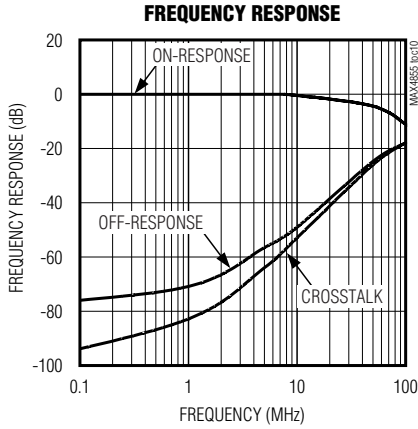

0.75Ω、双路 SPDT 音频开关， 具有集成比较器

引脚说明

引脚	名称	功能
1, 8	N.C.	未接。内部无连接。
2	CIN1	比较器 1 的反相输入
3	CIN2	比较器 2 的反相输入
4	COM1	模拟开关 1 的公共端
5	NO1	模拟开关 1 的常开端
6	GND	地
7	NC2	模拟开关 2 的常闭端
9	IN2	模拟开关 2 的数字控制输入。IN2 为逻辑低电平时接通 COM2 和 NC2；为逻辑高电平时接通 COM2 和 NO2。
10	COM2	模拟开关 2 的公共端
11	COU1	比较器 1 的输出
12	NO2	模拟开关 2 的常开端
13	COU2	比较器 2 的输出
14	VCC	电源电压。用一个尽可能靠近该引脚的 0.01μF 电容旁路至 GND。
15	IN1	模拟开关 1 的数字控制输入。IN1 为逻辑低电平时接通 COM1 和 NC1；为逻辑高电平时接通 COM1 和 NO1。
16	NC1	模拟开关 1 的常闭端
EP	—	裸露焊盘。接至 PC 板地层。

详细说明

MAX4855 为双路 SPDT、低导通电阻、低电压模拟开关，采用 +2V 到 +5.5V 电源供电，并可处理满摆幅信号。此外，MAX4855 还集成了两个内部比较器，可用于耳机或静音检测。比较器的门限值由内部设置，约为 V_{CC} 的 1/3。

应用信息

数字控制输入

逻辑输入 (IN₁) 可接受高达 +5.5V 的电压，即使电源电压低于该电平。例如， V_{CC} 电源为 +3.3V 时，IN₁ 可以低至 GND，也可以高至 +5.5V，这样就允许多种逻辑电平共存于同一系统中。满摆幅驱动 IN₁ 可使功耗降至最低。对于 +2V 供电电压，逻辑门限值为 0.5V (低) 和 1.4V (高)；对于 +5V 供电电压，逻辑门限值为 0.8V (低) 和 1.8V (高)。

模拟信号电平

当模拟输入信号在整个供电电压范围内变化时这些开关的导通电阻变化极小 (见典型工作特性)。这些开关都是双向的，因此 NO₁、NC₁ 和 COM₁ 既能做输入也能做输出。

比较器

比较器的同相端在内部设置为 $V_{CC}/3$ 。当反相端 (CIN₁) 低于该门限值 ($V_{CC}/3$) 时，比较器的输出 (COU₁) 为高。当 CIN₁ 上升到超过 $V_{CC}/3$ 时，COU₁ 变低。

可利用比较器的门限值实现耳机检测功能，这是因为耳机音频信号在典型情况下是偏置到 $V_{CC}/2$ 的。

供电顺序

警告： 加载电压不要超过极限参数，因为超过该值可能引起器件永久损坏。

对于所有 CMOS 器件，推荐使用正确的供电顺序。总是在加模拟信号之前先加 V_{CC} ，特别是在模拟信号没有限流的情况下。

0.75Ω、双路 SPDT 音频开关， 具有集成比较器

测试电路/时序图

MAX4855



图 1. 开关时间



图 2. 先断后合的间隔

0.75Ω、双路 SPDT 音频开关， 具有集成比较器

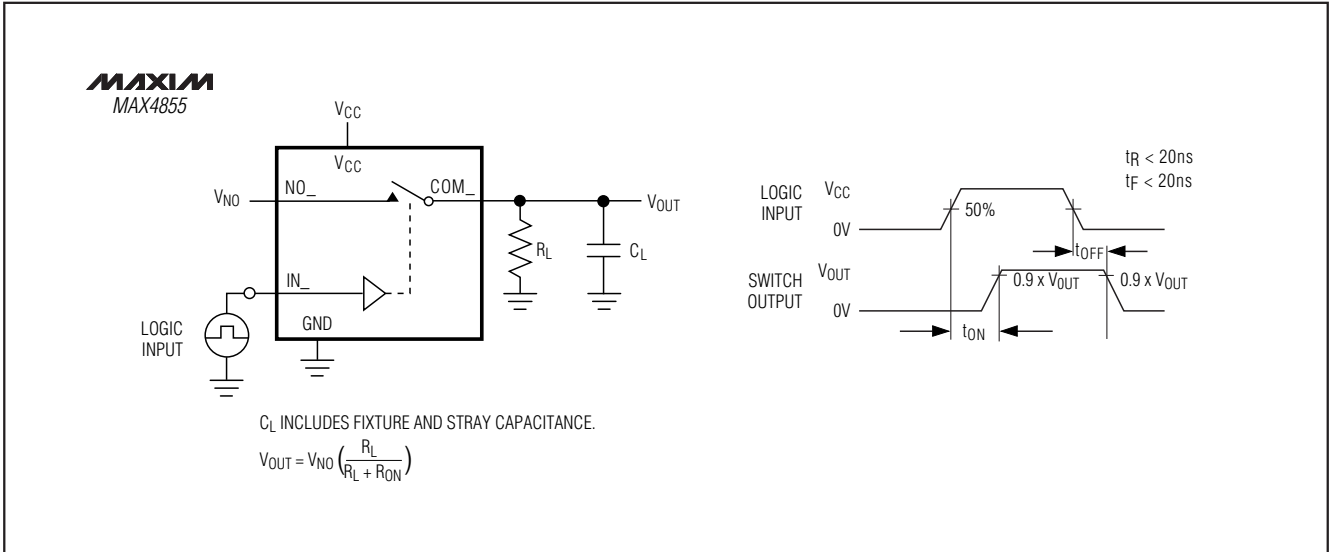

图 3. 电荷注入

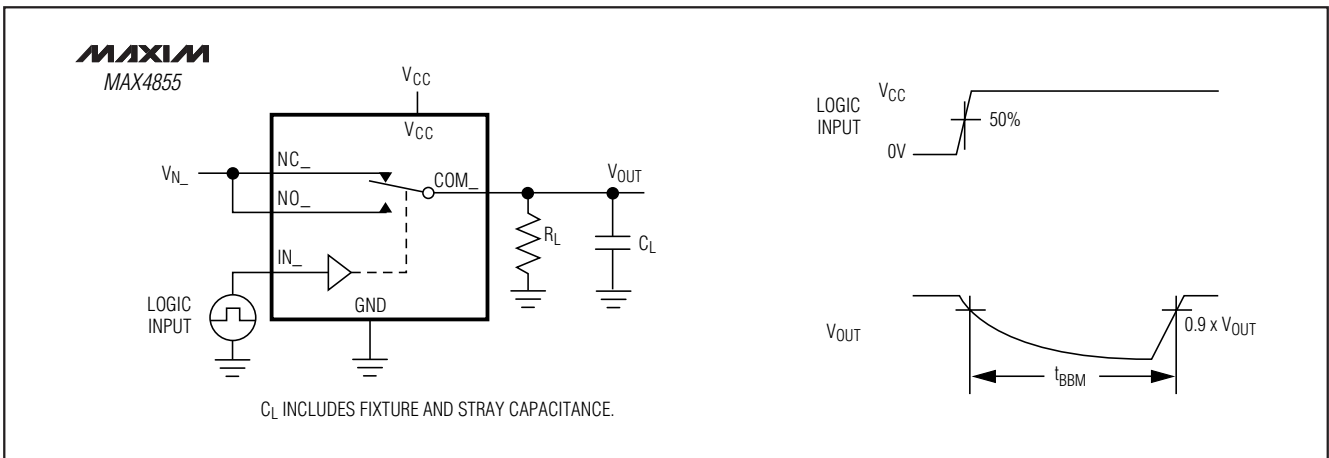

图 4. 导通损耗、关断隔离和串扰

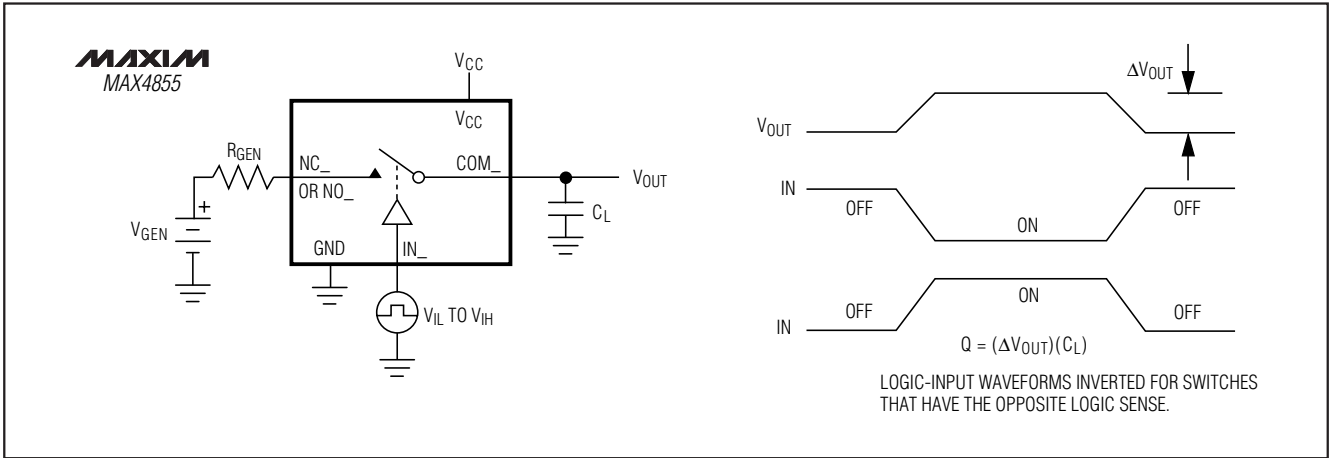

图 5. 通道关/开电容

0.75Ω、双路 SPDT 音频开关， 具有集成比较器

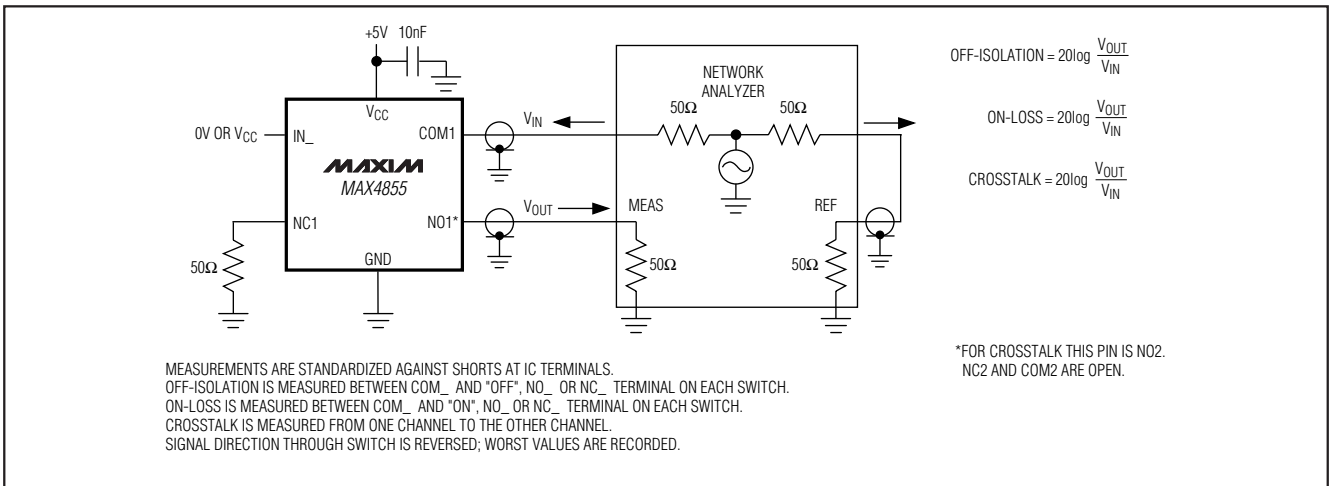

图 6. 比较器切换时间

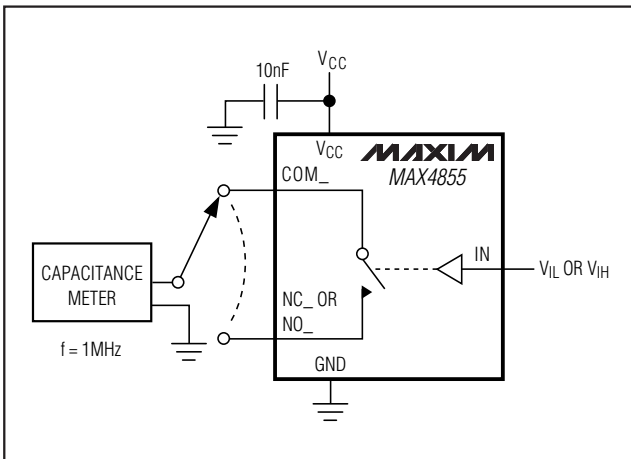
典型工作电路

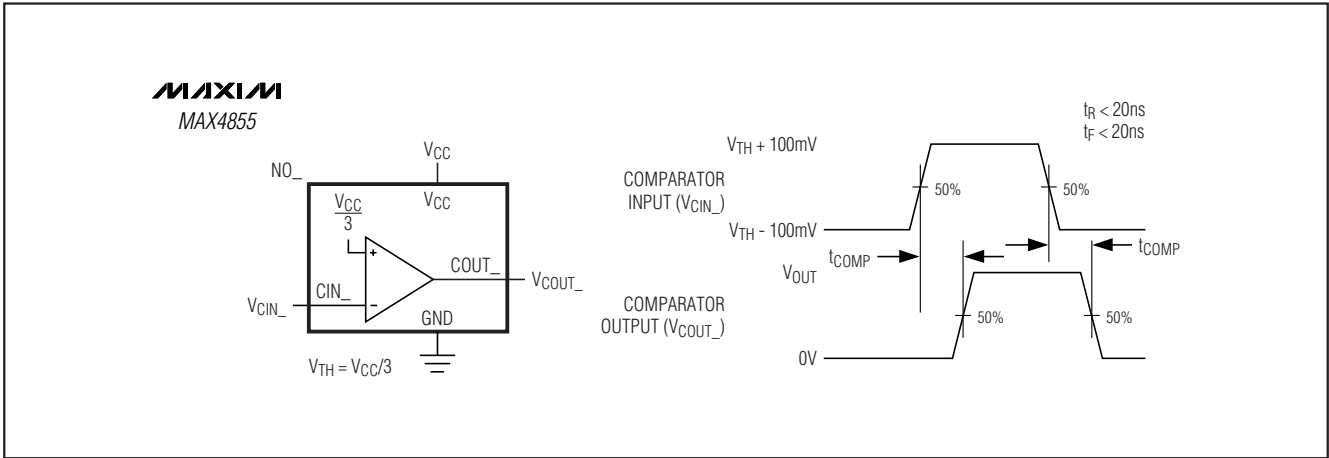
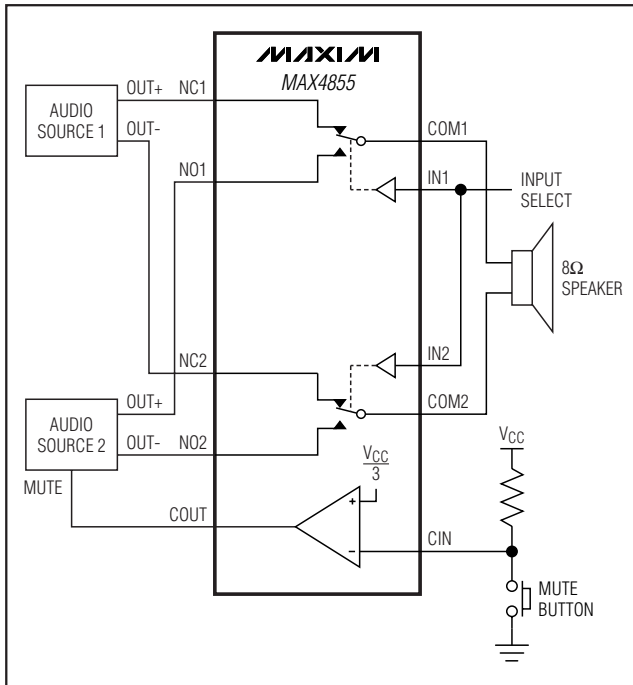

芯片信息

TRANSISTOR COUNT: 735
PROCESS: CMOS

0.75Ω、双路 SPDT 音频开关， 具有集成比较器

封装信息

(本数据资料提供的封装图可能不是最近的规格，如需最近的封装外型信息，请查询 www.maxim-ic.com.cn/packages。)

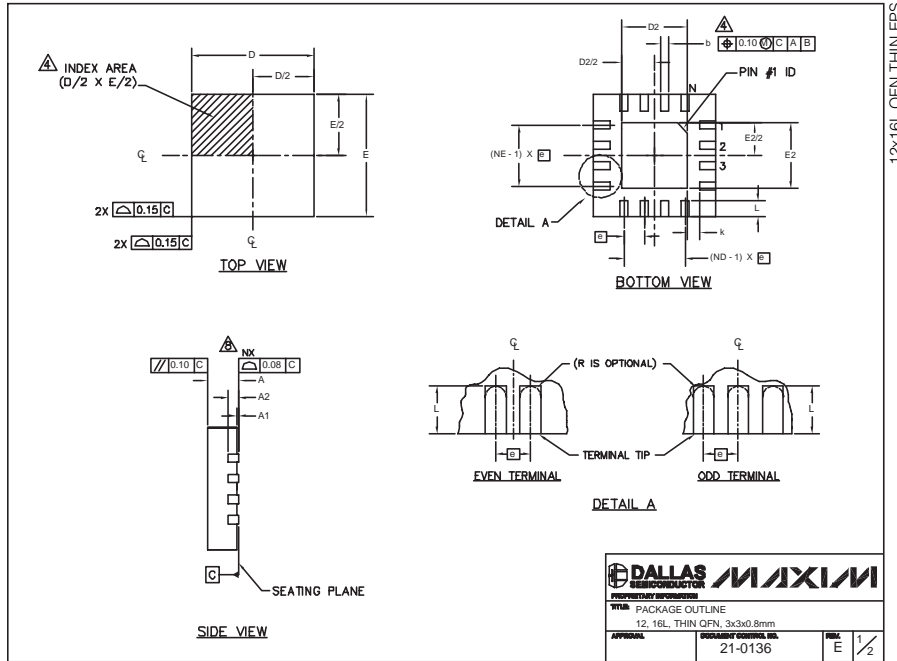

PKG	12L 3x3			16L 3x3		
REF.	MIN.	NOM.	MAX.	MIN.	NOM.	MAX.
A	0.70	0.75	0.80	0.70	0.75	0.80
b	0.20	0.25	0.30	0.20	0.25	0.30
D	2.90	3.00	3.10	2.90	3.00	3.10
E	2.90	3.00	3.10	2.90	3.00	3.10
e	0.50 BSC.			0.50 BSC.		
L	0.45	0.55	0.65	0.30	0.40	0.60
N	12			16		
ND	3			4		
NE	3			4		
A1	0	0.02	0.05	0	0.02	0.05
A2	0.20 REF			0.20 REF		
k	0.25	-	-	0.25	-	-

PKG. CODES	D2			E2			PIN ID	JEDEC	DOWN BONDS ALLOWED
	MIN.	NOM.	MAX.	MIN.	NOM.	MAX.			
T1233-1	0.95	1.10	1.25	0.95	1.10	1.25	0.35 x 45°	WEED-1	NO
T1233-3	0.95	1.10	1.25	0.95	1.10	1.25	0.35 x 45°	WEED-1	YES
T1833-1	0.85	1.10	1.25	0.85	1.10	1.25	0.35 x 45°	WEED-2	NO
T1833-2	0.85	1.10	1.25	0.95	1.10	1.25	0.35 x 45°	WEED-2	YES
T1833F-3	0.85	0.80	0.95	0.85	0.80	0.95	0.225 x 45°	WEED-2	N/A
T1833-4	0.85	1.10	1.25	0.95	1.10	1.25	0.35 x 45°	WEED-2	NO

NOTES:

- DIMENSIONING & TOLERANCING CONFORM TO ASME Y14.5M-1994.
- ALL DIMENSIONS ARE IN MILLIMETERS. ANGLES ARE IN DEGREES.
- N IS THE TOTAL NUMBER OF TERMINALS.
- THE TERMINAL #1 IDENTIFIER AND TERMINAL NUMBERING CONVENTION SHALL CONFORM TO JEDEC 95-1 SPP-012. DETAILS OF TERMINAL #1 IDENTIFIER ARE OPTIONAL, BUT MUST BE LOCATED WITHIN THE ZONE INDICATED. THE TERMINAL #1 IDENTIFIER MAY BE EITHER A MOLD OR MARKED FEATURE.
- DIMENSION L APPLIES TO METALLIZED TERMINAL AND IS MEASURED BETWEEN 0.20 mm AND 0.25 mm FROM TERMINAL TIP.
- ND AND NE REFER TO THE NUMBER OF TERMINALS ON EACH D AND E SIDE RESPECTIVELY.
- DEPOPULATION IS POSSIBLE IN A SYMMETRICAL FASHION.
- COPLANARITY APPLIES TO THE EXPOSED HEAT SINK SLUG AS WELL AS THE TERMINALS.
- DRAWING CONFORMS TO JEDEC MO220 REVISION C.

Maxim 不对 Maxim 产品以外的任何电路使用负责，也不提供其专利许可。Maxim 保留在任何时间、没有任何通报的前提下修改产品资料和规格的权利。

10 Maxim Integrated Products, 120 San Gabriel Drive, Sunnyvale, CA 94086 (408) 737-7600