

SINGLE-CHIP, LI-ION AND LI-POL CHARGER IC WITH AUTONOMOUS USB-PORT AND AC-ADAPTER SUPPLY MANAGEMENT (bqTINY™ -II)

FEATURES

- **Small 3 mm × 3 mm MLP Package**
- **Charges and Powers Systems from Either AC Adapter or USB With Autonomous Power-Source Selection**
- **Integrated USB Control With Selectable 100 mA and 500 mA Charge Rates**
- **Ideal for Low-Dropout Charger Designs for Single-Cell Li-Ion or Li-Pol Packs in Space Limited Portable Applications**
- **Integrated Power FET and Current Sensor for Up to 1-A Charge Applications From AC Adapter**
- **Precharge Conditioning With Safety Timer**
- **Power Good (AC Adapter Present) Status Output**
- **Optional Battery Temperature Monitoring Before and During Charge**
- **Automatic Sleep Mode for Low-Power Consumption**

APPLICATIONS

- PDAs, MP3 Players
- Digital Cameras
- Internet Appliances
- Smartphones

DESCRIPTION

The bqTINY-II series are highly integrated and flexible Li-Ion linear charge and system power management devices targeted at space limited charger applications. The bqTINY-II series offer integrated USB-port and ac-adapter supply management with autonomous power-source selection, power FET and current sensor, high-accuracy current and voltage regulation, charge status, and charge termination, in a single monolithic device.

The bqTINY-II automatically selects the USB-Port or the ac-adapter as the power source for the system. In the USB configuration, the host can select from the two preset charge rates of 100 mA and 500 mA. In the ac-adapter configuration an external resistor sets the magnitude of the system or charge current.

The bqTINY-II charges the battery in three phases: conditioning, constant current, and constant voltage. Charge is terminated based on minimum current. An internal charge timer provides a backup safety for charge termination. The bqTINY-II automatically re-starts the charge if the battery voltage falls below an internal threshold. The bqTINY-II automatically enters sleep mode when both supplies are removed.

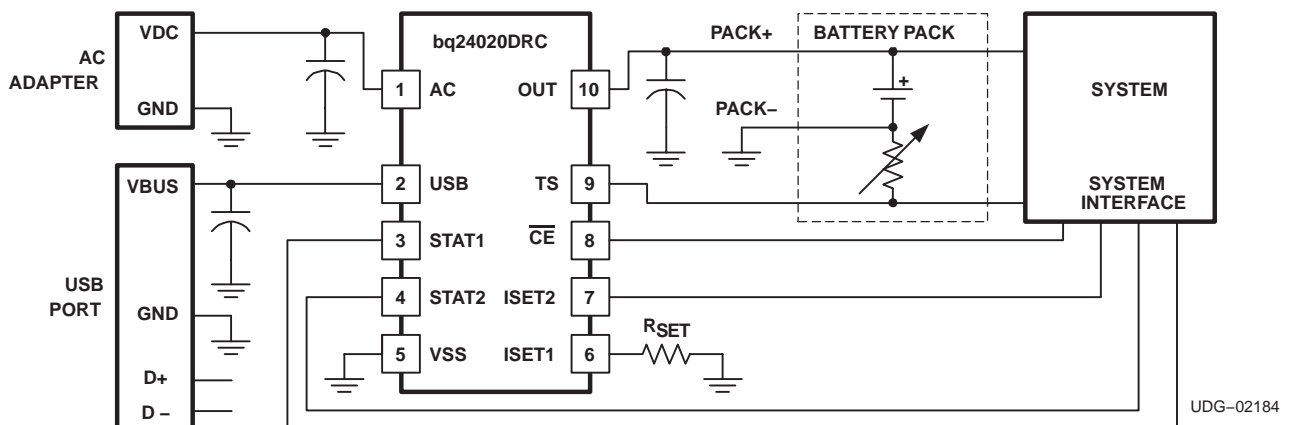

Please be aware that an important notice concerning availability, standard warranty, and use in critical applications of Texas Instruments semiconductor products and disclaimers thereto appears at the end of this data sheet.

bqTINY is a trademark of Texas Instruments Incorporated.

DESCRIPTION (CONTINUED)

In addition to the standard features, different versions of the bqTINY-II offer a multitude of additional features. These include temperature sensing input for detecting hot or cold battery packs; power good (PG) output indicating the presence of input power; a TTL-level charge enable input (\overline{CE}) used to disable or enable the charge process; and a TTL-level timer and taper-detect enable (\overline{TTE}) input used to disable or enable the fast-charge timer and charge termination.



These devices have limited built-in ESD protection. The leads should be shorted together or the device placed in conductive foam during storage or handling to prevent electrostatic damage to the MOSFET gates.

ORDERING INFORMATION

T _J	CHARGE REGULATION VOLTAGE (V) ⁽¹⁾	OPTIONAL FUNCTIONS ⁽¹⁾	FAST-CHARGE TIMER (Hours)	TAPER TIMER	USB TAPER THRESHOLD	PART NUMBER ⁽²⁾	MARKINGS
–40°C to 125°C	4.2	\overline{CE} and TS	5	Yes	10% of ISET1 Level	bq24020DRCR	AZS
	4.2	\overline{PG} and \overline{CE}	5	Yes	10% of ISET1 Level	bq24022DRCR	AZU
	4.2	\overline{CE} and \overline{TTE}	5	Yes	10% of ISET1 Level	bq24023DRCR	AZV
	4.2	\overline{TTE} and TS	5	Yes	10% of ISET1 Level	bq24024DRCR	AZW
	4.2	\overline{CE} and TS	7	Yes	10% of ISET1 Level	bq24025DRCR	AZX
	4.2	\overline{TE} and TS	7	No	10% of selected USB charge rate	bq24026DRCR	ANR

(1) The DRC package is available taped and reeled only in quantities of 3,000 devices per reel.

DISSIPATION RATINGS

PACKAGE	θ_{JA}	T _A < 40°C POWER RATING	DERATING FACTOR ABOVE T _A = 25°C
DRC ⁽¹⁾	46.87 °C/W	1.5 W	0.021 W/°C

(1) This data is based on using the JEDEC High-K board and the exposed die pad is connected to a copper pad on the board. This is connected to the ground plane by a 2x3 via matrix.

ABSOLUTE MAXIMUM RATINGS

over operating free-air temperature range unless otherwise noted⁽¹⁾

		bq24020, bq24022 bq24023, bq24024 bq24025, bq24026	UNITS
Input voltage ⁽²⁾	AC, \overline{CE} , ISET1, ISET2, OUT, \overline{PG} , STAT1, STAT2, TE, TS, TTE, USB	–0.3 to 7.0	V
Output sink/source current	STAT1, STAT2, \overline{PG}	15	mA
Output current	TS	200	μA
Output current	OUT	1.5	A
Operating free-air temperature range, T _A		–40 to 125	°C
Junction temperature range, T _J			
Storage temperature, T _{stg}			
Lead temperature 1,6 mm (1/16 inch) from case for 10 seconds		300	

(1) Stresses beyond those listed under “absolute maximum ratings” may cause permanent damage to the device. These are stress ratings only, and functional operation of the device at these or any other conditions beyond those indicated under “recommended operating conditions” is not implied. Exposure to absolute-maximum-rated conditions for extended periods may affect device reliability.

(2) All voltages are with respect to V_{SS}.

RECOMMENDED OPERATING CONDITIONS⁽¹⁾

	MIN	NOM	MAX	UNIT
Supply voltage (from AC input), V _{CC}	4.5		6.5	V
Supply voltage (from USB input), V _{CC}	4.35		6.5	V
Operating junction temperature range, T _J	–40		125	°C

ELECTRICAL CHARACTERISTICS

 over $0^{\circ}\text{C} \leq T_J \leq 125^{\circ}\text{C}$ and recommended supply voltage, unless otherwise noted

PARAMETER	TEST CONDITIONS	MIN	TYP	MAX	UNIT
INPUT CURRENT					
VCC current, $I_{CC}(VCC)$	$V_{CC} > V_{CC}(\text{min})$		1.2	2.0	mA
Sleep current, $I_{CC}(\text{SLP})$	Sum of currents into OUT pin, $V_{CC} < V_{\text{SLP}}$		2	5	μA
Standby current, $I_{CC}(\text{STBY})$	CE = High, $0^{\circ}\text{C} \leq T_J \leq 85^{\circ}\text{C}$			150	
Input current on OUT pin, $I_{B}(\text{OUT})$	Charge DONE, $V_{CC} > V_{CC}(\text{MIN})$		1	5	
Input current on CE pin, $I_{B}(\text{CE})$				1	
Input bias current on TTE pin, $I_{B}(\text{TTE})$				1	
Input bias current on TE pin, $I_{B}(\text{TE})$				1	
VOLTAGE REGULATION $V_{O}(\text{REG}) + V_{\text{DO-MAX}} \leq V_{CC}$, $I_{\text{TERM}} < I_{O}(\text{OUT}) \leq 1\text{ A}$					
Output voltage, $V_{O}(\text{REG})$			4.20		V
Voltage regulation accuracy	$T_A = 25^{\circ}\text{C}$		-0.35%	0.35%	
			-1%	1%	
AC dropout voltage ($V_{\text{AC}} - V_{\text{OUT}}$), V_{DO}	$V_{O}(\text{OUT}) = V_{O}(\text{REG})$, $V_{O}(\text{REG}) + V_{\text{DO-MAX}} \leq V_{CC}$, $I_{O}(\text{OUT}) = 1\text{ A}$		350	500	mV
USB dropout voltage ($V_{\text{USB}} - V_{\text{OUT}}$), V_{DO}	$V_{O}(\text{OUT}) = V_{O}(\text{REG})$ $V_{O}(\text{REG}) + V_{\text{DO-MAX}} \leq V_{CC}$, ISET2 = High		350	500	
		$V_{O}(\text{OUT}) = V_{O}(\text{REG})$ $V_{O}(\text{REG}) + V_{\text{DO-MAX}} \leq V_{CC}$, ISET2 = Low		60	100
CURRENT REGULATION					
AC output current range, $I_{O}(\text{OUT})^{(1)}$	$V_{I}(\text{OUT}) > V_{\text{LOWV}}$, $V_{\text{AC}} - V_{I}(\text{OUT}) > V_{\text{DO-MAX}}$, $V_{CC} \geq 4.5\text{ V}$,	50		1000	mA
USB output current range, $I_{O}(\text{OUT})$	$V_{CC}(\text{MIN}) \geq 4.5\text{ V}$, $V_{\text{USB}} - V_{I}(\text{OUT}) > V_{\text{DO-MAX}}$, $V_{I}(\text{OUT}) > V_{\text{LOWV}}$, ISET2 = Low	80		100	
	$V_{CC}(\text{MIN}) \geq 4.5\text{ V}$, $V_{\text{USB}} - V_{I}(\text{OUT}) > V_{\text{DO-MAX}}$, $V_{I}(\text{OUT}) > V_{\text{LOWV}}$, ISET2 = High	400		500	
Output current set voltage, V_{SET}	Voltage on ISET1 pin, $V_{CC} \geq 4.5\text{ V}$, $V_{\text{IN}} \geq 4.5\text{ V}$, $V_{I}(\text{OUT}) > V_{\text{LOWV}}$, $V_{\text{IN}} - V_{I}(\text{OUT}) > V_{\text{DO-MAX}}$	2.463	2.500	2.538	V
Output current set factor, K_{SET}	$50\text{ mA} \leq I_{O}(\text{OUT}) \leq 1\text{ A}$	307	322	337	
	$10\text{ mA} \leq I_{O}(\text{OUT}) < 50\text{ mA}$	296	320	346	
	$1\text{ mA} \leq I_{O}(\text{OUT}) < 10\text{ mA}$	246	320	416	
PRECHARGE AND SHORT-CIRCUIT CURRENT REGULATION					
Precharge to fast-charge transition threshold, V_{LOWV}	Voltage on OUT pin	2.8	3.0	3.2	V
Degitch time for fast-charge to precharge transition	$V_{CC}(\text{MIN}) \geq 4.5\text{ V}$, $t_{\text{FALL}} = 100\text{ ns}$, 10 mV overdrive $V_{I}(\text{OUT})$ decreasing below threshold	250	375	500	ms
Precharge range, $I_{O}(\text{PRECHG})^{(2)}$	$0\text{ V} < V_{I}(\text{OUT}) < V_{\text{LOWV}}$, $t < t_{\text{PRECHG}}$	5		100	mA
Precharge set voltage, V_{PRECHG}	Voltage on ISET1 pin, $0\text{ V} < V_{I}(\text{OUT}) > V_{\text{LOWV}}$, $V_{O}(\text{REG}) = 4.2\text{ V}$, $t < t_{\text{PRECHG}}$	240	255	270	mV

$$(1) \quad I_{O}(\text{OUT}) = \frac{(K_{\text{SET}} \times V_{\text{SET}})}{R_{\text{SET}}}$$

$$(2) \quad I_{O}(\text{PRECHG}) = \frac{(K_{\text{SET}} \times V_{\text{PRECHG}})}{R_{\text{SET}}}$$

ELECTRICAL CHARACTERISTICS(continued)

over 0°C ≤ T_J ≤ 125°C and recommended supply voltage, unless otherwise noted

PARAMETER		TEST CONDITIONS	MIN	TYP	MAX	UNIT
CHARGE TAPER AND TERMINATION DETECTION						
Charge taper detection range, I _(TAPER) ⁽³⁾		V _{I(OUT)} > V _(RCH) , t < t _(TAPER)	5		100	mA
USB-100 charge taper detection level	bq24026	V _{I(OUT)} > V _(RCH) , ISET2 = Low	6.5	9	11	
USB-500 charge taper detection level	bq24026	V _{I(OUT)} > V _(RCH) , ISET2 = High	32	44	55	
Charge taper detection set voltage, V _(TAPER)		Voltage on ISET1 pin, V _{O(REG)} = 4.2 V, V _{I(OUT)} > V _(RCH) , t < t _(TAPER)	235	250	265	mV
Charge termination detection set voltage, V _(TERM) ⁽⁴⁾		Voltage on ISET pin, V _{O(REG)} = 4.2 V, V _{I(OUT)} > V _(RCH)	11	18	25	
Deglitch time for TAPER detection, t _{TPRDET}		V _{CC(MIN)} ≥ 4.5 V, t _{FALL} = 100 ns charging current increasing or decreasing above and below, 10 mV overdrive	250	375	500	ms
Deglitch time for termination detection, t _{TRMDET}		V _{CC(MIN)} ≥ 4.5 V, t _{FALL} = 100 ns charging current decreasing below, 10 mV overdrive	250	375	500	
TEMPERATURE SENSE COMPARATOR						
Low-voltage threshold, V _(LTF)			2.475	2.500	2.525	V
High-voltage threshold, V _(HTF)			0.485	0.500	0.515	
Current source, I _(TS)			96	102	108	μA
Deglitch time for temperature fault, t _(DEGL)			250	375	500	ms
BATTERY RECHARGE THRESHOLD						
Recharge threshold, V _{RCH}			V _{O(REG)} -0.115	V _{O(REG)} -0.10	V _{O(REG)} -0.085	V
Deglitch time for recharge detect, t _(DEGL)		V _{CC(MIN)} ≥ 4.5 V, t _{FALL} = 100 ns decreasing below or increasing above threshold, 10 mV overdrive	250	375	500	ms
STAT1, STAT2, and PG OUTPUTS						
Low-level output saturation voltage, V _{OL}		I _O = 5 mA			0.25	V
ISET2, CHARGE ENABLE (CE), TIMER AND TERMINATION ENABLE (TTE), AND TIMER ENABLE (TE) INPUTS						
Low-level input voltage, V _{IL}		I _{IL} = 10 μA	0		0.4	V
High-level input voltage, V _{IH}		I _{IL} = 20 μA	1.4			
CE, TE or TTE low-level input current, I _{IL}			-1			μA
CE, TE or TTE high-level input current, I _{IH}					1	
ISET2 low-level input current, I _{IL}		I _{ISET2} = 0	-20			
ISET2 high-level input current, I _{IH}		I _{ISET2} = V _{CC}			40	V
ISET2 high-Z input current, I _{IH}					1	

(3)

$$I_{O(TAPER)} = \frac{(K_{(SET)} \times V_{(TAPER)})}{R_{SET}}$$

ELECTRICAL CHARACTERISTICS(continued)

 over $0^{\circ}\text{C} \leq T_J \leq 125^{\circ}\text{C}$ and recommended supply voltage, unless otherwise noted

PARAMETER		TEST CONDITIONS	MIN	TYP	MAX	UNIT
TIMERS						
Precharge time, $t(\text{PRECHG})$			1,620	1,800	1,930	s
Taper time, $t(\text{TAPER})$	bq24020 bq24022 bq24023 bq24024 bq24025		1,620	1,800	1,930	
	bq24020 bq24022 bq24023 bq24024		16,200	18,000	19,300	
Charge time, $t(\text{CHG})$	bq24025, bq24026		22,680	25,200	27,720	s
	Timer fault recovery current, $I(\text{FAULT})$		200			μA
SLEEP COMPARATOR						
Sleep-mode entry threshold voltage, $V(\text{SLP})$	$2.3\text{ V} \leq V_I(\text{OUT}) \leq V_O(\text{REG})$		$V_{CC} \leq V_I(\text{OUT}) + 80\text{ mV}$			V
Sleep mode exit threshold voltage, $V(\text{SLPEXIT})$	$2.3\text{ V} \leq V_I(\text{OUT}) \leq V_O(\text{REG})$		$V_{CC} \geq V_I(\text{OUT}) + 190\text{ mV}$			
Sleep mode deglitch time	AC and USB decreasing below threshold, $t_{\text{FALL}} = 100\text{ ns}$, 10 mV overdrive		250	375	500	ms
THERMAL SHUTDOWN THRESHOLDS						
Thermal trip threshold, $T(\text{SHTDWN})$			165			$^{\circ}\text{C}$
Thermal hysteresis			15			
UNDERVOLTAGE LOCKOUT						
Undervoltage lockout $V(\text{UVLO})$	Decreasing V_{CC}		2.4	2.5	2.6	V
Hysteresis			27			mV

$$(3) \quad I_{O(\text{TAPER})} = \frac{(K_{(\text{SET})} \times V_{(\text{TAPER})})}{R_{\text{SET}}}$$

$$(4) \quad I_{O(\text{TERM})} = \frac{(K_{(\text{SET})} \times V_{(\text{TERM})})}{R_{\text{SET}}}$$

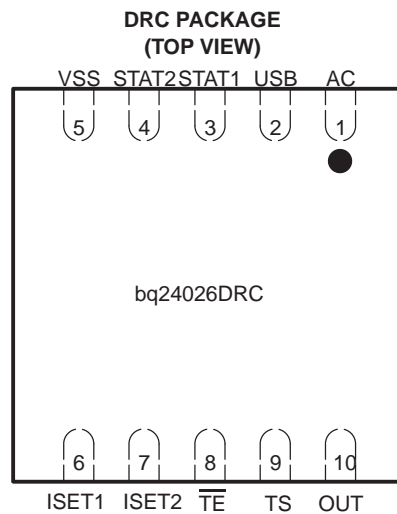
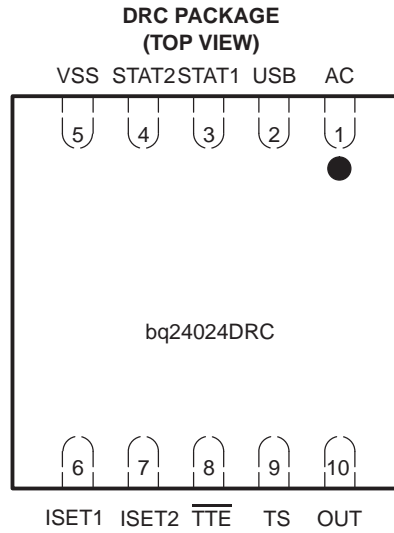
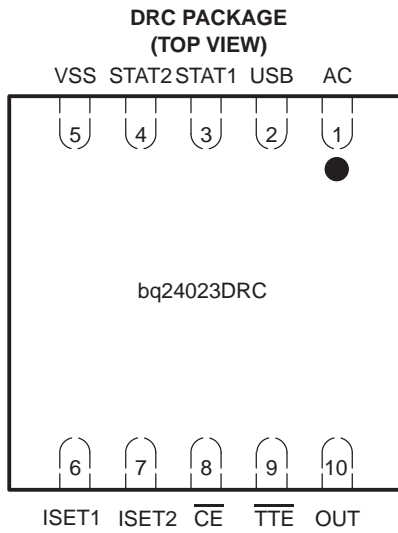
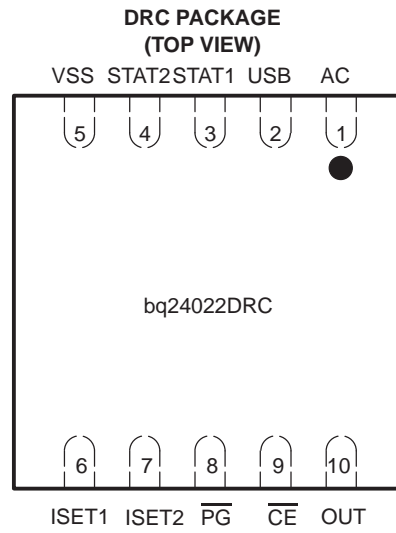
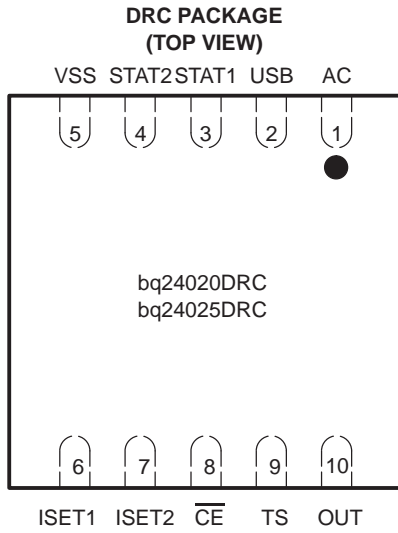

TERMINAL FUNCTIONS

NAME	TERMINAL					I/O	DESCRIPTION
	bq24020 bq24025	bq24022	bq24023	bq24024	bq24026		
AC	1	1	1	1	1	I	AC charge input voltage
$\overline{\text{CE}}$	8	9	8	–	–	I	Charge enable input (active low)
ISET1	6	6	6	6	6	I	Charge current set point for AC input and precharge and taper set point for both AC and USB
ISET2	7	7	7	7	7	I	Charge current set point for USB port (high=500 mA, Low=100 mA, hi-z=disable USB charge)
OUT	10	10	10	10	10	O	Charge current output
$\overline{\text{PG}}$	–	8	–	–	–	O	Powergood status output (active low)
STAT1	3	3	3	3	3	O	Charge status output 1 (open-drain)
STAT2	4	4	4	4	4	O	Charge status output 2 (open-drain)
$\overline{\text{TE}}$	–	–	–	–	8	I	Timer enable input (active low)
TS	9	–	–	9	9	I	Temperature sense input
$\overline{\text{TTE}}$	–	–	9	8	–	I	Timer and termination enable input (active low)
USB	2	2	2	2	2	I	USB charge input voltage
VSS	5	5	5	5	5	–	Ground input
Exposed Thermal Pad	pad	pad	pad	pad	pad	–	There is an internal electrical connection between the exposed thermal pad and VSS pin of the device. The exposed thermal pad must be connected to the same potential as the Vss pin on the printed circuit board. Do not use the thermal pad as the primary ground input for the device. VSS pin must be connected to ground at all times

FUNCTIONAL BLOCK DIAGRAM

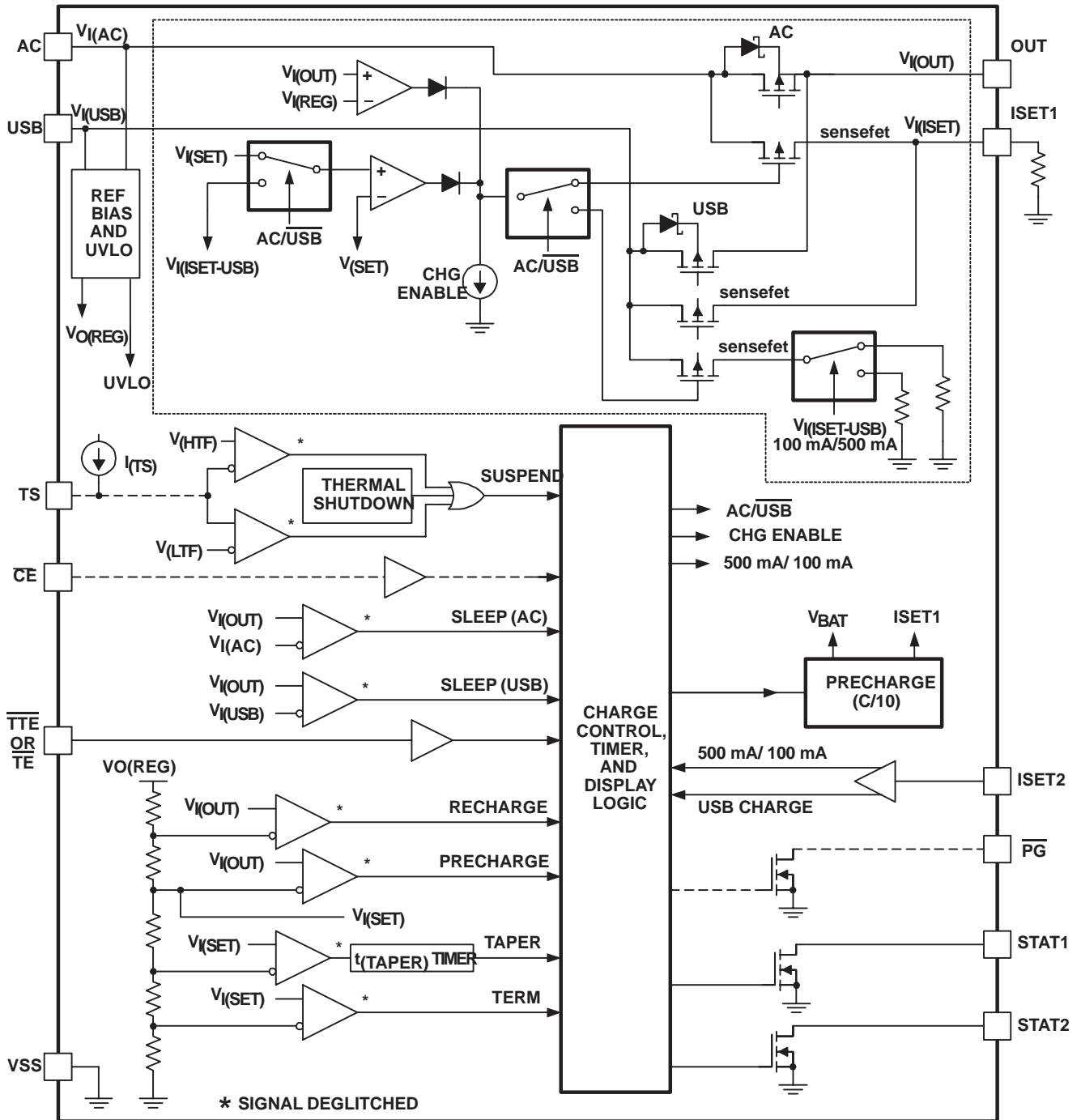

UDG-02185

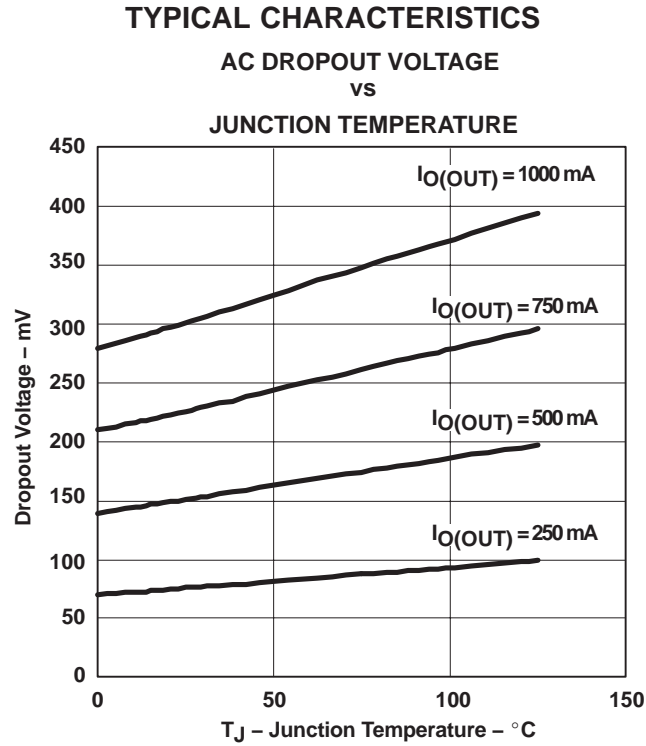

Figure 1

The bqTINYII supports a precision Li-Ion, Li-Pol charging system suitable for single-cells. Figure 3 shows a typical charge profile, application circuit and Figure 4 shows an operational flow chart.

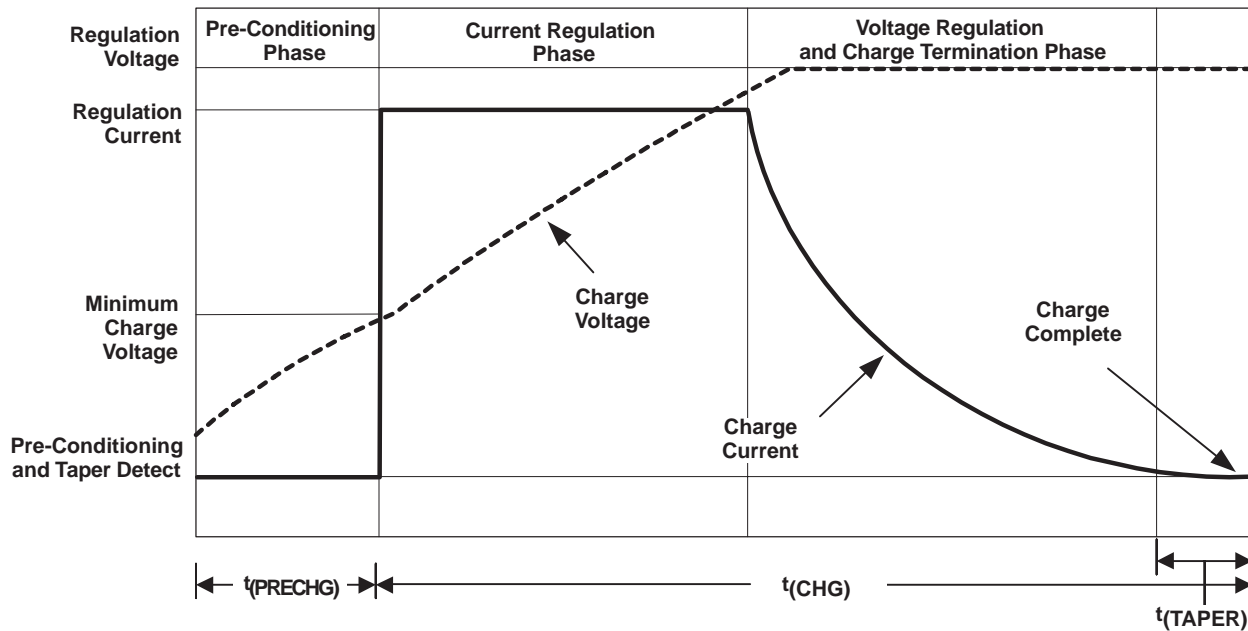
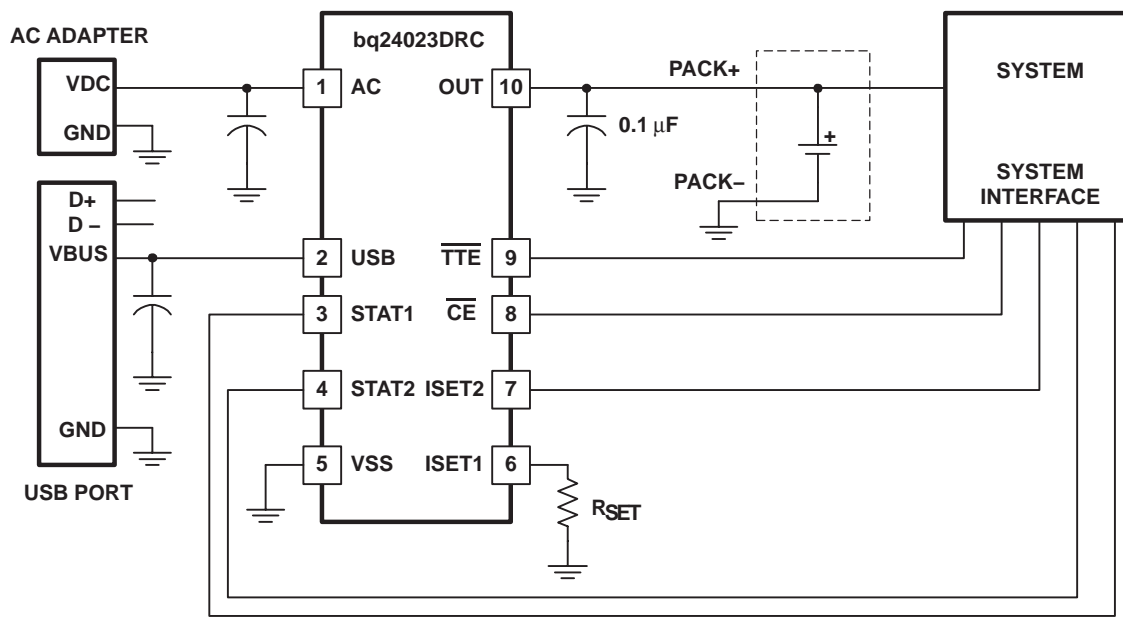

Figure 2. Typical Charging Profile

FUNCTIONAL DESCRIPTION



UDG-02184

Figure 3. Typical Application Circuit

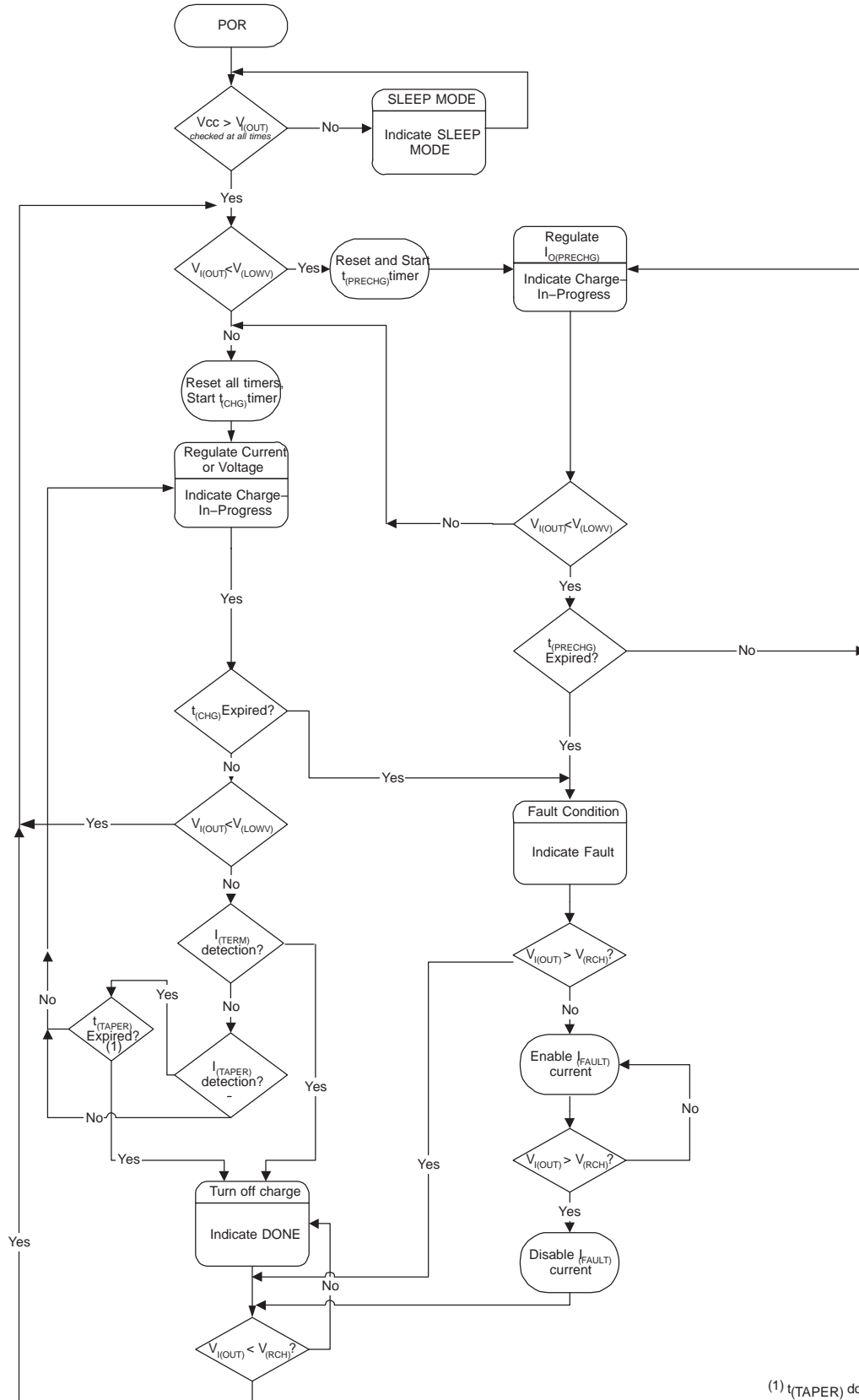

(1) $t_{(TAPER)}$ does not apply to bq24026

Figure 4. Operational Flow Chart

FUNCTIONAL DESCRIPTION

AUTONOMOUS POWER SOURCE SELECTION

As default the bqTINY-II attempts to charge from the AC input. If AC input is not present, the USB is selected. If both inputs are available, the AC adapter has the priority. See Figure 5 for details.

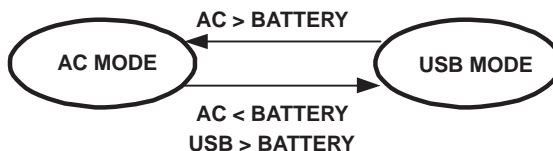

UDG-02187

Figure 5. Typical Charging Profile

TEMPERATURE QUALIFICATION (bq24020, bq24024, bq24025, and bq24026 only)

The bqTINY-II continuously monitors battery temperature by measuring the voltage between the TS and VSS pins. An internal current source provides the bias for most common 10-kΩ negative-temperature coefficient thermistors (NTC) (see Figure 6). The device compares the voltage on the TS pin against the internal $V_{(LTF)}$ and $V_{(HTF)}$ thresholds to determine if charging is allowed. Once a temperature outside the $V_{(LTF)}$ and $V_{(HTF)}$ thresholds is detected the device immediately suspend the charge. The device suspend charge by turning off the powerFET and holding the timer value (i.e. timers are NOT reset). Charge is resumed when the temperature returns to the normal range.

The allowed temperature range for 103AT type thermistor is 0°C to 45°C. However the user may modify these thresholds by adding two external resistors. See Figure 7.

BATTERY PRE-CONDITIONING

During a charge cycle if the battery voltage is below the $V_{(LOWV)}$ threshold, the bqTINY-II applies a precharge current, $I_{O(PRECHG)}$, to the battery. This feature revives deeply discharged cells. The resistor connected between the ISET1 and Vss, R_{SET} , determines the precharge rate. The $V_{(PRECHG)}$ and $K_{(SET)}$ parameters are specified in the specifications table. Note that this applies to both AC and USB charging.

$$I_{O(PRECHG)} = \frac{V_{(PRECHG)} \times K_{(SET)}}{R_{SET}} \quad (1)$$

The bqTINY-II activates a safety timer, $t_{(PRECHG)}$, during the conditioning phase. If $V_{(LOWV)}$ threshold is not reached within the timer period, the bqTINY-II turns off the charger and enunciates FAULT on the STATx pins. Please refer to the *TIMER FAULT RECOVERY* section for additional details.

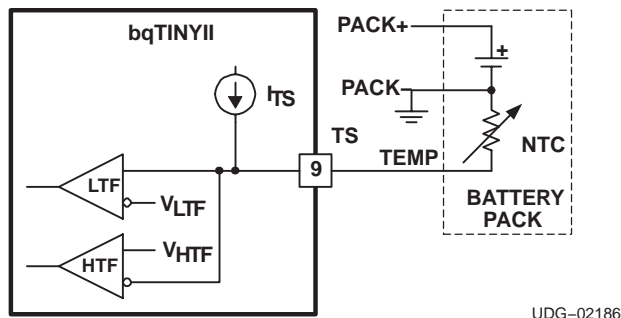

UDG-02186

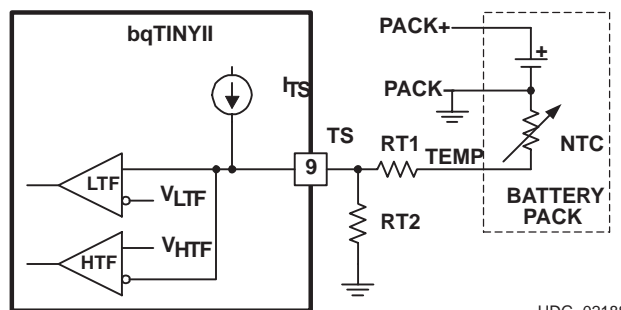

UDG-02188

Figure 6. Temperature Sensing Configuration

Figure 7. Temperature Sensing Thresholds

FUNCTIONAL DESCRIPTION

BATTERY CHARGE CURRENT

The bqTINY-II offers on-chip current regulation with programmable set point. The resistor connected between the ISET1 and V_{SS}, R_{SET}, determines the AC charge rate. The V_(SET) and K_(SET) parameters are specified in the specifications table.

$$I_{O(OUT)} = \frac{V_{(SET)} \times K_{(SET)}}{R_{SET}} \quad (2)$$

When charging from a USB port, the host controller has the option of selecting either 100 mA or 500 mA charge rate using ISET2 pin. A low-level signal sets current at 100 mA and a high level signal sets current at 500 mA. A high-Z input disables USB charging.

BATTERY VOLTAGE REGULATION

The voltage regulation feedback is through the OUT pin. This input is tied directly to the positive side of the battery pack. The bqTINY-II monitors the battery-pack voltage between the OUT and V_{SS} pins. When the battery voltage rises to V_{O(REG)} threshold, the voltage regulation phase begins and the charging current begins to taper down.

As a safety backup, the bqTINY-II also monitors the charge time in the charge mode. If charge is not terminated within this time period, t_(CHG), the bqTINY-II turns off the charger and enunciates FAULT on the STATx pins. Please refer to the *TIMER FAULT RECOVERY* section for additional details.

CHARGE TAPER DETECTION, TERMINATION AND RECHARGE

The bqTINY-II monitors the charging current during the voltage regulation phase. Once the taper threshold, I_(TAPER), is detected the bqTINY-II initiates the taper timer, t_(TAPER). Charge is terminated after the timer expires. The resistor connected between the ISET1 and V_{SS}, R_{SET}, determines the taper detection level. The V_(TAPER) and K_(SET) parameters are specified in the specifications table. Note that this applies to both AC and USB charging.

$$I_{(TAPER)} = \frac{V_{(TAPER)} \times K_{(SET)}}{R_{SET}} \quad (3)$$

The bqTINY-II resets the taper timer in the event that the charge current returns above the taper threshold, I_(TAPER).

In addition to the taper current detection, the bqTINY-II terminates charge in the event that the charge current falls below the I_(TERM) threshold. This feature allows for quick recognition of a battery removal condition or insertion of a fully charged battery. Note that charge timer and taper timer are bypassed for this feature. The resistor connected between the ISET1 and V_{SS}, R_{SET}, determines the taper detection level. The V_(TERM) and K_(SET) parameters are specified in the specifications table. Note that this applies to both AC and USB charging.

$$I_{(TERM)} = \frac{V_{(TERM)} \times K_{(SET)}}{R_{SET}} \quad (4)$$

After charge termination, the bqTINY-II re-starts the charge once the voltage on the OUT pin falls below the V_(RCH) threshold. This feature keeps the battery at full capacity at all times.

NOTE ON bq24026

The bq24026 monitors the charging current during the voltage regulation phase. Once the taper threshold, I_(TAPER), is detected the bq24026 terminates the charge. There is no taper timer, t_(TAPER) for this version.

The resistor connected between the ISET1 and V_{SS}, R_{SET}, determines the taper detection level for AC input. For USB charge, taper level is fixed at 10% of the 100- or 500-mA charge rate.

Also note that there is I_(TERM) detection in bq24026.

FUNCTIONAL DESCRIPTION

SLEEP MODE

The bqTINY-II enters the low-power sleep mode if both AC and USB are removed from the circuit. This feature prevents draining the battery during the absence of input supply.

CHARGE STATUS OUTPUTS

The open-drain STAT1 and STAT2 outputs indicate various charger operations as shown in the following table. These status pins can be used to drive LEDs or communicate to the host processor. Note that OFF indicates the open-drain transistor is turned off.

Table 1. Status Pins Summary

CHARGE STATE	STAT1	STAT2
Precharge in progress	ON	ON
Fast charge in progress	ON	OFF
Charge done	OFF	ON
Charge suspend (temperature)	OFF	OFF
Timer fault	OFF	OFF
Sleep mode	OFF	OFF

(†) OFF means the open-drain output transistor on the STAT1 and STAT2 pins is in an off state.

$\overline{\text{PG}}$ OUTPUT

The open-drain $\overline{\text{PG}}$ (Power Good) indicates when the AC adapter is present. The output turns ON when a valid voltage is detected. This output is turned off in the sleep mode. The $\overline{\text{PG}}$ pin can be used to drive an LED or communicate to the host processor.

$\overline{\text{CE}}$ INPUT (CHARGE ENABLE)

The $\overline{\text{CE}}$ digital input is used to disable or enable the charge process. A low-level signal on this pin enables the charge and a high-level signal disables the charge and places the device in a low-power mode. A high-to-low transition on this pin also resets all timers and timer fault conditions. Note that this applies to both AC and USB charging.

$\overline{\text{TTE}}$ INPUT (TIMER AND TERMINATION ENABLE)

The $\overline{\text{TTE}}$ digital input is used to disable or enable the fast-charge timer and charge taper detection. A low-level signal on this pin enables the fast-charge timer and taper timer and a high-level signal disables this feature. Note that this applies to both AC and USB charging.

THERMAL SHUTDOWN AND PROTECTION

The bqTINY-II monitors the junction temperature, T_J , of the die and suspends charging if T_J exceeds $T_{(\text{SHTDWN})}$. Charging resumes when T_J falls below $T_{(\text{SHTDWN})}$ by approximately 15°C.

$\overline{\text{TE}}$ INPUT (TIMER ENABLED)

The $\overline{\text{TE}}$ digital input is used to disable or enable the fast-charge timer. A low-level signal on this pin enables the fast-charge timer and a high-level signal disables this feature.

Note that this applies to both AC and USB charging.

FUNCTIONAL DESCRIPTION

TIMER FAULT RECOVERY

As shown in Figure 4, bqTINY-II provides a recovery method to deal with timer fault conditions. The following summarizes this method:

Condition #1: Charge voltage above recharge threshold ($V_{(RCH)}$) and timeout fault occurs

Recovery method: bqTINY-II waits for the battery voltage to fall below the recharge threshold. This could happen as a result of a load on the battery, self-discharge or battery removal. Once the battery falls below the recharge threshold, the bqTINY-II clears the fault and starts a new charge cycle. A POR or \overline{CE} or \overline{TTE} toggle also clears the fault.

Condition #2: Charge voltage below recharge threshold ($V_{(RCH)}$) and timeout fault occurs

Recovery method: Under this scenario, the bqTINY-II applies the $I_{(FAULT)}$ current. This small current is used to detect a battery removal condition and remains on as long as the battery voltage stays below the recharge threshold. If the battery voltage goes above the recharge threshold, then the bqTINY-II disables the $I_{(FAULT)}$ current and executes the recovery method described for condition #1. Once the battery falls below the recharge threshold, the bqTINY-II clears the fault and starts a new charge cycle. A POR or \overline{CE} or \overline{TTE} toggle also clears the fault.

APPLICATION INFORMATION

THERMAL CONSIDERATIONS

The bqTINY-II is packaged in a thermally enhanced MLP package. The package includes a thermal pad to provide an effective thermal contact between the device and the printed circuit board (PCB). Full PCB design guidelines for this package are provided in the application note entitled, *QFN/SON PCB Attachment Application Note* (TI Literature No. SLUA271).

The most common measure of package thermal performance is thermal impedance (θ_{JA}) measured (or modeled) from the device junction to the air surrounding the package surface (ambient). The mathematical expression for θ_{JA} is:

$$\theta_{JA} = \frac{T_J - T_A}{P} \quad (5)$$

Where:

- T_J = device junction temperature
- T_A = ambient temperature
- P = device power dissipation

Factors that can greatly influence the measurement and calculation of θ_{JA} include:

- whether or not the device is board mounted
- trace size, composition, thickness, and geometry
- orientation of the device (horizontal or vertical)
- volume of the ambient air surrounding the device under test and airflow
- whether other surfaces are in close proximity to the device being tested

The device power dissipation, P , is a function of the charge rate and the voltage drop across the internal PowerFET. It can be calculated from the following equation:

$$P = (V_{IN} - V_{I(BAT)}) \times I_{O(OUT)} \quad (6)$$

Due to the charge profile of Li-xx batteries, the maximum power dissipation is typically seen at the beginning of the charge cycle when the battery voltage is at its lowest. See Figure 2.

PCB LAYOUT CONSIDERATIONS

It is important to pay special attention to the PCB layout. The following provides some guidelines:

- To obtain optimal performance, the decoupling capacitor from V_{CC} to V_{SS} and the output filter capacitors from OUT to V_{SS} should be placed as close as possible to the bqTINY, with short trace runs to both signal and V_{SS} pins.
- All low-current V_{SS} connections should be kept separate from the high-current charge or discharge paths from the battery. Use a single-point ground technique incorporating both the small signal ground path and the power ground path.
- The BAT pin is the voltage feedback to the device and should be connected with its trace as close to the battery pack as possible.
- The high current charge paths into IN and from the OUT pins must be sized appropriately for the maximum charge current in order to avoid voltage drops in these traces.
- The bqTINY-II is packaged in a thermally enhanced MLP package. The package includes a thermal pad to provide an effective thermal contact between the device and the printed circuit board (PCB). Full PCB design guidelines for this package are provided in the application note entitled: *QFN/SON PCB Attachment Application Note* (TI Literature No. SLUA271).

DRC (S-PDSO-N10)

CUSTOM DEVICE

PLASTIC SMALL OUTLINE

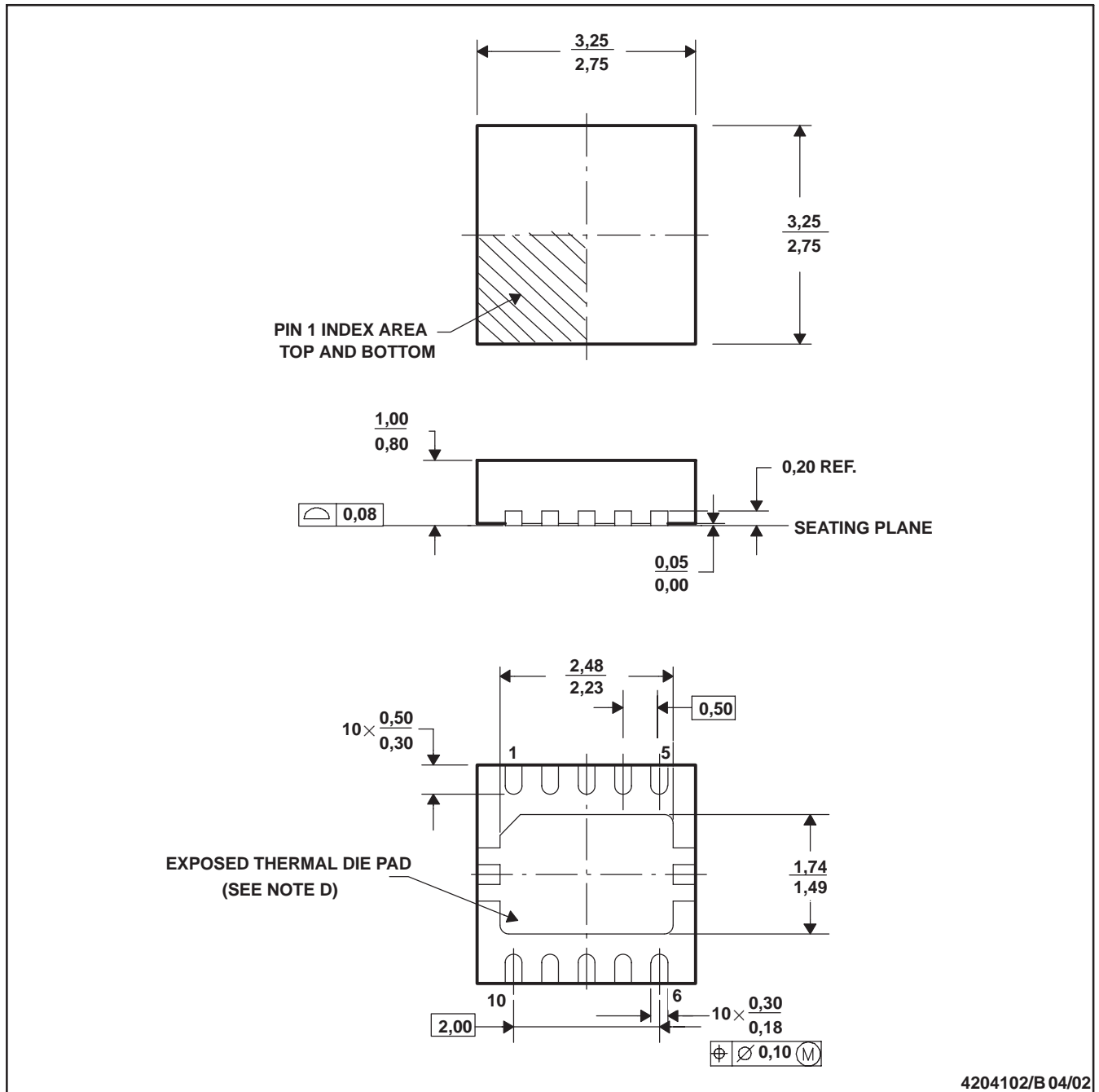

4204102/B 04/02

- NOTES: A. All linear dimensions are in millimeters.
 B. This drawing is subject to change without notice.
 C. Small Outline No-Lead (SON) package configuration.
 D. The package thermal performance may be enhanced by bonding the thermal die pad to an external thermal plane.

DRC (S-PDSO-N10) CUSTOM DEVICE PLASTIC SMALL OUTLINE

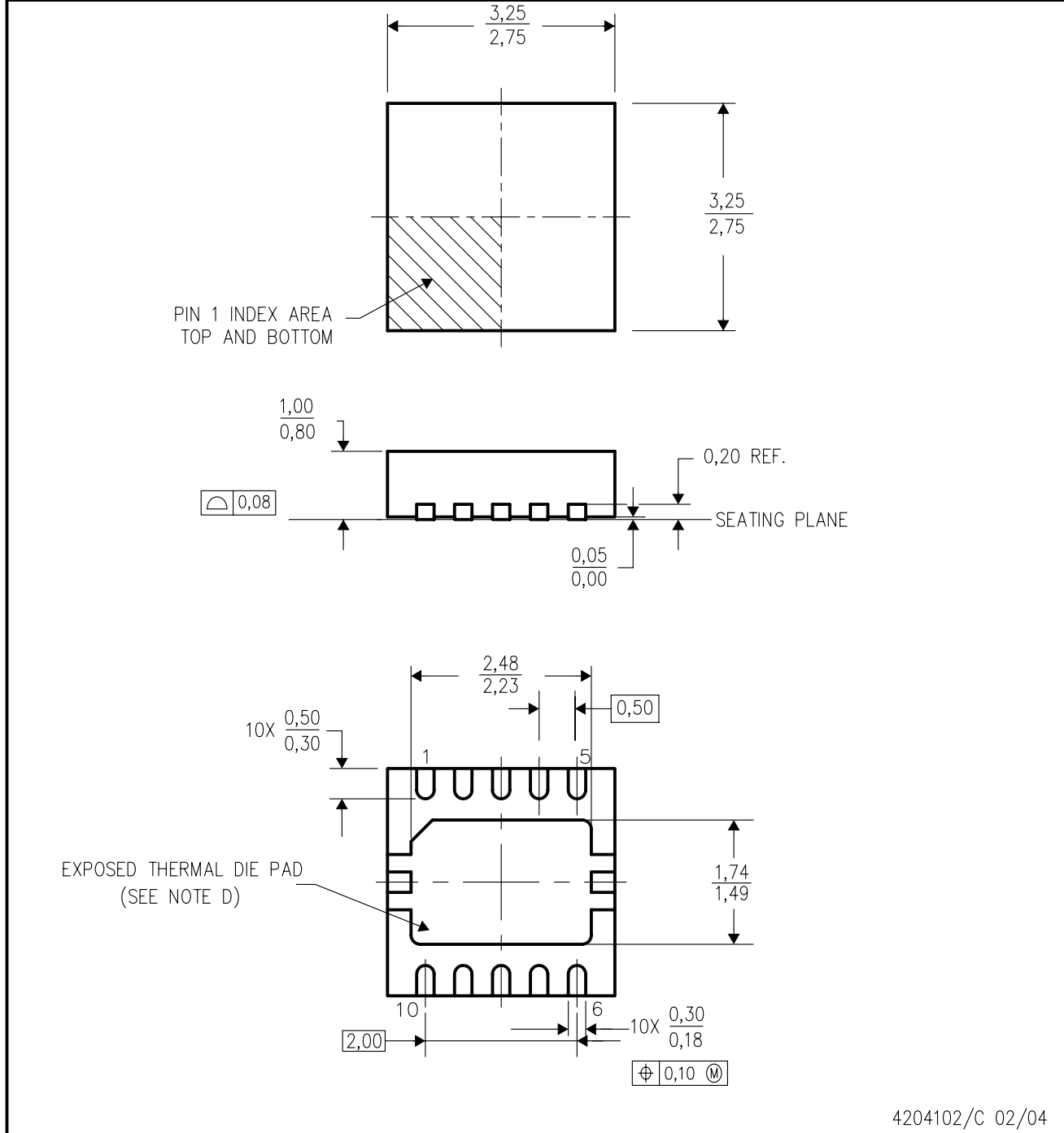

4204102/C 02/04

NOTES:

- A. All linear dimensions are in millimeters.
- B. This drawing is subject to change without notice.
- C. Small Outline No-Lead (SON) package configuration.
- D. The package thermal performance may be enhanced by bonding the thermal die pad to an external thermal plane.

IMPORTANT NOTICE

Texas Instruments Incorporated and its subsidiaries (TI) reserve the right to make corrections, modifications, enhancements, improvements, and other changes to its products and services at any time and to discontinue any product or service without notice. Customers should obtain the latest relevant information before placing orders and should verify that such information is current and complete. All products are sold subject to TI's terms and conditions of sale supplied at the time of order acknowledgment.

TI warrants performance of its hardware products to the specifications applicable at the time of sale in accordance with TI's standard warranty. Testing and other quality control techniques are used to the extent TI deems necessary to support this warranty. Except where mandated by government requirements, testing of all parameters of each product is not necessarily performed.

TI assumes no liability for applications assistance or customer product design. Customers are responsible for their products and applications using TI components. To minimize the risks associated with customer products and applications, customers should provide adequate design and operating safeguards.

TI does not warrant or represent that any license, either express or implied, is granted under any TI patent right, copyright, mask work right, or other TI intellectual property right relating to any combination, machine, or process in which TI products or services are used. Information published by TI regarding third-party products or services does not constitute a license from TI to use such products or services or a warranty or endorsement thereof. Use of such information may require a license from a third party under the patents or other intellectual property of the third party, or a license from TI under the patents or other intellectual property of TI.

Reproduction of information in TI data books or data sheets is permissible only if reproduction is without alteration and is accompanied by all associated warranties, conditions, limitations, and notices. Reproduction of this information with alteration is an unfair and deceptive business practice. TI is not responsible or liable for such altered documentation.

Resale of TI products or services with statements different from or beyond the parameters stated by TI for that product or service voids all express and any implied warranties for the associated TI product or service and is an unfair and deceptive business practice. TI is not responsible or liable for any such statements.

Following are URLs where you can obtain information on other Texas Instruments products and application solutions:

Products		Applications	
Amplifiers	amplifier.ti.com	Audio	www.ti.com/audio
Data Converters	dataconverter.ti.com	Automotive	www.ti.com/automotive
DSP	dsp.ti.com	Broadband	www.ti.com/broadband
Interface	interface.ti.com	Digital Control	www.ti.com/digitalcontrol
Logic	logic.ti.com	Military	www.ti.com/military
Power Mgmt	power.ti.com	Optical Networking	www.ti.com/opticalnetwork
Microcontrollers	microcontroller.ti.com	Security	www.ti.com/security
		Telephony	www.ti.com/telephony
		Video & Imaging	www.ti.com/video
		Wireless	www.ti.com/wireless

Mailing Address: Texas Instruments
Post Office Box 655303 Dallas, Texas 75265