

2.4GHz/5GHz、单频和双频、
802.11g/a RF收发器芯片

概述

MAX2825/MAX2826/MAX2827 单片 RF 收发器芯片，专为 802.11 WLAN 应用设计。MAX2825 设计用于单频 2.4GHz 802.11g (OFDM 和 CCK)，MAX2826 用于单频 5GHz 802.11a (OFDM)。MAX2827 为 802.11a+g 应用而设计。这些芯片包含了所有实现 RF 发射、接收功能的电路，提供完全集成的接收通路、发射通路、VCO、频率合成器以及基带/控制接口。为了实现完整的 RF 前端解决方案，仅需要加入 PA、RF 开关、RF 带通滤波器 (BPF)、RF 非平衡变压器及少量的无源器件。

每款芯片的接收器和发送器公用一路内部滤波器，省去了外部 SAW 滤波器。基带滤波和 Rx/Tx 信号通路完全满足 802.11a 和 802.11g 的 IEEE 标准。在要求的灵敏度下，每款器件均适合 802.11a/g OFDM 对应的全范围数据速率 (6Mbps、9Mbps、12Mbps、18Mbps、24Mbps、36Mbps、48Mbps 和 54Mbps) 以及 802.11g QPSK 数据速率 (1Mbps、2Mbps、5.5Mbps、11Mbps)。MAX2825/MAX2826/MAX2827 收发器采用小尺寸、56 引脚、裸露焊盘的薄型 QFN 封装。

应用

2.4GHz 802.11b/g 单频无线装置

5GHz 802.11a 单频无线装置

2.4GHz/5GHz 802.11a/b/g 双频无线装置

特性

◆ 单频/双频工作

MAX2825: 2.4GHz 到 2.5GHz

MAX2826: 5.15GHz 到 5.35GHz

MAX2827: 2.4GHz 到 2.5GHz 和 5.15GHz 到 5.35GHz

◆ 两种工作模式 (MAX2827)

802.11g (54Mbps 64-QAM OFDM 和 11Mbps CCK)

802.11a (54Mbps 64-QAM OFDM)

◆ 完整的 RF 收发器

在 54Mbps (802.11g) 时接收器灵敏度为 -75dBm
40dB Rx 边带抑制

-36dB 发射 EVM

在 100kHz 下具有 -98dBc/Hz 的本振相位噪声

可编程基带低通滤波器

具有 3 线串行接口的集成 PLL

94dB 接收增益控制范围

200ns Rx I/Q 直流建立时间

接收 RSSI 具有 60dB 动态范围

30dB 发射功率控制范围

Tx 和 Rx I/Q 误差检测

数字 Tx/Rx 模式和增益控制

◆ +2.7V 至 +3.6V 单电源供电

◆ 10μA 低功耗关断模式

◆ 小尺寸、56 引脚、TQFN 封装 (8mm x 8mm)

引脚配置

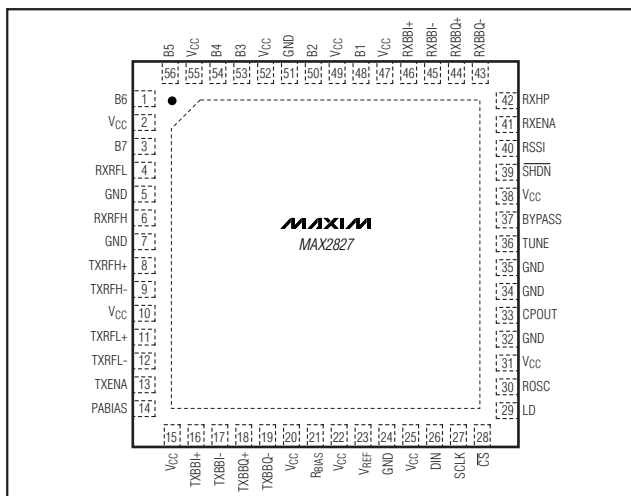

订购信息

PART	TEMP RANGE	PIN-PACKAGE
MAX2825ETN-TD	-40°C to +85°C	56 Thin QFN-EP*
MAX2826ETN-TD	-40°C to +85°C	56 Thin QFN-EP*
MAX2827ETN-TD	-40°C to +85°C	56 Thin QFN-EP*

*EP = 裸露焊盘。

2.4GHz/5GHz、单频和双频、 802.11g/a RF收发器芯片

ABSOLUTE MAXIMUM RATINGS

V_{CC}, TXRFH₋, TXRFL₋ to GND.....-0.3V to +4.2V
 RXRFH, RXRFL, TXBBI₋, TXBBQ₋, ROSC, RXBBI₋,
 RXBBQ₋, RSSI, PABIAS, V_{REF}, CPOUT, RXENA,
 TXENA, SHDN, CS, SCLK, DIN, B₋, RXHP, LD, RBIAS,
 BYPASS to GND.....-0.3V to (V_{CC} + 0.3V)
 RXBBI₋, RXBBQ₋, RSSI, PABIAS, V_{REF}, CPOUT, LD
 Short-Circuit Duration10s
 RF Input Power+10dBm

Continuous Power Dissipation (T_A = +70°C)
 56-Pin TQFN (derate 31.3mW/°C above +70°C)2500mW
 Operating Temperature Range-40°C to +85°C
 Junction Temperature+150°C
 Storage Temperature Range-65°C to +160°C
 Lead Temperature (soldering, 10s)+300°C

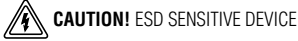

Stresses beyond those listed under "Absolute Maximum Ratings" may cause permanent damage to the device. These are stress ratings only, and functional operation of the device at these or any other conditions beyond those indicated in the operational sections of the specifications is not implied. Exposure to absolute maximum rating conditions for extended periods may affect device reliability.

DC ELECTRICAL CHARACTERISTICS

(MAX2825/MAX2826/MAX2827 Evaluation Kits: V_{CC} = 2.7V to 3.6V, Rx/Tx set to maximum gain, R_{BIAS} = 11kΩ, no signal at RF inputs, all RF inputs and outputs terminated into 50Ω, receiver baseband outputs are open, no signal applied to Tx I/Q BB inputs in Tx mode, f_{REFOSC} = 40MHz, registers set to default settings and corresponding test mode, T_A = -40°C to +85°C, unless otherwise noted. Typical values are at V_{CC} = +2.7V and T_A = +25°C, unless otherwise noted.) (Note 1)

PARAMETERS	CONDITIONS		MIN	TYP	MAX	UNITS
Supply Voltage			2.7		3.6	V
Supply Current	Shutdown mode, reference oscillator not applied, V _{IL} = 0V			10		μA
	Standby mode	802.11g MAX2825/MAX2827	T _A = +25°C	38	50	mA
			T _A = -40°C to +85°C		55	
		802.11a MAX2826/MAX2827	T _A = +25°C	48	64	
			T _A = -40°C to +85°C		74	
	Rx mode	802.11g MAX2825/MAX2827	T _A = +25°C	119	148	
			T _A = -40°C to +85°C		165	
		802.11a MAX2826/MAX2827	T _A = +25°C	148	180	
			T _A = -40°C to +85°C		199	
	Tx mode	802.11g MAX2825/MAX2827	T _A = +25°C	131	157	
			T _A = -40°C to +85°C		176	
		802.11a MAX2826/MAX2827	T _A = +25°C	151	191	
T _A = -40°C to +85°C				211		
Tx calibration mode	802.11g MAX2825/MAX2827		139			
	802.11a MAX2826/MAX2827		155			
Rx calibration mode	802.11g MAX2825/MAX2827		192			
	802.11a MAX2826/MAX2827		226			
Rx I/Q Output Common-Mode Voltage	T _A = +25°C		0.7	0.96	1.2	V
Rx I/Q Output Common-Mode-Voltage Variation	T _A = -40°C to +25°C			0.1		V
	T _A = +25°C to +85°C			-0.1		
Tx Baseband Input Common-Mode Voltage			0.9		1.3	V
Tx Baseband Input Bias Current				13		μA

2.4GHz/5GHz、单频和双频、 802.11g/a RF收发器芯片

MAX2825/MAX2826/MAX2827

DC ELECTRICAL CHARACTERISTICS (continued)

(MAX2825/MAX2826/MAX2827 Evaluation Kits: $V_{CC} = 2.7V$ to $3.6V$, Rx/Tx set to maximum gain, $R_{BIAS} = 11k\Omega$, no signal at RF inputs, all RF inputs and outputs terminated into 50Ω , receiver baseband outputs are open, no signal applied to Tx I/Q BB inputs in Tx mode, $f_{REFOSC} = 40MHz$, registers set to default settings and corresponding test mode, $T_A = -40^\circ C$ to $+85^\circ C$, unless otherwise noted. Typical values are at $V_{CC} = +2.7V$ and $T_A = +25^\circ C$, unless otherwise noted.) (Note 1)

PARAMETERS	CONDITIONS	MIN	TYP	MAX	UNITS
Reference Voltage Output	$-1mA < I_{OUT} < +1mA$		1.2		V
Digital Input-Voltage High, V_{IH}		$V_{CC} - 0.4$			V
Digital Input-Voltage Low, V_{IL}				0.4	V
Digital Input-Current High, I_{IH}		-1		+1	μA
Digital Input-Current Low, I_{IL}		-1		+1	μA
LD Output-Voltage High, V_{OH}	Sourcing $100\mu A$	$V_{CC} - 0.4$			V
LD Output-Voltage Low, V_{OL}	Sinking $100\mu A$			0.4	V

AC ELECTRICAL CHARACTERISTICS—802.11g Rx Mode (MAX2825/MAX2827)

(MAX2825/MAX2827 Evaluation Kits: $V_{CC} = 2.7V$, $f_{IN} = 2.437GHz$; receiver baseband I/Q outputs at $112mV_{RMS}$ ($-19dBV$), $f_{REFOSC} = 40MHz$, $SHDN = RXENA = CS = high$, $RXHP = TXENA = SCLK = DIN = low$, and $R_{BIAS} = 11k\Omega$, registers set to default settings and corresponding test mode, $T_A = +25^\circ C$, unless otherwise noted. Unmodulated single-tone RF input signal is used, unless otherwise indicated.) (Tables 1, 2, 3) (Note 1)

PARAMETER	CONDITIONS		MIN	TYP	MAX	UNITS
RECEIVER SECTION: LNA RF INPUT TO BASEBAND I/Q OUTPUTS						
RF Input Frequency Range			2.4		2.5	GHz
RF Input Return Loss	With 50Ω external match	LNA high-gain mode (B7:B6 = 11)		-16		dB
		LNA medium- and low-gain mode (B7:B6 = 10 or 0X)		-14		
Total Voltage Gain	Maximum gain, B7:B1 = 1111111	$T_A = +25^\circ C$	87	92		dB
		$T_A = -40^\circ C$ to $+85^\circ C$ (Note 1)	84			
Total Voltage Gain	Minimum gain, B7:B1 = 0000000	$T_A = +25^\circ C$		1	4.5	dB
RF Gain Steps (Note 2)	From high-gain mode (B7:B6 = 11) to medium-gain mode (B7:B6 = 10)			-16.5		dB
	From high-gain mode (B7:B6 = 11) to low-gain mode (B7:B6 = 0X)			-32		
Gain Variation Over RF Band	$f_{RF} = 2.4GHz$ to $2.5GHz$				3	dB
Baseband Gain Range	From maximum baseband gain (B5:B1 = 11111) to minimum baseband gain (B5:B1 = 00000)			62		dB
DSB Noise Figure	Voltage gain $\geq 85dB$ with B7:B6 = 11			3.5		dB
	Voltage gain = $65dB$ with B7:B6 = 11			3.5		
	Voltage gain = $50dB$ with B7:B6 = 11			4		
	Voltage gain = $45dB$ with B7:B6 = 10			16		
	Voltage gain = $15dB$ with B7:B6 = 0X			30		

2.4GHz/5GHz、单频和双频、 802.11g/a RF收发器芯片

AC ELECTRICAL CHARACTERISTICS—802.11g Rx Mode (MAX2825/MAX2827) (continued)

(MAX2825/MAX2827 Evaluation Kits: $V_{CC} = 2.7V$, $f_{IN} = 2.437GHz$; receiver baseband I/Q outputs at $112mV_{RMS}$ (-19dBV), $f_{REFOSC} = 40MHz$, $\overline{SHDN} = \overline{RXENA} = \overline{CS} = \text{high}$, $RXHP = \overline{TXENA} = \overline{SCLK} = \overline{DIN} = \text{low}$, and $R_{BIAS} = 11k\Omega$, registers set to default settings and corresponding test mode, $T_A = +25^\circ C$, unless otherwise noted. Unmodulated single-tone RF input signal is used, unless otherwise indicated.) (Tables 1, 2, 3) (Note 1)

PARAMETER	CONDITIONS		MIN	TYP	MAX	UNITS
Output P-1dB	Voltage gain = 90dB with B7:B6 = 11			3		V_{P-P}
Out-of-Band Input IP3	-35dBm jammers at 40MHz and 78MHz offset; based on IM3 at 2MHz	Voltage gain = 60dB, with B7:B6 = 11		-10.5		dBm
		Voltage gain = 45dB, with B7:B6 = 10		-1		
		Voltage gain = 40dB, with B7:B6 = 0X		21		
In-Band Input P-1dB	Voltage gain = 40dB, with B7:B6 = 11			-30		dBm
	Voltage gain = 25dB, with B7:B6 = 10			-16		
	Voltage gain = 5dB, with B7:B6 = 0X			1		
In-Band Input IP3	Tones at 7MHz and 8MHz, IM3 at 6MHz and 9MHz, $P_{IN} = -40Bm$ per tone	Voltage gain = 40dB, with B7:B6 = 11		-17		dBm
		Voltage gain = 25dB, with B7:B6 = 10		-5		
		Voltage gain = 5dB, with B7:B6 = 0X		14		
I/Q Phase Error	B7:B1 = 1101110, 1σ variation			± 0.4		degrees
I/Q Gain Imbalance	B7:B1 = 1101110, 1σ variation			± 0.1		dB
Tx to Rx Conversion Gain for I/Q Calibration	(Note 4)			0		dB
I/Q Static DC Offset	RXHP = 1, 1σ variation			± 2		mV
I/Q DC Droop	After switching RXHP to 0, D2 = 0 (see the <i>RX Control/RSSI Register</i>)			1		mV/ms
RF Gain-Change Settling Time	Gain change from high gain to medium gain, high gain to low gain, or medium gain to low gain; gain settling to within $\pm 2dB$ of steady state			0.4		μs
Baseband VGA Settling Time	Gain change from B5:B1 = 10111 to B5:B1 = 00111; gain settling to within $\pm 2dB$ of steady state			0.1		μs
Rx I/Q Output Load Impedance (Note 3)	Differential resistance		10			k Ω
	Differential capacitance				8	pF
Spurious Signal Emissions at LNA Input	RF = 1GHz to 26.5GHz			-65		dBm
RECEIVER BASEBAND FILTERS						
Baseband -3dB Corner Frequency	(See the <i>Lowpass-Filter Register</i>)	Nominal mode		9.5		MHz
		Turbo mode 1		14		
		Turbo mode 2		18		

2.4GHz/5GHz、单频和双频、 802.11g/a RF收发器芯片

MAX2825/MAX2826/MAX2827

AC ELECTRICAL CHARACTERISTICS—802.11g Rx Mode (MAX2825/MAX2827) (continued)

(MAX2825/MAX2827 Evaluation Kits: $V_{CC} = 2.7V$, $f_{IN} = 2.437GHz$; receiver baseband I/Q outputs at $112mV_{RMS}$ (-19dBV), $f_{REFOSC} = 40MHz$, $\overline{SHDN} = RXENA = \overline{CS} = high$, $RXHP = TXENA = SCLK = DIN = low$, and $R_{BIAS} = 11k\Omega$, registers set to default settings and corresponding test mode, $T_A = +25^\circ C$, unless otherwise noted. Unmodulated single-tone RF input signal is used, unless otherwise indicated.) (Tables 1, 2, 3) (Note 1)

PARAMETER	CONDITIONS		MIN	TYP	MAX	UNITS
Baseband Filter Rejection (Nominal Mode)	$f_{Baseband} = 15MHz$		20			dB
	$f_{Baseband} = 20MHz$		39			
	$f_{Baseband} > 40MHz$		86			
RSSI						
RSSI Minimum Output Voltage	RXHP = 1, low range (D11 = 0, see the <i>Rx Control/RSSI Register</i>)		0.5			V
	RXHP = 1, high range (D11 = 1, see the <i>Rx Control/RSSI Register</i>)		0.52			
RSSI Maximum Output Voltage	RXHP = 1, low range (D11 = 0, see the <i>Rx Control/RSSI Register</i>)		2			V
	RXHP = 1, high range (D11 = 1, see the <i>Rx Control/RSSI Register</i>)		2.5			
RSSI Slope	RXHP = 1, low range (D11 = 0, see the <i>Rx Control/RSSI Register</i>)		22			mV/dB
	RXHP = 1, high range (D11 = 1, see the <i>Rx Control/RSSI Register</i>)		30			
RSSI Output Settling Time	To within 3dB of steady state	+40dB signal step	0.2		μs	
		-40dB signal step	0.7			

AC ELECTRICAL CHARACTERISTICS—802.11a RX Mode (MAX2826/MAX2827)

(MAX2826/MAX2827 Evaluation Kits: $V_{CC} = 2.7V$, $f_{IN} = 5.25GHz$; receiver baseband I/Q outputs at $112mV_{RMS}$ (-19dBV), $f_{REFOSC} = 40MHz$, $\overline{SHDN} = RXENA = \overline{CS} = high$, $RXHP = TXENA = SCLK = DIN = low$, and $R_{BIAS} = 11k\Omega$, registers set to default settings and corresponding test mode, $T_A = +25^\circ C$, unless otherwise noted. Unmodulated single-tone RF input signal is used, unless otherwise indicated.) (Tables 1, 2, 3) (Note 1)

PARAMETER	CONDITIONS		MIN	TYP	MAX	UNITS
RECEIVER SECTION: LNA RF INPUT TO BASEBAND I/Q OUTPUTS						
RF Input Frequency Range			5.15		5.35	GHz
RF Input Return Loss	With 50Ω external match	LNA high-gain mode (B7:B6 = 11)	-20		dB	
		LNA medium- and low-gain mode (B7:B6 = 10 or 0X)	-10			
Total Voltage Gain	Maximum gain, B7:B1 = 11111111	$T_A = +25^\circ C$	86	91.5	dB	
		$T_A = -40^\circ C$ to $+85^\circ C$ (Note 1)	83			
	Minimum gain, B7:B1 = 00000000	$T_A = +25^\circ C$	3.5	6		

2.4GHz/5GHz、单频和双频、 802.11g/a RF收发器芯片

AC ELECTRICAL CHARACTERISTICS—802.11a RX Mode (MAX2826/MAX2827) (continued)

(MAX2826/MAX2827 Evaluation Kits: $V_{CC} = 2.7V$, $f_{IN} = 5.25GHz$; receiver baseband I/Q outputs at $112mV_{RMS}$ (-19dBV), $f_{REFOSC} = 40MHz$, $\overline{SHDN} = RXENA = \overline{CS} = high$, $RXHP = TXENA = SCLK = DIN = low$, and $R_{BIAS} = 11k\Omega$, registers set to default settings and corresponding test mode, $T_A = +25^\circ C$, unless otherwise noted. Unmodulated single-tone RF input signal is used, unless otherwise indicated.) (Tables 1, 2, 3) (Note 1)

PARAMETER	CONDITIONS		MIN	TYP	MAX	UNITS
RF Gain Steps (Note 2)	From high-gain mode (B7:B6 = 11) to medium-gain mode (B7:B6 = 10)			-17		dB
	From high-gain mode (B7:B6 = 11) to low-gain mode (B7:B6 = 0X)			-28		
Gain Variation Over RF Band	$f_{RF} = 5.15GHz$ to $5.35GHz$				4	dB
Baseband Gain Range	From maximum baseband gain (B5:B1 = 11111) to minimum baseband gain (B5:B1 = 00000)			62		dB
DSB Noise Figure	Voltage gain $\geq 85dB$ with B7:B6 = 11			4.5		dB
	Voltage gain = 65dB with B7:B6 = 11			4.6		
	Voltage gain = 50dB with B7:B6 = 11			5		
	Voltage gain = 45dB with B7:B6 = 10			6		
	Voltage gain = 15dB with B7:B6 = 0X			27		
Output P-1dB	Voltage gain = 90dB with B7:B6 = 11			3		V _{P-P}
Out-of-Band Input IP3	-35dBm jammers at 40MHz and 78MHz offset; based on IM3 at 2MHz	Voltage gain = 60dB, with B7:B6 = 11		-10		dBm
		Voltage gain = 45dB, with B7:B6 = 10		2		
		Voltage gain = 40dB, with B7:B6 = 0X		18		
In-Band Input P-1dB	Voltage gain = 35dB, with B7:B6 = 11			-30		dBm
	Voltage gain = 20dB, with B7:B6 = 10			-12		
	Voltage gain = 5dB, with B7:B6 = 0X			-1		
In-Band Input IP3	Tones at 7MHz and 8MHz, IM3 at 6MHz and 9MHz, $P_{IN} = -40Bm$ per tone	Voltage gain = 35dB, with B7:B6 = 11		-16		dBm
		Voltage gain = 20dB, with B7:B6 = 10		-0.5		
		Voltage gain = 5dB, with B7:B6 = 0X		12		
I/Q Phase Error	B7:B1 = 1101110, 1σ variation			± 0.2		degrees
I/Q Gain Imbalance	B7:B1 = 1101110, 1σ variation			± 0.1		dB
Tx to Rx Conversion Gain for I/Q Calibration	(Note 4)			2		dB
I/Q Static DC Offset	RXHP = 1, 1σ variation			± 2		mV
I/Q DC Droop	After switching RXHP to 0, D2 = 0 (see the <i>Rx Control/RSSI Register</i>)			1		mV/ms

2.4GHz/5GHz、单频和双频、 802.11g/a RF收发器芯片

MAX2825/MAX2826/MAX2827

AC ELECTRICAL CHARACTERISTICS—802.11a RX Mode (MAX2826/MAX2827) (continued)

(MAX2826/MAX2827 Evaluation Kits: $V_{CC} = 2.7V$, $f_{IN} = 5.25GHz$; receiver baseband I/Q outputs at $112mV_{RMS}$ (-19dBV), $f_{REFOSC} = 40MHz$, $\overline{SHDN} = \overline{RXENA} = \overline{CS} = \text{high}$, $RXHP = \overline{TXENA} = \overline{SCLK} = \overline{DIN} = \text{low}$, and $R_{BIAS} = 11k\Omega$, registers set to default settings and corresponding test mode, $T_A = +25^\circ C$, unless otherwise noted. Unmodulated single-tone RF input signal is used, unless otherwise indicated.) (Tables 1, 2, 3) (Note 1)

PARAMETER	CONDITIONS	MIN	TYP	MAX	UNITS
RF Gain-Change Settling Time	Gain change from high gain to medium gain, high gain to low gain, or medium gain to low gain; gain settling to within $\pm 2dB$ of steady state		0.4		μs
Baseband VGA Settling Time	Gain change from B5:B1 = 10111 to B5:B1 = 00111; gain settling to within $\pm 2dB$ of steady state		0.1		μs
Rx I/Q Output Load Impedance (Note 3)	Differential resistance	10			k Ω
	Differential capacitance			8	pF
Spurious Signal Emissions at LNA Input	RF = 1GHz to 26.5GHz		-50		dBm
RECEIVER BASEBAND FILTERS					
Baseband -3dB Corner Frequency	(See the <i>Lowpass Filter Register</i>)	Nominal mode		9.5	MHz
		Turbo mode 1		14	
		Turbo mode 2		18	
Baseband Filter Rejection (Nominal Mode)	$f_{Baseband} = 15MHz$		20		dB
	$f_{Baseband} = 20MHz$		39		
	$f_{Baseband} > 40MHz$		86		
RSSI					
RSSI Minimum Output Voltage	RXHP = 1, low range (D11 = 0, see the <i>Rx Control/RSSI Register</i>)		0.5		V
	RXHP = 1, high range (D11 = 1, see the <i>Rx Control/RSSI Register</i>)		0.52		
RSSI Maximum Output Voltage	RXHP = 1, low range (D11 = 0, see the <i>Rx Control/RSSI Register</i>)		2		V
	RXHP = 1, high range (D11 = 1, see the <i>Rx Control/RSSI Register</i>)		2.5		
RSSI Slope	RXHP = 1, low range (D11 = 0, see the <i>Rx Control/RSSI Register</i>)		22		mV/dB
	RXHP = 1, high range (D11 = 1, see the <i>Rx Control/RSSI Register</i>)		30		
RSSI Output Settling Time	To within 3dB of steady state	+40dB signal step		0.2	μs
		-40dB signal step		0.7	

2.4GHz/5GHz、单频和双频、 802.11g/a RF收发器芯片

AC ELECTRICAL CHARACTERISTICS—802.11g Tx Mode (MAX2825/MAX2827)

(MAX2825/MAX2827 Evaluation Kits: $V_{CC} = 2.7V$, $f_{OUT} = 2.437GHz$, $f_{REFOSC} = 40MHz$, $\overline{SHDN} = TXENA = \overline{CS} = high$, $RXENA = SCLK = DIN = low$, and $R_{BIAS} = 11k\Omega$, 100mV_{RMS} sine and cosine signal (or 100mV_{RMS}, 54Mbps IEEE 802.11g I/Q signals wherever OFDM is mentioned) applied to baseband I/Q inputs of transmitter, registers set to default settings and corresponding test mode, $T_A = +25^\circ C$, unless otherwise noted.) (Tables 4 and 7) (Note 1)

PARAMETER	CONDITIONS		MIN	TYP	MAX	UNITS
TRANSMIT SECTION: Tx BASEBAND I/Q INPUTS TO RF OUTPUTS						
RF Output Frequency Range, f_{RF}			2.4		2.5	GHz
Output Power	54Mbps 802.11g OFDM signal	1.5% EVM		-2.5		dBm
		B6:B1 = 111011		-4.5		
Output Power (CW)	$V_{IN} = 100mV_{RMS}$ at 1MHz I/Q CW signal, B6:B1 = 111111			-0.7		dBm
Output Power Range	B6:B1 = 111111 to B6:B1 = 000000			30		dB
Carrier Leakage	Without DC offset cancellation			-29		dBc
Unwanted Sideband Suppression	Uncalibrated			46		dB
Tx Output ACP	Measured with 1MHz resolution bandwidth at 22MHz offset from channel center (B6:B1 = 111011)			-69		dBm/MHz
RF Output Return Loss	With external 50 Ω match			10		dB
RF Spurious Signal Emissions	B6:B1 = 111011	$4/7 \times f_{RF}$		-61		dBm
		$10/7 \times f_{RF}$		-49		
		$13/7 \times f_{RF}$		-43		
		$22/7 \times f_{RF}$		-60		
Baseband -3dB Corner Frequency	(See the <i>Lowpass Filter Register</i>)	Nominal mode		12		MHz
		Turbo mode 1		18		
		Turbo mode 2		24		
Baseband Filter Rejection	At 30MHz, in nominal mode (see the <i>Lowpass Filter Register</i>)			63		dB
Tx Baseband Input Impedance	Differential resistance			60		k Ω
	Differential capacitance			0.5		pF
TRANSMITTER LO LEAKAGE AND I/Q CALIBRATION USING LO LEAKAGE AND SIDEBAND DETECTOR (SEE THE Tx/Rx Calibration Mode SECTION)						
Tx BASEBAND I/Q INPUTS TO RECEIVER OUTPUTS						
LO Leakage and Sideband-Detector Output	Calibration register, D12:D11 = 11, A3:A0 = 0110	Output at $1 \times f_{TONE}$ (for LO leakage = -29dBc), $f_{TONE} = 2MHz$, 100mV _{RMS}		-17		dBV _{RMS}
		Output at $2 \times f_{TONE}$ (for sideband suppression = -46dBc), $f_{TONE} = 2MHz$, 100mV _{RMS}		-23		
Amplifier Gain Range	D12:D11 = 00 to D12:D11 = 11, A3:A0 = 0110			27		dB
Lower -3dB Corner Frequency				1.7		MHz

2.4GHz/5GHz、单频和双频、 802.11g/a RF收发器芯片

MAX2825/MAX2826/MAX2827

AC ELECTRICAL CHARACTERISTICS—802.11a Tx Mode (MAX2826/MAX2827)

(MAX2826/MAX2827 Evaluation Kits: $V_{CC} = 2.7V$, $f_{OUT} = 5.25GHz$, $f_{REFOSC} = 40MHz$, $\overline{SHDN} = TXENA = \overline{CS} = high$, $RXENA = SCLK = DIN = low$, $R_{BIAS} = 11k\Omega$, $100mV_{RMS}$ sine and cosine signal (or $100mV_{RMS}$, 54Mbps IEEE 802.11a I/Q signals wherever OFDM is mentioned) applied to baseband I/Q inputs of transmitter, registers set to default settings and corresponding test mode, $T_A = +25^\circ C$, unless otherwise noted.) (Tables 4 and 7) (Note 1)

PARAMETER	CONDITIONS		MIN	TYP	MAX	UNITS
TRANSMIT SECTION: Tx BASEBAND I/Q INPUTS TO RF OUTPUTS						
RF Output Frequency Range, f_{RF}			5.15		5.35	GHz
Output Power	54Mbps 802.11a OFDM signal	2% EVM		-5.5		dBm
		B6:B1 = 111100		-7		
Output Power (CW)	$V_{IN} = 100mV_{RMS}$ at 1MHz I/Q CW signal, B6:B1 = 111111			-4		dBm
Output Power Range	B6:B1 = 111111 to B6:B1 = 000000			30		dB
Carrier Leakage	Without DC offset cancellation			-29		dBc
Unwanted Sideband Suppression	Uncalibrated			49		dB
Tx Output ACP	Measured with 1MHz resolution bandwidth at 30MHz offset from channel center (B6:B1 = 111100)			-80		dBm/MHz
RF Output Return Loss	With external 50Ω match			11		dB
RF Spurious Signal Emissions	B6:B1 = 111100	$4/5 \times f_{RF}$		-55		dBm
		$6/5 \times f_{RF}$		-56		
		$7/5 \times f_{RF}$		-50		
		$8/5 \times f_{RF}$		-48		
Baseband -3dB Corner Frequency	(See the <i>Lowpass Filter Register</i>)	Nominal mode		12		MHz
		Turbo mode 1		18		
		Turbo mode 2		24		
Baseband Filter Rejection	At 30MHz, in nominal mode (see the <i>Lowpass Filter Register</i>)			63		dB
Tx Baseband Input Impedance	Differential resistance			60		$k\Omega$
	Differential capacitance			0.5		pF
TRANSMITTER LO LEAKAGE AND I/Q CALIBRATION USING LO LEAKAGE AND SIDEBAND DETECTOR (SEE THE Tx/Rx Calibration Mode SECTION)						
Tx BASEBAND I/Q INPUTS TO RECEIVER OUTPUTS						
LO Leakage and Sideband-Detector Output	Calibration register, D12:D11 = 1, A3:A0 = 01101	Output at $1 \times f_{TONE}$ (for LO leakage = -29dBc), $f_{TONE} = 2MHz$, $100mV_{RMS}$		-27		dBV _{RMS}
		Output at $2 \times f_{TONE}$ (for sideband suppression = -49dBc), $f_{TONE} = 2MHz$, $100mV_{RMS}$		-33		
Amplifier Gain Range	D12:D11 = 00 to D12:D11 = 11, A3:A0 = 0110			27		dB
Lower -3dB Corner Frequency				1.7		MHz

2.4GHz/5GHz、单频和双频、 802.11g/a RF收发器芯片

AC ELECTRICAL CHARACTERISTICS—Frequency Synthesis

(MAX2825/MAX2826/MAX2827 Evaluation Kits: $V_{CC} = 2.7V$, $f_{RF} = 2.437GHz$ (802.11g) or $f_{RF} = 5.25GHz$ (802.11a), $f_{REFOSC} = 40MHz$, $\overline{SHDN} = \overline{CS} = \text{high}$, $SCLK = \overline{DIN} = \text{low}$, PLL loop bandwidth = 140kHz, and $R_{BIAS} = 11k\Omega$, $T_A = +25^\circ C$, unless otherwise noted.) (Note 1)

PARAMETER	CONDITIONS		MIN	TYP	MAX	UNITS
FREQUENCY SYNTHESIZER						
RF Channel Center Frequency	802.11g mode		2400		2500	MHz
	802.11a mode		5150		5350	
Charge-Pump Comparison Frequency				20		MHz
f_{REFOSC} Input Frequency			20		44	MHz
Reference-Divider Ratio			1		4	
f_{REFOSC} Input Levels	AC-coupled		800			mVp-p
f_{REFOSC} Input Impedance				10		k Ω
Closed-Loop Phase Noise	802.11g	$f_{OFFSET} = 1kHz$		-87		dBc/Hz
		$f_{OFFSET} = 10kHz$		-100		
		$f_{OFFSET} = 100kHz$		-99		
		$f_{OFFSET} = 1MHz$		-111		
		$f_{OFFSET} = 10MHz$		-123		
	802.11a	$f_{OFFSET} = 1kHz$		-81		
		$f_{OFFSET} = 10kHz$		-94		
		$f_{OFFSET} = 100kHz$		-94		
		$f_{OFFSET} = 1MHz$		-107		
		$f_{OFFSET} = 10MHz$		-120		
Closed-Loop Integrated Phase Noise	RMS phase jitter, integrate from 10kHz to 10MHz offset		802.11g		0.6	degrees
			802.11a		1	
Charge-Pump Output Current				4		mA
Charge-Pump Output Voltage	>80% of I_{CP}		0.5		$V_{CC} - 0.5V$	V
Reference Spurs	20MHz offset		802.11g		-52	dBc
			802.11a		-44	
VOLTAGE-CONTROLLED OSCILLATOR						
VCO Tuning Voltage Range			0.5		2.2	V
LO Tuning Gain	802.11g	$V_{TUNE} = 0.5V$		128		MHz/V
		$V_{TUNE} = 2.2V$		72		
	802.11a	$V_{TUNE} = 0.5V$		247		
		$V_{TUNE} = 2.2V$		132		
VCO Tune Input Leakage Current				1		μA

2.4GHz/5GHz、单频和双频、 802.11g/a RF收发器芯片

MAX2825/MAX2826/MAX2827

AC ELECTRICAL CHARACTERISTICS—Miscellaneous Blocks

(MAX2825/MAX2826/MAX2827 Evaluation Kits: $V_{CC} = 2.7V$, $f_{RF} = 2.437GHz$ (802.11g) or $f_{RF} = 5.25GHz$ (802.11a), $f_{REFOSC} = 40MHz$, $\overline{SHDN} = \overline{CS} = \text{high}$, $SCLK = DIN = \text{low}$, and $R_{BIAS} = 11k\Omega$, $T_A = +25^\circ C$, unless otherwise noted.) (Note 1)

PARAMETER	CONDITIONS		MIN	TYP	MAX	UNITS
PA BIAS						
Number of Programmable Bits				6		Bits
Minimum Output Sink Current	D5:D0 = 000000 (see the <i>PA Bias Register</i>)			0		μA
Maximum Output Sink Current	D5:D0 = 111111 (see the <i>PA Bias Register</i>)			311		μA
Output Compliance Voltage				0.8		V
Turn-On Time	D9:D6 = 0000 (see the <i>PA Bias Register</i>)			0.2		μs
DNL				1		LSB
ON-CHIP TEMPERATURE SENSOR						
Output Voltage	D11 = 1 (see the <i>Rx Control/RSSI Register</i>)	$T_A = -40^\circ C$		0.5		V
		$T_A = +85^\circ C$		1.6		

AC ELECTRICAL CHARACTERISTICS—Timing

(MAX2825/MAX2826/MAX2827 Evaluation Kits: $V_{CC} = 2.7V$, $f_{RF} = 2.437GHz$ (802.11g) or $f_{RF} = 5.25GHz$ (802.11a), $f_{REFOSC} = 40MHz$, $\overline{SHDN} = \overline{CS} = \text{high}$, $SCLK = DIN = \text{low}$, PLL loop bandwidth = 140kHz, and $R_{BIAS} = 11k\Omega$, $T_A = +25^\circ C$, unless otherwise noted.) (Note 1)

PARAMETER	CONDITIONS		MIN	TYP	MAX	UNITS
SYSTEM TIMING (SEE FIGURE 1)						
Turn-On Time	From \overline{SHDN} rising edge (PLL locked)			50		μs
Shutdown Time				2		μs
Channel Switching Time	2.4GHz to 2.5GHz			25		μs
	5.15GHz to 5.35GHz			35		
Rx/Tx Turnaround Time	Measured from Tx- or Rx-enable rising edge; signal settling to within $\pm 2dB$ of steady state	Rx to Tx		1		μs
		Tx to Rx, $RXHP = 1$		1.2		
Tx Turn-On Time (from Standby Mode)	From Tx-enable rising edge; signal settling to within $\pm 2dB$ of steady state			1		μs
Rx Turn-On Time (from Standby Mode)	From Rx-enable rising edge; signal settling to within $\pm 2dB$ of steady state			1.2		μs
3-WIRE SERIAL INTERFACE TIMING (SEE FIGURE 2)						
SCLK Rising Edge to \overline{CS} Falling-Edge Wait Time, t_{CSO}				6		ns
Falling Edge of \overline{CS} to Rising Edge of First SCLK Time, t_{CSS}				6		ns
DIN to SCLK Setup Time, t_{DS}				6		ns
DIN to SCLK Hold Time, t_{DH}				6		ns
SCLK Pulse-Width High, t_{CH}				6		ns
SCLK Pulse-Width Low, t_{CL}				6		ns

2.4GHz/5GHz、单频和双频、 802.11g/a RF收发器芯片

AC ELECTRICAL CHARACTERISTICS—Timing (continued)

(MAX2825/MAX2826/MAX2827 Evaluation Kits: $V_{CC} = 2.7V$, $f_{RF} = 2.437GHz$ (802.11g) or $f_{RF} = 5.25GHz$ (802.11a), $f_{REFOSC} = 40MHz$, $\overline{SHDN} = \overline{CS} = \text{high}$, $SCLK = DIN = \text{low}$, PLL loop bandwidth = 140kHz, and $R_{BIAS} = 11k\Omega$, $T_A = +25^\circ C$, unless otherwise noted.) (Note 1)

PARAMETER	CONDITIONS	MIN	TYP	MAX	UNITS
Last Rising Edge of SCLK to Rising Edge of \overline{CS} or Clock to Load Enable Setup Time, t_{CSH}			6		ns
\overline{CS} High Pulse Width, t_{CSW}			20		ns
Time Between the Rising Edge of \overline{CS} and the Next Rising Edge of SCLK, t_{CS1}			6		ns
Clock Frequency, f_{CLK}			80		MHz
Rise Time, t_R			2		ns
Fall Time, t_F			2		ns

Note 1: Devices are production tested at +85°C only. Min and max limits at temperatures other than +85°C are guaranteed by design and characterization.

Note 2: The expected part-to-part variation of the RF gain step is $\pm 1dB$.

Note 3: Guaranteed by design and characterization.

Note 4: Tx I/Q inputs = 100mV_{RMS}. Set Tx VGA gain to max and RX VGA gain to xx10100 (802.11g) or xx01110 (802.11a), through SPI.

2.4GHz/5GHz、单频和双频、 802.11g/a RF收发器芯片

表 1. 接收器前端增益控制设置

B7	B6	GAIN
1	1	High
1	0	Medium
0	X	Low

表 2. 接收器基带 VGA 增益设置

B5:B1	GAIN (dB)
11111	Max
11110	Max - 2dB
11101	Max - 4dB
:	:
00000	Min

表 3. 接收器基带 VGA 增益级差设置

BIT	GAIN STEP (typ) (dB)
B1	2
B2	4
B3	8
B4	16
B5	32

表 4. Tx VGA 增益控制设置

NUMBER	B6:B1	OUTPUT SIGNAL POWER
63	111111	Max
62	111110	Max - 0.5dB
61	111101	Max - 1.0dB
:	:	:
49	110001	Max - 7dB
48	110000	Max - 7.5dB
47	101111	Max - 8dB
46	101110	Max - 8dB
45	101101	Max - 9dB
44	101100	Max - 9dB
:	:	:
5	000101	Max - 29dB
4	000100	Max - 29dB
3	000011	Max - 30dB
2	000010	Max - 30dB
1	000001	Max - 30dB
0	000000	Max - 30dB

MAX2825/MAX2826/MAX2827

2.4GHz/5GHz、单频和双频、802.11g/a RF收发器芯片

典型工作特性

($V_{CC} = 2.7V$, $f_{RF} = 2.437GHz$ (802.11g) or $f_{RF} = 5.25GHz$ (802.11a), $f_{REFOSC} = 40MHz$, $\overline{SHDN} = \overline{CS} = high$, $RXHP = SCLK = DIN = low$, $R_{BIAS} = 11k\Omega$, $T_A = +25^\circ C$, using the MAX2825/MAX2826/MAX2827 Evaluation Kits.)

802.11g

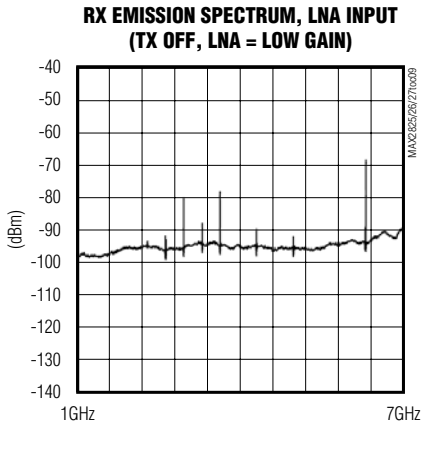
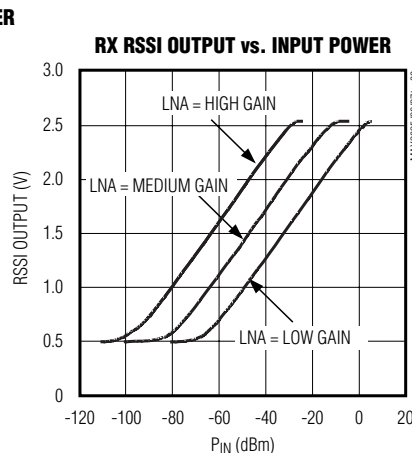
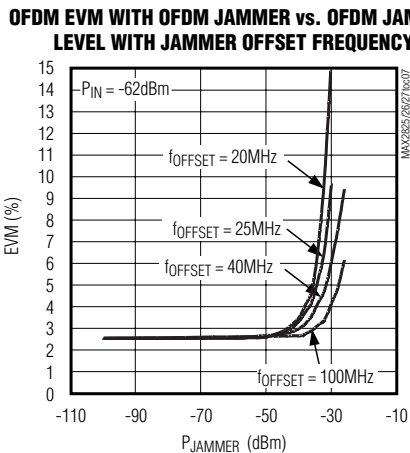
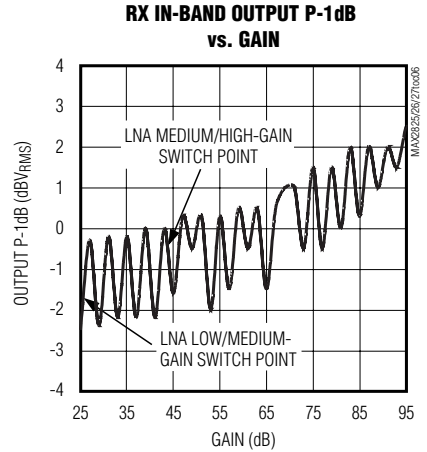
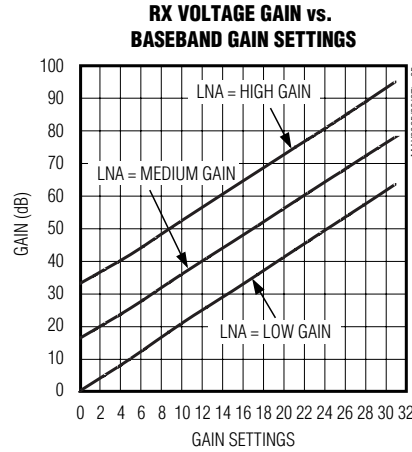
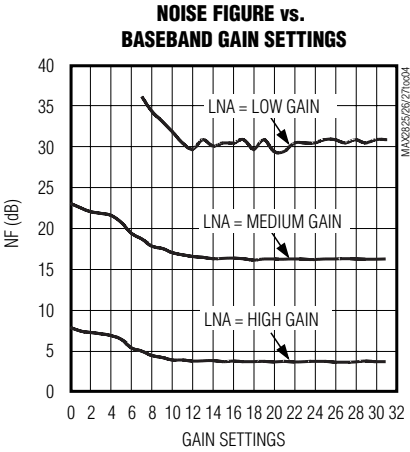
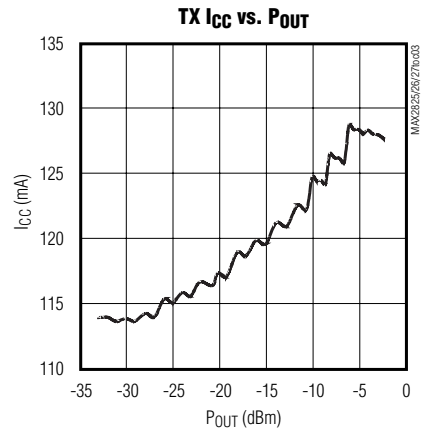
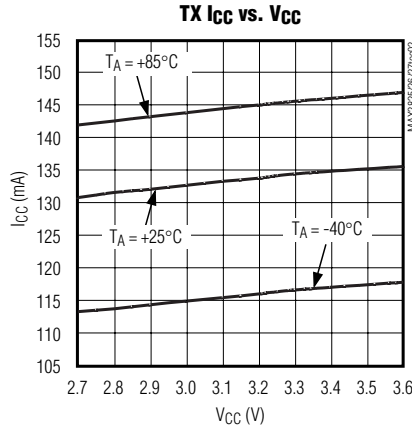
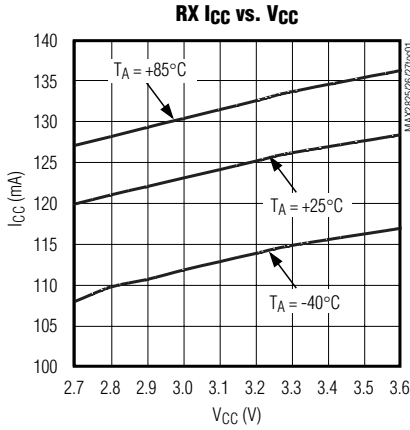

2.4GHz/5GHz、单频和双频、 802.11g/a RF收发器芯片

典型工作特性 (续)

($V_{CC} = 2.7V$, $f_{RF} = 2.437GHz$ (802.11g) or $f_{RF} = 5.25GHz$ (802.11a), $f_{REFOSC} = 40MHz$, $\overline{SHDN} = \overline{CS} = high$, $RXHP = SCLK = DIN = low$, $RBIAS = 11k\Omega$, $T_A = +25^\circ C$, using the MAX2825/MAX2826/MAX2827 Evaluation Kits.)

802.11g

**RX I/Q DC OFFSET SETTLING RESPONSE
(-8dB BB VGA GAIN STEP)**

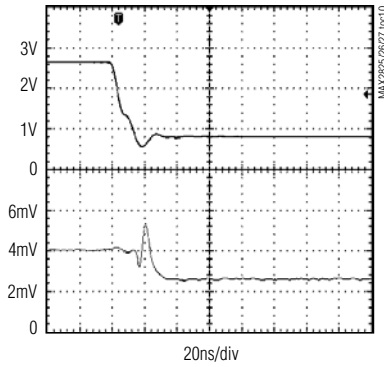

**RX I/Q DC OFFSET SETTLING RESPONSE
(+8dB BB VGA GAIN STEP)**

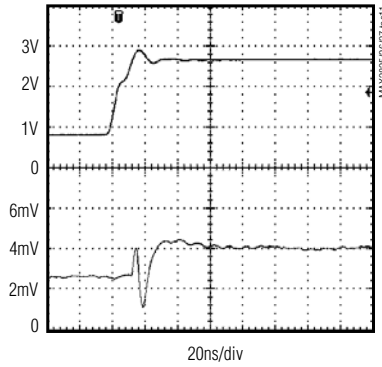

**RX I/Q DC OFFSET SETTLING RESPONSE
(-16dB BB VGA GAIN STEP)**

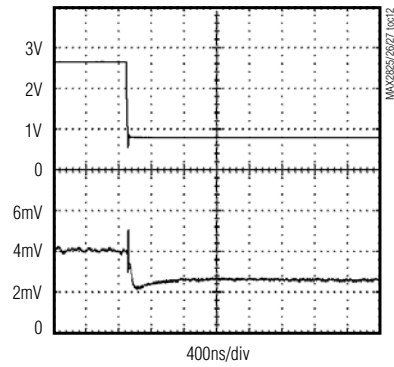

**RX I/Q DC OFFSET SETTLING RESPONSE
(-32dB BB VGA GAIN STEP)**

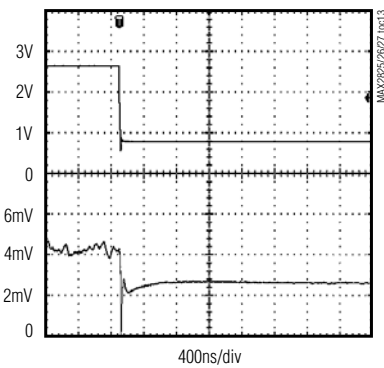

RX EVM vs. P_{IN}

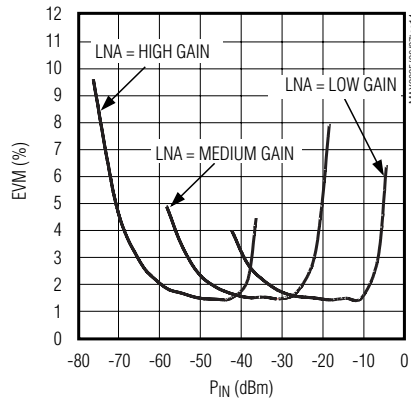

RX EVM vs. V_{OUT}

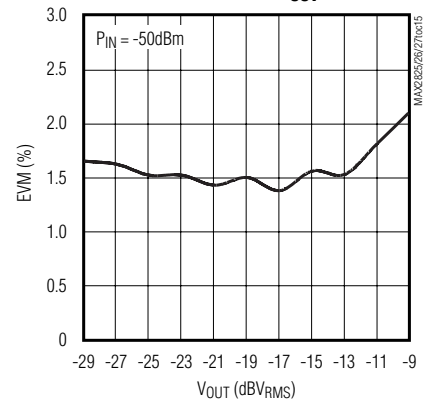

**TX OUTPUT POWER vs. V_{CC}
(B6:B1 = 111111)**

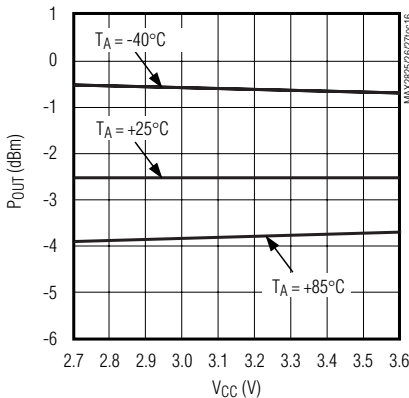

**TX OUTPUT POWER vs. FREQUENCY
(B6:B1 = 111111)**

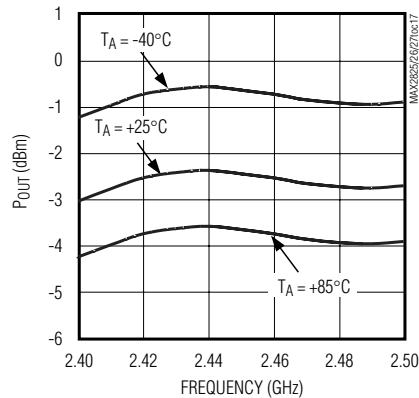

**TX OUTPUT SPECTRUM
(54Mbps OFDM SIGNAL)**

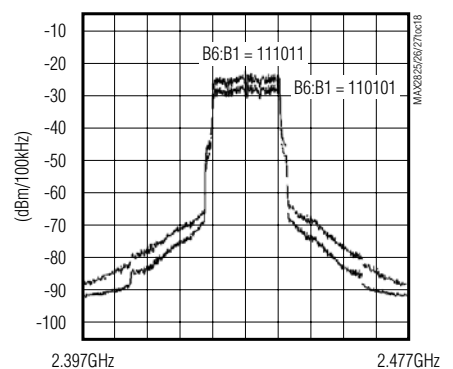

2.4GHz/5GHz、单频和双频、 802.11g/a RF收发器芯片

典型工作特性 (续)

($V_{CC} = 2.7V$, $f_{RF} = 2.437GHz$ (802.11g) or $f_{RF} = 5.25GHz$ (802.11a), $f_{REFOSC} = 40MHz$, $\overline{SHDN} = \overline{CS} = high$, $RXHP = SCLK = DIN = low$, $R_{BIAS} = 11k\Omega$, $T_A = +25^\circ C$, using the MAX2825/MAX2826/MAX2827 Evaluation Kits.)

802.11g

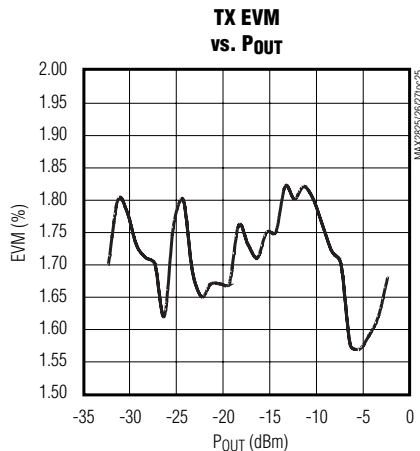
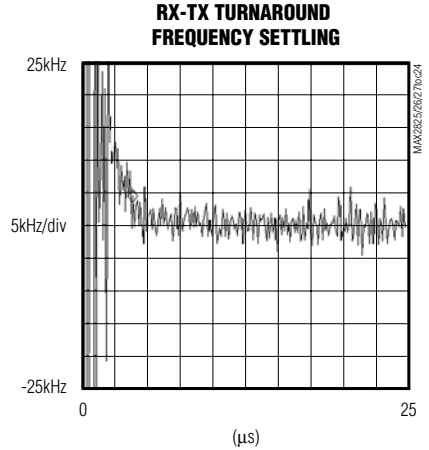
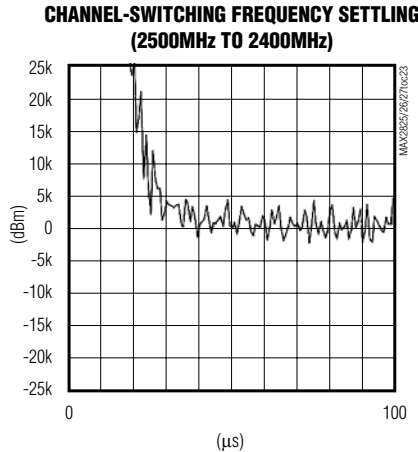
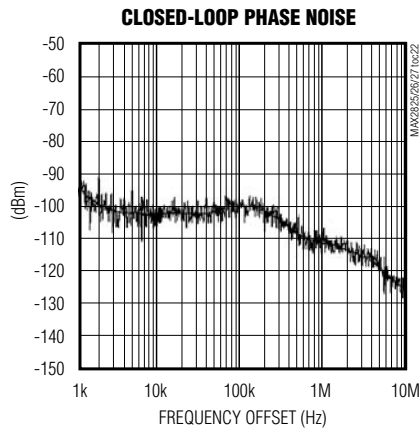
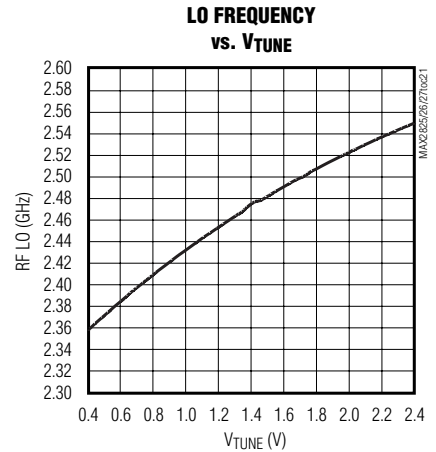
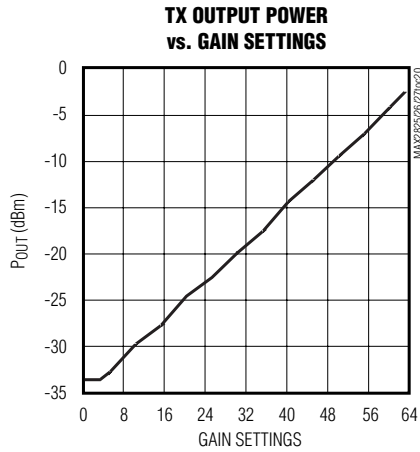
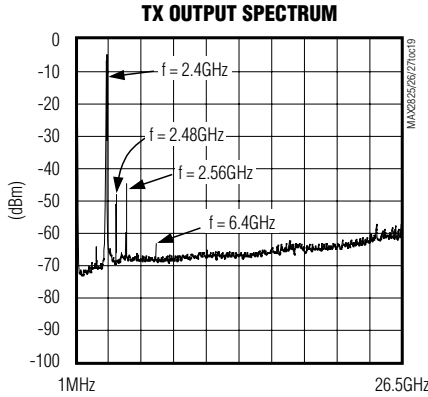

2.4GHz/5GHz、单频和双频、 802.11g/a RF收发器芯片

典型工作特性 (续)

($V_{CC} = 2.7V$, $f_{RF} = 2.437GHz$ (802.11g) or $f_{RF} = 5.25GHz$ (802.11a), $f_{REFOSC} = 40MHz$, $\overline{SHDN} = \overline{CS} = high$, $RXHP = SCLK = DIN = low$, $R_{BIAS} = 11k\Omega$, $T_A = +25^\circ C$, using the MAX2825/MAX2826/MAX2827 Evaluation Kits.)

802.11g

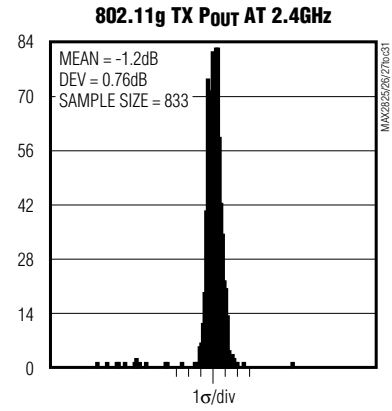
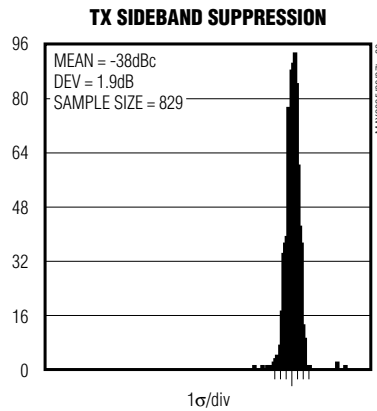
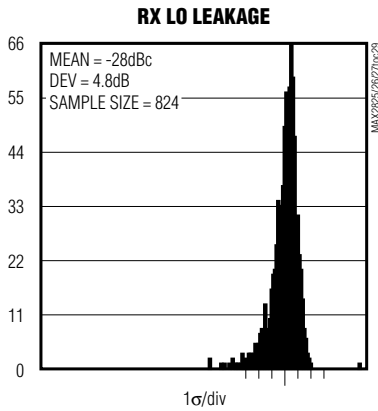
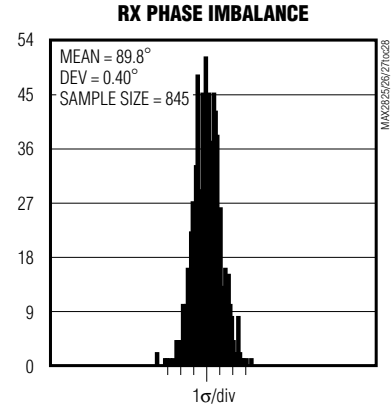
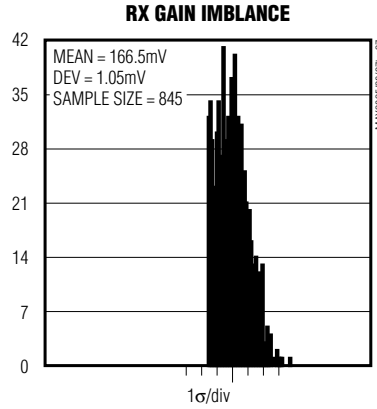
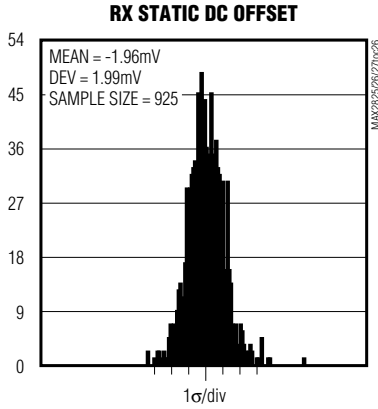

MAX2825/MAX2826/MAX2827

2.4GHz/5GHz、单频和双频、 802.11g/a RF收发器芯片

典型工作特性 (续)

($V_{CC} = 2.7V$, $f_{RF} = 2.437GHz$ (802.11g) or $f_{RF} = 5.25GHz$ (802.11a), $f_{REFOSC} = 40MHz$, $\overline{SHDN} = \overline{CS} = high$, $RXHP = SCLK = DIN = low$, $R_{BIAS} = 11k\Omega$, $T_A = +25^\circ C$, using the MAX2825/MAX2826/MAX2827 Evaluation Kits.)

802.11a

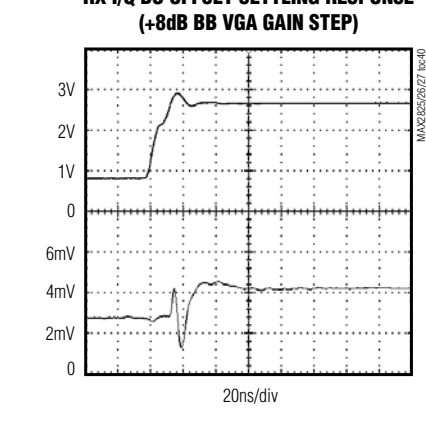
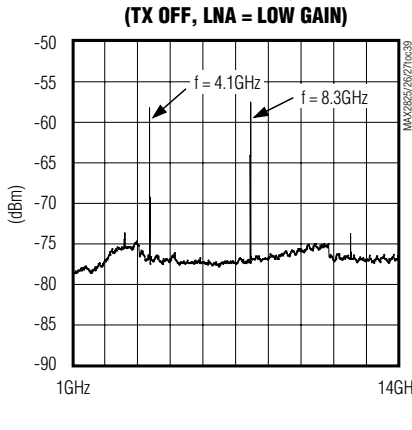
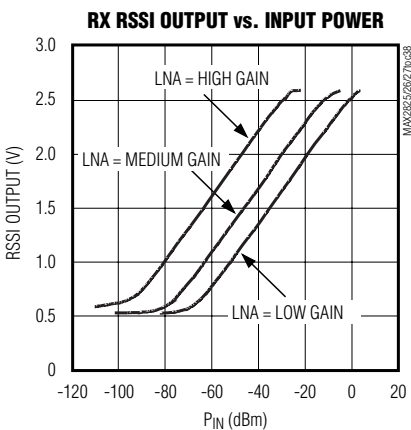
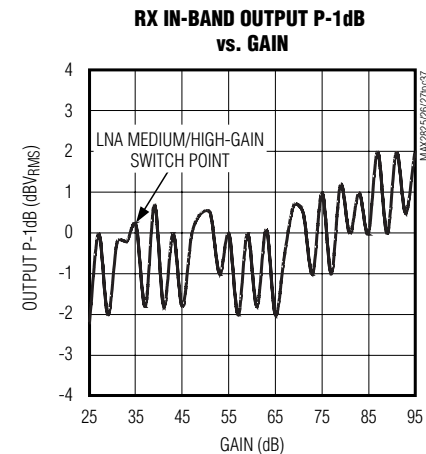
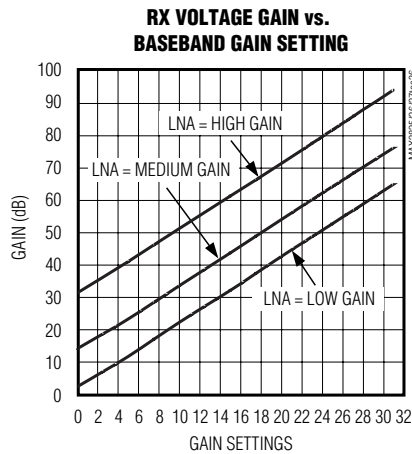
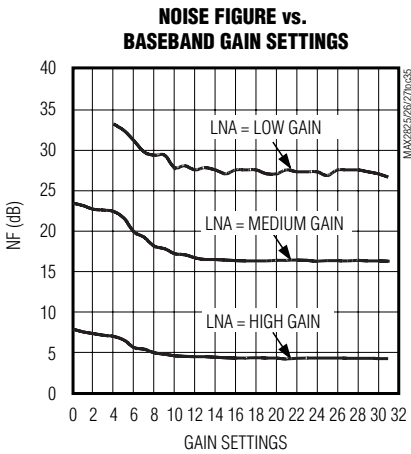
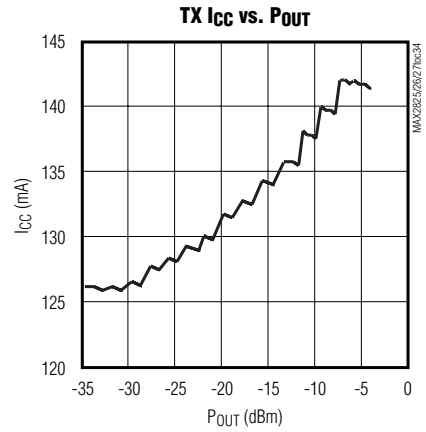
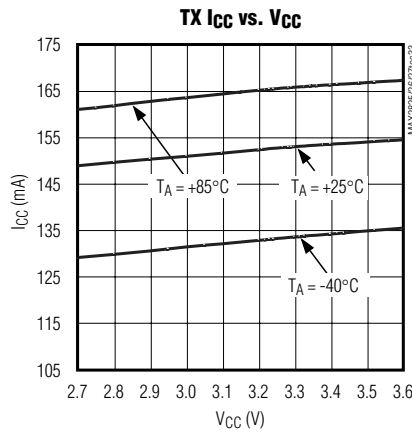
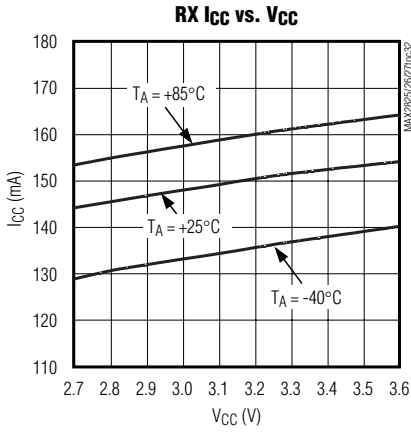

2.4GHz/5GHz、单频和双频、 802.11g/a RF收发器芯片

典型工作特性 (续)

($V_{CC} = 2.7V$, $f_{RF} = 2.437GHz$ (802.11g) or $f_{RF} = 5.25GHz$ (802.11a), $f_{REFOSC} = 40MHz$, $\overline{SHDN} = \overline{CS} = high$, $RXHP = SCLK = DIN = low$, $R_{BIAS} = 11k\Omega$, $T_A = +25^\circ C$, using the MAX2825/MAX2826/MAX2827 Evaluation Kits.)

802.11a

**RX I/Q DC OFFSET SETTLING RESPONSE
(-8dB BB VGA GAIN STEP)**

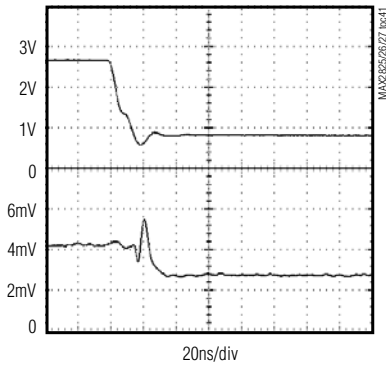

**RX I/Q DC OFFSET SETTLING RESPONSE
(-16dB BB VGA GAIN STEP)**

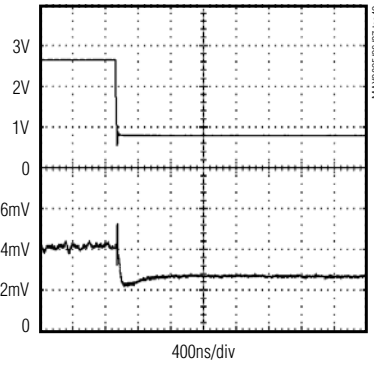

**RX I/Q DC OFFSET SETTLING RESPONSE
(-32dB BB VGA GAIN STEP)**

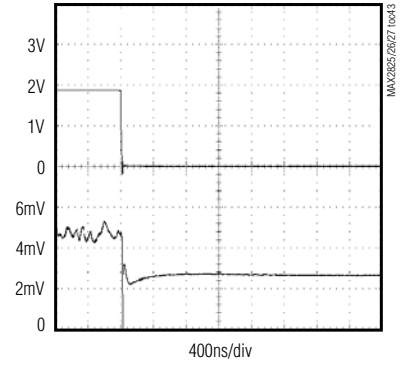

RX EVM vs. P_{IN}

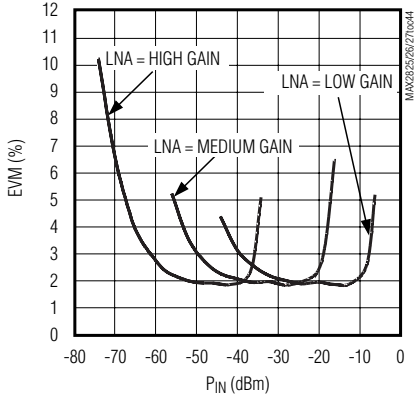

RX EVM vs. V_{OUT}

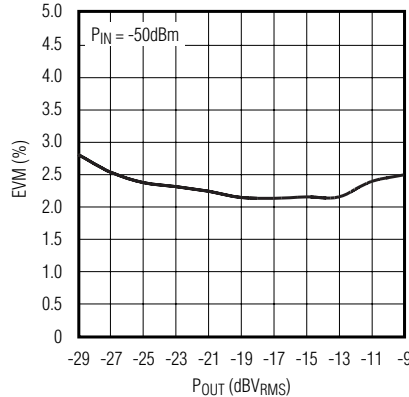

**TX OUTPUT POWER vs. V_{CC}
(B6:B1 = 111111)**

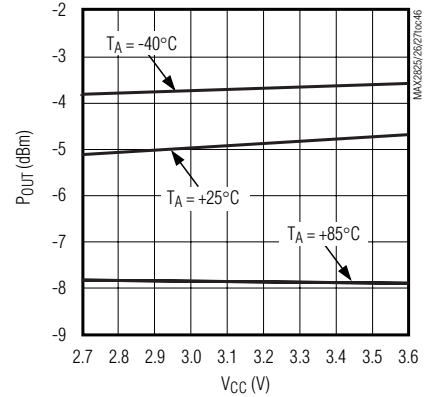

**TX OUTPUT POWER vs. FREQUENCY
(B6:B1 = 111111)**

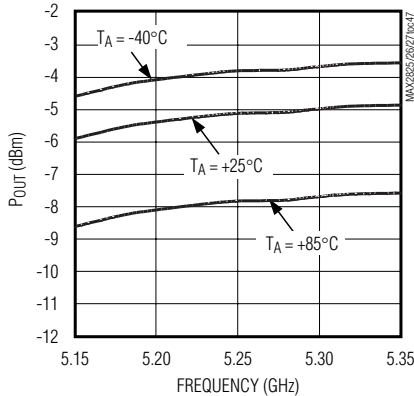

**TX OUTPUT SPECTRUM
(54Mbps OFDM SIGNAL)**

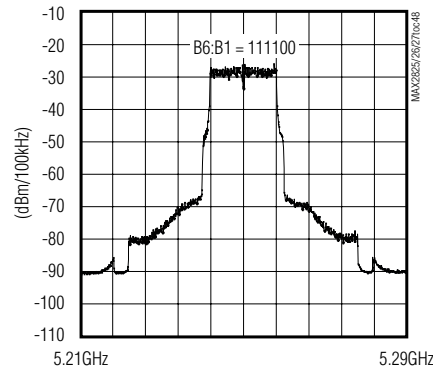

TX OUTPUT SPECTRUM

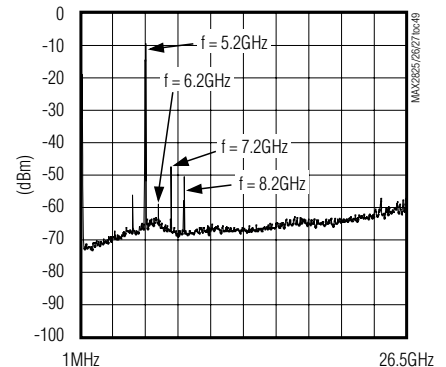

2.4GHz/5GHz、单频和双频、 802.11g/a RF收发器芯片

典型工作特性 (续)

($V_{CC} = 2.7V$, $f_{RF} = 2.437GHz$ (802.11g) or $f_{RF} = 5.25GHz$ (802.11a), $f_{REFOSC} = 40MHz$, $\overline{SHDN} = \overline{CS} = high$, $RXHP = SCLK = DIN = low$, $R_{BIAS} = 11k\Omega$, $T_A = +25^\circ C$, using the MAX2825/MAX2826/MAX2827 Evaluation Kits.)

802.11a

**TX OUTPUT POWER
vs. GAIN SETTINGS**

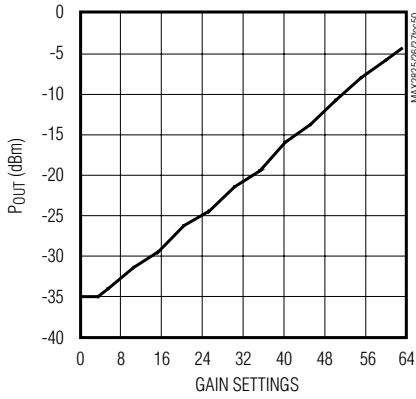

**LO FREQUENCY
vs. VTUNE**

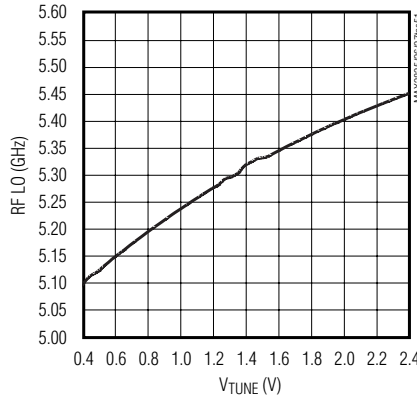

CLOSED-LOOP PHASE NOISE

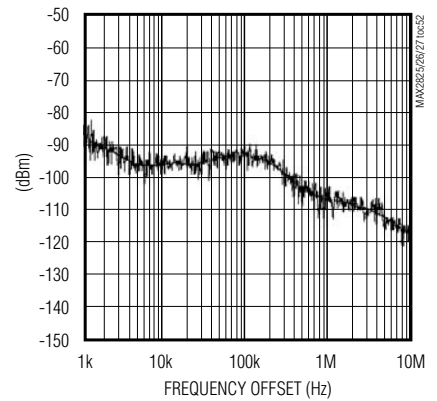

**CHANNEL-SWITCHING FREQUENCY SETTLING
(5.35GHz TO 5.15GHz)**

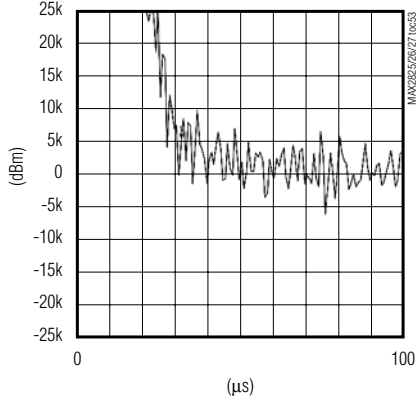

**TX-RX TURNAROUND
FREQUENCY SETTLING**

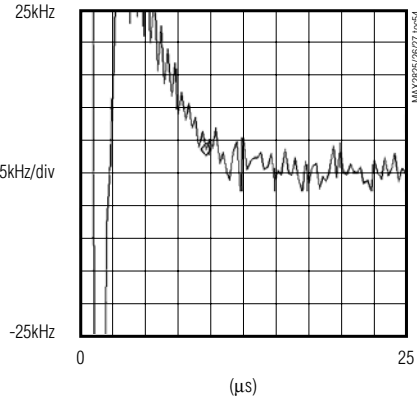

**TX EVM
vs. POUT**

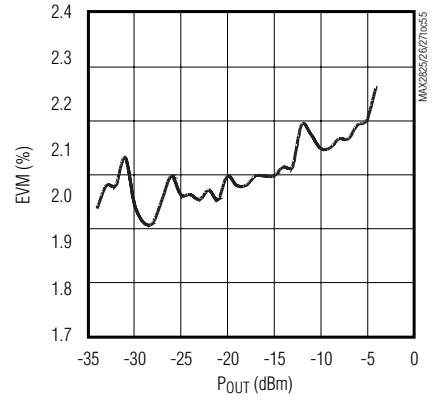

2.4GHz/5GHz、单频和双频、 802.11g/a RF收发器芯片

典型工作特性 (续)

($V_{CC} = 2.7V$, $f_{RF} = 2.437GHz$ (802.11g) or $f_{RF} = 5.25GHz$ (802.11a), $f_{REFOSC} = 40MHz$, $\overline{SHDN} = \overline{CS} = high$, $RXHP = SCLK = DIN = low$, $RBIAS = 11k\Omega$, $T_A = +25^\circ C$, using the MAX2825/MAX2826/MAX2827 Evaluation Kits.)

802.11a

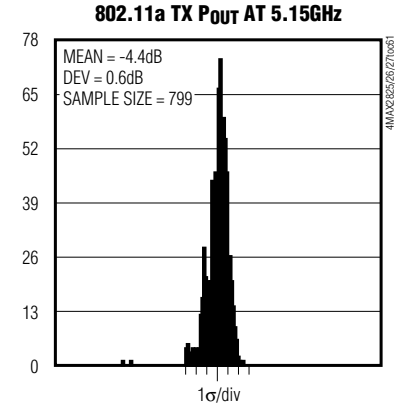
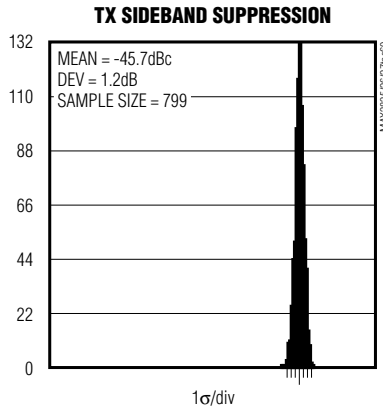
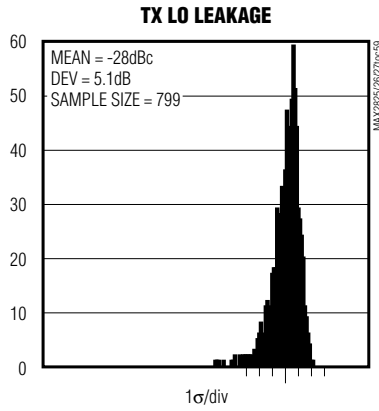
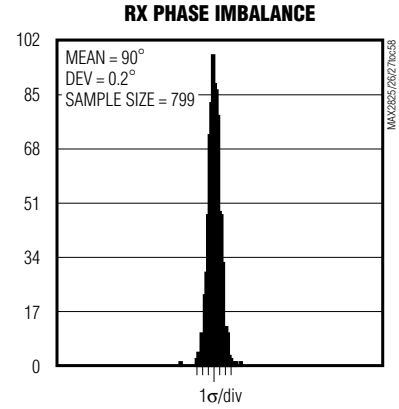
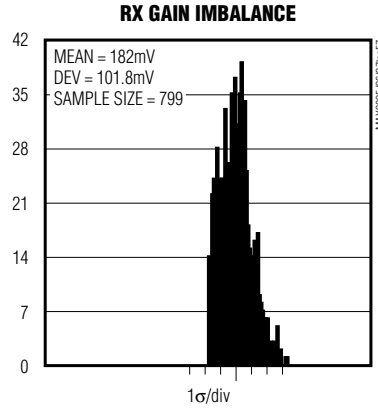
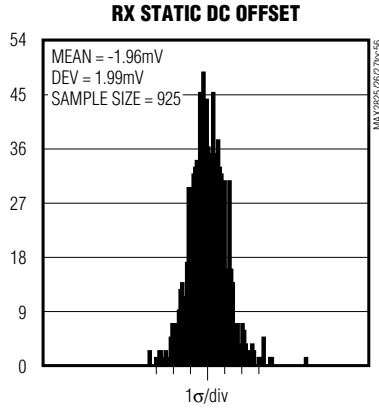

MAX2825/MAX2826/MAX2827

2.4GHz/5GHz、单频和双频、 802.11g/a RF收发器芯片

典型工作特性 (续)

($V_{CC} = 2.7V$, $f_{RF} = 2.437GHz$ (802.11g) or $f_{RF} = 5.25GHz$ (802.11a), $f_{REFOSC} = 40MHz$, $\overline{SHDN} = \overline{CS} = high$, $RXHP = SCLK = DIN = low$, $R_{BIAS} = 11k\Omega$, $T_A = +25^\circ C$, using the MAX2825/MAX2826/MAX2827 Evaluation Kits.)

802.11g/802.11a

**I/Q OUTPUT DC ERROR DROOP
(RXHP = 1-0; A3:A1 = 1000, D2 = 0)**

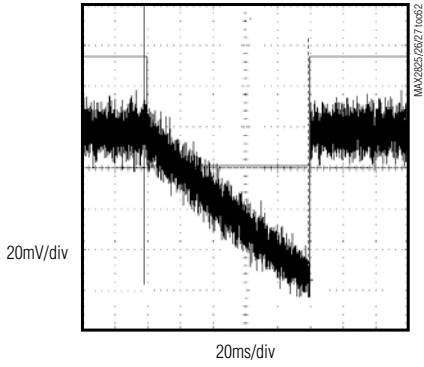

**RX RSSI STEP RESPONSE
(+40dB SIGNAL STEP)**

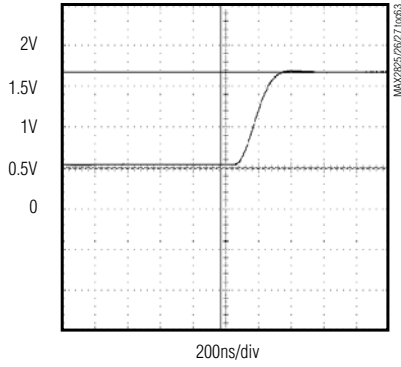

**RX RSSI STEP RESPONSE
(-40dB SIGNAL STEP)**

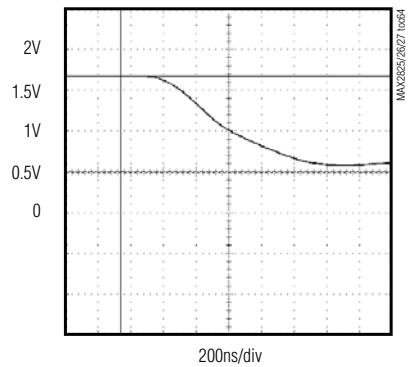

**RX BB VGA SETTLING RESPONSE
(+8dB GAIN STEP)**

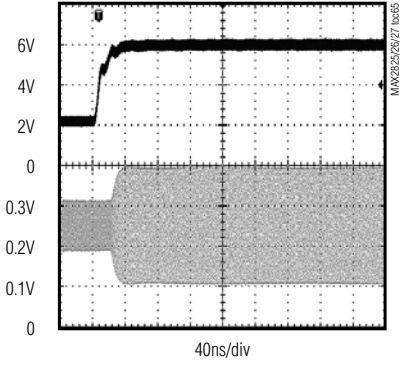

**RX BB VGA SETTLING RESPONSE
(-8dB GAIN STEP)**

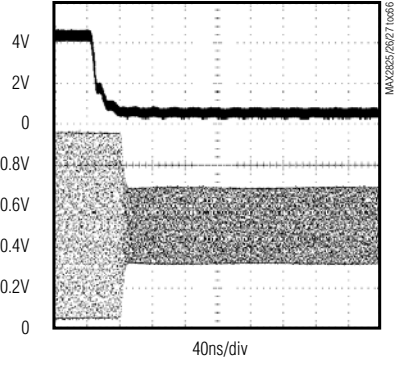

**RX BB VGA SETTLING RESPONSE
(-16dB GAIN STEP)**

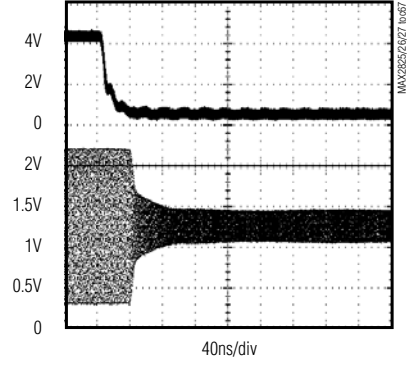

**RX BB VGA SETTLING RESPONSE
(-32dB GAIN STEP)**

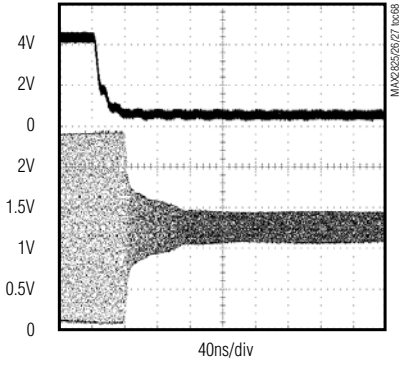

**RX BB FREQUENCY RESPONSE vs.
FINE SETTING (COARSE SETTING = 9.5MHz)**

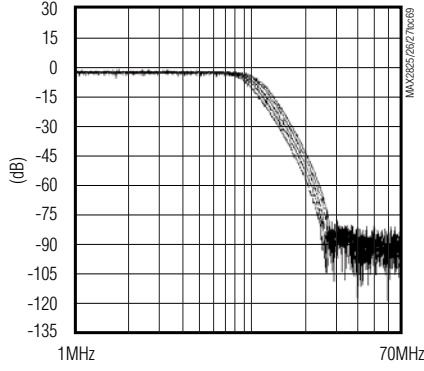

2.4GHz/5GHz、单频和双频、 802.11g/a RF收发器芯片

典型工作特性 (续)

($V_{CC} = 2.7V$, $f_{RF} = 2.437GHz$ (802.11g) or $f_{RF} = 5.25GHz$ (802.11a), $f_{REFOSC} = 40MHz$, $\overline{SHDN} = \overline{CS} = \text{high}$, $RXHP = SCLK = DIN = \text{low}$, $R_{BIAS} = 11k\Omega$, $T_A = +25^\circ C$, using the MAX2825/MAX2826/MAX2827 Evaluation Kits.)

802.11g/802.11a

MAX2825/MAX2826/MAX2827

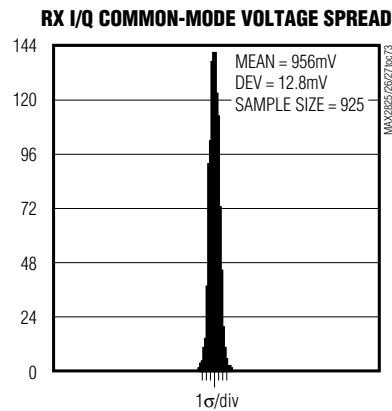
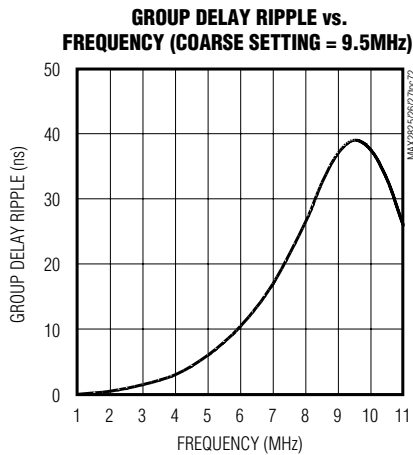
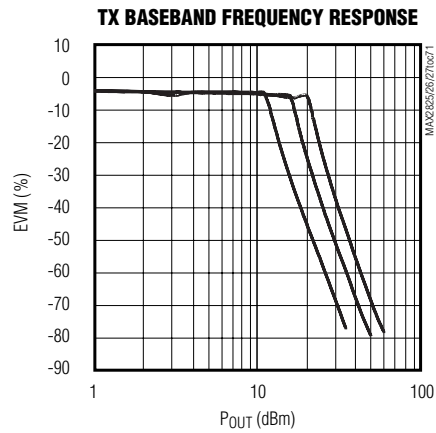
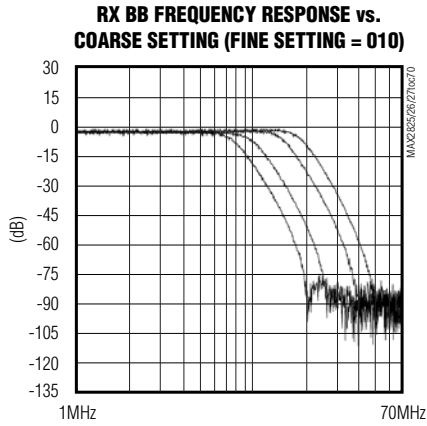

2.4GHz/5GHz、单频和双频、 802.11g/a RF收发器芯片

引脚说明

引脚			名称	功能
MAX2825	MAX2826	MAX2827		
1	1	1	B6	Rx 前端和 Tx 增益控制数字输入第 6 位。
2	2	2	VCC	2.4GHz/5GHz LNA 电源电压。需接旁路电容，且旁路电容应尽可能靠近该引脚。旁路电容的接地过孔不能与其它支路共用。
3	3	3	B7	Rx 前端增益控制数字输入第 7 位。
4	—	4	RXRFL	2.4GHz 单端 LNA 输入。需要外部匹配网络。
5, 7	5, 7	5, 7	GND	LNA 地。连接到地过孔的连线应尽可能短。接地过孔不能与其它支路共用。
6, 8, 9	4, 11, 12	—	N.C.	不连接
—	6	6	RXRFH	5GHz 单端 LNA 输入。需要外部匹配网络。
—	8	8	TXRFH+	5GHz Tx PA 驱动器差分输出。PA 输入端需要外部匹配网络 (和非平衡变压器)。
—	9	9	TXRFH-	
10	10	10	VCC	Tx RF 电源电压。需接旁路电容，且旁路电容应尽可能靠近该引脚。旁路电容的接地过孔不能与其它支路共用。
11	—	11	TXRFL+	2.4GHz Tx PA 驱动器差分输出。PA 输入端需要外部匹配网络 (和非平衡变压器)。
12	—	12	TXRFL-	
13	13	13	TXENA	Tx 模式使能输入。设置为高电平使能发送器。见图 1。
14	14	14	PABIAS	DAC 输出。连接到外部 PA 偏置引脚。
15	15	15	VCC	Tx 基带滤波器电源电压。需接旁路电容，且旁路电容应尽可能靠近该引脚。旁路电容的接地过孔不能与其它支路共用。
16	16	16	TXBBI+	Tx 基带 I 通道差分输入。
17	17	17	TXBBI-	
18	18	18	TXBBQ+	Tx 基带 Q 通道差分输入。
19	19	19	TXBBQ-	
20	20	20	VCC	Tx 上变频器电源电压。旁路电容的接地过孔不能与其它支路共用。
21	21	21	RBIAS	模拟电压输入由内部偏置在带隙电压。该引脚到地之间接 11kΩ 的精密电阻或电流源设置器件的偏置电流。
22	22	22	VCC	基准电路电源电压。需接旁路电容，且旁路电容应尽可能靠近该引脚。旁路电容的接地过孔不能与其它支路共用。
23	23	23	VREF	基准电压输出
24	24	24	GND	数字电路地。与接地过孔的连线应尽可能短。接地过孔不能与其它支路共用。

2.4GHz/5GHz、单频和双频、 802.11g/a RF收发器芯片

引脚说明 (续)

引脚			名称	功能
MAX2825	MAX2826	MAX2827		
25	25	25	VCC	数字电路电源电压。需接旁路电容，且旁路电容应尽可能靠近该引脚。旁路电容的接地过孔不能与其它支路共用。
26	26	26	DIN	3线串行接口的数据输入 (见图2)。
27	27	27	SCLK	3线串行接口的时钟输入 (见图2)。
28	28	28	\overline{CS}	3线串行接口的使能输入 (见图2)。
29	29	29	LD	频率合成器的锁定检测数字输出。输出高电平表示频率合成器被锁定。
30	30	30	ROSC	参考振荡器输入，将外部参考振荡器或晶振连接到此模拟输入引脚。
31	31	31	VCC	PLL电荷泵电源电压。需接旁路电容，且旁路电容应尽可能靠近该引脚。旁路电容的接地过孔不能与其它支路共用。
32	32	32	GND	电荷泵电路地。连接到地过孔的连线应尽可能短。地过孔不能与其它支路共用。
33	33	33	CPOUT	电荷泵输出。在CPOUT和TUNE引脚之间接频率合成器的环路滤波器。该引脚与调谐输入之间的连线应尽可能短，以避免拾取杂散信号。C2需尽可能靠近CPOUT连接。电容的接地过孔不能与其它支路共用。见典型工作电路。
34	34	34	GND	地。与地过孔的连线应尽可能短。接地过孔不能与其它支路共用。
35	35	35	GND	VCO地。与地过孔的连线应尽可能短。接地过孔不能与其它支路共用。
36	36	36	TUNE	VCO TUNE输入。C1应尽可能靠近TUNE连接。C1的地与VCO地连接在一起。电容接地过孔不能与其它支路共用。见典型工作电路。
37	37	37	BYPASS	用0.1 μ F电容旁路接地。这个电容用于片内VCO稳压器。
38	38	38	VCC	VCO电源电压。需靠近该引脚接旁路电容至系统地。旁路电容的接地过孔不能与其它支路共用。
39	39	39	\overline{SHDN}	关断输入。设置为高电平时使能器件。
40	40	40	RSSI	RSSI或温度传感器复用输出
41	41	41	RXENA	Rx模式使能输入。设置为高电平时使能Rx。
42	42	42	RXHP	Rx基带交流耦合高通滤波器转角频率的控制输入选择位。
43	43	43	RXBBQ-	Rx基带Q通道差分输出。在Tx校准模式下，这些引脚为本振泄漏和边带检测输出。
44	44	44	RXBBQ+	

MAX2825/MAX2826/MAX2827

2.4GHz/5GHz、单频和双频、 802.11g/a RF收发器芯片

引脚说明 (续)

引脚			名称	功能
MAX2825	MAX2826	MAX2827		
45	45	45	RXBBI-	Rx 基带 I 通道差分输出。在 Tx 校准模式中，这些引脚为本振泄漏和边带检测输出。
46	46	46	RXBBI+	
47	47	47	VCC	Rx 基带缓冲器电源电压。需接旁路电容，且旁路电容应尽可能靠近该引脚。旁路电容的接地过孔不能与其它支路共用。
48	48	48	B1	Rx/Tx 增益控制数字输入第 1 位。
49	49	49	VCC	Rx 基带滤波器电源电压。需接旁路电容，且旁路电容应尽可能靠近该引脚。旁路电容的接地过孔不能与其它支路共用。
50	50	50	B2	Rx/Tx 增益控制数字输入第 2 位。
51	51	51	GND	Rx IF 地。与地过孔的连线应尽可能短。接地过孔不能与其它支路共用。
52	52	52	VCC	Rx IF 电源电压。需接旁路电容，且旁路电容应尽可能靠近该引脚。旁路电容的接地过孔不能与其它支路共用。
53	53	53	B3	Rx/Tx 增益控制数字输入第 3 位。
54	54	54	B4	Rx/Tx 增益控制数字输入第 4 位。
55	55	55	VCC	Rx 下变频器电源电压。需接旁路电容，且旁路电容应尽可能靠近该引脚。旁路电容的接地过孔不能与其它支路共用。
56	56	56	B5	Rx/Tx 增益控制数字输入第 5 位。
裸露焊盘	裸露焊盘	裸露焊盘	EP	为保证系统正常工作，提供适当的散热，使用多个过孔连接到地平面。

详细说明

MAX2825/MAX2826/MAX2827 为单片 RF 收发器 IC，为 WLAN 应用而设计。MAX2825 设计用于单频 2.4GHz 802.11g (OFDM 和 CCK)；MAX2826 用于单频 5GHz 802.11a (OFDM)；MAX2827 的双频功能对 802.11a 和 802.11g 应用非常理想。这些芯片包含了所有实现 RF 收发器功能的电路，提供完全集成的接收通路、发送通路、VCO、频率合成器以及基带/控制接口。

工作模式

MAX2825/MAX2826/MAX2827 具有七种主要工作模式：关断、SPI 复位、待机、发送、接收、发送器校准以及接收器校准 (见表 5)。

关断模式

将寄存器设置为 A3:A0 = 0001，D9 置为 1，然后将 $\overline{\text{SHDN}}$ 拉为低电平即可进入关断模式。在退出 $\overline{\text{SHDN}}$ 后，设置 D9 = 0。关断模式下，除串行接口外其它所有电路模块均为断电状态，电流消耗降至 10 μ A (典型值)。在器件处于关断模式时，只要第 25 引脚 V_{CC} 加电，将保持串行接口寄存器的值。串行接口寄存器还可通过 V_{CC} 加电装载。

SPI 复位

$\overline{\text{SHDN}}$ 置为低电平时，将 RXENA 和 TXENA 驱动为高电平，与关断模式一样，所有电路模块均为断电状态。然而，在 SPI 复位时，所有寄存器将返回到缺省状态。建议在上电时复位 SPI 和所有寄存器，以保证寄存器设置正确 (见表 6)。

2.4GHz/5GHz、单频和双频、 802.11g/a RF收发器芯片

MAX2825/MAX2826/MAX2827



图1. 系统时序图



图2.3 线串行接口时序图

2.4GHz/5GHz、单频和双频、 802.11g/a RF收发器芯片

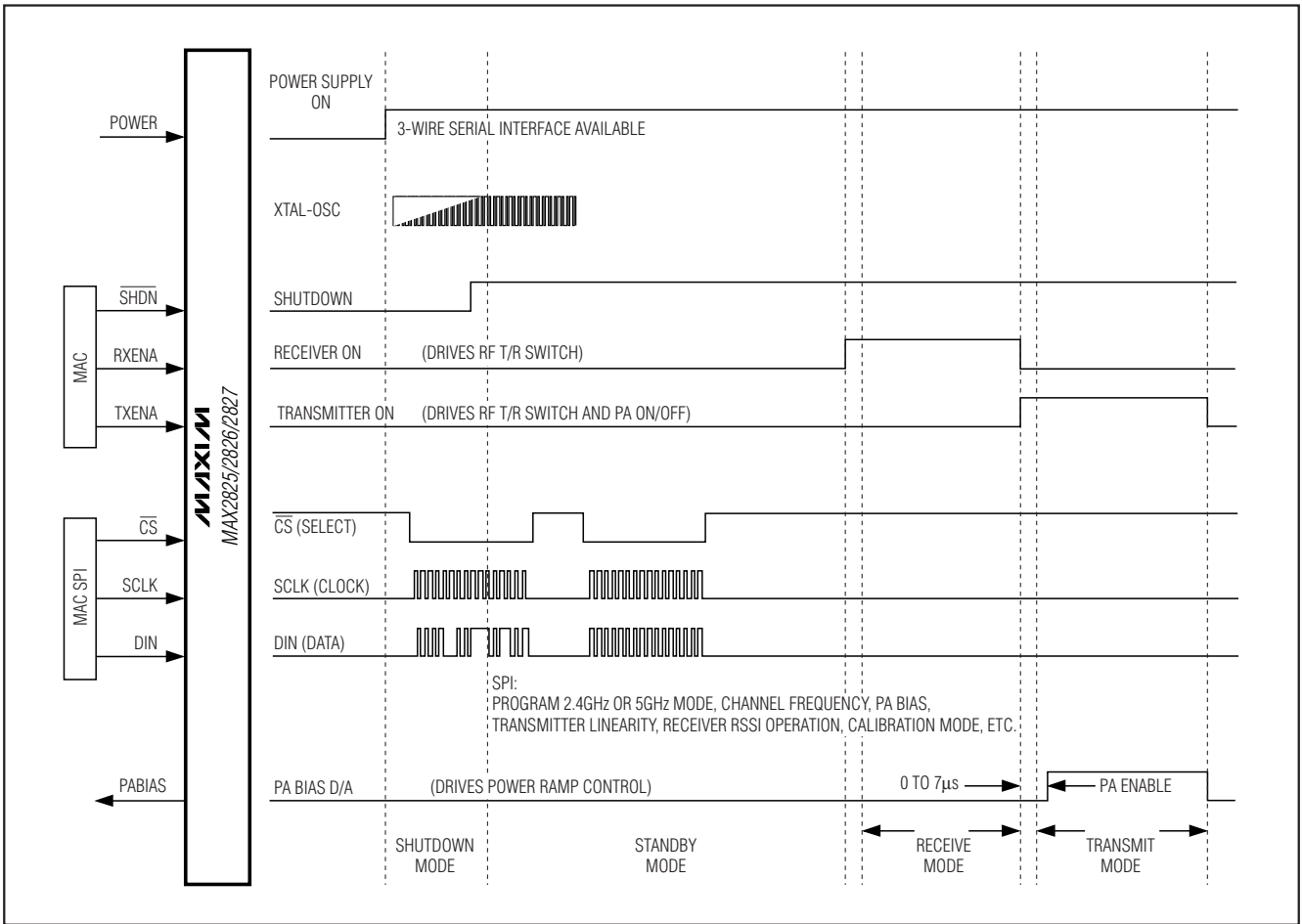
表5. 模式表

MODE	LOGIC PINS			REGISTER SETTINGS
	SHDN	TXENA	RXENA	
SPI Reset	0	1	1	X
Shutdown	0	0	0	A3:A0 = 0001, D9 = 1
Standby	1	0	0	X
Rx	1	0	1	A3:A0 = 0001, D2 = 0
Tx	1	1	0	X
Tx Calibration	1	1	0	Standby register D6 = 1; Calibration register D1 = 1
Rx Calibration	1	0	1	Calibration register D0 = 1

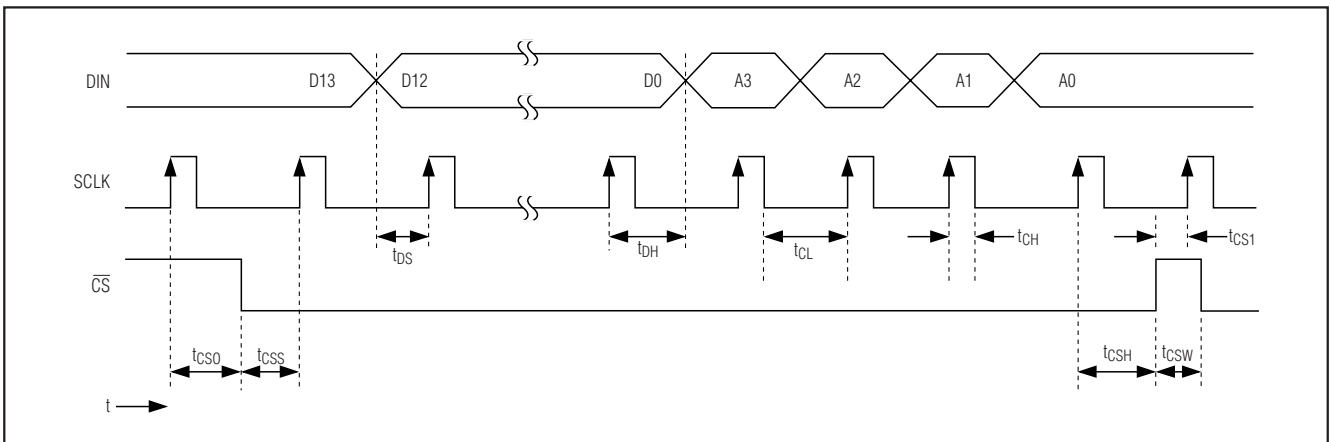
X = 无关或不起作用。

表6. 寄存器缺省值/SPI复位设置

REGISTER	DEFAULT														ADDRESS	TABLE
	D13	D12	D11	D10	D9	D8	D7	D6	D5	D4	D3	D2	D1	D0	(A3:A0)	
Register 0	0	1	0	0	0	1	0	1	0	0	0	0	0	0	0000	—
Register 1	0	0	0	0	0	0	1	1	0	0	1	1*	1	0	0001	—
Standby	0	1	0	0	0	0	0	0	0	0	0	1	1	1	0010	7
Integer-Divider Ratio	1	1	0	0	0	0	1	0	1	0	0	0	1	0	0011	8
Fractional-Divider Ratio	0	1	1	1	0	1	1	1	0	1	1	1	0	1	0100	9
Band-Select and PLL	0	1	1	0	0	1	0	1	1	0	0	1	0	0	0101	10
Calibration	0	1	1	1	0	0	0	0	0	0	0	0	0	0	0110	11
Lowpass Filter	0	0	0	0	0	0	0	0	1	0	1	0	1	0	0111	12
Rx Control/RSSI	0	0	0	0	0	0	0	0	1	0	0	1	0	1	1000	13
Tx Linearity/Baseband Gain	0	0	0	0	1	0	0	0	0	0	0	0	0	0	1001	14
PA Bias DAC	0	0	0	0	1	1	1	1	0	0	0	0	0	0	1010	15
Rx Gain	0	0	0	0	0	0	0	1	1	1	1	1	1	1	1011	16
Tx VGA Gain	0	0	0	0	0	0	0	0	0	0	0	0	0	0	1100	17

* 编程为0。

待机模式

SHDN置为高电平，RXENA和TXENA为低电平时，器件进入待机模式。该模式主要用于开启频率合成器、关断其余电路。在此模式下，系统的各部分电路可根据待机寄存器表(表7)选择开启或关闭。

接收(Rx)模式

RXENA置为高电平时，器件进入Rx模式。在此模式下所有接收电路被使能。退出SPI复位模式时，编程A3:A0 = 0001，D2 = 0。

发送(Tx)模式

TXENA置为高电平时，器件进入Tx模式。该模式下所有发送电路被使能。

Tx/Rx校准模式

MAX2825/MAX2826/MAX2827具有Tx/Rx校准功能，可检测I/Q不平衡性和发送本振泄漏。在Tx校准模式下，仅对通道中心频率的本振泄漏信号(即OFDM或QPSK频谱中心)进行本振泄漏校准。本振泄漏校准包括I/Q调制器的整个基带通道的所有直流失调，也包括本振到I/Q调制器输出的直接泄漏。

校准过程中，在接收器的I或Q通道输出端获取本振泄漏和边带检测输出。为了正常工作，需要使能接收器的基带电路(表7)。

2.4GHz/5GHz、单频和双频、 802.11g/a RF收发器芯片

表 7. 待机寄存器 (A3:A0 = 0010)

DATA BIT	DEFAULT	DESCRIPTION
D13	0	Set to 0
D12	1	Set to 1
D11	0	Voltage Reference
D10	0	PA Bias DAC
D9	0	Set to 0
D8	0	
D7	0	
D6	0	Rx Baseband (Excluding RSSI)
D5	0	Set to 0
D4	0	
D3	0	Autotuner. (1 performs a single cycle autotuning, then switches off.)
D2	1	Set to 1
D1	1	
D0	1	

在 Tx 本振泄漏和 I/Q 不平衡校准期间，正弦信号和余弦信号 ($f = f_{\text{TONE}}$) 从基带 IC 输入到基带 I/Q 的 Tx 引脚。在本振泄漏和边带检测输出端，本振泄漏对应于信号 f_{TONE} ，而边带抑制对应于信号 $2 \times f_{\text{TONE}}$ 。本振泄漏和边带抑制变化 1dB，这些信号的输出功率也跟着变化 1dB。为了校准 Tx 通路，首先设置功率检测器增益为 8dB (表 11)。调节基带输入的直流失调以减小 f_{TONE} 处的信号 (本振泄漏)。然后调节基带输入的相关幅度和相位偏差，从而减小 $2 \times f_{\text{TONE}}$ 处的信号。如果需要，可使用更高的本振泄漏和边带检测增益设置进行校准，以降低本振泄漏、增强镜频抑制。

在 Rx 校准模式下，校准 Tx RF 信号由内部切换到 Rx 下变频输入。在这个环路校准模式下，稳压器必须能够提供 350mA 的电流，因为 Tx 和 Rx 同时工作。

可编程寄存器

MAX2825/MAX2826/MAX2827 包括 13 个可编程的 18 位寄存器：0、1、待机、整数分频比、分数分频比、频段选择和 PLL、校准、低通滤波器、Rx 控制/RSSI、Tx 线性/基带增益、PA 偏置 DAC、Rx 增益和 Tx VGA 增益 (表 6)。

表 8. 整数分频比寄存器
(A3:A0 = 0011)

DATA BIT	DEFAULT	DESCRIPTION
D13	1	2 LSBs of the Fractional-Divider Ratio
D12	1	
D11	0	Set to 0
D10	0	
D9	0	
D8	0	
D7	1	Integer-Divider Ratio Word-Programming Bits. Valid values are from 128 (D7:D0 = 10000000) to 255 (D7:D0 = 11111111).
D6	0	
D5	1	
D4	0	
D3	0	
D2	0	
D1	1	
D0	0	

高 14 位 (MSB) 用作寄存器数据，每个寄存器的低 4 位 (LSB) 包含寄存器地址。先移入高位数据。发送到器件的 18 位数据字由 $\overline{\text{CS}}$ 控制成一帧。当 $\overline{\text{CS}}$ 为低电平时，时钟有效，在时钟上升沿数据移入器件。当 $\overline{\text{CS}}$ 变为高电平时，移位寄存器的值锁存到由地址位选择的寄存器中。移位寄存器中仅保留最后移入器件的 18 位数据，不对时钟脉冲数进行检查。编程数据少于 14 位时，仅要求对需要的数据位和地址位移位，即在增益控制中仅需要设置低位时，可实现更快的 Rx 和 Tx 增益控制。通过 3 线 SPI™/MICROWIRE™ 兼容串行接口进行编程。

启动时，建议设置器件为 SPI 复位模式，将所有寄存器复位 (表 5)。

待机寄存器定义 (A3:A0 = 0010)

各部分内部电路可使用待机寄存器 (待机模式下，见表 7) 开启或关闭。对应位置为“1”开启电路，置为“0”关闭电路。

整数分频比寄存器定义 (A3:A0 = 0011)

此寄存器包含频率合成器分频比的整数部分，配合分数分频比寄存器，可选择精确的频率。主频率合成器分频比是对应整数部分的 8 位数值 (见表 8)。该寄存器有效值

2.4GHz/5GHz、单频和双频、 802.11g/a RF收发器芯片

表 9a. IEEE 802.11g 频率规划和分频比编程字

f _{RF} (MHz)	(f _{RF} X 4/3) / 20MHz (DIVIDER RATIO)	INTEGER-DIVIDER RATIO	FRACTIONAL-DIVIDER RATIO	
		A3:A0 = 0011, D7:D0	A3:A0 = 0100, D13:D0	A3:A0 = 0011, D13:D12
2412	160.8000	1010 0000	3333	00
2417	161.1333	1010 0001	0888	10
2422	161.4667	1010 0001	1DDD	11
2427	161.8000	1010 0001	3333	00
2432	162.1333	1010 0010	0888	10
2437 (default)	162.4667	1010 0010	1DDD	11
2442	162.8000	1010 0010	3333	00
2447	163.1333	1010 0011	0888	10
2452	163.4667	1010 0011	1DDD	11
2457	163.8000	1010 0011	3333	00
2462	164.1333	1010 0100	0888	10
2467	164.4667	1010 0100	1DDD	11
2472	164.8000	1010 0100	3333	00
2484	165.6000	1010 0101	2666	01

表 9b. IEEE 802.11a 频率规划和分频比编程字

f _{RF} (MHz)	(f _{RF} X 4/5) / 20MHz (DIVIDER RATIO)	INTEGER-DIVIDER RATIO	FRACTIONAL-DIVIDER RATIO	
		A3:A0 = 0011, D7:D0	A3:A0 = 0100, D13:D0	A3:A0 = 0011, D13:D12
5180	207.2	1100 1111	0CCC	11
5200	208.0	1101 0000	0000	00
5220	208.8	1101 0000	3333	00
5240	209.6	1101 0001	2666	01
5260	210.4	1101 0010	1999	10
5280	211.2	1101 0011	0CCC	11
5300	212.0	1101 0100	0000	00
5320	212.8	1101 0100	3333	00

为 128 到 255 (D7–D0)，缺省值为 162。D13 和 D12 保留用于分数分频比的 2 个最低有效位。

分数分频比寄存器定义 (A3:A0 = 0100)

此寄存器 (连同整数分频比寄存器中的 D13 和 D12) 以 16 位分辨率控制分数分频比。寄存器中的 D13 到 D0 与整数分频比寄存器中的 D13 和 D12 构成了整个分数分频比 (见表 9a 和 9b)。

频段选择和 PLL 寄存器定义 (A3:A0 = 0101)

此寄存器配置频率合成器的可编程参考频率分频器，设置电荷泵的直流电流。通过对晶振的频率进行分频，可编程参考频率分频器为鉴相器提供参考频率 (见表 10)。

2.4GHz/5GHz、单频和双频、 802.11g/a RF收发器芯片

MAX2825/MAX2826/MAX2827

表 10. 频段选择和PLL 寄存器 (A3:A0 = 0101)

DATA BIT	DEFAULT	DESCRIPTION
D13	0	Set D13:D11 = 011
D12	1	
D11	1	
D10	0	Set to 0
D9	0	
D8	1	Select the Autotuner Reference-Divider Ratio. D8:D7 = 00, 01: A = 2; 10: A = 4; 11: A = 8. Set tuner reference-divider ratio = $f_{REFOSC} / 10\text{MHz}$.
D7	0	
D6	1	Set to 1
D5	1	PLL Charge-Pump Current Select. 0: 2mA; 1: 4mA.
D4	0	Set to 0
D3	0	Set the Reference-Divider Ratio. D3:D1 = 001 corresponds to R = 1 and 111 corresponds to R = 7.
D2	1	
D1	0	
D0	0	RF Frequency Band-Select. 0: 2.4GHz Band; 1: 5GHz band.

表 11. 校准寄存器 (A3:A0 = 0110)

DATA BIT	DEFAULT	DESCRIPTION
D13	0	Set to 0
D12	1	Transmitter I/Q Calibration LO Leakage and Sideband-Detector Gain-Control Bits. D12:D11 = 00: 8dB; 01 18dB; 10: 24dB; 11: 34dB.
D11	1	
D10	1	
D9	0	Set to 0
D8	0	
D7	0	
D6	0	
D5	0	
D4	0	
D3	0	
D2	0	
D1	0	0: Tx Calibration Mode Disabled. 1: Tx calibration mode enabled (Rx outputs provide the LO leakage and sideband-detector signal). In Tx calibration mode, enable the Rx baseband (see Table 6).
D0	0	0: Rx Calibration Mode Disabled. 1: Rx calibration mode enabled.

2.4GHz/5GHz、单频和双频、 802.11g/a RF收发器芯片

表 12. 低通滤波器寄存器 (A3:A0 = 0111)

DATA BIT	DEFAULT	DESCRIPTION
D13	0	Set to 0
D12	0	
D11	0	
D10	0	
D9	0	
D8	0	
D7	0	
D6	0	Tx LPF Corner Frequency Coarse Adjustment. D6:D5 = 00: undefined; 01: 12MHz (nominal mode); 10: 18MHz (turbo mode 1); 11: 24MHz (turbo mode 2).
D5	1	
D4	0	Rx LPF Corner Frequency Coarse Adjustment. D4:D3 = 00: 7.5MHz; 01: 9.5MHz (nominal mode); 10: 14MHz (turbo mode 1); 11: 18MHz (turbo mode 2).
D3	1	
D2	0	Rx LPF Corner Frequency Fine Adjustment (Relative to the Coarse Setting). D2:D0 = 000: 90%; 001: 95%; 010: 100%; 011: 105%; 100: 110%.
D1	1	
D0	0	

表 13a. Rx控制/RSSI寄存器 (A3:A0 = 1000)

DATA BIT	DEFAULT	DESCRIPTION
D13	0	Set to 0
D12	0	Enable Rx VGA Gain Programming Serially. 0: Rx VGA gain programmed with external digital inputs (B7:B1); 1: Rx VGA gain programmed with serial data bits in the Rx gain register (D6:D0).
D11	0	RSSI Output Range. 0: low range (0.5V to 2V); 1: high range (0.5V to 2.5V).
D10	0	RSSI Operating Mode. 0: RSSI disabled if RXHP = 0, and enabled if RXHP = 1; 1: RSSI enabled independent of RXHP (see Table 13c).
D9	0	Set to 0
D8	0	RSSI Pin Function. 0: outputs RSSI signal in Rx mode; 1: outputs temperature-sensor voltage in Rx, Tx, and standby modes (see Table 13c).
D7	0	Set to 0
D6	0	
D5	1	Set to 1
D4	0	Set to 0
D3	0	
D2	1	Rx Highpass -3dB Corner Frequency when RXHP = 0. 0: 100Hz; 1: 30kHz
D1	0	Set D1:D0 = 01
D0	1	

校准寄存器定义 (A3:A0 = 0110)

此寄存器配置 Rx/Tx 校准模式。

Rx控制/RSSI寄存器定义 (A3:A0 = 1000)

此寄存器允许调节 Rx 部分和 RSSI 输出 (见表 13a 和 13b)。

低通滤波器寄存器定义 (A3:A0 = 0111)

此寄存器允许调节 Rx 和 Tx 低通滤波器的截止频率 (见表 12)。

2.4GHz/5GHz、单频和双频、 802.11g/a RF收发器芯片

表 13b. Rx 高通滤波器 -3dB 转角频率调节

RXHP	A3:A0 = 1000, D2	Rx HP -3dB CORNER FREQUENCY (Hz)
1	X	600k
0	1	30k
0	0	100

Tx 线性/基带增益寄存器定义 (A3:A0 = 1001)

此寄存器允许调节 Tx 增益和线性特性 (见表 14)。

PA 偏置 DAC 寄存器定义 (A3:A0 = 1010)

此寄存器控制偏置外部 PA 的 DAC 输出电流 (见表 15)。

Rx 增益寄存器定义 (A3:A0 = 1011)

此寄存器设置 Rx 基带和 RF 增益 (见表 16)。

Tx VGA 增益寄存器定义 (A3:A0=1100)

此寄存器设置 Tx VGA 增益 (见表 17)。

表 13c. RSSI 引脚真值表

INPUT CONDITIONS				RSSI OUTPUT
A3:A0 = 1000, D8	A3:A0 = 1000, D10	RXENA	RXHP	
0	0	0	X	No signal
0	0	1	0	No signal
0	0	1	1	RSSI
0	1	0	X	No signal
0	1	1	X	RSSI
1	X	X	X	Temperature sensor

表 14. Tx 线性/基带增益寄存器 (A3:A0 = 1001)

DATA BIT	DEFAULT	DESCRIPTION
D13	0	Set to 0
D12	0	
D11	0	
D10	0	Enable Tx VGA Gain Programming Serially. 0: Tx VGA gain programmed with external digital inputs (B6:B1); 1: Tx VGA gain programmed with data bits in the Tx gain register (D5:D0).
D9	1	PA Driver Linearity. D9:D8 = 00: 50% current (minimum linearity); 01: 63% current; 10: 78% current; 11: 100% current (maximum linearity).
D8	0	
D7	0	Tx VGA Linearity. D7:D6 = 00: 50% current (minimum linearity); 01: 63% current; 10: 78% current; 11: 100% current (maximum linearity).
D6	0	
D5	0	Set to 0
D4	0	
D3	0	Tx Upconverter Linearity. D3: D2 = 00: 50% current (minimum linearity); 01: 63% current; 10: 78% current; 11: 100% current (maximum linearity).
D2	0	
D1	0	Tx Baseband Gain. D1:D0 = 00: max baseband gain - 5dB; 01: max baseband gain -3dB; 10: max baseband gain -1.5dB; 11: max baseband gain.
D0	0	

2.4GHz/5GHz、单频和双频、 802.11g/a RF收发器芯片

表 15. PA 偏置 DAC 寄存器 (A3:A0 = 1010)

DATA BIT	DEFAULT	DESCRIPTION	
D13	0	Set to 0	
D12	0		
D11	0		
D10	0		
D9	1	Sets PA bias DAC turn-on delay after TXENA is set high, in steps of 0.5 μ s. D9:D6 = 0001 corresponds to 0 μ s, and 1111 corresponds to 7 μ s.	
D8	1		
D7	1		
D6	1		
D5	0	Sets PA bias DAC output current in steps of 5 μ A. D5:D0 = 000000 corresponds to 0 μ A, and 111111 corresponds to 315 μ A.	
D4	0		
D3	0		
D2	0		
D1	0		
D0	0		

表 16. Rx 增益寄存器 (A3:A0 = 1011)

DATA BIT	DEFAULT	DESCRIPTION	
D13	0	Not Used. For faster Rx gain setting, only D6:D0 need to be programmed.	
D12	0		
D11	0		
D10	0		
D9	0		
D8	0		
D7	0		
D6	1	Rx LNA Gain Control	Rx baseband and RF gain-control bits. D6 maps to digital input pin B7, and D0 maps to digital input pin B1. D6:D0 = 0000000 corresponds to minimum gain.
D5	1		
D4	1	Rx VGA Gain Control	
D3	1		
D2	1		
D1	1		
D0	1		

2.4GHz/5GHz、单频和双频、 802.11g/a RF收发器芯片

MAX2825/MAX2826/MAX2827

应用信息

Rx通路

LNA输入匹配

使用高Q值元件将LNA输入匹配到50Ω，LNA的输入要求交流耦合。典型工作电路中的元件值可作为起始值。也可以利用MAX2825/MAX2826/MAX2827评估(EV)板数据资料中的电路。

Rx基带放大器输出

差分I/Q RF基带放大器输出由内部偏置到0.96V。可以驱动负载高达10kΩ || 8pF。在大多数应用中，输出可直接连接到基带IC的ADC输入。正确的电路板布局对保持I/Q通道之间的良好平衡非常重要，可提供良好的正交相位精度。

Rx增益控制

接收器增益可通过输入引脚B1至B7设置，或通过内部Rx增益寄存器设置。典型工作特性中给出了增益控制特性。

RSSI

RSSI输出可配置为两种输出电压范围：0.5V至2V或0.5V至2.5V(见表13a)。RSSI输出不受Rx VGA增益设置的影响。RSSI输出可驱动负载达10kΩ || 5pF。典型工作特性中给出了RSSI输出特性。

Tx通路

Tx基带输入

差分I/Q输入设计能够适应0.9V至1.3V的输入共模电压(来自基带IC的DAC输出)。I/Q输入由100mV_{RMS}差分OFDM基带信号驱动。每对Tx基带输入看进去的差分阻抗为60kΩ || 0.5pF。正确的电路板布局对保持I/Q通道之间的良好平衡非常重要，可提供良好的正交相位精度。

PA驱动器

功放驱动器的差分RF输出需要外部阻抗匹配到50Ω。差分RF输出要求交流耦合。差分到单端的转换可使用外部非平衡变压器实现。在典型工作电路中，非平衡变压器、电感和电容构成了PA驱动器输出的匹配网络。正确的电路板布局对保持差分输出之间的良好平衡非常重要。欲获得详细信息，请参考MAX2825/MAX2826/MAX2827评估板数据手册。

表 17. 发送器 VGA 增益寄存器 (A3:A0 = 1100)

DATA BIT	DEFAULT	DESCRIPTION
D13	0	Not Used. For faster Tx VGA gain setting, only D5:D0 need to be programmed.
D12	0	
D11	0	
D10	0	
D9	0	
D8	0	
D7	0	
D6	0	
D5	0	
D4	0	
D3	0	
D2	0	
D1	0	
D0	0	

2.4GHz/5GHz、单频和双频、802.11g/a RF收发器芯片

Tx VGA 增益控制

Tx 增益可通过数字输入引脚 B1 至 B6 设置，或通过内部 Tx VGA 增益寄存器设置。也可以调节 Tx 模块的线性度(表 14)。典型工作特性中给出了 Tx VGA 的增益控制特性。

PA 偏置 DAC

PA 偏置引脚提供模拟电流输出。将 PABIAS 直接连接到外部 PA 的偏置电流引脚。

环路滤波器

PLL 采用经典的电荷泵，带有外部环路滤波器，连接到 VCO 电压调谐输入。环路滤波器的拓扑结构和元件值可在 MAX2825/MAX2826/MAX2827 评估板数据手册中找到。设置电容值和电阻值，以提供合适的环路带宽，从而达到需要的锁定时间，同时保持环路稳定性。推荐使用 140kHz 的环路带宽以保证在 Tx/Rx 切换时快速建立环路。

布局问题

可将 MAX2825/MAX2826/MAX2827 评估板作为布局的起点。为获得最佳性能，应考虑接地和 RF、基带、电源的布线问题。过孔到地平面的连线尽可能短。在高阻端口，需要确保较短的引线，以减小并联电容。可在 www.maxim-ic.com.cn 网站上申请评估板 Gerber 文件。

电源布局

为减小芯片不同部分之间的耦合，建议使用星型电源配置，V_{CC} 中心节点使用大容值的去耦电容。V_{CC} 连线从这个节点引出，每条线到独立的 V_{CC} 节点。旁路电容尽可能靠近每个电源引脚。这样的安排为每个 V_{CC} 提供本地去耦。为获得低寄生电感的接地连接，每个旁路电容至少使用一个过孔。旁路电容的接地过孔不能与其它支路共用。

匹配网络布局

匹配网络的布局对电路寄生参数非常敏感。为减小寄生电感，应保证所有走线尽可能短，元件尽可能靠近 IC 放置。

2.4GHz/5GHz、单频和双频、 802.11g/a RF收发器芯片

功能框图

MAX2825/MAX2826/MAX2827

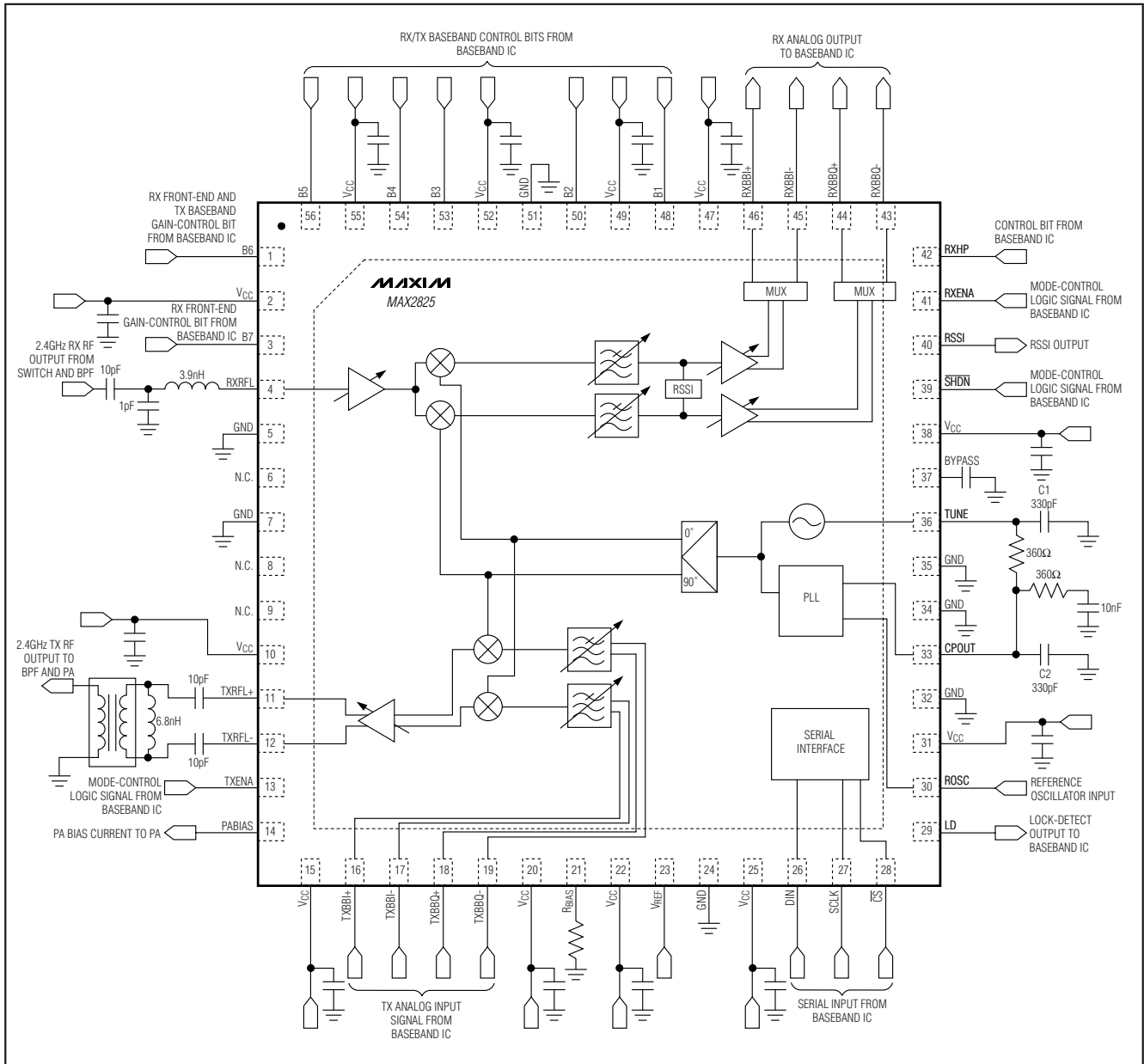

2.4GHz/5GHz、单频和双频、 802.11g/a RF收发器芯片

功能框图 (续)

MAX2825/MAX2826/MAX2827

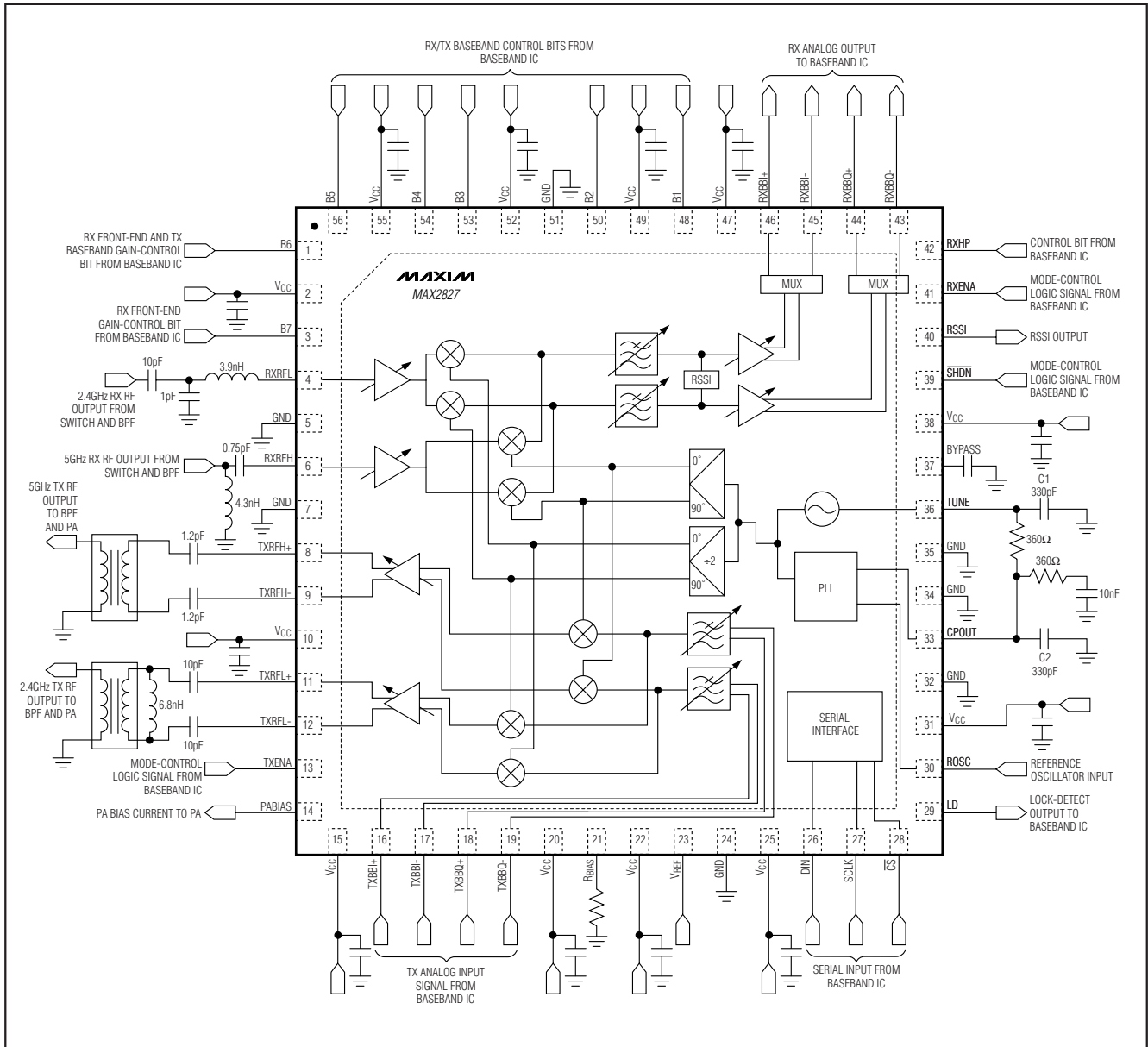

2.4GHz/5GHz、单频和双频、802.11g/a RF收发器芯片

引脚配置 (续)

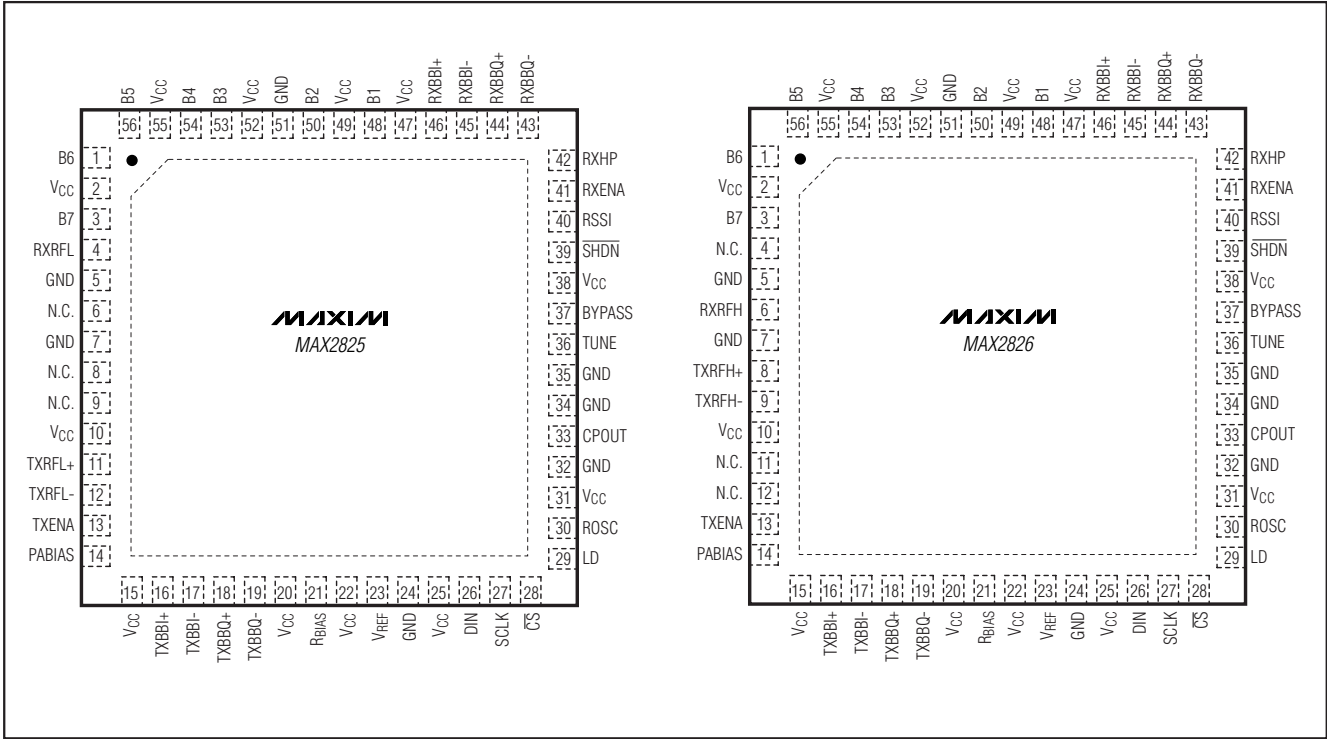

芯片信息

MAX2825 TRANSISTOR COUNT: 47,835
 MAX2826 TRANSISTOR COUNT: 47,835
 MAX2827 TRANSISTOR COUNT: 47,835

2.4GHz/5GHz、单频和双频、 802.11g/a RF收发器芯片

封装信息

(本数据资料提供的封装图可能不是最近的规格，如需最近的封装外型信息，请查询 www.maxim-ic.com.cn/packages。)

MAX2825/MAX2826/MAX2827

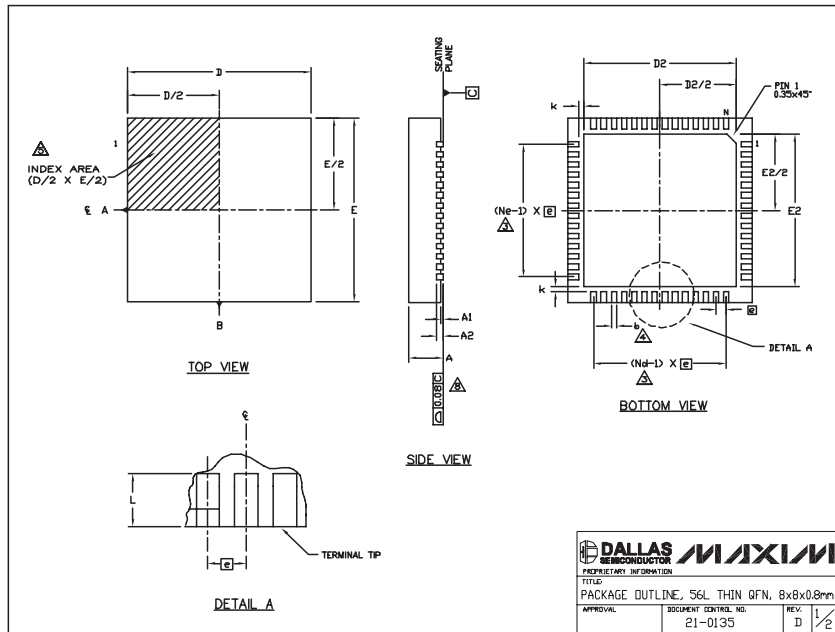

NOTES:

- DIE THICKNESS ALLOWABLE IS 0.225mm MAXIMUM (0.009 INCHES MAXIMUM).
- DIMENSIONING & TOLERANCES CONFORM TO ASME Y14.5M, - 1994.
- N IS THE NUMBER OF TERMINALS.
Nd IS THE NUMBER OF TERMINALS IN X-DIRECTION &
Ne IS THE NUMBER OF TERMINALS IN Y-DIRECTION.
- DIMENSION b APPLIES TO PLATED TERMINAL AND IS MEASURED BETWEEN 0.20 AND 0.25mm FROM TERMINAL TIP.
- THE PIN #1 IDENTIFIER MUST BE LOCATED ON THE TOP SURFACE OF THE PACKAGE WITHIN HATCHED AREA AS SHOWN. EITHER AN INDENTATION MARK OR INK/LASER MARK IS ACCEPTABLE.
- ALL DIMENSIONS ARE IN MILLIMETERS.
- PACKAGE WARPAGE MAX 0.01mm.
- APPLIES TO EXPOSED PAD AND TERMINALS. EXCLUDES INTERNAL DIMENSION OF EXPOSED PAD.
- MEETS JEDEC MO220.

56L 8x8			
	MIN.	NOM.	MAX.
A	0.70	0.75	0.80
b	0.20	0.25	0.30
D	7.90	8.00	8.10
E	7.90	8.00	8.10
	0.50 BSC		
N	56		
Nd	14		
Ne	14		
L	0.30	0.40	0.50
A1	0.00	0.02	0.05
A2	0.20 REF		
k	0.25	--	--

PKG. CODE	EXPOSED PAD VARIATION						JEDEC	DOWN BONDS ALLOWED
	D2			E2				
	MIN.	NOM.	MAX.	MIN.	NOM.	MAX.		
TS688-1	6.50	6.65	6.70	6.50	6.65	6.70	WLLD-5	NO
TS688-2	6.50	6.65	6.70	6.50	6.65	6.70	WLLD-5	YES
TS688-3	6.50	6.65	6.70	6.50	6.65	6.70	WLLD-5	NO

DALLAS SEMICONDUCTOR		MAXIM	
REGISTRY INFORMATION			
TITLE			
PACKAGE OUTLINE, 56L THIN QFN, 8x8x0.8mm			
APPROVAL	DOCUMENT CONTROL NO.	REV.	
	21-0135	D	2/2

Maxim 不对 Maxim 产品以外的任何电路使用负责，也不提供其专利许可。Maxim 保留在任何时间、没有任何通报的前提下修改产品资料和规格的权利。

Maxim Integrated Products, 120 San Gabriel Drive, Sunnyvale, CA 94086 (408) 737-7600 41