

AT Commands for Central Site Modems

Reference Manual (Preliminary)

AT Commands for Central Site Modems Reference Manual

NOTICE

Information furnished by Rockwell International Corporation is believed to be accurate and reliable. However, no responsibility is assumed by Rockwell International for its use, nor any infringement of patents or other rights of third parties which may result from its use. No license is granted by implication or otherwise under any patent rights of Rockwell International other than for circuitry embodied in Rockwell products. Rockwell International reserves the right to change circuitry at any time without notice. This document is subject to change without notice.

K56flex is a trademark of Lucent Technologies and Rockwell International.
MNP is a registered trademark of Microcom, Inc.
Hayes is a registered trademark of Hayes Microcomputer Products, Inc.

AT Commands for Central Site Modems Reference Manual

Table of Contents

1. INTRODUCTION	1-1
1.1 OVERVIEW.....	1-1
1.1.1 Command Syntax.....	1-1
1.1.2 Command Descriptions.....	1-1
1.1.3 Call Progress and Blacklisting Parameters.....	1-1
1.1.4 ConfigurACE II for Windows Utility Program.....	1-1
1.2 REFERENCE DOCUMENTATION.....	1-2
2. COMMAND SYNTAX	2-1
2.1 DTE/DCE INTERCHANGE CIRCUITS.....	2-1
2.2 COMMAND SYNTAX AND GUIDELINES.....	2-1
2.2.1 DTE Commands.....	2-1
2.2.2 DTE Command Lines.....	2-1
2.3 AT COMMAND GUIDELINES.....	2-1
2.3.1 Basic Command Syntax.....	2-1
2.3.2 Extended Command Syntax.....	2-1
3. AT COMMAND SET	3-1
3.1 AT COMMAND GUIDELINES.....	3-1
3.1.1 AT Commands, DTE Adaption.....	3-1
3.1.2 AT Command Format.....	3-1
3.1.3 Escape Code Sequence.....	3-1
3.2 AT COMMAND SET.....	3-2
3.2.1 AT Commands.....	3-2
A/ - Re-execute Command.....	3-2
AT= x - Write to Selected S-Register.....	3-2
AT? - Read Selected S-Register.....	3-2
A - Answer.....	3-2
Bn - CCITT or Bell.....	3-2
Cn - Carrier Control.....	3-3
Dn - Dial.....	3-3
En - Command Echo.....	3-4
Hn - Disconnect (Hang-Up).....	3-5
In - Identification.....	3-5
Ln - Speaker Volume.....	3-5
Mn - Speaker Control.....	3-6
Nn - Automode Enable.....	3-6
On - Return to On-Line Data Mode.....	3-6
P - Set Pulse Dial Default.....	3-7
Qn - Quiet Results Codes Control.....	3-7
Sn - Select S-Register.....	3-7
T - Set Tone Dial Default.....	3-8
Vn - Result Code Form.....	3-8
Wn - Connect Message Control.....	3-8
Xn - Extended Result Codes.....	3-9
Yn - Long Space Disconnect.....	3-12
Zn - Soft Reset and Restore Profile.....	3-12
3.2.2 AT& Commands.....	3-13
&Cn - RLSD (DCD) Option.....	3-13
&Dn - DTR Option.....	3-13
&Fn - Restore Factory Configuration (Profile).....	3-13
&Gn - Select Guard Tone.....	3-14
&Jn - Telephone Jack Control.....	3-14

AT Commands for Central Site Modems Reference Manual

&Kn - Flow Control	3-14
&Ln - Leased Line Operation	3-14
&Mn - Asynchronous/Synchronous Mode Selection	3-15
&Pn - Select Pulse Dial Make/Break Ratio	3-15
&Qn - Sync/Async Mode.....	3-16
&Rn - RTS/CTS Option.....	3-16
&Sn - DSR Override	3-17
&Tn - Test and Diagnostics.....	3-17
&V - Display Current Configuration and Stored Profiles	3-18
3.2.3 &V1 - Display Last Connection Statistics	3-19
&Wn - Store Current Configuration	3-20
&Xn - Select Synchronous Clock Source.....	3-20
&Yn - Designate a Default Reset Profile.....	3-20
&Zn=x - Store Telephone Number	3-20
3.2.4 AT% Commands	3-21
%En - Enable/Disable Line Quality Monitor and Auto-Retrain or Fallback/Fall Forward	3-21
%L - Line Signal Level.....	3-21
%Q - Line Signal Quality.....	3-21
%7 - Plug and Play Serial Number	3-22
%8 - Plug and Play Vendor ID and Product Number.....	3-22
3.2.5 AT\ Commands	3-23
\Kn - Break Control.....	3-23
\Nn - Operating Mode.....	3-24
\Vn - Single Line Connect Message Enable.....	3-25
3.2.6 AT+ Commands	3-26
+MS - Select Modulation.....	3-26
3.2.7 AT** Command	3-29
** - Download to SRAM	3-29
3.2.8 AT- Commands	3-29
-SDR=n - Enable/Disable Distinctive Ring	3-29
3.3 ERROR DETECTION AND DATA COMPRESSION COMMANDS.....	3-31
3.3.1 AT% Commands	3-31
%C - Enable/Disable Data Compression	3-31
3.3.2 AT\ Commands	3-31
\An - Select Maximum MNP Block Size.....	3-31
\Bn - Transmit Break to Remote.....	3-31
3.4 MNP 10 COMMANDS.....	3-32
3.4.1 AT) Commands	3-32
)Mn - Enable Cellular Power Level Adjustment.....	3-32
*Hn - Link Negotiation Speed.....	3-32
-Kn - MNP Extended Services	3-32
-Qn - Enable Fallback to V.22 bis/V.22.....	3-32
-SEC=n - Enable/Disable MNP10-EC.....	3-33
@Mn - Initial Cellular Power Level Setting.....	3-33
:E - Compromise Equalizer Enable Command.....	3-33
3.5 W-CLASS COMMANDS.....	3-34
3.5.1 AT* Commands	3-34
*B - Display Blacklisted Numbers	3-34
*D - Display Delayed Numbers.....	3-34
*NCn - Country Select	3-35
3.6 AT COMMAND RESULT CODES	3-36
OK (0)	3-36
CONNECT (1)	3-36
RING (2)	3-36
NO CARRIER (3).....	3-36
ERROR (4).....	3-36
CONNECT 1200 (5).....	3-36

AT Commands for Central Site Modems Reference Manual

NO DIALTONE (6).....	3-36
BUSY (7).....	3-37
NO ANSWER (8).....	3-37
CONNECT 0600 (9).....	3-37
CONNECT 2400 (10).....	3-37
CONNECT 4800 (11).....	3-37
CONNECT 9600 (12).....	3-37
CONNECT 7200 (13).....	3-37
CONNECT 12000 (14).....	3-37
CONNECT 14400 (15).....	3-37
CONNECT 19200 (16).....	3-37
CONNECT 38400 (17).....	3-38
CONNECT 57600 (18).....	3-38
CONNECT 115200 (19).....	3-38
CONNECT 75TX/1200RX (22).....	3-38
CONNECT 1200TX/75RX (23).....	3-38
DELAYED (24).....	3-38
BLACKLISTED (32).....	3-38
FAX (33).....	3-38
DATA (35).....	3-38
CARRIER 300 (40).....	3-38
CARRIER 1200/75 (44).....	3-38
CARRIER 75/1200 (45).....	3-38
CARRIER 1200 (46).....	3-38
CARRIER 2400 (47).....	3-38
CARRIER 4800 (48).....	3-38
CARRIER 7200 (49).....	3-39
CARRIER 9600 (50).....	3-39
CARRIER 12000 (51).....	3-39
CARRIER 14400 (52).....	3-39
CARRIER 16800 (53).....	3-39
CARRIER 19200 (54).....	3-39
CARRIER 21600 (55).....	3-39
CARRIER 24000 (56).....	3-39
CARRIER 26400 (57).....	3-39
CARRIER 28800 (58).....	3-39
CONNECT 16800 (59).....	3-39
CONNECT 21600 (61).....	3-39
CONNECT 24000 (62).....	3-39
CONNECT 26400 (63).....	3-39
CONNECT 28800 (64).....	3-40
COMPRESSION: CLASS 5 (66).....	3-40
COMPRESSION: V.42 bis (67).....	3-40
COMPRESSION: NONE (69).....	3-40
PROTOCOL: NONE (70).....	3-40
PROTOCOL: LAPM (77).....	3-40
CARRIER 31200 (78).....	3-40
CARRIER 33600 (79).....	3-40
PROTOCOL: ALT (80).....	3-40
PROTOCOL: ALT-CELLULAR (81).....	3-40
CONNECT 33600 (84).....	3-40
CONNECT 31200 (91).....	3-40
CARRIER 32000 (150).....	3-40
CARRIER 34000 (151).....	3-40
CARRIER 36000 (152).....	3-41
CARRIER 38000 (153).....	3-41
CARRIER 40000 (154).....	3-41
CARRIER 42000 (155).....	3-41
CARRIER 44000 (156).....	3-41
CARRIER 46000 (157).....	3-41

AT Commands for Central Site Modems Reference Manual

CARRIER 48000 (158)	3-41
CARRIER 50000 (159)	3-41
CARRIER 52000 (160)	3-41
CARRIER 54000 (161)	3-41
CARRIER 56000 (162)	3-41
CONNECT 32000 (165)	3-41
CONNECT 34000 (166)	3-41
CONNECT 36000 (167)	3-41
CONNECT 38000 (168)	3-42
CONNECT 40000 (169)	3-42
CONNECT 42000 (170)	3-42
CONNECT 44000 (171)	3-42
CONNECT 46000 (172)	3-42
CONNECT 48000 (173)	3-42
CONNECT 50000 (174)	3-42
CONNECT 52000 (175)	3-42
CONNECT 54000 (176)	3-42
CONNECT 56000 (177)	3-42
CONNECT 230400 (20)	3-42
+FCERROR (+F4)	3-42
3.7 CSM UNIQUE COMMANDS	3-43
3.7.1 +ISP Command - Select Pass-Through Mode or POTS Modem Connection.....	3-43
3.7.2 +ES Command - Select Frame Tunneling Mode.....	3-43
3.7.3 #CID Command - Multi-Frequency (MF) Tone Detection	3-43
3.7.4 ISDN PPP Connection Support	3-45
Frame Tunneling Support (Async-HDLC) per RFC 1662 for ISDN PPP Connections	3-45
Sending HDLC Frames.....	3-45
Receiving HDLC Frames	3-45
3.7.5 +TSA Command - Program the Time Slot Assignment	3-45
3.7.6 &V2 - Modem Status Reporting.....	3-46
3.7.7 S202 - CSM Bit Mapped Control Register	3-54
4. S-REGISTERS	4-1
4.1 FACTORY DEFAULTS	4-1
4.2 S-REGISTER DEFINITIONS.....	4-4
S0 - Number of Rings to Auto-Answer	4-4
S1 - Ring Counter.....	4-4
S2 - Escape Character	4-4
S3 - Carriage Return Character	4-4
S4 - Line Feed Character.....	4-4
S5 - Backspace Character	4-4
S6 - Wait Time for Dial Tone Before Blind Dialing, or After "W" Dial Modifier (W-Class Models)	4-5
S7 - Wait Time For Carrier After Dial, For Silence, or For Dial Tone After "W" Dial Modifier (US Models).....	4-5
S8 - Pause Time For Dial Delay	4-5
S9 - Carrier Detect Response Time	4-5
S10 - Lost Carrier To Hang Up Delay.....	4-5
S11 - DTMF Tone Duration.....	4-5
S12 - Escape Prompt Delay (EPD)	4-6
S13 - Reserved	4-6
S14 - General Bit Mapped Options Status.....	4-6
S15 - Reserved	4-6
S16 - General Bit Mapped Test Options Status.....	4-7
S17 - Reserved	4-7
S18 - Test Timer.....	4-7
S19 - AutoSync Bit Mapped Options	4-8
S20 - AutoSync HDLC Address or BSC Sync Character.....	4-8
S21 - V.24/General Bit Mapped Options Status.....	4-9
S22 - Speaker/Results Bit Mapped Options Status.....	4-10

AT Commands for Central Site Modems Reference Manual

S23 - General Bit Mapped Options Status.....	4-11
S24 - Sleep Inactivity Timer	4-11
S25 - Delay To DTR	4-11
S26 - RTS to CTS Delay	4-11
S27 - Bit Mapped Options Status	4-12
S28 - Bit Mapped Options Status	4-13
S29 - Flash Dial Modifier Time	4-13
S30 - Disconnect Inactivity Timer	4-13
S31 - Bit Mapped Options Status	4-14
S32 - XON Character	4-14
S33 - XOFF Character	4-14
S34-S35 - Reserved	4-14
S36 - LAPM Failure Control	4-15
S37 - Desired Line Connection Speed.....	4-16
S38 - Delay Before Forced Hang Up.....	4-17
S39 - Flow Control Bit Mapped Options Status.....	4-17
S40 - General Bit Mapped Options Status.....	4-18
S41 - General Bit Mapped Options Status.....	4-19
S46 - Data Compression Control	4-19
S48 - V.42 Negotiation Action	4-19
S82 - Break Handling Options.....	4-20
S86 - Call Failure Reason Code.....	4-20
S91 - PSTN Transmit Attenuation Level.....	4-20
S92 - Fax Transmit Attenuation Level	4-20
S95 - Extended Result Codes	4-21
5. FAX CLASS 1 COMMANDS	5-1
5.1 FAX I/O PROCESSING	5-1
5.1.1 DTE-to-Modem Transmit Data Stream.....	5-1
5.1.2 Modem-to-DTE Receive Data Stream.....	5-1
5.1.3 Fax Mode Selection	5-1
5.1.4 Fax Origination	5-1
5.1.5 Fax Answering.....	5-2
5.1.6 Fax Control Transmission	5-2
5.1.7 Fax Control Reception	5-2
5.1.8 Fax Data Transmission	5-3
5.1.9 Fax Data Reception	5-3
5.2 COMMANDS	5-4
+FCCLASS=n - Select Service Class	5-4
+F<command>? - Report Active Configuration.....	5-4
+F<command>=? - Report Operating Capabilities.....	5-4
+FAE=n - Data/Fax Auto Answer	5-4
+FTS=n - Stop Transmission and Wait.....	5-4
+FRS=n - Receive Silence.....	5-4
+FTM=n - Transmit Data	5-5
+FRM=n - Receive Data	5-5
+FTH=n - Transmit Data with HDLC Framing.....	5-6
+FRH=n - Receive Data with HDLC Framing.....	5-6
5.3 EXAMPLES	5-6
6. FAX CLASS 2 COMMANDS	6-1
6.1 COMMAND SYNTAX AND GUIDELINES.....	6-1
6.1.1 DTE Commands	6-1
DTE Command Lines	6-1
Facsimile Command Syntax	6-1
6.1.2 Serial Port Speed and Flow Control	6-3
Data Stream Termination.....	6-3
DTE to DCE Streams.....	6-3

AT Commands for Central Site Modems Reference Manual

DCE to DTE Streams.....	6-3
6.1.3 Auto Answer.....	6-3
6.1.4 Identification of T.30 Options.....	6-3
6.1.5 Session Status Reporting.....	6-4
6.1.6 Procedure Interrupt Negotiation.....	6-4
6.2 SERVICE CLASS 2 IDENTIFICATION AND SELECTION.....	6-4
6.2.1 +FMFR?, Request Manufacturer Identification.....	6-4
6.2.2 +FMDL?, Identify Product Model.....	6-4
6.2.3 +FREV?, Identify Product Revision.....	6-4
6.3 SERVICE CLASS 2 ACTION COMMANDS.....	6-4
6.3.1 ATD, Originate a Call.....	6-5
6.3.2 ATA, Answer a Call.....	6-5
Manual Call Answer.....	6-5
Automatic Answer.....	6-5
Connection as a Data Modem.....	6-5
6.3.3 +FDT, Data Transmission.....	6-6
Initiate Page Transmission.....	6-6
Continue a Page.....	6-6
Phase C Data Framing.....	6-6
Phase C Data Format.....	6-6
<CAN>, Escape from Transmission.....	6-6
6.3.4 +FET, Transmit Page Punctuation.....	6-8
End a Page.....	6-8
6.3.5 +FDR, Begin or Continue Phase C Receive Data.....	6-9
Initiate Document Reception.....	6-9
Continue Document Reception.....	6-10
Phase C Data Framing.....	6-10
Phase C Data Format.....	6-10
<CAN>, Escape from Reception.....	6-10
6.3.6 +FK, Session Termination.....	6-10
6.3.7 +FCIG, Set Polling ID.....	6-11
6.3.8 +FLPL, Indicate a Document for Polling.....	6-11
6.3.9 +FSPL, Enable Polling.....	6-11
6.4 SERVICE CLASS 2 DCE RESPONSES.....	6-13
6.4.1 +FCON, Facsimile Connection Response.....	6-13
6.4.2 +FDCS:, Report Current Session Capabilities.....	6-13
6.4.3 +FDIS:, Report Remote Station Capabilities.....	6-13
6.4.4 +FCFR, Indicate Confirmation to Receive.....	6-13
6.4.5 +FTSI:, Report the Transmit Station ID.....	6-13
6.4.6 +FCSI:, Report the Called Station ID.....	6-13
6.4.7 +FPTS:, Receive Page Transfer Status.....	6-14
6.4.8 +FET:, Post Page Message Response.....	6-14
6.4.9 +FPTS:, Transmit Page Transfer Status.....	6-14
6.4.10 +FHNG:, Call Termination with Status.....	6-14
6.4.11 +FCIG:, Report the Polled Station ID.....	6-15
6.4.12 +FDTC:, Report the Polled Station Capabilities.....	6-15
6.4.13 +FPOLL, Indicate Polling Request.....	6-15
6.5 SERVICE CLASS 2 PARAMETERS.....	6-16
6.5.1 +FDCC, DCE Capabilities Parameters.....	6-17
6.5.2 +FDIS, Current Sessions Capabilities Parameters.....	6-17
6.5.3 +FDCCS, Current Session Results Parameters.....	6-18
6.5.4 +FLID=, Local ID String.....	6-19
6.5.5 +FCR, Capability to Receive.....	6-19

AT Commands for Central Site Modems Reference Manual

6.5.6 +FPTS=, Page Transfer Status	6-19
6.5.7 +FCQ, Copy Quality Checking	6-19
6.5.8 +FPHCTO, DTE Phase C Response Time-out	6-19
6.5.9 +FAXERR, T.30 Session Error Report	6-20
6.5.10 +FBOR, Data Bit Order	6-20
6.5.11 +FAA, Answer Parameter	6-20
6.5.12 +FBUF?, Buffer Size	6-21
6.6 EXAMPLE SESSIONS	6-21
7. AT COMMAND SET SUMMARY	7-1
7.1 BASIC AT COMMANDS	7-1
7.2 ECC COMMANDS	7-4
7.3 MNP 10 COMMANDS	7-5
7.4 W-CLASS COMMANDS	7-5
7.5 CALLER ID COMMANDS	7-5
7.6 FAX CLASS 1	7-5
7.7 FAX CLASS 2	7-6
7.8 SYNCHRONOUS ACCESS MODE COMMANDS	7-7
7.9 CSM UNIQUE COMMANDS	7-7
8. COMMON CONFIGURATION SETUP STRINGS	8-1

AT Commands for Central Site Modems Reference Manual

List of Tables

Table 3-1. Result Codes	3-10
Table 3-2. Received Multi-Frequency (MF) Tone Code	3-44
Table 4-1. S-Register Summary.....	4-2
Table 5-1. Fax Class 1 Commands	5-1
Table 5-2. Fax Class 1 Calling Sequence (One Page).....	5-7
Table 5-3. Fax Class 1 Answering Sequence (One Page)	5-8
Table 6-1. Fax Class 2 Commands	6-2
Table 6-2. T.30 Session Subparameter Codes.....	6-7
Table 6-3. T.30 Post Page Message Codes	6-8
Table 6-4. T.30 Post Page Response Messages.....	6-8
Table 6-5. Hang Up Status Codes	6-12
Table 6-6. Send Two Pages, 1-D, No Errors	6-22
Table 6-7. Receive Two Pages, 1-D Data, No Errors.....	6-23

List of Figures

Figure 6-1. T.30 Session Parameter Relationships.....	6-17
---	------

1. INTRODUCTION

1.1 OVERVIEW

This manual describes the AT commands for the following Rockwell central site modem families:

RL56CSM/3
RS56CSM/2 and RSCSM
RC56CSM/2 and RC56CSM
RC336CSM/2 and RC336CSM

NOTE:

1. **AT commands that operate identical or similar to corresponding client modem commands are described in Sections 3.2 through Section 3.7. Any differences in CSM operation are noted in these sections.**
2. **S registers that operate identical or similar to corresponding client modem commands are described in Section 4. Any differences in CSM operation are noted in this section.**
3. **Unique client modem commands and S registers are described in Section 3.7.**
4. **AT Command and S register descriptions apply to all CSM modems except as noted.**

1.1.1 Command Syntax

The fundamental DTE interface command syntax is described in Section 2.

1.1.2 Command Descriptions

These commands are grouped into the following categories:

AT commands	Section 3
S-Registers	Section 4
Fax Class 1 commands	Section 5
Fax Class 2 commands	Section 6
AT Command Summary	Section 7

The AT commands are implemented in microcontroller (MCU) firmware for specific modem models.

1.1.3 Call Progress and Blacklisting Parameters

The modem MCU firmware can be configured for operation in specific countries by the PC-compatible ConfigurACE II program. The call progress and blacklisting parameters described in the ConfigurACE II User's Manual can be altered and loaded for a number of countries by this program.

1.1.4 ConfigurACE II for Windows Utility Program

The PC-based ConfigurACE II for Windows utility program allows the OEM to customize the modem firmware to suit specific application and country requirements. ConfigurACE II for Windows allows programming of functions such as:

- Loading of multiple sets of country parameters
- Loading of NVRAM factory profiles
- Call progress and blacklisting parameters
- Entry of S register maximum/minimum values
- Limitation of transmit levels
- Modification of factory default values
- Customization of the ATI4 response
- Customization of fax OEM messages

AT Commands for Central Site Modems Reference Manual

This program modifies the hex object code which can be programmed directly into the system SRAM. Lists of the generated parameters can be displayed or printed. Rockwell-provided country parameter files allow a complete set of country-specific call progress and blacklisting parameters to be selected.

Refer to the ConfigurACE II for Windows software for a detailed description of capabilities and the operating procedure.

1.2 REFERENCE DOCUMENTATION

RL56CSM/3 Downloadable Modem Device Designer's Guide (Order No. 1137)

RS56CSM Modem Device Set Designer's Guide (Order No. 1142)

RC56CSM and RC336CSM Modem Device Set Designer's Guide (Order No. 1127)

2. COMMAND SYNTAX

2.1 DTE/DCE INTERCHANGE CIRCUITS

Communication between the DTE and modem (DCE) follows command-response protocol, i.e., the DTE sends a command to the modem, then waits for a response from the modem.

2.2 COMMAND SYNTAX AND GUIDELINES

2.2.1 DTE Commands

The ISO 646 character set (CCITT T.50 International Alphabet 5, American Standard Code for Information Interchange) is used for the issuance of commands and responses. Only the low-order 7 bits of each character are used for commands or parameters; the high-order bit is ignored. Upper case characters are equivalent to lower case characters.

2.2.2 DTE Command Lines

A command line is a string of characters sent from a DTE to the DCE while the DCE is in a command state. Command lines have a prefix, a body, and a terminator. The prefix consists of the ASCII characters "AT" (065, 084) or "at" (097, 116). The body is a string of commands restricted to printable ASCII characters (032 - 126). Space characters (ASCII 032) and control characters other than carriage return <CR> (default value = ASCII 013 = 0Dh, see register S3), backspace <BS> (default value = ASCII 008 = 08h, see register S5), and cancel <cntrl-x> (ASCII 024 = 18h) in the command string are ignored. The default terminator is the <CR> character. Characters that precede the AT prefix are ignored.

2.3 AT COMMAND GUIDELINES

Modem operation is controlled by generic AT commands. These AT commands may be basic AT (i.e., commands preceded by AT, AT&, AT%, AT*, AT\, AT), AT-, or AT#), S-Register (e.g., S6=n), Fax class 1 (e.g., +FTM), or Fax class 2 (e.g., +FDCS:) commands. The command syntax and operation guidelines governing each of these command categories are described in subsequent sections.

2.3.1 Basic Command Syntax

Characters within the command line are parsed as commands with associated parameter values. The basic commands consist of single ASCII characters, or single characters preceded by a prefix character, followed by a decimal parameter (e.g., "&D1"). Missing decimal parameters are evaluated as 0.

2.3.2 Extended Command Syntax

The facsimile commands use extended syntax. They are preceded by the "+F" characters, and they are terminated by the semicolon ":" character (ASCII 059) or by the <CR> that terminates the command line.

AT Commands for Central Site Modems Reference Manual

This page is intentionally blank.

3. AT COMMAND SET

3.1 AT COMMAND GUIDELINES

The basic AT commands used to control modem operation are defined in this section. These commands are summarized in Appendix A. All commands may not be available in a specific product depending upon supported data rates and modes. The default values are typical of a fully configured modem supporting all data rates and options. The actual default value is dependent upon modem firmware as defined by the firmware release notes.

3.1.1 AT Commands, DTE Adaption

Under AT operation, the serial interfaced modem performs an autobaud/autoparity/autolength function on each AT header entered. The autolength/autoparity facility can detect 7- or 8-bit characters of even, odd, or no parity with one stop bit. This is not necessary for the parallel interfaced modem since it has direct access to the UART registers.

3.1.2 AT Command Format

A command line is a string of characters sent from a DTE to the modem (DCE) while the modem is in a command state. A command line has a prefix, a body, and a terminator. Each command line (with the exception of the A/ command) must begin with the character sequence AT and must be terminated by a carriage return. Commands entered in upper case or lower case are accepted, but both the A and T must be of the same case, i.e., "AT" = ASCII 065, 084 or "at" = ASCII 097, 116. The body is a string of commands restricted to printable ASCII characters (032 - 126). Space characters (ASCII 032) and control characters other than CR (ASCII 013) and BS (ASCII 010) in the command string are ignored. The default terminator is the ASCII <CR> character. Characters that precede the AT prefix are ignored. The command line interpretation begins upon receipt of the carriage return character.

Characters within the command line are parsed as commands with associated parameter values. The basic commands consist of single ASCII characters, or single characters preceded by a prefix character (e.g., "&"), followed by a decimal parameter. Missing decimal parameters are evaluated as 0.

The modem supports the editing of command lines by recognizing a backspace character. When modem echo is enabled, the modem responds to receipt of a backspace or delete by echoing a backspace character, a space character, and another backspace. The hex value to be used for the backspace character is programmable through register S5. Values equal to 0 or greater than 127, or the value which corresponds to the carriage return character, cannot be used for the backspace character. This editing is not applicable to the AT header of a command. A command line may be aborted at any time by entering < cntrl-x > (18h).

The AT sequence may be followed by any number of commands in sequence, except for commands such as Z, D, or A. Commands following commands Z, D, or A on the same command line will be ignored. The maximum number of characters on any command line is 60 (including "A" and "T"). If a syntax error is found anywhere in a command line command, the remainder of the line will be ignored and the ERROR result code will be returned.

Most commands entered with parameters out of range will not be accepted and the ERROR response will be returned to the DTE.

Commands will only be accepted by the modem once the previous command has been fully executed, which is normally indicated by the return of an appropriate result code. Execution of commands D and A, either as a result of a direct command or a re-execute command, will be aborted if another character is entered before completion of the handshake.

3.1.3 Escape Code Sequence

When the modem has established a connection and has entered on-line data mode, it is possible to break into the data transmission in order to issue further commands to the modem in an on-line command mode. This is achieved by the DTE sending to the modem a sequence of three ASCII characters specified by register S2. The default character is '+'. The maximum time allowed between receipt of the last character of the three escape character sequence from the DTE and sending of the OK result code to the DTE is controlled by the S12 register.

AT Commands for Central Site Modems Reference Manual

3.2 AT COMMAND SET

The modem will respond to the commands detailed below. Parameters applicable to each command are listed with the command description. The defaults shown for each configuration command are those used in the Rockwell factory profile 0.

3.2.1 AT Commands

A/ - Re-execute Command

The modem behaves as though the last command line had been re-sent by the DTE. "A/" will repeat all the commands in the command buffer.

The principal application of this command is to place another call (using the Dial command) that failed to connect due to a busy line, no answer, or a wrong number. This command must appear alone on a command line. This command should not be terminated by a carriage return.

AT= x - Write to Selected S-Register

This command writes the value x to the currently selected S-Register. An S-Register can be selected by using the ATSn command. All of the S-Registers will return the OK response if x is a number. Some registers may not be written due to country specific PTT limitations.

Result Codes

OK For all arguments.

AT? - Read Selected S-Register

This command reads and displays the selected S-Register. An S-Register can be selected by using the ATSn command.

Result Codes:

OK For all arguments.

A - Answer

The modem will go off-hook and attempt to answer an incoming call if correct conditions are met. Upon successful completion of answer handshake, the modem will go on-line in answer mode. This command may be affected by the state of Line Current Sense, if enabled. (Most countries do not require Line Current Sense.) Operation is also dependent upon +FCLASS command and country-specific requirements.

If +FCLASS=0 is selected, the modem will enter the connect state after exchanging carrier with the remote modem. If no carrier is detected within a period specified in register S7, the modem hangs up. Any character entered during the connect sequence will abort the connection attempt.

If +FCLASS=1 or 2 is selected, the modem will go off-hook in V.21 answer mode. It will generate the V.21 2100 Hz answer tone for 3 ± 0.5 seconds and, following a delay of 70 ms, will proceed as if the +FTH=3 command were issued. At any stage up to (but excluding) the +FTH=3 command state, any character will abort the communication. (See the description of the +FTH command for details.)

Bn - CCITT or Bell

When the modem is configured to allow either option, the modem will select Bell or CCITT modulation for a line speed connection of 300 or 1200 bps according to the parameter supplied. Any other line speed will use a CCITT modulation standard. The parameter value, if valid, is written to S27 bit 6.

B0 Selects CCITT operation at 300 or 1200 bps during Call Establishment and a subsequent connection. (Default for W-class models.)

B1 Selects BELL operation at 300 or 1200 bps during Call Establishment and a subsequent connection. (Default for US models.)

Result Codes:

OK n = 0 or 1.
ERROR Otherwise.

AT Commands for Central Site Modems Reference Manual

Cn - Carrier Control

This command is included for compatibility only, and has no effect other than returning a result code. The only valid parameter is 1.

Result Codes:

OK	n = 1.
ERROR	Otherwise.

Dn - Dial

This command directs the modem to go on-line, dial according to the string entered and attempt to establish a connection. If no dial string is supplied, the modem will go on-line and attempt the handshake in originate mode. In W-class models, the action of going off-hook is affected by the status of the Line Current Sense input, if line current sensing is enabled, and by the blacklist and delayed list. **NOTE:** If the ATD command is issued before the S1 register has cleared, the modem will respond with the NO CARRIER result code.

If +FCLASS=0 is selected, the modem will behave as a data modem and will attempt to connect to another data modem. The modem will have up to the period of time specified by register S6 or S7 to wait for carrier and complete the handshake. If this time expires before the modem can complete the handshake, the modem will go on-hook with the NO CARRIER response. This command will be aborted in progress upon receipt of any DTE character before completion of the handshake.

If +FCLASS=1 or 2 is selected, the modem will behave as a facsimile modem and attempt to connect to a facsimile machine (or modem) by entering the HDLC V.21 channel 2 receive state (as if +FRH=3 had been issued). This command will be aborted upon receipt of any DTE character if the modem has not finished dialing. In this case, the modem will go on-hook and return to command mode after displaying the NO CARRIER message. If the modem has finished dialing, it proceeds as if the +FRH=3 command has been issued. (Refer to the +FRH command to determine how the modem behaves following this stage.)

Dial Modifiers. The valid dial string parameters are described below. Punctuation characters may be used for clarity, with parentheses, hyphen, and spaces being ignored.

0-9	DTMF digits 0 to 9.
*	The 'star' digit (tone dialing only).
#	The 'gate' digit (tone dialing only).
A-D	DTMF digits A, B, C, and D. Some countries may prohibit sending of these digits during dialing.
L	Re-dial last number: the modem will re-dial the last valid telephone number. The L must be immediately after the D with all the following characters ignored).
P	Select pulse dialing: pulse dial the numbers that follow until a "T" is encountered. Affects current and subsequent dialing. Some countries prevent changing dialing modes after the first digit is dialed.
T	Select tone dialing: tone dial the numbers that follow until a "P" is encountered. Affects current and subsequent dialing. Some countries prevent changing dialing modes after the first digit is dialed.
R	This command will be accepted, but not acted on.
S=n	Dial the number stored in the directory (n = 0 to 3). (See &Z.)
!	Flash: the modem will go on-hook for a time defined by the value of S29. Country requirements may limit the time imposed.
W	Wait for dial tone: the modem will wait for dial tone before dialing the digits following "W". If dial tone is not detected within the time specified by S7 (US) or S6 (W-class), the modem will abort the rest of the sequence, return on-hook, and generate an error message.

AT Commands for Central Site Modems Reference Manual

- @ Wait for silence: the modem will wait for at least 5 seconds of silence in the call progress frequency band before continuing with the next dial string parameter. If the modem does not detect these 5 seconds of silence before the expiration of the call abort timer (S7), the modem will terminate the call attempt with a NO ANSWER message. If busy detection is enabled, the modem may terminate the call with the BUSY result code. If answer tone arrives during execution of this parameter, the modem handshakes.
- & Wait for credit card dialing tone before continuing with the dial string. If the tone is not detected within the time specified by S7 (US models) or S6 (W-class models), the modem will abort the rest of the sequence, return on-hook, and generate an error message.
- , Dial pause: the modem will pause for a time specified by S8 before dialing the digits following ",".
- ; Return to command state. Added to the end of a dial string, this causes the modem to return to the command state after it processes the portion of the dial string preceding the ";". This allows the user to issue additional AT commands while remaining off-hook. The additional AT commands may be placed in the original command line following the ";" and/or may be entered on subsequent command lines. The modem will enter call progress only after an additional dial command is issued without the ";" terminator. Use "H" to abort the dial in progress, and go back on-hook.
- ^ Toggles calling tone enable/disable: applicable to current dial attempt only.
- () Ignored: may be used to format the dial string.
- Ignored: may be used to format the dial string.
- <space> Ignored: may be used to format the dial string.
- <i> Invalid character: will be ignored.
- If enabled by country specific parameter, the modem will generate a grounding pulse on the EARTH relay output.

Dial Number Echo (DNE) Feature

CSM firmware supports a feature called Dial Number Echo (DNE). DNE allows the Host controller to capture the Phone Number sent to a modem by a User issuing the ATDTnnnnnnnnnn(cr) command.

With DNE enabled, when the modem receives an ATDTnnnnnnnnnn(cr) command, it will ignore Dialtone, and echo back the phone number in the following format:

(10 DLE characters)(phone number digits)%(number of digits)(10 DLE characters)

Example: ATDT1234567890*#ABCD would echo back as:

```
10h10h10h10h10h10h10h10h10h10h
31h32h33h34h35h36h37h38h39h30h2Ah23h41h42h43h44h26h31h36h
10h10h10h10h10h10h10h10h10h10h
```

DNE is enabled by setting bit 6 in the OEM_STRAP byte in the WF96PROF.ASM file.

ConfigURACE can then be used to create a new S37 file, with DNE enabled.

En - Command Echo

The modem enables or disables the echo of characters to the DTE according to the parameter supplied. The parameter value, if valid, is written to S14 bit 1.

- E0 Disables command echo.
- E1 Enables command echo. (Default.)

Result Codes:

- OK n = 0 or 1.
- ERROR Otherwise.

AT Commands for Central Site Modems Reference Manual

Hn - Disconnect (Hang-Up)

This command initiates a hang up sequence.

This command may not be available for some countries due to PTT restrictions.

- | | |
|----|---|
| H0 | The modem will release the line if the modem is currently on-line, and will terminate any test (AT&T) that is in progress. Country specific, modulation specific, and error correction protocol specific (S38) processing is handled outside of the H0 command. |
| H1 | If on-hook, the modem will go off-hook and enter command mode. For US models, the modem will remain off-hook. For W-class models, the modem will return on-hook after a period of time determined by S7. |

Result Codes:

- | | |
|-------|-------------|
| OK | n = 0 or 1. |
| ERROR | Otherwise. |

In - Identification

The modem reports to the DTE the requested result according to the command parameter.

- | | |
|----|---|
| I0 | Reports product code. Example: 56000 |
| I1 | Calculates the ROM checksum and reports the least significant byte of the checksum in decimal (see firmware release notes). Reports 255 if the prestored checksum value is FFh. |
| I2 | Calculates the ROM checksum and compares it with the prestored checksum. Reports "OK" if the calculated checksum equals the prestored checksum or if the prestored checksum value is FFh; otherwise reports "ERROR". |
| I3 | Reports the firmware version (F), basic model (e.g.,K56), application code (A), and interface type code (I) typically in the form VF.FFF-K56_DPL_CSM. The application codes are: D = Desktop, L = Low Power. The interface type codes are: S = Serial, P = Parallel. Example: V1.100-K56_DLP_CSM. |
| I4 | Reports OEM defined identifier string in either Hayes-compatible binary format (default) or ASCII format (selectable by ConfigurACE). |
| I5 | Reports Country Code parameter. Example: 022 |
| I6 | Reports modem data pump model, internal ROM code revision, and RAM code revision. Example: RC56DDP L8565A Rev 34.0/34.0 |
| I7 | Reports the DAA code resulting from MCU interrogation of the DAA for auto DAA recognition. Example: 000 for US or Canada |

Result Codes:

- | | |
|-------|-------------|
| OK | n = 0 to 7. |
| ERROR | Otherwise. |

Ln - Speaker Volume

The modem sets the speaker volume control according to the parameter supplied. The parameter value, if valid, is written to S22 bits 0 and 1.

- | | |
|----|------------------------|
| L0 | Low volume. |
| L1 | Low volume. (Default.) |
| L2 | Medium volume. |
| L3 | High volume. |

Result Codes:

- | | |
|-------|-------------|
| OK | n = 0 to 3. |
| ERROR | Otherwise. |

AT Commands for Central Site Modems Reference Manual

Mn - Speaker Control

This command selects when the speaker will be on or off. The parameter value, if valid, is written to S22 bits 2 and 3.

M0	Speaker is always off.
M1	Speaker is on during call establishment, but off when receiving carrier. (Default.)
M2	Speaker is always on.
M3	Speaker is off when receiving carrier and during dialing, but on during answering.

Result Codes:

OK	n = 0 to 3.
ERROR	Otherwise.

Nn - Automode Enable

This command enables or disables automode detection. The parameter value, if valid, is written to S31 bit 1.

N0	Automode detection is disabled (equivalent to setting the +MS <automode> subparameter to 0). A subsequent handshake will be conducted according to the contents of S37 or, if S37 is zero, according to the most recently sensed DTE speed.
N1	Automode detection is enabled (equivalent to setting the +MS <automode> subparameter to 1). A subsequent handshake will be conducted according the automode algorithm supported by the modem, e.g., according to the contents of S37 or, if S37 is zero, starting at the highest enabled speed. (Default.)

Result Codes:

OK	n = 0 or 1.
ERROR	Otherwise.

Notes:

1. The Nn and S37=x commands override the +MS command settings. When the N0 or N1 command is issued, the +MS subparameters are updated to reflect the Nn and S37 values (see +MS command and S37 register). For example:

N1S37=10 updates the +MS command subparameters to reflect +MS=10,1,300,12000

N0S37=10 updates the +MS command subparameters to reflect +MS=10,0,12000,12000

2. Use of the +MS command is recommended instead of the Nn and S37=x commands. Nn and S37=x commands are supported for compatibility with existing communication software.

On - Return to On-Line Data Mode

This command determines how the modem will enter the on-line data mode. If the modem is in the on-line command mode, the enters the on-line data mode with or without a retrain. If the modem is in the off-line command mode (no connection), ERROR is reported.

O0	Enters on-line data mode without a retrain. Handling is determined by the Call Establishment task. Generally, if a connection exists, this command connects the DTE back to the remote modem after an escape (+++).
O1	Enters on-line data mode with a retrain before returning to on-line data mode.

Result Codes:

OK	n = 0 or 1 and a connection exists.
ERROR	Otherwise or if not connected.

AT Commands for Central Site Modems Reference Manual

P - Set Pulse Dial Default

This command forces pulse dialing until the next T dial modifier or T command is received. Sets S14 bit 5.

As soon as a dial command is executed which explicitly specifies the dialing mode for that particular call (e.g., ATDT...), this command is overridden so that all future dialing will be tone dialed. (See T command.)

This command may not be permitted in some countries.

Result Code:

OK

Qn - Quiet Results Codes Control

The command enables or disables the sending of result codes to the DTE according to the parameter supplied. The parameter value, if valid, is written to S14 bit 2.

Q0 Enables result codes to the DTE. (Default.)

Q1 Disables result codes to the DTE.

Result Codes:

OK n = 0 or 1.

ERROR Otherwise.

Sn - Select S-Register

The modem selects an S-Register, performs an S-Register read or write function, or reports the value of an S-Register.

n Establishes S-Register n as the last register accessed.

n=v Sets S-Register n to the value v.

n? Reports the value of S-Register n.

The parameter n can be omitted, in which case the last S-Register accessed will be assumed. The S can be omitted for AT= and AT?, in which case the last S-Register accessed will be assumed.

For example:

ATS7 establishes S7 as the last accessed register.

AT=40 sets the contents of the last register accessed to 40.

ATS=20 sets the contents of the last register accessed to 20.

If the number "n" is beyond the range of the S-Registers available, the modem will return the ERROR message. The value "v" is "MOD"ed with 256. If the result is outside the range permitted for a given S-Register the values will still be stored, but functionally the lower and higher limits will be observed. Input and output are always in decimal format. Note that some S-Registers are read-only.

In some cases, writing to the S-Register will appear to be accepted but the value will not actually be written.

Due to country restrictions, some commands will be accepted, but the value may be limited and replaced by a maximum or minimum value.

Minimum, maximum, and default values for S-Registers may be altered with ConfigurACE.

AT Commands for Central Site Modems Reference Manual

T - Set Tone Dial Default

This command forces DTMF dialing until the next P dial modifier or P command is received. The modem will set an S-Register bit to indicate that all subsequent dialing should be conducted in tone mode. Note that the DP command will override this command. Clears S14 bit 5.

This command may not be permitted in some countries. (See P.)

Result Code:

OK

Vn - Result Code Form

This command selects the sending of short-form or long-form result codes to the DTE. The parameter, if valid, is written to S14 bit 3.

V0 Enables short-form (terse) result codes. Line feed is not issued before a short-form result code.

V1 Enables long-form (verbose) result codes. (Default.)

Result Codes:

OK n = 0 or 1.

ERROR Otherwise.

Wn - Connect Message Control

This command controls the format of CONNECT messages. The parameter value, if valid, is written to S31 bits 2 and 3. Note that the Wn command can be overridden by register S95 bits (see S95 description).

W0 Upon connection, the modem reports only the DTE speed (e.g., CONNECT 19200). Subsequent responses are disabled. (Default.)

W1 Upon connection, the modem reports the line speed, the error correction protocol, and the DTE speed, respectively. Subsequent responses are disabled.

W2 Upon connection, the modem reports the DCE speed (e.g., CONNECT 14400). Subsequent responses are disabled.

Result Codes:

OK n = 0, 1, or 2.

ERROR Otherwise.

AT Commands for Central Site Modems Reference Manual

Xn - Extended Result Codes

This command selects which subset of the result messages will be used by the modem to inform the DTE of the results of commands.

Blind dialing is enabled or disabled by country parameters. If the user wishes to enforce dial tone detection, a "W" can be placed in the dial string (see D command). Note that the information below is based upon the default implementation of the X results table. Table 3-1 indicates the messages which are enabled for each X value.

If the modem is in facsimile mode (+FCLASS=1 or 2), the only message sent to indicate a connection is CONNECT without a speed indication.

- | | |
|----|--|
| X0 | Disables monitoring of busy tones unless forced otherwise by country requirements; send only OK, CONNECT, RING, NO CARRIER, ERROR, and NO ANSWER result codes. Blind dialing is enabled/disabled by country parameters. If busy tone detection is enforced and busy tone is detected, NO CARRIER will be reported. If dial tone detection is enforced or selected and dial tone is not detected, NO CARRIER will be reported instead of NO DIAL TONE. The value 000b is written to S22 bits 6, 5, and 4, respectively. |
| X1 | Disables monitoring of busy tones unless forced otherwise by country requirements; send only OK, CONNECT, RING, NO CARRIER, ERROR, NO ANSWER, and CONNECT XXXX (XXXX = rate). Blind dialing enabled/disabled by country parameters. If busy tone detection is enforced and busy tone is detected, NO CARRIER will be reported instead of BUSY. If dial tone detection is enforced or selected and dial tone is not detected, NO CARRIER will be reported instead of NO DIAL TONE. The value 100b is written to S22 bits 6, 5, and 4, respectively. |
| X2 | Disables monitoring of busy tones unless forced otherwise by country requirements; send only OK, CONNECT, RING, NO CARRIER, ERROR, NO DIALTONE, NO ANSWER, and CONNECT XXXX. If busy tone detection is enforced and busy tone is detected, NO CARRIER will be reported instead of BUSY. If dial tone detection is enforced or selected and dial tone is not detected, NO DIAL TONE will be reported instead of NO CARRIER. The value 101b is written to S22 bits 6, 5, and 4, respectively. |
| X3 | Enables monitoring of busy tones; send only OK, CONNECT, RING, NO CARRIER, ERROR, NO ANSWER, and CONNECT XXXX. Blind dialing is enabled/disabled by country parameters. If dial tone detection is enforced and dial tone is not detected, NO CARRIER will be reported. The value 110b is written to S22 bits 6, 5, and 4, respectively. |
| X4 | Enables monitoring of busy tones; send all messages. The value 111b is written to S22 bits 6, 5, and 4, respectively. (Default.) |

Result Codes:

- | | |
|-------|-------------|
| OK | n = 0 to 4. |
| ERROR | Otherwise. |

AT Commands for Central Site Modems Reference Manual

Table 3-1. Result Codes

Short Form	Long Form	n Value in ATXn Command					Notes
		0	1	2	3	4	
0	OK	x	x	x	x	x	
1	CONNECT	x	x	x	x	x	
2	RING	x	x	x	x	x	
3	NO CARRIER	x	x	x	x	x	
4	ERROR	x	x	x	x	x	
5	CONNECT 1200	1	x	x	x	x	
6	NO DIALTONE	3	3	x	x	x	
7	BUSY	3	3	3	x	x	
8	NO ANSWER	x	x	x	x	x	
9	CONNECT 0600	1	x	x	x	x	
10	CONNECT 2400	1	x	x	x	x	
11	CONNECT 4800	1	x	x	x	x	
12	CONNECT 9600	1	x	x	x	x	
13	CONNECT 7200	1	x	x	x	x	
14	CONNECT 12000	1	x	x	x	x	
15	CONNECT 14400	1	x	x	x	x	
16	CONNECT 19200	1	x	x	x	x	
17	CONNECT 38400	1	x	x	x	x	
18	CONNECT 57600	1	x	x	x	x	
19	CONNECT 115200	1	x	x	x	x	
20	CONNECT 230400	x	x	x	x	x	
22	CONNECT 75TX/1200RX	1	x	x	x	x	
23	CONNECT 1200TX/75RX	1	x	x	x	x	
24	DELAYED	4	4	4	4	x	
32	BLACKLISTED	4	4	4	4	x	
33	FAX	x	x	x	x	x	
35	DATA	x	x	x	x	x	
40	CARRIER 300	x	x	x	x	x	
44	CARRIER 1200/75	x	x	x	x	x	
45	CARRIER 75/1200	x	x	x	x	x	
46	CARRIER 1200	x	x	x	x	x	
47	CARRIER 2400	x	x	x	x	x	
48	CARRIER 4800	x	x	x	x	x	
49	CARRIER 7200	x	x	x	x	x	
50	CARRIER 9600	x	x	x	x	x	
51	CARRIER 12000	x	x	x	x	x	
52	CARRIER 14400	x	x	x	x	x	
53	CARRIER 16800	x	x	x	x	x	
54	CARRIER 19200	x	x	x	x	x	
55	CARRIER 21600	x	x	x	x	x	
56	CARRIER 24000	x	x	x	x	x	
57	CARRIER 26400	x	x	x	x	x	
58	CARRIER 28800	x	x	x	x	x	
59	CONNECT 16800	1	x	x	x	x	
61	CONNECT 21600	1	x	x	x	x	
62	CONNECT 24000	1	x	x	x	x	

AT Commands for Central Site Modems Reference Manual

Table 3-1. Result Codes (Cont'd)

Short Form	Long Form	n Value in ATXn Command					Notes
		0	1	2	3	4	
63	CONNECT 26400	1	x	x	x	x	
64	CONNECT 28800	1	x	x	x	x	
66	COMPRESSION: CLASS 5	x	x	x	x	x	
67	COMPRESSION: V.42 bis	x	x	x	x	x	
69	COMPRESSION: NONE	x	x	x	x	x	
70	PROTOCOL: NONE	x	x	x	x	x	
77	PROTOCOL: LAPM	x	x	x	x	x	
78	CARRIER 31200	x	x	x	x	x	
79	CARRIER 33600	x	x	x	x	x	
80	PROTOCOL: ALT	x	x	x	x	x	
81	PROTOCOL: ALT-CELLULAR	x	x	x	x	x	
84	CONNECT 33600	1	x	x	x	x	
91	CONNECT 31200	1	x	x	x	x	
150	CARRIER 32000	x	x	x	x	x	Note 2
151	CARRIER 34000	x	x	x	x	x	Note 2
152	CARRIER 36000	x	x	x	x	x	Note 2
153	CARRIER 38000	x	x	x	x	x	Note 2
154	CARRIER 40000	x	x	x	x	x	Note 2
155	CARRIER 42000	x	x	x	x	x	Note 2
156	CARRIER 44000	x	x	x	x	x	Note 2
157	CARRIER 46000	x	x	x	x	x	Note 2
158	CARRIER 48000	x	x	x	x	x	Note 2
159	CARRIER 50000	x	x	x	x	x	Note 2
160	CARRIER 52000	x	x	x	x	x	Note 2
161	CARRIER 54000	x	x	x	x	x	Note 2
162	CARRIER 56000	x	x	x	x	x	Note 2
165	CONNECT 32000	x	x	x	x	x	Note 2
166	CONNECT 34000	x	x	x	x	x	Note 2
167	CONNECT 36000	x	x	x	x	x	Note 2
168	CONNECT 38000	x	x	x	x	x	Note 2
169	CONNECT 40000	x	x	x	x	x	Note 2
170	CONNECT 42000	x	x	x	x	x	Note 2
171	CONNECT 44000	x	x	x	x	x	Note 2
172	CONNECT 46000	x	x	x	x	x	Note 2
173	CONNECT 48000	x	x	x	x	x	Note 2
174	CONNECT 50000	x	x	x	x	x	Note 2
175	CONNECT 52000	x	x	x	x	x	Note 2
176	CONNECT 54000	x	x	x	x	x	Note 2
177	CONNECT 56000	x	x	x	x	x	Note 2
+F4	+FCERROR	x	x	x	x	x	

Notes:

1. An 'x' in a column indicates that the message (either the long form if verbose, or the value only for short form) will be generated when that particular value of 'n' (shown at the top of the column) has been selected by the use of ATXn. If the column is blank, then no message will be generated for that x option. A numeral indicates which less explicit message (verbose or short form) will be output for that X option. (Also, see Section 3.3).
2. 56CSM modems.

AT Commands for Central Site Modems Reference Manual

Yn - Long Space Disconnect

This command enables/disables the generation and response to long space disconnect. The parameter value, if valid, is written to S21 bit 7.

Y0	Disables long space disconnect. (default.)
Y1	Enables long space disconnect. In non-error correction mode, the modem will send a long space of four seconds prior to going on-hook. In non-error correction mode, the modem will respond to the receipt of a long space (i.e., a break signal greater than 1.6 seconds) by going on-hook.

Result Codes:

OK	n = 0 or 1.
ERROR	Otherwise.

Zn - Soft Reset and Restore Profile

The modem performs a soft reset and restores (recalls) the configuration profile according to the parameter supplied. If no parameter is specified, zero is assumed.

Z0	Soft reset and restore stored profile 0.
Z1	Soft reset and restore stored profile 1.

Result Codes:

OK	n = 0 or 1.
ERROR	Otherwise.

AT Commands for Central Site Modems Reference Manual

3.2.2 AT& Commands

&Cn - RLSD (DCD) Option

The modem controls the RLSD output in accordance with the parameter supplied. The parameter value, if valid, is written to S21 bit 5.

&C0	RLSD remains ON at all times.
&C1	RLSD follows the state of the carrier. (Default.)

Result Codes:

OK	n = 0 or 1.
ERROR	Otherwise.

&Dn - DTR Option

This command interprets the ON to OFF transition of the DTR signal from the DTE in accordance with the parameter supplied. The parameter value, if valid, is written to S21 bits 3 and 4. Also, see S25.

&D0 -	DTR drop is interpreted according to the current &Qn setting as follows:
&Q0, &Q5, &Q6	DTR is ignored (assumed ON). Allows operation with DTEs which do not provide DTR.
&Q1, &Q4	DTR drop causes the modem to hang up. Auto-answer is not affected.
&Q2, &Q3	DTR drop causes the modem to hang up. Auto-answer is inhibited.
&D1	DTR drop is interpreted according to the current &Qn setting as follows:
&Q0, &Q1, &Q4, &Q5, &Q6	DTR drop is interpreted by the modem as if the asynchronous escape sequence had been entered. The modem returns to asynchronous command state without disconnecting.
&Q2, &Q3	DTR drop causes the modem to hang up. Auto-answer is inhibited.
&D2	DTR drop is interpreted according to the current &Qn setting as follows:
&Q0 through &Q6	DTR drop causes the modem to hang up. Auto-answer is inhibited. (Default.)
&D3	DTR drop is interpreted according to the current &Qn setting as follows:
&Q0, &Q1, &Q4, &Q5, &Q6	DTR drop causes the modem to perform a soft reset as if the Z command were received. The &Y setting determines which profile is loaded.
&Q2, &Q3	DTR drop causes the modem to hang up. Auto-answer is inhibited.

If &Q5, &Q6, +FCLASS=1 or +FCLASS=2 is in effect, the action taken is the same as for &Q0.

&Fn - Restore Factory Configuration (Profile)

The modem loads the factory default configuration (profile). The factory defaults are identified for each command and in the S-Register descriptions. A configuration (profile) consists of a subset of S-Registers.

&F0	Restore factory configuration 0.
&F1	Restore factory configuration 1.

Result Codes:

OK	
ERROR	If the modem is connected.

AT Commands for Central Site Modems Reference Manual

&Gn - Select Guard Tone

The modem generates the guard tone selected by this command according to the parameter supplied (DPSK modulation modes only). The parameter value, if valid, is written to S23 bits 6 and 7.

- &G0 Disables guard tone. (Default for US models.)
- &G1 Disables guard tone.
- &G2 Selects 1800 Hz guard tone. (Default for W-class models.)

This command may not be permitted in some countries.

Result Codes:

- OK n = 0 to 2.
- ERROR Otherwise.

&Jn - Telephone Jack Control

This command is included only for compatibility and performs no function except to load the S-Register. The parameter value, if valid, is written S21 bit 1.

- &J0 &J0 command. (Default.)
- &J1 &J1 command.

Result Codes:

- OK n = 0 or 1.
- ERROR Otherwise.

&Kn - Flow Control

This command defines the DTE/DCE (terminal/modem) flow control mechanism. The parameter value, if valid, is written to S39 bits 0, 1, and 2.

- &K0 Disables flow control.
- &K3 Enables RTS/CTS flow control. (Default for data modem modes.)
- &K4 Enables XON/XOFF flow control.
- &K5 Enables transparent XON/XOFF flow control.
- &K6 Enables both RTS/CTS and XON/XOFF flow control. (Default for fax modem and voice modes.)

Result Codes:

- OK n = 0, 3, 4, 5, or 6.
- ERROR Otherwise.

&Ln - Leased Line Operation

This command requests leased line or dial-up operation. This command is provided for compatibility only; no mode change is performed, dial-up operation continues. The OK response is returned for a valid parameter, but no other action is performed. The parameter value, if valid, is written to S27 bit 2.

- &L0 Requests dial-up operation. Dial-up operation continues.

Result Codes:

- OK n = 0.
- ERROR Otherwise.

AT Commands for Central Site Modems Reference Manual

&Mn - Asynchronous/Synchronous Mode Selection

This command determines the DTR operating mode. The modem treats the &M command as a subset of the &Q command.

- &M0 Selects direct asynchronous operation. Note that the command sequence &M0\N0 selects normal buffered mode, but the command sequence \N0&M0 selects direct mode. This is because the \N0 command is analogous to the &Q6 command. The value 000b is written to S27 bits 3, 1, and 0, respectively. (See &Q).
- &M1 Selects synchronous connect mode with async off-line command mode. The value 001b is written to S27 bits 3, 1, and 0, respectively. (Serial interface operation only.)
- &M2 Selects synchronous connect mode with async off-line command mode. Same as &M1 except that &M2 enables DTR dialing of directory slot 0. The modem will disconnect if DTR is OFF for more than the period in S25 (in units of hundredths of a second): the data connection will be synchronous. The value 010b is written to S27 bits 3, 1, and 0, respectively. (Serial interface operation only.)
- &M3 Selects synchronous connect mode. This mode allows DTR to act as a talk/data switch. The call is manually initiated while DTR is inactive. When DTR becomes active, the handshake proceeds in originate or answer mode according to S14 bit 7. The value 011b is written to S27 bits 3, 1, and 0, respectively. (Serial interface operation only.)

Result Codes:

- OK n = 0 to 3.
- ERROR Otherwise.

&Pn - Select Pulse Dial Make/Break Ratio

This command determines the make/break ratio used during pulse dialing. It is only effective if the appropriate bit to enable this command is set through the ConfigurACE program. If enabled, it will override the make/break ratios in the OEM parameters in ConfigurACE. The default is country-dependent. The parameter value, if valid, is written to S28 bits 3 and 4.

- &P0 Selects 39%-61% make/break ratio at 10 pulses per second. (Default.)
- &P1 Selects 33%-67% make/break ratio at 10 pulses per second.
- &P2 Selects 39%-61% make/break ratio at 20 pulses per second.
- &P3 Selects 33%-67% make/break ratio at 20 pulses per second.

Result Codes:

- OK n = 0 to 3.
- ERROR Otherwise.

AT Commands for Central Site Modems Reference Manual

&Qn - Sync/Async Mode

This command is an extension of the &M command and is used to control the connection modes permitted. It is used in conjunction with S36 and S48. (Also, see \N.)

NOTE: When the &Q0 to &Q4 command is issued to select the mode, the subsequent connect message will report the DCE speed regardless of the W command and S95 settings.

- | | |
|-----|---|
| &Q0 | Selects direct asynchronous operation. The value 000b is written to S27 bits 3, 1, and 0, respectively. See &M0. |
| &Q1 | Selects synchronous connect mode with async off-line command mode. The value 001b is written to S27 bits 3, 1, and 0, respectively. See &M1. (Serial interface operation only.) |
| &Q2 | Selects synchronous connect mode with async off-line command mode and enables DTR dialing of directory 0. The value 010b is written to S27 bits 3, 1, and 0, respectively. See &M2. (Serial interface operation only.) |
| &Q3 | Selects synchronous connect mode with async off-line command mode and enables DTR to act as Talk/Data switch. The value 011b is written to S27 bits 3, 1, and 0, respectively. See &M3. (Serial interface operation only.) |
| &Q4 | Selects AutoSync operation. The value 100b is written to S27 bits 3, 1, and 0, respectively.

AutoSync operation, when used in conjunction with the Hayes Synchronous Interface (HSI) capability in the DTE, provides synchronous communication capability from an asynchronous terminal.
Starting AutoSync. Set registers S19, S20, and S25 to the desired values before selecting AutoSync operation with &Q4. After the CONNECT message is issued, the modem waits the period of time specified by S25 before examining DTR. If DTR is on, the modem enters the synchronous operating state; if DTR is off, the modem terminates the line connection and returns to the asynchronous command state.
Stopping AutoSync. AutoSync operation is stopped upon loss of carrier or the on-to-off transition of DTR. Loss of carrier will cause the modem to return to the asynchronous command state. An on-to-off transition of DTR will cause the modem to return to the asynchronous command state and either not terminate the line connection (&D1 active) or terminate the line connection (any other &Dn command active). |
| &Q5 | The modem will try to negotiate an error-corrected link. The modem can be configured using S36 to determine whether a failure will result in the modem returning on-hook or will result in fallback to an asynchronous connection. The value 101b is written to S27 bits 3, 1, and 0, respectively. (Default.) |
| &Q6 | Selects asynchronous operation in normal mode (speed buffering). The value 110b is written to S27 bits 3, 1, and 0, respectively. |

Result Codes:

- | | |
|-------|-------------|
| OK | n = 0 to 6. |
| ERROR | Otherwise. |

&Rn - RTS/CTS Option

This selects how the modem controls CTS. CTS operation is modified if hardware flow control is selected (see &K command). The parameter value, if valid, is written to S21 bit 2.

- | | |
|-----|--|
| &R0 | In sync mode, CTS tracks the state of RTS; the RTS-to-CTS delay is defined by S26. In async mode, CTS is normally ON and will turn OFF only if required by flow control. |
| &R1 | In sync mode, CTS is always ON (RTS transitions are ignored). tracks the state of RTS; In async mode, CTS is normally ON and will turn OFF only if required by flow control. |

Result Codes:

- | | |
|-------|-------------|
| OK | n = 0 or 1. |
| ERROR | Otherwise. |

AT Commands for Central Site Modems Reference Manual

&Sn - DSR Override

This command selects how the modem will control DSR. The parameter value, if valid, is written to S21 bit 6.

- &S0 DSR will remain ON at all times. (Default.)
- &S1 DSR will become active after answer tone has been detected and inactive after the carrier has been lost.

Result Codes:

- OK n = 0 or 1.
- ERROR Otherwise.

&Tn - Test and Diagnostics

The modem will perform selected test and diagnostic functions according to the parameter supplied. A test can be run only when in an asynchronous operation in non-error-correction mode (normal or direct mode). To terminate a test in progress, the escape sequence must be entered first, except for parameters 7 and 8 (see Section 3.1.3). If S18 is non-zero, a test will terminate automatically after the time specified by S18 and display the OK message. Note: For tests 3, 6, and 7, a connection between the two modems must first be established.

- &T0 Terminates test in progress. Clears S16.
- &T1 Initiates local analog loopback, V.54 Loop 3. Sets S16 bit 0. If a connection exists when this command is issued, the modem hangs up. The CONNECT XXXX message is displayed upon the start of the test. Note that a loopback path from TXDATA to RXDATA is required.
- &T2 Returns ERROR.
- &T3 Initiates local digital loopback, V.54 Loop 2. Sets S16 bit 2. If no connection exists, ERROR is returned. Sets S16 bit 4 when the test is in progress.
- &T4 Enables digital loopback acknowledgment for remote request, i.e., an RDL request from a remote modem is allowed. Sets S23 bit 0.
- &T5 Disables digital loopback acknowledgment for remote request, i.e., an RDL request from a remote modem is denied. Clears S23 bit 0. (Default.)
- &T6 Requests a remote digital loopback (RDL), V.54 Loop 2, without self test. If no connection exists, ERROR is returned. Sets S16 bit 4 when the test is in progress. The CONNECT XXXX message is displayed upon the start of the test.
- &T7 Requests a remote digital loopback (RDL), V.54 Loop 2, with self test. (In self test, a test pattern is looped back and checked by the modem.) If no connection exists, ERROR is returned. When the test is terminated either via expiration of S18, or via the &T0 or H command, the number of detected errors is reported to the DTE. Sets S16 bit 5 when the test is in progress.
- &T8 Initiates local analog loopback, V.54 Loop 3, with self test. (In self test, a test pattern is looped back and checked by the modem.) If a connection exists, the modem hangs up before the test is initiated. When the test is terminated either via expiration of S18, or via the &T0 or H command, the number of detected errors is reported to the DTE. Sets S16 bit 6 when the test is in progress. This command may not be available in some countries due to PTT restrictions. Note that a loopback path from TXDATA to RXDATA is required.

AT Commands for Central Site Modems Reference Manual

&V - Display Current Configuration and Stored Profiles

Reports the current (active) configuration, the stored (user) profiles, and the first four stored telephone numbers. The stored profiles and telephone numbers are not displayed if the NVRAM is not installed or is not operational as detected by the NVRAM test during reset processing.

Result Code:

OK

Example:

```
AT&V
ACTIVE PROFILE:
B0 E1 L1 M1 N1 QO T V1 W0 X4 Y0 &C0 &D0 &G2 &J0 &K3 &Q5 &R1 &S0 &T4 &X0 &Y0
S00:002 S01:000 S02:043 S03:013 S04:010 S05:008 S06:002 S07:030 S08:002 S09:006
S10:014 S11:255 S12:050 S18:000 S25:005 S26:001 S36:007 S37:000 S38:020 S46:138
S48:007 S95:000

STORED PROFILE 0:
B0 E1 L1 M1 N1 QO T V1 W0 X4 Y0 &C0 &D0 &G2 &J0 &K3 &Q5 &R1 &S0 &T4 &X0
S00:002 S02:043 S06:002 S07:030 S08:002 S09:006 S10:014 S11:095 S12:050 S18:000
S36:007 S37:000 S40:105 S41:003 S46:138 S95:000

STORED PROFILE 1:
B0 E1 L1 M1 N1 QO T V1 W0 X4 Y0 &C0 &D0 &G2 &J0 &K3 &Q5 &R1 &S0 &T4 &X0
S00:002 S02:043 S06:002 S07:030 S08:002 S09:006 S10:014 S11:095 S12:050 S18:000
S36:007 S37:000 S40:105 S41:003 S46:138 S95:000

TELEPHONE NUMBERS:
0 = 1 =
2 = 3 =

OK
```

AT Commands for Central Site Modems Reference Manual

3.2.3 &V1 - Display Last Connection Statistics

Displays the last connection statistics in the following format (shown with typical results):

```
TERMINATION REASON..... LINK DISCONNECT or LOCAL REQUEST
LAST TX rate..... 48000 BPS
HIGHEST TX rate..... 48000 BPS
LAST RX rate..... 31200 BPS
HIGHEST RX rate..... 31200 BPS
PROTOCOL..... LAPM
COMPRESSION..... V42Bis
RX LEVEL..... 023
Highest SPX RX state..... 068
Highest SPX TX state..... 067
EQM Sum..... 0014
RBS Pattern..... 21
Rate Drop..... 04
Local Rtrn Count..... 00
Remote Rtrn Count..... 00
V8brs..... 9481812197
```

AT Commands for Central Site Modems Reference Manual

&Wn - Store Current Configuration

Saves the current (active) configuration (profile), including S-Registers, in one of the two user profiles in NVRAM as denoted by the parameter value. This command will yield an ERROR message if the NVRAM is not installed or is not operational as detected by the NVRAM test.

The current configuration is comprised of a list of storable parameters illustrated in the &V command. These settings are restored to the active configuration upon receiving an Zn command or at power up (see &Yn command).

- &W0 Store the current configuration as profile 0.
- &W1 Store the current configuration as profile 1.

Result Codes:

- OK n = 0 or 1.
- ERROR Otherwise.

&Xn - Select Synchronous Clock Source

Selects the source of the transmit clock for the synchronous mode of operation. The parameter value, if valid, is written to S27 bits 4 and 5.

In asynchronous mode, the transmit and receive clocks are turned OFF. In synchronous mode, the clocks are turned ON with the frequency of 1200 Hz or faster corresponding to the speed that is selected for modem operation.

- &X0 Selects internal timing. The modem generates the transmit clock signal and applies it to the TXCLK output at the serial interface.
- &X1 Selects external timing. The local DTE sources the transmit clock signal on the XTCLK input of the serial interface. The modem applies this clock to the TXCLK output at the serial interface.
- &X2 Selects slave receive timing. The modem derives the transmit clock signal from the incoming carrier and applies it to the TXCLK output at the serial interface.

Result Codes:

- OK n = 0 to 2.
- ERROR Otherwise.

&Yn - Designate a Default Reset Profile

Selects which user profile will be used after a hard reset.

- &Y0 The modem will use profile 0.
- &Y1 The modem will use profile 1.

Result Codes:

- OK n = 0 to 1.
- ERROR If n > 1, or if NVRAM is not installed or is not operational.

&Zn=x - Store Telephone Number

The modem can store up to four telephone numbers and each telephone number dial string can contain up to 34 digits.

- &Zn=x n = 0 to 3 and x = dial string. (Requires 256-byte NVRAM.)

Result Codes:

- OK For n ≤ 3, and x ≤ 34 digits.
- ERROR If n > 3, x > 35 digits, or if NVRAM is not installed or is not operational.

AT Commands for Central Site Modems Reference Manual

3.2.4 AT% Commands

%En - Enable/Disable Line Quality Monitor and Auto-Retrain or Fallback/Fall Forward

Controls whether or not the modem will automatically monitor the line quality and request a retrain (%E1) or fall back when line quality is insufficient or fall forward when line quality is sufficient (%E2). The parameter value, if valid, is written to S41 bits 2 and 6.

If enabled, the modem attempts to retrain for a maximum of 30 seconds.

%E0	Disable line quality monitor and auto-retrain.
%E1	Enable line quality monitor and auto-retrain.
%E2	Enable line quality monitor and fallback/fall forward. (Default.)

Result Codes:

OK	n = 0, 1, or 2.
ERROR	Otherwise.

Fallback/Fall Forward. When %E2 is active, the modem monitors the line quality (EQM). When line quality is insufficient, the modem will initiate a rate renegotiation to a lower speed within current modulation. The modem will keep falling back within the current modulation if necessary until the speed reaches 2400 bps (V.34) or 4800 bps (V.32). Below this rate, the modem will only do retrains if EQM thresholds are exceeded. If the EQM is sufficient for at least one minute, the modem will initiate a rate renegotiation to a higher speed within the current modulation speeds. The rate renegotiations will be done without a retrain if a V.32 bis connection is established.

Speeds attempted during fallback/fall forward are those shown to be available in the rate sequences exchanged during the initial connection. Fallback/fall forward is available in error correction and normal modes, but not in direct mode or synchronous mode with external clocks.

%L - Line Signal Level

Returns a value which indicates the received signal level. The value returned is a direct indication (DAA dependent) of the receive level at the MDP, **not** at the telephone line connector. For example, 009 = -9 dBm, 043 = -43 dBm, and so on.

Result Codes:

OK

%Q - Line Signal Quality

Reports the line signal quality (DAA dependent). Returns the higher order byte of the EQM value. Based on the EQM value, retrain or fallback/fall forward may be initiated if enabled by %E1 or %E2.

Example:

```
AT%Q
015
```

Result Codes:

OK	If connected.
ERROR	If not connected, or connected in 300 bps, V.23, or fax modes.

AT Commands for Central Site Modems Reference Manual

%7 - Plug and Play Serial Number

`%7<8 hex numbers><same 8 hex numbers><cr>` - Sets Plug and Play Serial Number

Sets and stores eight serial numbers in hex format used for serial Plug and Play and for ISA Plug and Play which use the Rockwell 11575 Plug and Play device.

Example:

```
AT%7<8 hex numbers><same 8 hex numbers>
```

Result Codes:

```
OK          <8 hex numbers><same 8 hex numbers>
ERROR       Otherwise
```

To display the stored serial number, issue `AT"?"<cr>`.

%8 - Plug and Play Vendor ID and Product Number

Sets and stores Vendor ID and product number for serial Plug and Play and for ISA Plug and Play which use the Rockwell 11575 Plug and Play device.

Example:

```
AT%8<3 ASCII characters><4 hex numbers><same 3 ASCII characters><same 4 hex numbers><cr>
```

Result Codes:

```
OK          <3 ASCII characters><4 hex numbers><same 3 ASCII characters><same 4 hex numbers>
ERROR       Otherwise
```

AT Commands for Central Site Modems Reference Manual

3.2.5 AT Commands

\Kn - Break Control

Controls the response of the modem to a break received from the DTE or the remote modem or the \B command according to the parameter supplied. The parameter value, if valid, is written to S40 bits 3, 4, and 5.

The response is different in three separate states.

The first state is where the modem receives a break from the DTE when the modem is operating in data transfer mode:

\K0	Enter on-line command mode, no break sent to the remote modem.
\K1	Clear data buffers and send break to remote modem.
\K2	Same as 0.
\K3	Send break to remote modem immediately.
\K4	Same as 0.
\K5	Send break to remote modem in sequence with transmitted data. (Default.)

The second case is where the modem is in the on-line command state (waiting for AT commands) during a data connection, and the \B is received in order to send a break to the remote modem:

\K0	Clear data buffers and send break to remote modem.
\K1	Clear data buffers and send break to remote modem. (Same as 0.)
\K2	Send break to remote modem immediately.
\K3	Send break to remote modem immediately. (Same as 2.)
\K4	Send break to remote modem in sequence with data.
\K5	Send break to remote modem in sequence with data. (Same as 4.) (Default.)

The third case is where a break is received from a remote modem during a non-error corrected connection:

\K0	Clears data buffers and sends break to the DTE.
\K1	Clears data buffers and sends break to the DTE. (Same as 0.)
\K2	Send a break immediately to DTE.
\K3	Send a break immediately to DTE. (Same as 2.)
\K4	Send a break in sequence with received data to DTE.
\K5	Send a break in sequence with received data to DTE. (Same as 4.) (Default.)

Result Codes:

OK	n = 0 to 5.
ERROR	Otherwise.

AT Commands for Central Site Modems Reference Manual

\Nn - Operating Mode

This command controls the preferred error correcting mode to be negotiated in a subsequent data connection. This command is affected by the OEM firmware configuration.

\N0	Selects normal speed buffered mode (disables error-correction mode). (Forces &Q6.)
\N1	Serial interface selected - Selects direct mode and is equivalent to &M0, &Q0 mode of operation. (Forces &Q0.) Parallel interface selected - Same as \N0.
\N2	Selects reliable (error-correction) mode. The modem will first attempt a LAPM connection and then an MNP connection. Failure to make a reliable connection results in the modem hanging up. (Forces &Q5, S36=4, and S48=7.)
\N3	Selects auto reliable mode. This operates the same as \N2 except failure to make a reliable connection results in the modem falling back to the speed buffered normal mode. (Forces &Q5, S36=7, and S48=7.)
\N4	Selects LAPM error-correction mode. Failure to make an LAPM error-correction connection results in the modem hanging up. (Forces &Q5 and S48=0.) Note: The -K1 command can override the \N4 command.
\N5	Selects MNP error-correction mode. Failure to make an MNP error-correction connection results in the modem hanging up. (Forces &Q5, S36=4, and S48=128.)

Result Codes:

OK	n = 0 to 5.
ERROR	Otherwise.

AT Commands for Central Site Modems Reference Manual

\Vn - Single Line Connect Message Enable

The single line connect message format can be enabled or disabled by the \Vn command as follows:

- \V0 Connect messages are controlled by the command settings X, W, and S95.
- \V1 Connect messages are displayed in the single line format described below subject to the command settings V (Verbose) and Q (Quiet). In Non-Verbose mode (V0), single line connect messages are disabled and a single numeric result code is generated for CONNECT DTE.

When single line connect messages are enabled, there are no CARRIER, PROTOCOL, or COMPRESSION messages apart from the fields described below.

The single line connect message format is:

CONNECT <DTE Speed></Modulation></Protocol></Compression></Line Speed></Voice and Data>

Where:

- <DTE Speed = DTE speed, e.g., 57600.
- Modulation = "K56" for K56flex modulations.
 "V32" for V.32 or V.32bis modulations.
 "V34" for V.34 modulations.

 Note: Modulation is omitted for all other modulations.
- Protocol = "NONE" for no protocol.
 "ALT" for Microcom Network Protocol.
 "LAPM" for LAP-M protocol.
- Compression = "CLASS5" for Microcom MNP5 compression.
 "V42BIS" for V.42bis compression.

 Note: Compression is omitted if protocol is NONE.
- Line Speed = Asymmetric rates are displayed as /rate:TX/rate:RX, e.g., /56000:TX/31200:RX For K56flex or /1200:TX/75:RX for V.23.
 Symmetric rates are displayed as a single DCE rate, e.g., 14400.
- Voice and Data = Blank for Data mode only.

AT Commands for Central Site Modems Reference Manual

3.2.6 AT+ Commands

+MS - Select Modulation

This extended-format command selects the modulation, optionally enables or disables automode, and optionally specifies the lowest and highest connection rates using one to four subparameters (client modem) or five subparameters (server modem). The command format is:

```
+MS= <mod> [, [<automode>], [<min_RX_rate>], [<max_RX_rate>], [<x_law>], [<rb_signaling>], [[<max_TX_rate>]]]]]]<CR>
```

Notes:

1. For 14400 bps and lower speeds, the Nn command and S37 register can alternatively be used, in which case the +MS subparameters will be modified to reflect the Nn and S37=x settings. Use of the Nn and S37=x commands is not recommended but is provided for compatibility with existing communication software. (S37 is not updated by the +MS command.)
2. Subparameters not entered (enter a comma only or <CR> to skip the last subparameter) remain at their current values.

Reporting Selected Options

The modem can send a string of information to the DTE consisting of selected options using the following command:

```
+MS?
```

The response is:

```
+MS: <mod>,<automode>,<min_RX_rate>,<max_RX_rate>,<x_law>,<rb_signaling>,<max_TX_rate>
```

For example,

```
+MS: 56,1,300,33600,0,0,56000 [default values]
```

Reporting Supported Options

The modem can send a string of information to the DTE consisting of supported options using the following command:

```
+MS=?
```

The response is:

```
+MS: (list of supported <mod> values), (list of supported <automode> values), (list of supported <min_RX_rate> values), (list of supported <max_RX_rate> values), (list of supported <x_law> values), (list of supported <rb_signaling> values), (list of supported max_TX_rate> values)
```

For example,

```
+MS: (0,1,2,3,9,10,11,56, 64,69),(0,1),(300-33600),(300-336000),(0,1),(0,1), (300-56000)
```

AT Commands for Central Site Modems Reference Manual

Subparameter Definitions

1. <mod> = A decimal number which specifies the preferred modulation (automode enabled) or the modulation (automode disabled) to use in originating or answering a connection. The options are:

<mod>	Modulation	Possible Rates (bps) ¹	Notes
0	V.21	300	
1	V.22	1200	
2	V.22 bis	2400 or 1200	
3	V.23	1200	See Note 2
9	V.32	9600 or 4800	
10	V.32 bis	14400, 12000, 9600, 7200, or 4800	
11	V.34	33600, 31200, 28800, 26400, 24000, 21600, 19200, 16800, 14400, 12000, 9600, 7200, 4800, or 2400	[default] for 336CSM
56	K56flex	56000, 54000, 52000, 50000, 48000, 46000, 44000, 42000, 40000, 38000, 36000, 34000, 32000	[default] for 56CSM
64	Bell 103	300	
69	Bell 212	1200	

Notes:

1. See optional <automode>, <min_RX_rate>, <max_RX_rate> and <max_TX_rate> subparameters.
2. For V.23, originating modes transmit at 75 bps and receive at 1200 bps; answering modes transmit at 1200 bps and receive at 75 bps. The rate is always specified as 1200 bps.

The modem may also automatically switch to another modulation (automode), subject to the following constraints:

- a. The modem may not be able to automatically switch from the current modulation (specified by <mod>) to some other modulation. For example, there is no standard way to automode from Bell 103 to V.23.
- b. The DTE may disable automode operation (see <automode> below).
- c. The DTE may constrain the range of modulations available by specifying the lowest and highest rates (see <min_rate> and <max_rate> below).

2. <automode> is an optional numeric value which enables or disables automatic modulation negotiation using V.8 bis/V.8 or V.32 bis Annex A. The options are:

<automode>	Option Selected	Notes
0	Automode disabled	
1	Automode enabled using V.8 bis/V.8 or V.32 Annex A	Default

The default value is 1, which enables automode. Note, however, there are modulations for which there is no automatic negotiation, e.g., Bell 212 (<mod> = 69).

For <automode> = 0 (automode disabled, i.e., fixed modulation):

- a. If <max_rate> is within the rates supported by the selected modulation, the selected rate is that specified by <max_rate>. For example:
+MS=10,0,1200,4800 selects V.32 bis 4800 bps fixed rate.
- b. If <max_rate> is greater than the highest speed supported by the modulation specified by <mod>, the starting rate is the highest rate supported by the selected modulation. For example:
+MS=10,0,2400,14400 selects V.32 bis 14400, 12000, 9600, 7200, or 4800 bps.

AT Commands for Central Site Modems Reference Manual

- c. To emulate issuance of the N0S37=x command sequence to select fixed mode operation, specify the <max_rate> and <min_rate> both to be the (same) requested speed, and <mod> to be the modulation for that speed. For example:

+MS=11,0,16800,16800 selects V.34 16800 bps fixed mode (no comparable S37 command).

+MS=10,0,12000,12000 selects V.32 bis 12000 bps fixed mode (same as N0S37=10).

For <automode> = 1 (automode enabled, i.e., automatically selected speed and modulation):

The modem connects at the highest possible rate in accordance with V.8 bis/V.8, or V.32 bis Annex A if V.8 bis/V.8 is not supported by the remote modem.

- a. If <max_rate> is greater than the highest rate supported by the modulation specified by <mod>, the modem automodes down from the highest rate of the selected modulation. For example:

+MS=10,1,1200,24000 selects automodging down from V.32 bis 14400 bps.

- b. To emulate issuance of the N1S37=x sequence command, specify the modulation and the rate to start automodging down from using <mod> and <max_rate>, respectively. Set <min_rate> to 300 to allow automodging all the way down to V.21 300 bps. For example:

+MS=11,1,300,16800 selects automode starting at V.34 16800 bps (no comparable S37 command).

+MS=9,1,300,12000 selects automode starting at V.32 bis 12000 bps (same as N1S37=10).

3. <min_RX_rate> is an optional number which specifies the lowest rate at which the modem may receive during a connection. The value is decimal coded, in units of bps, e.g., 2400 specifies the lowest rate to be 2400 bps. The default is 300 for 300 bps.
4. <max_RX_rate> is an optional number which specifies the highest rate at which the modem may receive during a connection. The value is decimal coded, in units of bps, e.g., 14400 specifies the highest rate to be 14400 bps. The default is 33600 for 33600 bps.
5. <x_low> is an optional number which specifies the codec type and is valid for the server modem only. Any value entered for the client modem is ignored. The server modem options are:
- 0 = μ -Law
 - 1 = A-Law
- Note that ATZ will reset the <x_low> selection to 0 (μ -Law)
6. <rb_signaling> is an optional number which enables and disables robbed bit signaling and detection and is valid for the client modem only. Any value entered for the server modem is ignored. The client modem options are:
- 0 = Robbed bit signaling disabled (default)
 - 1 = Robbed bit signaling enabled
- Note that ATZ will reset the <rb_signaling> selection to 0 (disabled)
7. <max_TX_rate> is an optional number which specifies the highest rate at which the modem may transmit during a connection. The value is decimal coded, in units of bps, e.g., 33600 specifies the highest rate to be 33600 bps. The default is 33600 (336CSM) or 56000 (56CSM).

AT Commands for Central Site Modems Reference Manual

3.2.7 AT** Command

** - Download to SRAM

Upon power turn-on or during normal operation, the AT** is used to activate modem Bootloader which then downloads the SRAM Loader into modem internal RAM, then the SRAM Loader downloads the CSM Modem Firmware into modem external SRAM. (Refer to the Bootloader description in the CSM device/device set designer's guide).

Download Procedure

1. Ensure CTS flow control is enabled.
2. Ensure that the SRAM Download file (XXXX.S37) and the Modem firmware S37 file (YYYYY.S37) are accessible to the system controller communications software.
3. Ensure the DTE rate is set to 57.6 Kbps.
4. Initiate the download process using the AT**n command, where:

AT** or AT**0	Download speed is the last sensed speed (recommended command).
AT**1	Download speed is 38.4k bps.
AT**2	Download speed is 57.6k bps.
5. When the AT** command is detected, the modem responds with "Download Initiated ...".
6. The modem then responds with "." as each line of the SRAM Loader S37 file is downloaded into MCU internal RAM. If a S37 file format error or bad checksum is detected for any line, the modem responds with "ERROR". If this occurs, reset the modem and restart the AT** sequence.
7. Upon SRAM Loader download completion, the modem responds with "Download Modem Firmware ...".
8. The modem then responds with "." as each line of the "Modem Firmware" S37 file is downloaded in to the modem external SRAM. If a S37 file format error, or bad checksum is detected for any line, the modem responds with "Download ABORT". If this occurs, reset the modem and restart the AT** sequence.
9. Upon CSM Modem Firmware download completion, the modem responds with "Device successfully programmed". The modem then starts executing code from the modem external SRAM, at the Reset Vector, and begins normal modem operation.

3.2.8 AT- Commands

-SDR=n - Enable/Disable Distinctive Ring

This command enables or disables detection and reporting of distinctive ring. The syntax is AT-SDR=n, where n is a number from 0 to 7. One, two, or three distinctive ring types can be simultaneously enabled depending upon the value of n (bit mapped). The detected ring type is reported in the long form (verbose) of the result code by appending the ring type number to the end of the RING message.

-SDR=0	Disables Distinctive Ring. Any valid ring detected is reported as RING (default).
-SDR=1	Enables Distinctive Ring Type 1.
-SDR=2	Enables Distinctive Ring Type 2.
-SDR=3	Enables Distinctive Ring Type 1 and 2.
-SDR=4	Enables Distinctive Ring Type 3.
-SDR=5	Enables Distinctive Ring Type 1 and 3.
-SDR=6	Enables Distinctive Ring Type 2 and 3.
-SDR=7	Enables Distinctive Ring Type 1, 2, and 3.

Result Codes:

OK	n = 0 to 7.
ERROR	Otherwise.

The n value bit map is:

Bit 0=1	Enable RING type 1. RING type 1 is detected and reported as RING1.
Bit 1=1	Enable RING type 2. RING type 2 is detected and reported as RING2.

AT Commands for Central Site Modems Reference Manual

Bit 2=1 Enable RING type 3. RING type 3 is detected and reported as RING3.

The ring types supported and the corresponding ring cadence detect criteria are:

Distinctive Ring Type	Ring Cadence Detect Criteria
1	2.0 sec ON, 4.0 sec OFF.
2	0.8 sec ON, 0.4 sec OFF, 0.8 sec ON, 4.0 sec OFF.
3	0.4 sec ON, 0.2 sec OFF, 0.4 sec ON, 0.2 sec OFF, 0.8 sec ON, 4.0 sec OFF.

Notes:

1. The Ring Indicate (RI) output does not toggle on the first ring if AT-SDR_0.
2. The RI output waveform is the same for all ring types detected, i.e., RI is on for the total duration of the ring period.

AT Commands for Central Site Modems Reference Manual

3.3 ERROR DETECTION AND DATA COMPRESSION COMMANDS

3.3.1 AT% Commands

%C - Enable/Disable Data Compression

Enables or disables data compression negotiation. The modem can only perform data compression on an error corrected link. The parameter value, if valid, is written to S41 bits 0 and 1.

%C0	Disables data compression. Resets S46 bit 1.
%C1	Enables MNP 5 data compression negotiation. Resets S46 bit 1.
%C2	Enables V.42 bis data compression. Sets S46 bit 1.
%C3	Enables both V.42 bis and MNP 5 data compression. Sets S46 bit 1. (Default.)

Result Codes:

OK	n = 0, 1, 2, or 3.
ERROR	Otherwise.

3.3.2 AT\ Commands

\An - Select Maximum MNP Block Size

The modem will operate an MNP error corrected link using a maximum block size controlled by the parameter supplied. The parameter value, if valid, is written to S40 bits 6 and 7.

\A0	64 characters.
\A1	128 characters. (Default.)
\A2	192 characters.
\A3	256 characters.

Result Codes:

OK	n = 0 to 3.
ERROR	Otherwise.

\Bn - Transmit Break to Remote

In non-error correction mode, the modem will transmit a break signal to the remote modem with a length in multiples of 100 ms according to parameter specified. If a number in excess of 9 is entered, 9 is used. The command works in conjunction with the \K command.

In error correction mode, the modem will signal a break through the active error correction protocol, giving no indication of the length.

\B1-B9	Break length in 100 ms units. (Default = 3.) (Non-error corrected mode only.)
--------	---

Result Codes:

OK	If connected in data modem mode.
NO CARRIER	If not connected or connected in fax modem mode.

Note: When the modem receives a break from the remote modem, break is passed to the DTE as follows: In non-error correction mode direct, the break length is passed; in non-error correction mode normal and in error correction mode, a 300 ms break is passed.

AT Commands for Central Site Modems Reference Manual

3.4 MNP 10 COMMANDS

3.4.1 AT) Commands

)Mn - Enable Cellular Power Level Adjustment

This command is included only for compatibility and performs no function.

)M0)M0 command.
)M1)M1 command.
)M2)M2 command.

Result Codes:

OK	n = 0 to 2.
ERROR	Otherwise.

*Hn - Link Negotiation Speed

This command is included only for compatibility and performs no function.

*H0	*H0 command.
*H1	*H1 command.
*H2	*H2 command.

Result Codes:

OK	n = 0 to 2.
ERROR	Otherwise.

-Kn - MNP Extended Services

Enables or disables conversion of a V.42 LAPM connection to an MNP 10 connection. The parameter value, if valid, is written to S40 bits 0 and 1.

-K0	Disables V.42 LAPM to MNP 10 conversion. (Default.)
-K1	Enables V.42 LAPM to MNP 10 conversion.
-K2	Enables V.42 LAPM to MNP 10 conversion; inhibits MNP Extended Services initiation during V.42 LAPM answer mode detection phase.

Result Codes:

OK	n = 0 or 2.
ERROR	Otherwise.

-Qn - Enable Fallback to V.22 bis/V.22

This command is included only for compatibility and performs no function.

-Q0	-Q0 command.
-Q1	-Q1 command.

Result Codes:

OK	n = 0 or 1.
ERROR	Otherwise.

AT Commands for Central Site Modems Reference Manual

-SEC=n - Enable/Disable MNP10-EC

Enables or disables MNP10-EC operation. The command format is:

- | | |
|---------------------|---|
| -SEC=n,[<tx level>] | where <tx level> is the optional transmit level sub parameter. |
| -SEC=0 | Disable MNP10-EC; the transmit level is that defined in S91. |
| -SEC=1,[<tx level>] | Enable MNP10-EC; the transmit level will be defined by the sub parameter <tx level> range 0 to 30 (0 dBm to -30 dBm), the default <tx level> (<tx level> not specified) is the S91 value. |

Result Codes:

- | | |
|-------|-------------------------------------|
| OK | n=0, 1, or 1 and <tx level>=0 to 30 |
| ERROR | Otherwise |

Example: AT-SEC=1,18 enables MNP10-EC and sets the transmit level to -18 dBm.

Note: If AT-SEC=0, the modem will automatically set AT-SEC=1 if the remote modem indicates Cellular in the V.8 bis/V.8 phase or if a Cellular Driver is loaded and the Cell Phone is attached.

Inquiries

- | | |
|---------|--|
| AT-SEC? | Retrieves the current -SEC command settings, e.g., 1,18. |
|---------|--|

@Mn - Initial Cellular Power Level Setting

This command is included only for compatibility and performs no function.

- | | |
|------|---------------|
| @M0 | @M0 command. |
| . | . |
| . | . |
| . | . |
| @M30 | @M30 command. |

Result Codes:

- | | |
|-------|--------------|
| OK | n = 0 to 30. |
| ERROR | Otherwise. |

:E - Compromise Equalizer Enable Command

This command is included only for compatibility and performs no function.

- | | |
|-----|--------------|
| :E0 | :E0 command. |
| :E1 | :E1 command. |

Result Codes:

- | | |
|-------|-------------|
| OK | n = 0 or 1. |
| ERROR | Otherwise. |

AT Commands for Central Site Modems Reference Manual

3.5 W-CLASS COMMANDS

3.5.1 AT* Commands

*B - Display Blacklisted Numbers

This command requests the modem to return a list of blacklisted numbers to the DTE. The format of the response is shown by the example below. Permanently forbidden numbers as defined by country requirements will not appear on this list. If no numbers are blacklisted, only the OK result code is issued.

Example:

```
NO. - PHONE NUMBER -  
-----  
1; 4175537660  
2; 8288924961  
3; 3887278862  
4; 3124839442  
5; 6284664  
  
OK
```

*D - Display Delayed Numbers

This command causes the modem to send a list of the delayed numbers together with the delay associated with each. The modem will return a list of delayed telephone numbers as defined in the *B command. The format of the response is shown by the example below (delay times are shown as hours:minutes:seconds). If no numbers are delayed, only the OK result code is issued.

Example:

```
NO. - PHONE NUMBER -DELAY  
-----  
1; 8264734660 2:00:00  
2; 7532634661 2:00:00  
3; 2587334662 0:02:00  
4; 7532651663 0:03:25  
5; 7459931664 0:01:45  
  
OK
```

AT Commands for Central Site Modems Reference Manual

*NCn - Country Select

Up to four sets of country parameters may be stored in the EPROM. This command checks to see if the entered number matches the country code of one of the countries stored in the EPROM. If found, the modem stores the location of that country in NVRAM. Upon power up or a soft reset (Z command), the modem uses this location to load the parameters for the corresponding country. The default value of zero is used if no NVRAM is installed or the NVRAM failed self test during reset.

Note: Automatic DAA country code recognition is enabled by the *NC0 command (the 0 country code is reserved for this function). Automatic DAA country code recognition is disabled by the *NCn command selecting any other valid country code.

*NCn Select country parameters corresponding to entered country code (n). The country codes are:

Country	Code (n)
Australia	40
Austria	1
Belgium	2
Bulgaria	27
Canada	20
China	41
Czech Republic	19
Denmark	3
Finland	4
France	5
Germany	6
Greece	17
Hong Kong	42
Hungary	23
India	30
Ireland	7
Israel	18
Italy	8
Japan	43
Korea	44
Luxembourg	9
Mexico	21
Netherlands	10
New Zealand	48
Norway	11
Philippines	43
Poland	24
Portugal	12
Russia	25
Singapore	47
Slovak Republic	26
Spain	13
Sweden	14
Switzerland	15
Taiwan	46
United Kingdom	16
United States	22

Result Codes:

OK If parameters corresponding to entered country code are present in EPROM.
ERROR Otherwise.

AT Commands for Central Site Modems Reference Manual

3.6 AT COMMAND RESULT CODES

The modem responds to commands from the DTE and to activity on the line by signalling to the DTE in the form of result codes. The result codes that the modem can send are described below.

Two forms of each result code are available: long-form, an English-like "verbose" response, and short-form, a data-like numeric response (included in parentheses following the long-form). The long-form code is preceded and terminated by the sequence < CR> < LF>. The short-form is terminated by < CR>, only with no preceding sequence.

If result messages are suppressed, nothing is returned to the DTE. The long-form results codes can be modified by the OEM through the ConfigurACE Configuration Utility Program. (See ConfigurACE description.)

OK (0)

The OK code is returned by the modem to acknowledge execution of a command line.

CONNECT (1)

The modem will send this result code upon connecting when:

1. The line speed is 300 bps and the modem has been instructed to report the line speed to the DTE upon connecting, or
2. The DTE speed is 300 bps and the modem has been instructed to report the DTE speed to the DTE upon connecting, or
3. The range of result code responses is restricted by the X command such that no speed reporting is allowed.

RING (2)

The modem sends this result code when incoming ringing is detected on the line. What qualifies as a ring signal is determined by country-dependent parameters, modifiable through ConfigurACE.

When cellular interface is selected, RING indicates that the cellular phone is receiving an incoming call.

NO CARRIER (3)

The modem sends this result code when attempting to establish a call if:

1. Ringback is detected and later ceases but no carrier is detected within the period of time determined by register S7, or
2. No ringback is detected within the period of time determined by register S7.

This result code is also used when the modem auto-disconnects due to loss of carrier.

Under X0, if busy tone detection is enforced, this result code is used as a response to the detection of busy or circuit busy. Under X0, if dial tone detection is enforced or selected, this result code is used to indicate that dial tone has not been detected.

ERROR (4)

The modem returns this result code if the command line contains a syntax error or it is unable to execute a command contained in the command line. It is issued if a command does not exist or if the parameter supplied is outside the permitted range.

Under X0, X1, X2, and X3, this result is used instead of DELAYED and BLACKLISTED.

CONNECT 1200 (5)

For X1, X2, X3, and X4, the modem sends this result code when:

1. The line speed is 1200 bps and the modem has been instructed to report the line speed to the DTE upon connecting, or
2. The DTE speed is 1200 bps and the modem has been instructed to report the DTE speed to the DTE upon connecting.

(Also, see the W command.)

NO DIALTONE (6)

For X2 and X4, the modem sends this result code if it has been instructed to wait for dial tone during dialing but none is received.

When cellular phone interface is selected, NO DIALTONE indicates that cellular service is not currently available.

AT Commands for Central Site Modems Reference Manual

BUSY (7)

For X3 and X4, if busy tone detection is enforced, the modem sends this result code when attempting to originate a call if the busy (engaged) signal is detected on the line.

NO ANSWER (8)

The modem sends this result code when attempting to originate a call if a continuous ringback signal is detected on the line until the expiration of the timer S7.

CONNECT 0600 (9)

For X1, X2, X3, and X4, the modem sends this result code when:

1. The line speed is 600 bps and the modem has been instructed to report the line speed to the DTE upon connecting, or
2. The DTE speed is 600 bps and the modem has been instructed to report the DTE speed to the DTE upon connecting.

CONNECT 2400 (10)

For X1, X2, X3, and X4, the modem sends this result code when:

1. The line speed is 2400 bps and the modem has been instructed to report the line speed to the DTE upon connecting, or
2. The DTE speed is 2400 bps and the modem has been instructed to report the DTE speed to the DTE upon connecting.

CONNECT 4800 (11)

For X1, X2, X3, and X4, the modem sends this result code when:

1. The line speed is 4800 bps and the modem has been instructed to report the line speed to the DTE upon connecting, or
2. The DTE speed is 4800 bps and the modem has been instructed to report the DTE speed to the DTE upon connecting.

CONNECT 9600 (12)

For X1, X2, X3, and X4, the modem sends this result code when:

1. The line speed is 9600 bps and the modem has been instructed to report the line speed to the DTE upon connecting, or
2. The DTE speed is 9600 bps and the modem has been instructed to report the DTE speed to the DTE upon connecting.

CONNECT 7200 (13)

For X1, X2, X3, and X4, the modem sends this result code when:

1. The line speed is 7200 bps and the modem has been instructed to report the line speed to the DTE upon connecting, or
2. The DTE speed is 7200 bps and the modem has been instructed to report the DTE speed to the DTE upon connecting.

CONNECT 12000 (14)

For X1, X2, X3, and X4, the modem sends this result code when:

1. The line speed is 12000 bps and the modem has been instructed to report the line speed to the DTE upon connecting,
or
2. The DTE speed is 12000 bps and the modem has been instructed to report the DTE speed to the DTE upon connecting.

CONNECT 14400 (15)

For X1, X2, X3, and X4, the modem sends this result code when:

1. The line speed is 14400 bps and the modem has been instructed to report the line speed to the DTE upon connecting,
or
2. The DTE speed is 14400 bps and the modem has been instructed to report the DTE speed to the DTE upon connecting.

CONNECT 19200 (16)

For X1, X2, X3, and X4, the modem sends this result code when:

1. The line speed is 19200 bps and the modem has been instructed to report the line speed to the DTE upon connecting,
or

AT Commands for Central Site Modems Reference Manual

2. The DTE speed is 19200 bps and the modem has been instructed to report the DTE speed to the DTE upon connecting.

CONNECT 38400 (17)

For X1, X2, X3, and X4, the modem sends this result code upon connecting when the DTE speed is 38400 bps and the modem has been instructed to report the DTE speed to the DTE upon connecting.

CONNECT 57600 (18)

For X1, X2, X3, and X4, the modem sends this result code upon connecting when the DTE speed is 57600 bps and the modem has been instructed to report the DTE speed to the DTE upon connecting.

CONNECT 115200 (19)

For X1, X2, X3, and X4, the modem sends this result code upon connecting when the DTE speed is 115200 bps and the modem has been instructed to report the DTE speed to the DTE upon connecting.

CONNECT 75TX/1200RX (22)

For X1, X2, X3, and X4, the modem returns this result code upon establishing a V.23 originate connection when the modem has been instructed to report the DCE speed upon connection.

CONNECT 1200TX/75RX (23)

For X1, X2, X3, and X4, the modem returns this result code upon establishing a V.23 answer connection when the modem has been instructed to report the DCE speed upon connection.

DELAYED (24)

For X4, the modem returns this result code when a call fails to connect and the number dialed is considered 'delayed' due to country blacklisting requirements.

BLACKLISTED (32)

For X4, the modem returns this result code when a call fails to connect and the number dialed is considered 'blacklisted'.

FAX (33)

The modem returns this result code when a fax modem connection is established in a facsimile mode.

DATA (35)

The modem returns this result code when a data modem connection is established in a facsimile mode.

CARRIER 300 (40)

The modem returns this result code when a 0-300 bps data rate has been detected on the line and carrier reporting has been enabled. (See S95 and Xn.)

CARRIER 1200/75 (44)

The modem sends this result code when the V.23 backward channel carrier has been detected on the line and carrier reporting has been enabled. (See S95 and Xn.)

CARRIER 75/1200 (45)

The modem sends this result code when the V.23 forward channel carrier has been detected on the line and carrier reporting has been enabled. (See S95 and Xn.)

CARRIER 1200 (46)

The modem sends this result code when a 1200 bps data rate has been detected on the line and carrier reporting has been enabled. (See S95 and Xn.)

CARRIER 2400 (47)

The modem sends this result code when a 2400 bps data rate has been detected on the line and carrier reporting has been enabled. (See S95 and Xn.)

CARRIER 4800 (48)

The modem sends this result code when a 4800 bps data rate has been detected on the line and carrier reporting has been enabled. (See S95 and Xn.)

AT Commands for Central Site Modems Reference Manual

CARRIER 7200 (49)

The modem sends this result code when a 7200 bps data rate has been detected on the line and carrier reporting has been enabled. (See S95 and Xn.)

CARRIER 9600 (50)

The modem sends this result code when a 9600 bps data rate has been detected on the line and carrier reporting has been enabled. (See S95 and Xn.)

CARRIER 12000 (51)

The modem sends this result code when a 12000 bps data rate has been detected on the line and carrier reporting has been enabled. (See S95 and Xn.)

CARRIER 14400 (52)

The modem sends this result code when a 14400 bps data rate has been detected on the line and carrier reporting has been enabled. (See S95 and Xn.)

CARRIER 16800 (53)

The modem sends this result code when a 16800 bps data rate has been detected on the line and carrier reporting has been enabled. (See S95 and Xn.)

CARRIER 19200 (54)

The modem sends this result code when a 19200 bps data rate has been detected on the line and carrier reporting has been enabled. (See S95 and Xn.)

CARRIER 21600 (55)

The modem sends this result code when a 21600 bps data rate has been detected on the line and carrier reporting has been enabled. (See S95 and Xn.)

CARRIER 24000 (56)

The modem sends this result code when a 24000 bps data rate has been detected on the line and carrier reporting has been enabled. (See S95 and Xn.)

CARRIER 26400 (57)

The modem sends this result code when a 26400 bps data rate has been detected on the line and carrier reporting has been enabled. (See S95 and Xn.)

CARRIER 28800 (58)

The modem sends this result code when a 28800 bps data rate has been detected on the line and carrier reporting has been enabled. (See S95 and Xn.)

CONNECT 16800 (59)

For X1, X2, X3, and X4, the modem returns this result code upon connecting when the DTE speed is 16800 bps and the modem has been instructed to report the DTE speed upon connecting.

CONNECT 21600 (61)

For X1, X2, X3, and X4, the modem returns this result code upon connecting when the DTE speed is 21600 bps and the modem has been instructed to report the DTE speed upon connecting.

CONNECT 24000 (62)

For X1, X2, X3, and X4, the modem returns this result code upon connecting when the DTE speed is 24000 bps and the modem has been instructed to report the DTE speed upon connecting.

CONNECT 26400 (63)

For X1, X2, X3, and X4, the modem returns this result code upon connecting when the DTE speed is 26400 bps and the modem has been instructed to report the DTE speed upon connecting.

AT Commands for Central Site Modems Reference Manual

CONNECT 28800 (64)

For X1, X2, X3, and X4, the modem returns this result code upon connecting when the DTE speed is 28800 bps and the modem has been instructed to report the DTE speed upon connecting.

COMPRESSION: CLASS 5 (66)

This message is sent to the DTE when the modem has connected in MNP Class 5 and COMPRESSION message reporting has been enabled. (See S95 and Xn.)

COMPRESSION: V.42 bis (67)

This message is sent to the DTE when the modem has connected in V.42 bis and COMPRESSION message reporting has been enabled. (See S95 and Xn.)

COMPRESSION: NONE (69)

This message is sent to the DTE when the modem has connected without data compression and COMPRESSION message reporting has been enabled. (See S95 and Xn.)

PROTOCOL: NONE (70)

This message is sent to the DTE when the modem has connected without any form of error correction, and the PROTOCOL message reporting has been enabled. (See S95 and Xn.)

PROTOCOL: LAPM (77)

This message is sent to the DTE when the modem has connected in the V.42 LAPM mode of error correction, and PROTOCOL message reporting has been enabled. (See S95 and Xn.)

CARRIER 31200 (78)

The modem sends this result code when a 31200 bps data rate has been detected on the line and carrier reporting has been enabled. (See S95 and Xn.)

CARRIER 33600 (79)

The modem sends this result code when a 33600 bps data rate has been detected on the line and carrier reporting has been enabled. (See S95 and Xn.)

PROTOCOL: ALT (80)

This message is sent to the DTE when the modem has connected in the MNP mode of error correction, and PROTOCOL message reporting has been enabled. (See S95 and Xn.)

PROTOCOL: ALT-CELLULAR (81)

This message is sent to the DTE when the modem has connected in the MNP 10 mode and cellular power level adjustment is enabled ("M1 or M2"). (See S95 and Xn.)

CONNECT 33600 (84)

For X1, X2, X3, and X4, the modem returns this result code upon connecting when the DTE speed is 33600 bps and the modem has been instructed to report the DTE speed upon connecting.

CONNECT 31200 (91)

For X1, X2, X3, and X4, the modem returns this result code upon connecting when the DTE speed is 31200 bps and the modem has been instructed to report the DTE speed upon connecting.

CARRIER 32000 (150)

The modem sends this result code when a 32000 bps data rate has been detected on the line and carrier reporting has been enabled. (See S95 and Xn.)

CARRIER 34000 (151)

The modem sends this result code when a 34000 bps data rate has been detected on the line and carrier reporting has been enabled. (See S95 and Xn.)

AT Commands for Central Site Modems Reference Manual

CARRIER 36000 (152)

The modem sends this result code when a 36000 bps data rate has been detected on the line and carrier reporting has been enabled. (See S95 and Xn.)

CARRIER 38000 (153)

The modem sends this result code when a 38000 bps data rate has been detected on the line and carrier reporting has been enabled. (See S95 and Xn.)

CARRIER 40000 (154)

The modem sends this result code when a 40000 bps data rate has been detected on the line and carrier reporting has been enabled. (See S95 and Xn.)

CARRIER 42000 (155)

The modem sends this result code when a 42000 bps data rate has been detected on the line and carrier reporting has been enabled. (See S95 and Xn.)

CARRIER 44000 (156)

The modem sends this result code when a 44000 bps data rate has been detected on the line and carrier reporting has been enabled. (See S95 and Xn.)

CARRIER 46000 (157)

The modem sends this result code when a 46000 bps data rate has been detected on the line and carrier reporting has been enabled. (See S95 and Xn.)

CARRIER 48000 (158)

The modem sends this result code when a 48000 bps data rate has been detected on the line and carrier reporting has been enabled. (See S95 and Xn.)

CARRIER 50000 (159)

The modem sends this result code when a 50000 bps data rate has been detected on the line and carrier reporting has been enabled. (See S95 and Xn.)

CARRIER 52000 (160)

The modem sends this result code when a 52000 bps data rate has been detected on the line and carrier reporting has been enabled. (See S95 and Xn.)

CARRIER 54000 (161)

The modem sends this result code when a 54000 bps data rate has been detected on the line and carrier reporting has been enabled. (See S95 and Xn.)

CARRIER 56000 (162)

The modem sends this result code when a 56000 bps data rate has been detected on the line and carrier reporting has been enabled. (See S95 and Xn.)

CONNECT 32000 (165)

For X1, X2, X3, and X4, the modem returns this result code upon connecting when the DTE speed is 32000 bps and the modem has been instructed to report the DTE speed upon connecting.

CONNECT 34000 (166)

For X1, X2, X3, and X4, the modem returns this result code upon connecting when the DTE speed is 34000 bps and the modem has been instructed to report the DTE speed upon connecting.

CONNECT 36000 (167)

For X1, X2, X3, and X4, the modem returns this result code upon connecting when the DTE speed is 36000 bps and the modem has been instructed to report the DTE speed upon connecting.

AT Commands for Central Site Modems Reference Manual

CONNECT 38000 (168)

For X1, X2, X3, and X4, the modem returns this result code upon connecting when the DTE speed is 38000 bps and the modem has been instructed to report the DTE speed upon connecting.

CONNECT 40000 (169)

For X1, X2, X3, and X4, the modem returns this result code upon connecting when the DTE speed is 40000 bps and the modem has been instructed to report the DTE speed upon connecting.

CONNECT 42000 (170)

For X1, X2, X3, and X4, the modem returns this result code upon connecting when the DTE speed is 42000 bps and the modem has been instructed to report the DTE speed upon connecting.

CONNECT 44000 (171)

For X1, X2, X3, and X4, the modem returns this result code upon connecting when the DTE speed is 44000 bps and the modem has been instructed to report the DTE speed upon connecting.

CONNECT 46000 (172)

For X1, X2, X3, and X4, the modem returns this result code upon connecting when the DTE speed is 46000 bps and the modem has been instructed to report the DTE speed upon connecting.

CONNECT 48000 (173)

For X1, X2, X3, and X4, the modem returns this result code upon connecting when the DTE speed is 48000 bps and the modem has been instructed to report the DTE speed upon connecting.

CONNECT 50000 (174)

For X1, X2, X3, and X4, the modem returns this result code upon connecting when the DTE speed is 50000 bps and the modem has been instructed to report the DTE speed upon connecting.

CONNECT 52000 (175)

For X1, X2, X3, and X4, the modem returns this result code upon connecting when the DTE speed is 52000 bps and the modem has been instructed to report the DTE speed upon connecting.

CONNECT 54000 (176)

For X1, X2, X3, and X4, the modem returns this result code upon connecting when the DTE speed is 54000 bps and the modem has been instructed to report the DTE speed upon connecting.

CONNECT 56000 (177)

For X1, X2, X3, and X4, the modem returns this result code upon connecting when the DTE speed is 56000 bps and the modem has been instructed to report the DTE speed upon connecting.

CONNECT 230400 (20)

For X1, X2, X3, and X4, the modem returns this result code upon connecting when the DTE speed is 230400 bps and the modem has been instructed to report the DTE speed upon connecting.

+FCERROR (+F4)

This message is sent to the DTE when high speed fax data (V.27, V.29, V.33, or V.17) is expected and a V.21 signal is received.

AT Commands for Central Site Modems Reference Manual

3.7 CSM UNIQUE COMMANDS

3.7.1 +ISP Command - Select Pass-Through Mode or POTS Modem Connection

The +ISP=n command selects pass-through mode or POTS modem connection. The command syntax is:

+ISP=n

where:

n = 0	64 kbps pass-through mode (see +ES command)
n = 1	56 kbps pass-through mode (see +ES command)
n = 2	POTS modem connection (the +ES command is ignored)

3.7.2 +ES Command - Select Frame Tunneling Mode

When a pass-through mode is selected by the +ISP command, the +ES command is used to optionally select frame tunneling mode with <orig_rqst> parameter set to 7 and <ans_fbk> parameter set to 9.

The complete command syntax is:

+ES=[<orig_rqst>[,<orig_fbk>[,<ans_fbk>]]]

These extended-format compound parameters are defined as follows:

<orig_rqst>, which specifies the initial requested mode of operation when the DCE is operating as the originator.

<orig_fbk>, which specifies the acceptable fallback mode of operation when the DCE is operating as the originator.

<ans_fbk>, which specifies the acceptable fallback mode of operation when the DCE is operating as the answerer.

Note that for the CSM application, only <orig_rqst> parameter set to 7 and <ans_fbk> parameter set to 9 are used. The <orig_fbk> field is ignored and should be set to zero.

<orig_rqst> description

0 -6 = Frame Tunneling Mode is not selected.

7 = Initiate Frame Tunneling Mode when connection is completed, and Data State is entered.

<orig_fbk> description

0 = Parameter is ignored

<ans_fbk> description

0 -8 = Frame Tunneling Mode is not selected.

9 = Initiate Frame Tunneling Mode when connection is completed, and Data State is entered.

Example 1: Normal Analog Modem

If AT+ISP=2, the POTS connection is selected and the +ES command is ignored. The modem is configured to non-pass-through mode and will perform normal analog modulation (i.e., PCM with A-Law or u-Law encoding).

Example 2: ISDN Data Pass-Through

If AT+ISP=0 or 1, the 64 kbps (0) or 56 kbps (1) pass-through mode is selected and the +ES command is used. To select frame tunneling, +ES <orig_rqst> parameter set to 7 and <ans_fbk> parameter set to 9 must be specified. If parameters other than <orig_rqst> parameter set to 7 and <ans_fbk> parameter set to 9 are specified, the modem is configured to pass-through mode without frame tunneling..

3.7.3 #CID Command - Multi-Frequency (MF) Tone Detection

Multi-Frequency (MF) Tone Detection can be enabled or disabled using the #CID command:

#CID=0 Disables Multi-Frequency (MF) Tone Detection

#CID=1 Enables Multi-Frequency(MF) Tone Detection

In Off-Line Command Mode (i.e., when the modem is idle), the #CID=1 command enables the modem to output the Received MF Digit Code for each valid MF Tone Pair received in accordance with Table 3-2.

AT Commands for Central Site Modems Reference Manual

For example, if MF Tone Pair 1300 Hz and 1500 Hz is detected, the modem will output 30h (ASCII 0) in the Receive Buffer Register (RBR) of the 16550 Parallel Host Interface.

The #CID=0 command should be issued whenever Multi-Frequency (MF) Tone Detection is not being used (i.e., before issuing the ATA or ATD commands).

Table 3-2. Received Multi-Frequency (MF) Tone Code

Received MF Digit Code	Low Frequency (Hz)	High Frequency (Hz)
ASCII 0 = 30h	1300	1500
ASCII 1 = 31h	700	900
ASCII 2 = 32h	700	1100
ASCII 3 = 33h	900	1100
ASCII 4 = 34h	700	1300
ASCII 5 = 35h	900	1300
ASCII 6 = 36h	1100	1300
ASCII 7 = 37h	700	1500
ASCII 7 = 38h	900	1500
ASCII 9 = 39h	1100	1500
ASCII A = 41h	700	1700
ASCII B = 42h	900	1700
ASCII C = 43h	1100	1700
ASCII D = 44h	1300	1700
ASCII E = 45h	1500	1700

AT Commands for Central Site Modems Reference Manual

3.7.4 ISDN PPP Connection Support

Frame Tunneling Support (Async-HDLC) per RFC 1662 for ISDN PPP Connections

In Pass-Through Mode with Frame Tunneling (i.e. +ISP=0 or 1, and +ES=7,0,9), the modem supports the Physical Layer Requirements described in RFC 1662, Section 2. Specifically, "... a full-duplex circuit, either dedicated or circuit-switched, which can operate in an asynchronous (start/stop) mode, transparent to PPP Data Link Layer frames".

The modem is "transparent to PPP Data Link Layer frames", because of the "Octet Stuffing Procedure" described in RFC 1662, Section 4.2.

The Octet Stuffing Procedure defines 2 special bytes: 7Eh is the HDLC Flag, and 7Dh is the Control Escape Octet.

Sending HDLC Frames

The modem searches for the combination "7D nn" in the Tx Data Byte stream from the Host, this combination represents the data byte "nn" XORed with 20h. (e.g. "7D 5E" represents 7E as data). There is also a special case: "7D 7E" which means ABORT.

When the modem finds a "7E", that is not preceded by a "7D", it marks the start/end of an HDLC frame (since "7E" as data is sent as "7D 5E"). All bytes following a "7E" are interpreted as data for this HDLC frame, until another "7E" is found.

The modem deletes all "7D" bytes (Control Escape Octet) in the Tx Data Byte stream from the Host. The byte following a "7D" is checked for "7E" (ABORT). If the byte following a "7D" is not "7E", then the byte is XORed with 20h, before being included in the HDLC frame.

Receiving HDLC Frames

The modem outputs a "7E" to the Host to indicate the start/end of an HDLC frame. It then searches the Rx Data Byte stream for "7E", "7D", or any byte in the range "00" to "1F". If a "7E", "7D", or any byte in the range "00" to "1F", is found, the modem outputs a "7D" to the Host, and XORs the data byte with 20h, before outputting it to the Host. All bytes other than "7E", "7D", or any byte in the range "00" to "1F", are output directly to the Host.

The modem supports the Asynchronous to Synchronous Conversion requirements described in RFC 1662, Section 6. Specifically, "... the responsibility of the converter to do all (octet) stuffing conversions during operation."

The Async-Control-Character-Map (ACCM) Configuration Option, described in RFC 1662, Section 7, is not supported by the modem.

3.7.5 +TSA Command - Program the Time Slot Assignment

The +TSA command allows the time slot number to be programmed from 0 to 127. The command also allows TXDATA output to be enabled when off-hook and a time slot occurs, or to be forced to tristate even in off-hook mode.

The command syntax is:

+TSA=XXX,Y

where:

XXX = the time slot number (0-127).

Note: Each time slot requires 8 CLKs. Therefore, to use slot 127, the CLK rate must be 8.192 MHz, as follows: (128 slots x 8 CLKs per slot) x 8 kHz frame rate = 8.192 MHz

Y selects TXDATA tri-state option:

Y=1 Enables TXDATA output when off-hook, and time slot occurs.

Y=0 Forces TXDATA output to tri-state, even in off-hook mode.

Note: TXDATA output is always tri-state in on-hook mode (i.e. Idle mode).

Example 1: AT+TSA=127,1 Modem is set for slot 127 and TXDATA output is enabled when off-hook.

Example 2: AT+TSA=5,0 Modem is set for slot 5 and TXDATA output is forced to tri-state always.

AT Commands for Central Site Modems Reference Manual

3.7.6 &V2 - Modem Status Reporting

&V2 reports a string that contains a modem status report. By setting bit 4 of S202 (i.e., S202=16), the modem status string will automatically display before every connect message and after each hang-up (before the 'NO CARRIER' message). The string is organized in the following manner:

```
BEGINaa26ab26ac26ad26ba11bb64 ... pa18END
```

Where:

1. The only capitalized letters are BEGIN and END, signifying the start and stop of the message.
2. The only small letters are for fields described later.
3. The only numbers are the values of the fields.
4. All values are initialized to 255 with the exception of 'pa' which is initialized to 21. This is done on power up, on ATZ, and on start of each handshake .

&V2 Command Fields

Field Code	Field Name	Notes
aa	Current transmit speed	
ab	Minimum transmit speed	
ac	Maximum transmit speed	
ba	Current receive speed	
bb	Minimum receive speed	
bc	Maximum receive speed	
ca	Error correction protocol	
cb	Compression type	
cc	Modulation	
da	Symbol rate	
ea	Transmit carrier frequency	
eb	Receive carrier frequency	
fa	Last AGC gain value	
ga	Transmit level	
gb	Transmit Level Reduction	
ha	Last EQM value	
hb	Minimum EQM value	
hc	Maximum EQM value	
hd	Number of EQM hits	
ia	SNR ratio	
ib	Minimum SNR value	
ic	Maximum SNR value	
ja	Number of local retrains	
jb	Number of remote retrains	
jc	Number of local rate renegs	
jd	Number of remote rate renegs	
ka	Transmit Non-linear Encoding	
kb	Receive Non-linear Encoding	
kc	Transmit precoding	
kd	Receive precoding	
ke	Transmit shaping	
kf	Receive shaping	
kg	Trellis mapping	
kh	Pre-emphasis	
ki	Upper band edge	

AT Commands for Central Site Modems Reference Manual

kj	Lower band edge	
kk	Round trip delay high byte	
kl	Round trip delay low byte	
la	Highest transmit state	
lb	Highest receive state	
ma	Connection time (Hours)	
mb	Connection time (Minutes)	
mc	Connection time (Seconds)	
na	Auto gain amplitude	
nb	Auto gain attenuation	
oa	Dual PCM and 120 Hz detection	Client only
ob	Digital impairments high byte	Client only
oc	Digital impairments low byte	Client only
oa	Digital Pad Detected	Server only
ob	RBS Pattern	Server only
oc	Rate drop due to RBS	Server only
pa	Disconnect reason	

Description of the fields and tables to decode the values for US profile

Note: (other profiles are not taken into account)

Field Code	Field Name	Notes
aa	Current transmit speed	
ab	Minimum transmit speed	
ac	Maximum transmit speed	
ba	Current receive speed	
bb	Minimum receive speed	
bc	Maximum receive speed	

AT Commands for Central Site Modems Reference Manual

These fields display the data rates. The speeds all use the same table. These speeds can be decoded using the following table.

Speed	Value
0-300	0
600	1
1200	2
2400	3
4800	4
9600	5
12000	6
14400	7
7200	8
16800	9
19200	10
21600	11
24000	12
26400	13
28800	14
31200	15
33600	16
32000	17
34000	18
36000	19
38000	20
40000	21
42000	22
44000	23
46000	24
48000	25
50000	26
52000	27
54000	28
56000	29

ca *Error correction protocol*

This field displays the type of error correction chosen.

Protocol	Value
NONE	70
LAP-M	77
MNP4	80
MNP10 with cellular	81

AT Commands for Central Site Modems Reference Manual

cb *Compression type*

This field displays the type of compression chosen.

Compression	Value
NONE	69
MNP 5	66
V.42 bis	67

cc *Modulation*

This field displays the modulation type chosen, i.e., the DDP CONF value (see DDP designer's guide).

Modulation	Value
V.34	192-206
V.17	177-184
V.23	161-164
V.21	160 or 168
K56flex (K56Plus)	144-157
V.22 bis	130-132
V.32	112-120
Bell 212	98
Bell 103	96
V.22	81-82
V.FC	64-76
V.33	49-56
Bell 208	35
V.29	17-20
V.27	1-2

da *Symbol rate*

This field is only for V.34 and K56flex connections. All other connections see data pump manual for symbol rate.

Symbol Rate	Value
2400	0
2800	2
3000	3
3200	4
3429	5

AT Commands for Central Site Modems Reference Manual

ea *Transmit carrier frequency*

eb *Receive carrier frequency*

These fields are only for V.34 connections. All other connections see data pump manual for the carrier frequency. A one signifies the high frequency and a zero signifies the low frequency. These are dependent on the symbol rate which can be found in field "ea".

Symbol Rate	High Frequency (Hz)	Low Frequency (Hz)
2400	1800	1600
2800	1867	1680
3000	2000	1800
3200	1920	1829
3429	1959	1959

fa *Last AGC gain value*

This field displays the decimal value of the AGC gain high byte. This value can be used to calculate the Receive level with the following calculation.

Configuration	Calculation
K56flex, V.34, V.33, V.17, V.29, V.27	RL = N/2.7 - 52 dB
V.32 bis, V.32	RL = N/2.7 - 53 dB
V.22 bis, V.22, Bell 212, V.23/1200	RL = N/2.7 - 48 dB
V.21, V.23/75	RL = N/2.7 - 54 dB
Bell 103	RL = N/2.7 - 51 dB
* Where: N is the number displayed	

ga *Transmit level*

This field displays the transmit level based on S91 and offset.

$$\text{Formula: Transmit Level} = \text{S91} - (\text{\$A48})$$

The value given is in negative dB's.

gb *Transmit Level Reduction*

This field indicates the transmit level reduction as requested by the remote modem.

ha *Last EQM value*

hb *Minimum EQM value*

hc *Maximum EQM value*

These fields display the values from the last, maximum and minimum EQM readings.

hd *Number of EQM hits*

This field will display the number times EQM values became larger than \$7F. This condition will cause a rate renegotiation.

AT Commands for Central Site Modems Reference Manual

ia **SNR ratio**

ib **Minimum SNR value**

ic **Maximum SNR value**

These fields display the SNR values obtained during the V.34 probe. It needs to be converted in the following manner:

$$\text{SNR in dB} = 1.7 (X) - 7 \quad ; \text{ where X is the value displayed}$$

ja **Number of local retrains**

jb **Number of remote retrains**

These fields display the number of retrains which occurred during the connection.

jc **Number of local rate renegotiations**

jd **Number of remote rate renegotiations**

These fields display the number of rate renegotiations which occurred during the connection.

ka **Transmit non-linear Encoding (Warping)**

kb **Receive non-linear Encoding**

These fields display a one if non-linear encoding is on and a zero if non-linear encoding is off.

kc **Transmit precoding**

kd **Receive precoding**

These fields display a one if precoding is on and a zero if precoding is off.

ke **Transmit shaping**

kf **Receive shaping**

These fields display a sixteen if shaping is on and a zero if shaping is off.

kg **Trellis mapping**

This field displays the number of type of trellis mapping used.

Trellis Mapping	Value
16 state	0
32 state	8
64 state	24

kh **Pre-emphasis**

This field displays the number of the pre-emphasis filter chosen during the call. The value will be between 0 and 10.

ki **Upper band edge**

kj **Lower band edge**

These fields display the upper and lower band edges. The values need to be converted using the following equations:

$$\text{Lower -3dB edge (Hz)} = 37.5(X) + 150$$

$$\text{Upper -3dB edge (Hz)} = 37.5(X) + 2400$$

Where: X is the decimal value displayed.

AT Commands for Central Site Modems Reference Manual

kk Round trip delay high byte

kl Round trip delay low byte

These fields display the values needed to calculate the round trip delay using the following calculation:

$$RTD = (N / X) - 3.5 \text{ (for V.34, K56flex, and V.FC)}$$

$$RTD = (N / 2.4) - 29 \text{ (for V.32 bis)}$$

Where:

RTD is the round trip delay in ms

N is the decimal value of the 16 bit word achieved by the combination of the hex values of the two fields.

Example: kk32kl127 converts 32 to 20h and 127 to 7Fh to get the 16-bit word 207Fh. Now convert this to its decimal equivalent 8319 and this is the value of N.

X is the symbol rate found in the field 'ea' divided by 1000

la Highest transmit state

lb Highest receive state

These fields display the highest transmit and receive SPX states reached. A description of these states can be found in the DDP designer's guide. The values must be changed to hex format.

ma Connection time (Hours)

mb Connection time (Minutes)

mc Connection time (Seconds)

These fields combine to give the total time of connection.

na Auto gain amplitude

This field displays the auto gain value chosen for the connection. The value is determined by the following table.

Auto Gain (dB)	Value
0	0
10	2
15	4
20	6

nb Auto gain attenuation

This field displays the auto gain attenuation. The amount attenuated can be found using the following table.

Attenuation (dB)	Value
0	0
4	16

oa Dual PCM and 120 Hz detection (for client only)

This field indicates if dual PCM and/or 120 Hz tones were detected.

Convert this value to its hex value.

If bit 0 is set then 120 Hz tones were detected; .

If bit 1 is set then dual PCM was detected.

AT Commands for Central Site Modems Reference Manual

ob *Digital impairments high byte (for client only)*

oc *Digital impairments low byte (for client only)*

These fields display the digital impairments found during the connection.

These fields need to be converted into a 16-bit hex word.

Example: oa32ob127... convert 32 to 20h and 127 to 7Fh to get the 16 bit word 207Fh.

- Bits 0-5: Show the RBS pattern detected before pad.
- Bit 6: If set, ½ RBS detected; if reset, ½ RBS not detected
- Bits 8-D: RBS pattern detected after pad
- Bits E-F: shows the digital pad detected

Bit F	Bit E	Pad
0	0	None
0	1	3dB
1	0	6dB

ob *Digital Pad Detected (for Server only)*

This field displays the digital pad found during the connection.

These fields need to be converted into its hex equivalent.

The digital pad is detected using the following table:

Bit 7	Bit 6	Pad
0	0	None
0	1	3 dB
1	0	6 dB

ob *RBS Pattern (for Server only)*

This field displays the total RBS pattern found during the connection.

This needs to be converted to its hex equivalent and the lower six bits display the pattern. Bits 6 and 7 are not used.

oc *Rate drop due to RBS (for Server only)*

This field displays the rate dropped due to RBS (in Kbps).

AT Commands for Central Site Modems Reference Manual

pa Disconnect reason

This field displays a code which describes the reason for disconnection. The values can be decoded using the following table:

Disconnect Reason	Value
LOCAL REQUEST	0
LOCAL REQUEST	1
LOCAL REQUEST	2
CALL WAITING	3
CARRIER LOSS	4
NO ERROR CORRECTION	5
NO ERROR CORRECTION	6
INCOMPATIBLE PROTOCOL	7
INCOMPATIBLE PROTOCOL	8
INCOMPATIBLE PROTOCOL	9
INCOMPATIBLE PROTOCOL	10
INCOMPATIBLE PROTOCOL	11
LINK DISCONNECT	12
EXCESSIVE RETRANSMISSIONS	13
INCOMPATIBLE PROTOCOL	14
DTR LOSS	15
GSTN CLEARDOWN	16
INACTIVITY TIMER	17
INCOMPATIBLE SPEEDS	18
BREAK DISCONNECT	19
KEY ABORT	20
NONE	21
NO CONNECT	22
3 RETRAINS	23

3.7.7 S202 - CSM Bit Mapped Control Register

Controls K56flex Tx level and automatic modem status response.

Default: 0 (00h)

- Bits 0-3 Reserved
- Bit 4 Automatic modem status response
 - 0 = No automatic modem status response (requires &V2 command) (Default.)
 - 1 = Automatic modem status response before every connect message and after every disconnect message
- Bit 5 K56flex Tx level select
 - 0 = -12 dBm (Default.)
 - 1 = - 6 dBm
- Bits 6-7 Reserved

4. S-REGISTERS

The S-Registers are summarized in Table 4-1 along with their default values; registers denoted with an '*' may be stored in one of the two user profiles by entering the &Wn command. One of these profiles may be loaded at any time by using the Zn command. Registers or register fields quoted as "reserved" are reserved for current or future use by the firmware, or are permanently overridden by PTT limitations. For the latter, control of the equivalent functionality is available with ConfigurACE Call Progress and Blacklisting options.

All bit-mapped registers are read-only. The appropriate AT command which controls the relevant bits in the S-Register should be used to change the value.

4.1 FACTORY DEFAULTS

The factory default values are stored in ROM and are loaded into the active configuration at power up or by the ATZn command. In addition, the designated default profile is subsequently loaded, and may change some of the factory default values. The designated default profile can be changed by entering the &Yn command where n is one of the two possible user profiles.

The defaults shown are those used by Rockwell in factory profiles zero and one. These may be overwritten by the OEM with ConfigurACE prior to placing the firmware in PROM. Minimum and maximum values may also be imposed by ConfigurACE in response to country PTT requirements.

The default values shown in Table 4-1 may vary by modem firmware configuration. Consult the MCU firmware release notes for exact configuration.

The factory default values may be loaded at any time by entering the &Fn command.

AT Commands for Central Site Modems Reference Manual

Table 4-1. S-Register Summary

Register	Function	Range	Units	Saved	Default**
S0	Rings to Auto-Answer	0-255	rings	*	0
S1	Ring Counter	0-255	rings		0
S2	Escape Character	0-255	ASCII	*	43
S3	Carriage Return Character	0-127	ASCII		13
S4	Line Feed Character	0-127	ASCII		10
S5	Backspace Character	0-255	ASCII		8
S6	Wait Time for Dial Tone	2-255	s	*	2
S7	Wait Time for Carrier	1-255	s	*	50
S8	Pause Time for Dial Delay Modifier	0-255	s	*	2
S9	Carrier Detect Response Time	1-255	0.1 s	*	6
S10	Carrier Loss Disconnect Time	1-255	0.1 s	*	14
S11	DTMF Tone Duration	50-255	0.001 s	*	95
S12	Escape Prompt Delay	0-255	0.02 s	*	50
S13	Reserved	-	-		-
S14	General Bit Mapped Options Status	-	-	*	138 (8Ah)
S15	Reserved	-	-		-
S16	Test Mode Bit Mapped Options Status (&T)	-	-		0
S17	Reserved	-	-		-
S18	Test Timer	0-255	s	*	0
S19	AutoSync Options	-	-		0
S20	AutoSync HDLC Address or BSC Sync Character	0-255	-	*	0
S21	V.24/General Bit Mapped Options Status	-	-	*	52 (34h)
S22	Speaker/Results Bit Mapped Options Status	-	-	*	117 (75h)
S23	General Bit Mapped Options Status		-	*	62 (3Dh)
S24	Sleep Inactivity Timer	0-255	s	*	0
S25	Delay to DTR Off	0-255	s or 0.01 s		5
S26	RTS-to-CTS Delay	0-255	0.01 s		1
S27	General Bit Mapped Options Status	-	-	*	73 (49h)
S28	General Bit-Mapped Options Status	-	-	*	0
S29	Flash Dial Modifier Time	0-255	10 ms		70
S30	Disconnect Inactivity Timer	0-255	10 s		0
S31	General Bit-Mapped Options Status	-	-	*	194 (C2h)
S32	XON Character	0-255	ASCII		17 (11h)
S33	XOFF Character	0-255	ASCII		19 (13h)
S34-S35	Reserved	-	-		-
S36	LAPM Failure Control	-	-	*	7
S37	Line Connection Speed	-	-	*	0
S38	Delay Before Forced Hangup	0-255	s		20
S39	Flow Control Bit Mapped Options Status	-	-	*	3

AT Commands for Central Site Modems Reference Manual

Table 4-1. S-Register Summary (Cont'd)

Register	Function	Range	Units	Saved	Default**
S40	General Bit-Mapped Options Status	-	-	*	104 (68h)
S41	General Bit-Mapped Options Status	-	-	*	195 (C3h)
S42-S45	Reserved	-	-		-
S46	Data Compression Control	-	-	*	138
S48	V.42 Negotiation Control	-	-	*	7
S82	LAPM Break Control	-	-		128(40h)
S86	Call Failure Reason Code	0-255	-		-
S91	PSTN Transmit Attenuation Level	0-15	dBm		10 (Country dependent)
S92	Fax Transmit Attenuation Level	0-15	dBm		10 (Country dependent)
S95	Result Code Messages Control	-	-	*	0

* Register value may be stored in one of two user profiles with the &W command.
 ** Default values may be modified using ConfigurACE.

AT Commands for Central Site Modems Reference Manual

4.2 S-REGISTER DEFINITIONS

S0 - Number of Rings to Auto-Answer

Sets the number of the rings required before the modem automatically answers a call. Setting this register to zero disables auto-answer mode.

Range: 0-255 rings

Default: 0

S1 - Ring Counter

S1 is incremented each time the modem detects a ring signal on the telephone line. S1 is cleared if no rings occur over an eight second interval.

Range: 0-255 rings

Default: 0

S2 - Escape Character

S2 holds the decimal value of the ASCII character used as the escape character. The default value corresponds to an ASCII '+'. A value over 127 disables the escape process, i.e., no escape character will be recognized.

Range: 0-255, ASCII decimal

Default: 43 (+)

S3 - Carriage Return Character

Sets the command line and result code terminator character. Pertains to asynchronous operation only.

Range: 0-127, ASCII decimal

Default: 13 (Carriage Return)

S4 - Line Feed Character

Sets the character recognized as a line feed. Pertains to asynchronous operation only. The Line Feed control character is output after the Carriage Return control character if verbose result codes are used.

Range: 0-127, ASCII decimal

Default: 10 (Line Feed)

S5 - Backspace Character

Sets the character recognized as a backspace. Pertains to asynchronous operation only. The modem will not recognize the Backspace character if it is set to a value that is greater than 32 ASCII. This character can be used to edit a command line. When the echo command is enabled, the modem echoes back to the local DTE the Backspace character, an ASCII space character and a second Backspace character; this means a total of three characters are transmitted each time the modem processes the Backspace character.

Range: 0-32, ASCII decimal

Default: 8 (Backspace)

AT Commands for Central Site Modems Reference Manual

S6 - Wait Time for Dial Tone Before Blind Dialing, or After “W” Dial Modifier (W-Class Models)

1. Sets the length of time, in seconds, that the modem will wait before starting to dial after going off-hook when blind dialing. This operation, however, may be affected by some ATX options according to country restrictions. The “Wait for Dial Tone” call progress feature (W dial modifier in the dial string) will override the value in register S6.
2. For W-class models, S6 sets the length of time, in seconds, that the modem will wait for dial tone when encountering a “W” dial modifier before returning NO DIAL TONE result code.

The modem always pauses for a minimum of 2 seconds, even if the value of S6 is less than 2 seconds.

Range: 2-255 seconds

Default: 2

S7 - Wait Time For Carrier After Dial, For Silence, or For Dial Tone After “W” Dial Modifier (US Models)

1. Sets the length of time, in seconds, that the modem will wait for carrier before hanging up. The timer is started when the modem finishes dialing (originate), or 2 seconds after going off-hook (answer). In originate mode, the timer is reset upon detection of answer tone if allowed by country restrictions.
2. Sets the length of time, in seconds, that modem will wait for silence when encountering the @ dial modifier before continuing with the next dial string parameter.
3. For US models, S7 sets the length of time, in seconds, that the modem will wait for dial tone when encountering a “W” dial modifier before continuing with the next dial string parameter.

Range: 1-255 seconds

Default: 50

S8 - Pause Time For Dial Delay

Sets the time, in seconds, that the modem must pause when the “,” dial modifier is encountered in the dial string.

Range: 0-255 seconds

Default: 2

S9 - Carrier Detect Response Time

Sets the time, in tenths of a second, that the carrier must be present before the modem considers it valid and turns on RLSD. As this time is increased, there is less chance to detect a false carrier due to noise from the telephone line.

Range: 1-255 tenths of a second

Default: 6 (0.6 second)

S10 - Lost Carrier To Hang Up Delay

Sets the length of time, in tenths of a second, that the modem waits before hanging up after a loss of carrier. This allows for a temporary carrier loss without causing the local modem to disconnect. When register S10 is set to 255, the modem functions as if a carrier is always present.

The actual interval the modem waits before disconnecting is the value in register S10 minus the value in register S9.

Therefore, the S10 value must be greater than the S9 value or else the modem disconnects before it recognizes the carrier.

Range: 1-255 tenths of a second

Default: 14 (1.4 seconds)

S11 - DTMF Tone Duration

Sets the duration of tones in DTMF dialing (US models only). This value has no effect on pulse dialing.

For W-class models, this parameter is a country parameter loaded by ConfigurACE.

Range: 50-255 milliseconds

Default: 95 (95 milliseconds)

AT Commands for Central Site Modems Reference Manual

S12 - Escape Prompt Delay (EPD)

Defines the maximum period, in fiftieths of a second, allowed between receipt of the last character of the three escape character sequence from the DTE and sending of the OK result code to the DTE. If any characters are detected during this time, the OK will not be sent. Note that sending of the OK result code does not affect entry into command mode. (See 3.1.3.)

Range: 0-255 1/50 of a second

Default: 50 (1 second)

S13 - Reserved

S14 - General Bit Mapped Options Status

Indicates the status of command options.

Default: 138 (8Ah) (10001010b)

Bit 0	This bit is ignored.
Bit 1	Command echo (En) 0 = Disabled (E0) 1 = Enabled (E1) (Default.)
Bit 2	Quiet mode (Qn) 0 = Send result codes (Q0) (Default.) 1 = Do not send result codes (Q1)
Bit 3	Result codes (Vn) 0 = Numeric (V0) 1 = Verbose (V1) (Default.)
Bit 4	Reserved
Bit 5	Tone (T)/Pulse (P) 0 = Tone (T) (Default.) 1 = Pulse (P)
Bit 6	Reserved
Bit 7	Originate/Answer 0 = Answer 1 = Originate (Default.)

S15 - Reserved

AT Commands for Central Site Modems Reference Manual

S16 - General Bit Mapped Test Options Status

Indicates the test in progress status.

Default: 0

Bit 0	Local analog loopback
	0 = Disabled (Default.)
	1 = Enabled (&T1)
Bit 1	Not used
Bit 2	Local digital loopback
	0 = Disabled (Default.)
	1 = Enabled (&T3)
Bit 3	Remote digital loopback (RDL) status
	0 = Modem not in RDL (Default.)
	1 = RDL in progress
Bit 4	RDL requested (AT&T6)
	0 = RDL not requested (Default.)
	1 = RDL requested (&T6)
Bit 5	RDL with self test
	0 = Disabled (Default.)
	1 = Enabled (&T7)
Bit 6	Local analog loopback (LAL) with self test
	0 = Disabled (Default.)
	1 = Enabled (&T8)
Bit 7	Not used

S17 - Reserved

S18 - Test Timer

Sets the length of time, in seconds, that the modem conducts a test (commanded by &Tn) before returning to the command mode. If this register value is zero, the test will not automatically terminate; the test must be terminated from the command mode by issuing an &T0 or H command. When S18 is non-zero, the modem returns the OK message upon test termination.

Range: 0-255 seconds

Default: 0

AT Commands for Central Site Modems Reference Manual

S19 - AutoSync Bit Mapped Options

Defines the options for AutoSync operation (see &Q4 command). S19 must be set to the desired value before &Q4 is issued.

Default: 0

Bit 0	Reserved
Bit 1	BSC/HDLC format select
	0 = BSC selected (Default.)
	1 = HDLC selected
Bit 2	Address detection enable/disable
	0 = Disabled (Default.)
	1 = Enabled
Bit 3	NRZI/NZI coding select
	0 = NRZI (Default.)
	1 = NZI
Bit 4	Idle indicator select
	0 = Mark idle (Default.)
	1 = Flag or sync idle
Bits 5 - 7	Reserved

S20 - AutoSync HDLC Address or BSC Sync Character

Defines the HDLC address (S19 bit 1 = 1) or BSC Sync Character (S19 bit 1 = 0) for AutoSync operation (see &Q4 command). S20 must be set to the desired value before &Q4 is issued.

Range: 0-255

Default: 0

AT Commands for Central Site Modems Reference Manual

S21 - V.24/General Bit Mapped Options Status

Indicates the status of command options.

Default: 52 (34h) (00110100b)

Bit 0	Set by &Jn command but ignored otherwise. 0 = &J0 (Default.) 1 = &J1
Bit 1	Reserved
Bit 2	CTS behavior (&Rn) 0 = CTS tracks RTS (&R0) 1 = CTS always on (&R1) (Default.)
Bits 3-4	DTR behavior (&Dn) 0 = &D0 selected 1 = &D1 selected 2 = &D2 selected (Default.) 3 = &D3 selected
Bit 5	RLSD (DCD) behavior (&Cn) 0 = &C0 selected 1 = &C1 selected (Default.)
Bit 6	DSR behavior (&Sn) 0 = &S0 selected (Default.) 1 = &S1 selected
Bit 7	Long space disconnect (Yn) 0 = Y0 (Default.) 1 = Y1

AT Commands for Central Site Modems Reference Manual

S22 - Speaker/Results Bit Mapped Options Status

Indicates the status of command options.

Default: 117 (75h) (01110101b)

Bits 0-1	Speaker volume (Ln)
	0 = Off (L0)
	1 = Low (L1) (Default.)
	2 = Medium (L2)
	3 = High (L3)
Bits 2-3	Speaker control (Mn)
	0 = Disabled (M0)
	1 = Off on carrier (M1) (Default.)
	2 = Always on (M2)
	3 = On during handshake (M3)
Bits 4-6	Limit result codes (Xn)
	0 = X0
	4 = X1
	5 = X2
	6 = X3
	7 = X4 (Default.)
Bit 7	Reserved

AT Commands for Central Site Modems Reference Manual

S23 - General Bit Mapped Options Status

Indicates the status of command options.

Default: 62 (3Dh) (00111110b)

Bit 0	Grant RDL
	0 = RDL not allowed (&T5) (Default.)
	1 = RDL allowed (&T4)
Bits 1-3	DTE Rate
	0 = 0 - 300 bps
	1 = 600 bps
	2 = 1200 bps
	3 = 2400 bps
	4 = 4800 bps
	5 = 9600 bps
	6 = 19200 bps
	7 = 38400 bps or higher (Default.)
Bits 4-5	Assumed DTE parity
	0 = even
	1 = not used
	2 = odd
	3 = none (Default.)
Bits 6-7	Guard tone (&Gn)
	0 = None (&G0) (Default.)
	1 = None (&G1)
	2 = 1800 Hz (&G2)

S24 - Sleep Inactivity Timer

Sets the length of time, in seconds, that the modem will operate in normal mode with no detected telephone line or DTE line activity before entering low-power sleep mode. The timer is reset upon any DTE line or telephone line activity. If the S24 value is zero, neither DTE line nor telephone inactivity will cause the modem to enter the sleep mode.

Range: 0-255 seconds

Default: 0

S25 - Delay To DTR

Sets the length of time that the modem will ignore DTR for taking the action specified by &Dn. Its units are seconds for synchronous modes and one hundredths of a second for other modes.

Range: 0-255 (1 second for synchronous modes 1; 0.01 second otherwise)

Default: 5

S26 - RTS to CTS Delay

Sets the time delay, in hundredths of a second, before the modem turns CTS ON after detecting an OFF-to-ON transition on RTS when &R0 is commanded. Pertains to synchronous operation only.

Range: 0-255 hundredths of a second

Default: 1

AT Commands for Central Site Modems Reference Manual

S27 - Bit Mapped Options Status

Indicates the status of command options.

Default: 73 (49h) (01001001b)

Bits 0,1,3 Synchronous/asynchronous selection (&Mn/&Qn)

3 1 0

0 0 0 = &M0 or &Q0

0 0 1 = &M1 or &Q1

0 1 0 = &M2 or &Q2

0 1 1 = &M3 or &Q3

1 0 0 = &Q4

1 0 1 = &Q5 (Default.)

1 1 0 = &Q6

Bit 2 Leased line control (&Ln)

0 = Dial up line (&L0) (Default.)

Bits 4 - 5 Internal clock select (&Xn)

0 = Internal clock (&X0) (Default.)

1 = External clock (&X1)

2 = Slave clock (&X2)

Bit 6 CCITT/Bell mode select (Bn)

0 = CCITT mode (B0)

1 = Bell mode (B1) (Default.)

Bit 7 - Reserved

AT Commands for Central Site Modems Reference Manual

S28 - Bit Mapped Options Status

Default: 0

Bits 0 - 1	Reserved
Bit 2	Reserved (always 0).
Bits 3 - 4	Pulse dialing (&Pn) 0 = 39%-61% make/break ratio at 10 pulses per second (&P0) (Default.) 1 = 33%-67% make/break ratio at 10 pulses per second (&P1) 2 = 39%-61% make/break ratio at 20 pulses per second (&P2) 3 = 33%-67% make/break ratio at 20 pulses per second (&P3)
Bit 5-7	Reserved

S29 - Flash Dial Modifier Time

Sets the length of time, in units of 10 ms, that the modem will go on-hook when it encounters the flash (!) dial modifier in the dial string. The time can be limited as it is a country dependent parameter.

Range: 0-255 10 ms intervals

Default: 70 (700 ms)

S30 - Disconnect Inactivity Timer

Sets the length of time, in tens of seconds, that the modem will stay online before disconnecting when no data is sent or received. In error-correction mode, any data transmitted or received will reset the timer. In other modes, any data transmitted will reset the timer. The timer is inoperative in synchronous mode.

Range: 0-255 tens of seconds (0-2550 seconds)

Default: 0 (disabled)

AT Commands for Central Site Modems Reference Manual

S31 - Bit Mapped Options Status

Default: 194 (C2h) (11000010b)

Bit 0	Single line connect message enable/disable (\Vn) 0 = Messages controlled by S95, Wn and Vn (\V0) (Default) 1 = Single line connect message (\V1)
Bit 1	Auto line speed detection (Nn) 0 = Disabled (N0) 1 = Enabled (N1) (Default.)
Bits 2-3	Error correction progress messages (Wn) 0 = DTE speed only (W0) (Default) 1 = Full reporting (W1) 2 = DCE speed only (W2)
Bits 4-5	Caller ID (#CID) 0 = Caller ID disabled (#CID=0) (Default) 1 = Short (formatted) Caller ID enabled (#CID=1) 2 = Long (unformatted) Caller ID enabled (#CID=2)
Bits 6-7	Reserved (Default = 11b)

S32 - XON Character

Sets the value of the XON character.

Range: 0-255, ASCII decimal

Default: 17 (11h)

S33 - XOFF Character

Sets the value of the XOFF character.

Range: 0-255, ASCII decimal

Default: 19 (13h)

S34-S35 - Reserved

AT Commands for Central Site Modems Reference Manual

S36 - LAPM Failure Control

Default: 7 (00000111b)

Bits 0-2 This value indicates what should happen upon a LAPM failure. These fallback options are initiated immediately upon connection if S48=128. If an invalid number is entered, the number is accepted into the register, but S36 will act as if the default value has been entered.

0 = Modem disconnects.

1 = Modem stays on-line and a Direct mode connection is established.

2 = Reserved.

3 = Modem stays on-line and a Normal mode connection is established.

4 = An MNP connection is attempted and if it fails, the modem disconnects.

5 = An MNP connection is attempted and if it fails, a Direct mode connection is established.

6 = Reserved.

7 = An MNP connection is attempted and if it fails, a Normal mode connection is established. (Default.)

Bits 3-7 Reserved

AT Commands for Central Site Modems Reference Manual

S37 - Desired Line Connection Speed

This register specifies the desired line connection speed.

Notes:

1. When the Nn command is issued or the S37 register value is modified, the +MS command subparameters are updated to reflect the speed and modulation specified by the S37 value (see +MS command). For example:

If N0 command is active, S37=10 updates the +MS command subparameters to reflect +MS=10,1,300,12000

If N1 command is active, S37=10 updates the +MS command subparameters to reflect +MS=10,0,12000,12000

2. S37 is not updated by the +MS command.
3. Use of the +MS command is recommended instead of the Nn and S37=x commands. Nn and S37=x commands are supported for compatibility with existing communication software.

Default: 0

Bits 0-4	Desired line connection speed. If an invalid number is entered, the number is accepted into the register, but S37 will act as if the default value has been entered.
0 =	Attempt automode connection. If N0 is active, connection is attempted at the most recently sensed DTE speed (+MS command settings are updated to the appropriate values). If N1 is active, connection is attempted at the highest possible speed (e.g., +MS settings are updated to 11,1,300,33600 to reflect V.34, automode, 300 bps minimum speed, and 33600 bps maximum speed). (Default.)
1-3 =	Attempt to connect at 300 bps.
4 =	Reserved.
5 =	Attempt to connect at V.22 1200 bps.
6 =	Attempt to connect at V.22 bis 2400 bps.
7 =	Attempt to connect at V.23.
8 =	Attempt to connect at V.32 bis/V.32 4800 bps.
9 =	Attempt to connect at V.32 bis/V.32 9600 bps.
10 =	Attempt to connect at V.32 bis 12000 bps.
11 =	Attempt to connect at V.32 bis 14400 bps.
12 =	Attempt to connect at V.32 bis 7200 bps.
Bits 5-7	Reserved

AT Commands for Central Site Modems Reference Manual

S38 - Delay Before Forced Hang Up

This register specifies the delay between the modem's receipt of the H command to disconnect (or ON-to-OFF transition of DTR if the modem is programmed to follow the signal), and the disconnect operation. Applicable to error-correction connection only. This register can be used to ensure that data in the modem buffer is sent before the modem disconnects.

1. If S38 is set to a value between 0 and 254, the modem will wait that number of seconds for the remote modem to acknowledge all data in the modem buffer before disconnecting. If time expires before all data is sent, the NO CARRIER result code will be issued to indicate that data has been lost. If all data is transmitted prior to time-out, the response to the H0 command will be OK.
2. If S38 is set to 255, the modem does not time-out and continues to attempt to deliver data in the buffer until the connection is lost or the data is delivered.

Range: 0-255 seconds

Default: 20

S39 - Flow Control Bit Mapped Options Status

Default: 3 (00000011b)

Bits 0-2	Status of command options
	0 = No flow control
	3 = RTS/CTS (&K3) (Default.)
	4 = XON/XOFF (&K4)
	5 = Transparent XON (&K5)
	6 = Both methods (&K6)
Bits 3-7	Reserved

AT Commands for Central Site Modems Reference Manual

S40 - General Bit Mapped Options Status

Indicates the status of command options.

Default: 104 (68h) (01101000b)

Bits 0-1	MNP Extended Services (-Kn)
	0 = Disable extended services (-K0) (Default)
	1 = Enable extended services (-K1)
	2 = Enable extended services (-K2)
Bit 2	Reserved
Bits 3-5	Break Handling (\Kn)
	0 = \K0
	1 = \K1
	2 = \K2
	3 = \K3
	4 = \K4
	5 = \K5 (Default.)
Bits 6-7	MNP block size (\An)
	0 = 64 chars (\A0)
	1 = 128 chars (\A1) (Default.)
	2 = 192 chars (\A2)
	3 = 256 chars (\A3)

AT Commands for Central Site Modems Reference Manual

S41 - General Bit Mapped Options Status

Indicates the status of command options.

Default: 195 (C3h) (11000011b)

Bits 0 -1	Compression selection (%Cn)
	0 = Disabled (%C0)
	1 = MNP 5 (%C1)
	2 = V.42 bis (%C2)
	3 = MNP 5 and V.42 bis (%C3) (Default.)
Bits 2, 6	Auto retrain and fallback/fall forward (%En)
	Bit 6 Bit 2
	0 0 = Retrain and fallback/fall forward disabled (%E0)
	0 1 = Retrain enabled (%E1)
	1 0 = Fallback/fall forward enabled (%E2) (Default.)
Bit 3	Reserved
Bits 4-5	Reserved
Bit 7	Reserved

S46 - Data Compression Control

Controls selection of compression. The following actions are executed for the given values:

Range: 136 or 138

Default: 138

S46=136	Execute error correction protocol with no compression.
S46=138	Execute error correction protocol with compression. (Default.)

S48 - V.42 Negotiation Action

The V.42 negotiation process determines the capabilities of the remote modem. However, when the capabilities of the remote modem are known and negotiation is unnecessary, this process can be bypassed if so desired.

Range: 0, 7, or 128 If an invalid number is entered, it is accepted into the S-Register, but S48 will act as if 128 has been entered.

Default: 7

S48=0	Disable negotiation; bypass the detection and negotiation phases; and proceed with LAPM.
S48=7	Enable negotiation. (Default.)
S48=128	Disable negotiation; bypass the detection and negotiation phases; and proceed at once with the fallback action specified in S36. Can be used to force MNP.

AT Commands for Central Site Modems Reference Manual

S82 - Break Handling Options

S82 is for compatibility purposes only, changing this register will not have any affect.

S86 - Call Failure Reason Code

When the modem issues a NO CARRIER result code, a value is written to this S-Register to help determine the reason for the failed connection. S86 records the first event that contributes to a NO CARRIER message. The cause codes are:

Range: 0, 4, 5, 9, 12, 13, or 14

Default:

S86=0	Normal disconnect, no error occurred.
S86=4	Loss of carrier.
S86=5	V.42 negotiation failed to detect an error-correction modem at the other end.
S86=9	The modems could not find a common protocol.
S86=12	Normal disconnect initiated by the remote modem.
S86=13	Remote modem does not respond after 10 re-transmissions of the same message.
S86=14	Protocol violation.

S91 - PSTN Transmit Attenuation Level

Sets the transmit attenuation level from 0 to 15 dBm for the PSTN mode, resulting in a transmit level from 0 to -15 dBm. In some countries, the transmit level may not be changed and there are checks to prevent transmit attenuation level change using ConfigurACE.

Range: 0 to 15 dBm (Corresponding to 0 to -15 dBm transmit level.)

Default: 10 (-10 dBm transmit level.)

S92 - Fax Transmit Attenuation Level

Sets the transmit attenuation level from 0 to 15 dBm for the fax mode, resulting in a transmit level from 0 to -15 dBm. In some countries, the transmit level may not be changed and there are checks to prevent transmit attenuation level change using ConfigurACE.

Range: 0 to 15 dBm (Corresponding to 0 to -15 dBm transmit level.)

Default: 10 (-10 dBm transmit level.)

AT Commands for Central Site Modems Reference Manual

S95 - Extended Result Codes

The bits in this register can be set to override some of the Wn command options. A bit set to a 1 in this register will enable the corresponding result code regardless of the Wn setting. Also, refer to Table 3-1.

Default: 0

Bit 0	CONNECT result code indicates DCE speed instead of DTE speed.
Bit 1	Append/ARQ to CONNECT XXXX result code in error-correction mode (XXXX = rate; see Table 3-1).
Bit 2	Enable CARRIER XXXX result code (XXXX = rate; see Table 3-1).
Bit 3	Enable PROTOCOL XXXX result code (XXXX = protocol identifier; see Table 3-1).
Bit 4	Reserved.
Bit 5	Enable COMPRESSION result code (XXXX = compression type; see Table 3-1).
Bit 6	Reserved.
Bit 7	Reserved.

AT Commands for Central Site Modems Reference Manual

This page is intentionally blank.

5. FAX CLASS 1 COMMANDS

5.1 FAX I/O PROCESSING

The fax I/O interface supports asynchronous serial and parallel interfaces. The interface rate is 19200 bps. The character format is 8 bits data, no parity, and 1 stop bit. Start and stop elements are removed from the transmit data and added to the receive data. Both transmit and receive data are buffered. Flow control using XON/XOFF (DC1/DC3) or RTS/CTS is provided.

Unique control character strings are identified, filtered, or reinserted into the I/O data stream. These control characters and their resultant action are described below.

5.1.1 DTE-to-Modem Transmit Data Stream

Characters Detected	Action Taken
<DLE><data>	Delete <DLE><data> characters.
<DLE><ETX>	Recognize as a string terminator and take appropriate action.
<DLE><DLE>	Replace with single <DLE> character.

5.1.2 Modem-to-DTE Receive Data Stream

Characters Detected	Action Taken
<DLE>	Insert extra <DLE> ahead of <DLE>.

The modem also identifies the end of a frame by inserting <DLE><ETX> into the data stream after the FCS bytes.

5.1.3 Fax Mode Selection

Fax class 1 commands are identified in Table 5-1. Fax modes and rates are determined by the AT+F commands as described in Section 5.2.

Table 5-1. Fax Class 1 Commands

Command	Function
Service Class ID	
+FCLASS=	Service Class
Fax Class 1 Commands	
+FAE=n	Data/Fax Auto Answer
+FTS=n	Stop Transmission and Wait
+FRS=n	Receive Silence
+FTM=n	Transmit Data
+FRM=n	Receive Data
+FTH=n	Transmit Data with HDLC Framing
+FRH=n	Receive Data with HDLC Framing

5.1.4 Fax Origination

Origination of fax calls is made using the ATD command. Upon completion of the dial function, a calling tone at 1100 Hz is transmitted, with a cadence of 0.5 seconds on and 3 seconds off. The modem automatically enters mode +FRH=3 and sends the CONNECT message to the DTE when FSK flags are detected from the remote.

AT Commands for Central Site Modems Reference Manual

5.1.5 Fax Answering

Answering of fax calls is identical to answering of data calls with the exception that the modem enters the fax handshaking mode instead of the data handshaking mode after going off-hook. If +FAE=0, the modem, after sending answer tone, automatically enters fax mode (+FTH=3), sends the CONNECT message to the DTE, and starts sending FSK flags. If +FAE=1, the modem determines whether the caller is a data modem or fax modem and sends the DATA or FAX result code, respectively, to the DTE.

5.1.6 Fax Control Transmission

Fax control transmission is initiated by the +FTH=n command. After this command is issued, the modem generates the CONNECT message and transmits carrier in the modulation scheme specified by the parameter n. The modem then transmits HDLC flags for a minimum of 1 second. The modem continues to transmit the HDLC flags until it receives a character from the DTE.

When characters are received from the DTE, the modem adds start and end flags, performs zero-bit insertion, generates FCS, and deletes <DLE><chr> character pairs before transmitting the characters to the remote fax machine. Each <DLE><DLE> sequence is transmitted as a single <DLE>. <DLE><ETX> is considered as the end of frame marker and is not transmitted. All data received from the DTE after <DLE><ETX> is ignored by the modem until the modem generates either the CONNECT, OK, or ERROR result code.

If no more data is in the transmit buffer and the final bit was a 1 (bit 4 of the second byte received from the DTE), the modem generates the OK result code and returns to the command mode. If the final bit was a 0, the modem generates the CONNECT message and waits for further data from the DTE while transmitting HDLC flags. If no more data is received before 5 seconds elapse, the modem drops carrier, goes on-hook, and generates the ERROR result code.

5.1.7 Fax Control Reception

Fax control reception is initiated using the AT+FRH=n command. After this command is issued, the modem looks for carrier in the modulation scheme specified by the parameter n. If no carrier is detected before the period of time specified by register S7 expires, the modem generates the NO CARRIER message and returns to command mode. If a carrier is detected that is not the one specified by the parameter n, the modem generates the +FCERROR message and returns to the command mode. If the specified carrier is detected, the modem generates the CONNECT message and enters the HDLC receive mode.

In HDLC receive mode, the modem receives HDLC frames from the remote fax machine, strips the flags, performs zero-bit deletion, performs error checking, and handles <DLE><chr> character pairs before passing the data to the DTE. The modem prefixes each <DLE> character with another <DLE> character before sending it to the DTE. After the last byte in the frame, the modem sends <DLE><ETX> to the DTE marking the end of the frame. The modem then generates either the OK message if no errors were detected or the ERROR message if errors were detected (FCS is incorrect), and returns to command mode.

While in command mode, the modem continues to receive data in the selected modulation scheme, and sends the data after sending the CONNECT message to the DTE when the DTE reissues the +FRH command with the same parameter. If the DTE issues the +FRH command with a different parameter, the modem clears all buffers and proceeds as described previously.

If carrier is lost while in command mode and the DTE reissues the +FRH command with the same parameter, and there is no data in the buffer, the modem sends the ERROR result code to the DTE and returns to the command mode. If there is data in the buffer, the modem sends the next frame of buffered data to the DTE, followed by <DLE><ETX>, and either the ERROR result code if errors were detected or the OK result code if no errors were detected. The modem then returns to command mode.

The modem concludes an error is detected if carrier is lost for any period of time during or before the reception of a frame. If carrier is lost for a time period longer than the time specified by the register S10, the modem finishes delivering the data in the receive buffer (if any) to the DTE, sends <DLE><ETX>, generates the ERROR message, and returns to command mode. All subsequent data received from the remote is discarded.

If the modem detects a frame abort sequence (seven consecutive ones with no zero insertion) while it is waiting for a frame beginning flag (it was receiving HDLC flags), it will wait for the HDLC flags again until either carrier is lost, or the DTE aborts the process by sending an abort character or by dropping DTR with &D2 in effect. If the frame abort sequence is detected while the modem is receiving a frame it finishes delivering the data in the receive buffer (if any) to the DTE, sends

AT Commands for Central Site Modems Reference Manual

<DLE><ETX>, generates the ERROR message, and returns to command mode. The modem keeps looking for HDLC flags followed by more data from the remote, with the selected modulation scheme.

If the modem detects a receive buffer overflow condition, it concludes that there was an FCS error in that frame. The modem will receive more frames only if a starting flag is detected and there is room in the receive buffer. If a starting flag is detected and there is no room in the buffer, the modem discards all data in that frame.

If the modem receives any character from the DTE after the +FRH command (except flow control characters if software flow control is in effect), or if the modem detects a high-to-low transition of the DTR signal while &D1 is in effect, it sends <DLE><ETX> to the DTE, generates OK result code, and returns to command mode. The receive buffer is cleared and all data received from the remote is discarded. If the modem detects a DTR drop while &D2 is in effect, it goes on-hook, sends <DLE><ETX> to the DTE, generates OK result code, and returns to command mode. If the modem detects a DTR drop while &D3 is in effect, the modem performs a warm reset.

5.1.8 Fax Data Transmission

Fax data transmission is initiated by the AT+FTM=n command. After this command is issued, the modem generates the CONNECT message and transmits carrier in the modulation scheme specified by the parameter n. The modem then transmits constant 1 bits for a minimum of one second and continues to transmit constant 1 bits until it receives a character from the DTE.

When data is received from the DTE, the modem deletes start and stop bits and deletes all <DLE><chr> character pairs before transmitting the data to the remote. Each <DLE><DLE> sequence is transmitted as a single <DLE>. <DLE><ETX> is considered as the end of stream marker, and is not transmitted. All data received from the DTE after the <DLE><ETX> is ignored by the modem until the modem generates either the CONNECT, OK, or ERROR result code.

If no more data is in the transmit buffer, and the last transmitted character was not an ASCII NULL, the modem generates the OK result code and returns to the command mode. If the last character transmitted was an ASCII NULL, the modem generates the CONNECT message to the DTE and waits for further data from the DTE while transmitting NULLs to the remote. If more data is received before five seconds elapse, the modem continues to transmit the data as described in the previous paragraph. If five seconds elapse and no data is received from the DTE, the modem drops carrier, goes on-hook, and generates the ERROR result code.

5.1.9 Fax Data Reception

Fax data reception is initiated using the AT+FRM=n command. After this command is issued, the modem looks for carrier in the modulation scheme specified by the parameter n. If no carrier is detected before the period of time specified by register S7 expires, the modem generates the NO CARRIER message and returns to command mode. If a V.21 carrier is detected when a high speed carrier is expected, the modem generates the +FCERROR message and returns to the command mode. If the specified carrier is detected, the modem generates the CONNECT message and enters the data receive mode.

While in data receive mode, the modem receives data from the remote, adds start and stop bits, and handles <DLE><chr> character pairs before passing the data to the DTE. The modem prefixes each <DLE> character with another <DLE> character before sending it to the DTE.

If the modem detects a receive buffer overflow condition, it stops receiving from the remote until there is room in the receive buffer. The modem informs the DTE of the buffer overflow after it sends to the DTE the last character that was stored in the buffer before the overflow occurred.

If the modem receives any character from the DTE after the +FRM command (except flow control characters if software flow control is in effect), or if the modem detects a high-to-low transition of the DTR signal while &D1 is in effect, it sends <DLE><ETX> to the DTE, generates the OK result code, and returns to command mode. The receive buffer is cleared and all data received from the remote is discarded. If loss of DTR is detected while &D2 is in effect, the modem goes on-hook, sends <DLE><ETX> followed by OK result code to the DTE, and returns to command mode. If the modem detects a DTR drop while &D3 is in effect, the modem performs a warm reset.

AT Commands for Central Site Modems Reference Manual

5.2 COMMANDS

+FCLASS=n - Select Service Class

+FCLASS=n command sets the active service class.

Parameters: 0-2

Command options:

- +FCLASS=0 Select Data Mode (Default.)
- +FCLASS=1 Select Facsimile Class 1
- +FCLASS=2 Select Facsimile Class 2

+F<command>? - Report Active Configuration

+F<command>? interrogates the modem to determine the active configuration.

Typical responses are:

- +FAE? 0 if auto answer is disabled; 1 if auto answer is enabled
- +FCLASS? 0 if in data mode; 1 if in fax class 1; 2 if in fax class 2

+F<command>=? - Report Operating Capabilities

+F<command>=? can be used to determine the operating capabilities of the modem.

Typical responses are:

- +FAE=? 0 or 1
- +FCLASS=? 0, 1, or 2
- +FTM=? 24, 48, 72, 73, 74, 96, 97, 98, 121, 122, 145, 146
- +FRM=? 24, 48, 72, 73, 74, 96, 97, 98, 121, 122, 145, 146

+FAE=n - Data/Fax Auto Answer

+FAE=n allows the DTE to either restrict answering to class 1, or to automatically detect whether the calling station is a fax class 1 modem or data modem, and answer accordingly.

Parameters: n = 0 or 1

Command options:

- n = 0 Disable data/fax auto answer mode. The modem answers as a fax modem only. (Default.)
- n = 1 Enable data/fax auto answer mode. The modem answers as a fax or data modem.

After a data (not fax) connection is achieved (indicated by the DATA result code), the DTE must issue an ATO command to cause the modem to go on-line.

+FTS=n - Stop Transmission and Wait

+FTS=n causes the modem to terminate a transmission and wait for n 10-ms intervals before responding with the OK result code. An ERROR response code results if this command is issued while the modem is on-hook.

+FRS=n - Receive Silence

+FRS=n causes the modem to report back to the DTE with an OK result code after n 10 ms-intervals of silence have been detected on the line. This command is aborted if any character is received from the DTE. The modem discards the aborting character and issues an OK result code. An ERROR response code results if this command is issued while the modem is on-hook.

AT Commands for Central Site Modems Reference Manual

+FTM=n - Transmit Data

+FTM=n causes the modem to transmit data using the modulation defined below. An ERROR response code results if this command is issued while the modem is on-hook.

Parameters: See Command options

Command options:

+FTM=24	V.27 ter 2400 bps
+FTM=48	V.27 ter 4800 bps
+FTM=72	V.29 7200 bps
+FTM=73	V.17 7200 bps long
+FTM=74	V.17 7200 bps short
+FTM=96	V.29 9600 bps
+FTM=97	V.17 9600 bps long
+FTM=98	V.17 9600 bps short
+FTM=121	V.17 12000 bps long
+FTM=122	V.17 12000 bps short
+FTM=145	V.17 14400 bps long
+FTM=146	V.17 14400 bps short

+FRM=n - Receive Data

+FRM=n causes the modem to enter the receiver mode using the modulation defined below. An ERROR response code results if this command is issued while the modem is on-hook.

Parameters: See Command options

Command options:

+FRM=24	V.27 ter 2400 bps
+FRM=48	V.27 ter 4800 bps
+FRM=72	V.29 7200 bps
+FRM=73	V.17 7200 bps long
+FRM=74	V.17 7200 bps short
+FRM=96	V.29 9600 bps
+FRM=97	V.17 9600 bps long
+FRM=98	V.17 9600 bps short
+FRM=121	V.17 12000 bps long
+FRM=122	V.17 12000 bps short
+FRM=145	V.17 14400 bps long
+FRM=146	V.17 14400 bps short

AT Commands for Central Site Modems Reference Manual

+FTH=n - Transmit Data with HDLC Framing

+FTH=n causes the modem to transmit data using HDLC protocol and the modulation defined below. An ERROR response code results if this command is issued while the modem is on-hook.

Parameters: See Command options.

Command options:

+FTH=3	V.21 channel 2 300 bps
+FTH=24	V.27 ter 2400 bps
+FTH=48	V.27 ter 4800 bps
+FTH=72	V.29 7200 bps
+FTH=73	V.17 7200 bps long
+FTH=74	V.17 7200 bps short
+FTH=96	V.29 9600 bps
+FTH=97	V.17 9600 bps long
+FTH=98	V.17 9600 bps short
+FTH=121	V.17 12000 bps long
+FTH=122	V.17 12000 bps short
+FTH=145	V.17 14400 bps long
+FTH=146	V.17 14400 bps short

+FRH=n - Receive Data with HDLC Framing

+FRH=n causes the modem to receive frames using HDLC protocol and the modulation defined below. An ERROR response code results if this command is issued while the modem is on-hook.

Parameters: See Command options.

Command options:

+FTH=3	V.21 channel 2 300 bps
+FRH=24	V.27 ter 2400 bps
+FRH=48	V.27 ter 4800 bps
+FRH=72	V.29 7200 bps
+FRH=73	V.17 7200 bps long
+FRH=74	V.17 7200 bps short
+FRH=96	V.29 9600 bps
+FRH=97	V.17 9600 bps long
+FRH=98	V.17 9600 bps short
+FRH=121	V.17 12000 bps long
+FRH=122	V.17 12000 bps short
+FRH=145	V.17 14400 bps long
+FRH=146	V.17 14400 bps short

5.3 EXAMPLES

Examples of calling (transmitting) and answering (receiving) one page using fax class 1 commands are shown in Table 5-2 and Table 5-3, respectively.

AT Commands for Central Site Modems Reference Manual

Table 5-2. Fax Class 1 Calling Sequence (One Page)

DTE Commands (Host)	DCE Responses (Modem)	Remote Fax	Notes
(1) AT+FCLASS=1	(2) OK		Set to Class 1
PHASE A			
(3) ATDT6163	(4) Dials (6) CONNECT	(5) Answers (7) Send HDLC flags	+FRH=3 implied by dialing
PHASE B			
(10) AT+FRH=3	(9) <NSF>,OK (11) CONNECT	(8) Send NSF frame	
(14) AT+FRH=3	(13) <CSI>,OK (15) CONNECT	(12) Send CSI frame	
(19) AT+FTH=3	(17) <DIS>,OK (20) Send HDLC flags (21) CONNECT	(16) Send DIS frame (18) Drop carrier (21) Receive flags	Last frame bit = 1
(22) <TSI>	(23) Send TSI frame (25) CONNECT	(24) Receive TSI	Last frame bit = 0
(26) <DCS>	(27) Send DCS frame (29) Detect last frame bit (39) OK, drop carrier	(28) Receive DCS	Last frame bit = 1
(31) AT+FTS=8	(32) OK, wait 80 ms		
(33) AT+FTM=96	(34) Send V.29 (35) CONNECT		
(36) <TCF>	(37) Send TCF data (39) OK	(38) Receive & check	
(40) AT+FRH=3	(41) CONNECT (42) Send CFR frame		Last frame bit = 1
(43) <CFR>,OK	(44) Drop carrier (45) OK		
PHASE C			
(46) AT+FTM=96	(47) Send V.29 (48) CONNECT		
(49) age data	(50) Send page data (52) OK	(51) Receive data	
(53) AT+FTH=3	(54) Send HDLC flags (56) CONNECT	(55) Receive flags	
PHASE D			
(57) <EOP>	(58) Send EOP frame (60) OK, drop carrier	(59) Receive EOP	Last frame bit = 1
(61) AT+FRH=3	(62) CONNECT	(63) Send MCF frame	Last frame bit = 1
(65) AT+FTH=3	(64) <MCF>, OK (66) Send HDLC flags (68) CONNECT	(67) Receive flags	
(69) <DCN>	(70) Send DCN frame (72) OK, drop carrier	(71) Receive DCN	Last frame bit = 1
PHASE E			
(73) ATH0	(74) OK, hang up	(75) Hang up	

AT Commands for Central Site Modems Reference Manual

Table 5-3. Fax Class 1 Answering Sequence (One Page)

DTE Commands (Host)	DCE Responses (Modem)	Remote Fax	Notes
(1) AT+FCLASS=1	(2) OK		Set to Class 1
PHASE A			
		(3) FAX machine dials	
(5) ATA	(4) RING (6) Modem answers (7) Send HDLC flags	(8) Receive flags	+FTH=3 implied by answering
	(9) CONNECT		
PHASE B			
(10) <NSF>	(11) Send NSF frame (13) CONNECT	(12) Receive NSF	Last frame bit = 0
(14) <CSI>	(15) Send CSI frame (17) CONNECT	(16) Receive CSI	Last frame bit = 0
(18) <DIS>	(19) Send DIS frame (21) OK, drop carrier	(20) Receive DIS	Last frame bit = 1
(22) AT+FRH=3	(23) CONNECT		
	(25) <TSI>, OK	(24) Send TSI frame	Last frame bit = 0
(26) AT+FRH=3	(27) CONNECT		
	(29) <DCS>, OK	(28) Send DCS frame (30) Drop Carrier	Last frame bit = 1
(31) AT+FRM=96		(32) Send V.29	
	(33) CONNECT	(34) Send TCF frame	
	(35) <TCF>	(36) Drop carrier	
	(37) NO CARRIER		
(38) AT+FTH=3	(39) CONNECT		
(40) <CFR>	(41) Send CFR frame (43) OK, drop carrier	(42) Receive CFR	Last frame bit = 1
PHASE C			
(44) AT+FRM=96		(45) Send page data	
	(46) <page data>	(47) Drop carrier	
	(48) NO CARRIER		
PHASE D			
(49) AT+FRH=3	(50) CONNECT		
	(52) <EOP>, OK	(51) Send EOP frame	Last frame bit = 1
(53) AT+FTH=3	(54) CONNECT		
(55) <MCF>	(56) Send MCF frame (58) OK, drop carrier	(57) Receive MCF	Last frame bit = 1
(59) AT+FRH=3	(60) CONNECT		
	(62) <DCN>, OK	(61) Send DCN frame	Last frame bit = 1
PHASE E			
(73) ATH0	(74) OK, hang up	(75) Hang up	

6. FAX CLASS 2 COMMANDS

The fax class 2 commands are summarized in Table 6-1.

6.1 COMMAND SYNTAX AND GUIDELINES

6.1.1 DTE Commands

The ISO 646 character set (CCITT T.50 International Alphabet 5, American Standard Code for Information Interchange) is used for the issuance of commands and responses. Only the low-order 7 bits of each character are used for commands or parameters; the high order bit is ignored. Upper case characters are equivalent to lower case characters.

For Phase C data transmission or reception, all 8 bits are needed.

DTE Command Lines

A command line is a string of characters sent from a DTE to the modem (DCE) while the modem is in a command state. A command line has a prefix, a body, and a terminator. Each command line (with the exception of the A/ command) must begin with the character sequence AT and must be terminated by a carriage return. Commands entered in upper case or lower case are accepted, but both the A and T must be of the same case, i.e., "AT" = ASCII 065, 084 or "at" = ASCII 097, 116. The body is a string of commands restricted to printable ASCII characters (032 - 126). Space characters (ASCII 032) and control characters other than CR (ASCII 013) and BS (ASCII 010) in the command string are ignored. The default terminator is the ASCII <CR> character. Characters that precede the AT prefix are ignored. The command line interpretation begins upon receipt of the carriage return character.

Facsimile Command Syntax

After the "AT" or "at" prefix, facsimile commands use extended syntax. Each command is preceded by the "+F" character and consists of single characters and a decimal parameter (if applicable) terminated by the semicolon ":" character (ASCII 059) or by the <CR> that terminated the command line. A missing decimal parameter is evaluated as 0.

For example, the command to instruct the modem to automatically answer a data or fax call and also enable reception is:

```
AT+FAE=0; +FCR 1 <CR>
```

Basic data mode and fax service class mode select commands are:

```
AT+FCLASS=0 <CR>    for Data Mode
```

```
AT+FCLASS=1 <CR>    for Service Class 1 Fax
```

```
AT+FCLASS=2 <CR>    for Service Class 2 Fax
```

In Class 2, the DCE makes and terminates calls, manages the communication session and negotiates (T.30 protocol) and transports the image data to DTE. The T.4 protocol management of image data, etc., is done by DTE.

The response to

```
AT+FCLASS= 0<CR>    in Data Mode
```

or

```
AT+FCLASS=2<CR>    in Service Class 2 Fax
```

is

```
OK
```

The service class may be set by the DTE from the choices available using the "+FCLASS=<VALUE>" command.

General Rules

1. +Fnnn commands must be entered completely, otherwise an ERROR response is sent.
2. All response messages are preceded and followed by <CR><LF>. Multiple response commands (e.g., +FDIS: +FCSI: and +FDCS:) will, therefore, appear to have a blank line between them.

AT Commands for Central Site Modems Reference Manual

3. Fax Class 2 commands can be separated by the “.” character. The “;” character can be omitted if desired. Note that non-data commands cannot be separated by the “;” which is allowed as a dial modifier.

Table 6-1. Fax Class 2 Commands

Command	Function
Service Class ID	
+FCLASS=	Service Class
Class 2 Action Commands	
D	Originate a Call
A	Answer a Call
+FDT	Data Transmission
+FET=N	Transmit Page Punctuation
+FDR	Begin or Continue Phase C Receive Data
+FK	Session Termination
Class 2 DCE Responses	
+FCON	Facsimile Connection Response
+FDCS:	Report Current Session
+FDIS:	Report Remote Identification
+FCFR	Indicate Confirmation to Receive
+FTSI:	Report the Transmit Station ID
+FCSI:	Report the Called Station ID
+FPTS:	Page Transfer Status
+FET:	Post Page Message Response
+FHNG	Call Termination with Status
Class 2 Session Parameters	
+FMFR?	Identify Manufacturer
+FMDL?	Identify Model
+FREV?	Identify Revision
+FDCC=	DCE Capabilities Parameters
+FDIS=	Current Sessions Parameters
+FDCS=	Current Session Results
+FLID=	Local ID String
+FCR	Capability to Receive
+FPTS=	Page Transfer Status
+FCR=	Capability to Receive
+FAE	Adaptive Answer
+FBUF?	Buffer Size (Read Only)
+FPHCTO	Phase C Time Out
+FAXERR	Fax Error Value
+FBOR	Phase C Data Bit Order

AT Commands for Central Site Modems Reference Manual

4. All Class 2 commands are assumed to be the final command on a command line. Additional characters will be ignored.
5. An ERROR message will be generated if any of the following conditions occur:
 - a. A Class 1 command is received while in Class 2.
 - b. A Class 2 command is received while in Class 1.
 - c. A Class 1 or Class 2 action command is received while in data modem mode.
 - d. A Class 2 read-only parameter is given the "=" form of a +F command (e.g., AT+FAXERR=5).
 - e. A Class 2 action command is given the inappropriate "=" or "=?" form (e.g., AT+FDR=?).

6.1.2 Serial Port Speed and Flow Control

During fax mode, the DTE-DCE port speed is 19200 bps.

The DCE provides a speed buffer of 1024 bytes and provides the DC1/DC3 (XON/XOFF) or RTS/CTS method of controlling the data into the buffer. This flow control is controlled by the &K3 or &K4 command.

This method of data flow control is available only for DTE to DCE direction of data. There is no provision for data flow control from DCE to DTE.

Data Stream Termination

The DCE exchanges streams of data with the DTE while executing data transfer commands. These data streams use the termination described in Section 3.2/ISO 2111.

The ASCII <DLE> character (016) is used as a special character to shield special characters. The <DLE><ETX> character pair (<106><003>) is used to mark the end of a stream. The following patterns are used:

any data...<DLE><ETX>	end of stream
any data...<DLE><DLE>	single <DLE> in data
any data...<DLE><any byte>	delete <DLE><any byte>

DTE to DCE Streams

The DCE filters the data stream from the DTE, and removes all character pairs beginning with <DLE>. The DCE recognizes <DLE><ETX> as the stream terminator. The DCE recognizes <DLE><DLE> and reinserts a single <DLE> in its place.

The DTE must filter stream data to the DCE, and insert extra <DLE> characters ahead of data.

DCE to DTE Streams

The DTE must filter the data stream from the DCE, and remove all character pairs beginning with <DLE>. The DTE must recognize <DLE><ETX> as the stream terminator. The DTE must recognize <DLE><DLE> and reinsert a single <DLE> in its place.

The DCE filters stream data to the DTE, and inserts extra <DLE> characters ahead of data.

6.1.3 Auto Answer

The DCE can answer as a data DCE or as a fax DCE. It can answer the call adaptively, i.e., it can determine whether the call is 'data' or 'fax'. The +FAA parameter controls this feature. Fax adaptive answer operates only when +FCLASS=0.

AT+FAA=1	; Auto answer as a facsimile or a data modem depending on the call
CONNECT XXXX	; DCE status response if data call
+FCON	; DCE status response if fax call

6.1.4 Identification of T.30 Options

Group 3 devices negotiate session parameters in DIS, DCS, and DTC frames. These parameters are defined in Table 6-2.

AT Commands for Central Site Modems Reference Manual

6.1.5 Session Status Reporting

The DCE provides reports to the DTE on the status of a session. The DCE provides the following status reports:

1. Connection and hang up status:
+FCON
+FHNG:<0-255>
2. Requested DIS session parameters +FDIS: <string> reports remote facsimile capabilities.
Syntax: +FDIS: VR, BR, WD, LN, DF, EC, BF, ST
3. +FDCS: <string> reports the negotiated parameters
4. Phase C prompts:
XON, XOFF, DC2
5. Phase C base status reports: depending upon copy quality and related end-of page status:
+FPTS: <1-5>

6.1.6 Procedure Interrupt Negotiation

CCITT allows a station to request a procedure interruption at the end of a page. This request is passed between stations by the PIP, PIN, and PRI-Q messages.

6.2 SERVICE CLASS 2 IDENTIFICATION AND SELECTION

Three commands report identification and selection information. Each of these three commands cause the DCE to send a message to the DTE. The messages are programmable using ConfigurACE.

6.2.1 +FMFR?, Request Manufacturer Identification

The +FMFR? command causes the DCE to send a message identifying the DCE product manufacturer. The default message is:

```
ROCKWELL  
OK
```

6.2.2 +FMDL?, Identify Product Model

The +FMDL? command causes the DCE to send a message identifying the DCE product model. The default message is similar to:

```
RC96XXXAC  
OK
```

6.2.3 +FREV?, Identify Product Revision

The +FREV? command causes the DCE to send a message identifying the DCE product model revision number. The message format is the same as the ATI3 message, e.g.:

```
VX.XXX-model number  
OK
```

6.3 SERVICE CLASS 2 ACTION COMMANDS

These commands transfer data, and punctuate sessions. They also release specific T.30 messages. All action commands must be the last command on a command line as indicated by the terminating <CR>.

All action commands initiate processes. The modem will not accept other commands from the DTE until the modem issues a final result code (e.g., OK, CONNECT). The modem will abort the process if it receives any character before the final result code is issued.

AT Commands for Central Site Modems Reference Manual

6.3.1 ATD, Originate a Call

Syntax: ATD...<CR>

The DCE can support a DTE command to originate a call using the ATD command (see Section 3.2).

If this command is unsuccessful, the DCE reports an appropriate failure or error type result code such as NO CARRIER, NO DIALTONE, or BUSY (see Section 3.3).

If this call is successful, the typical DCE response is:

```
ATDnn..nn          (go off-hook, dial, get CED)
+FCON              (DCE detects flags)
[+FCSI:<remote ID string>]
+FDCS:<T.30 subparameter string>
OK
```

The DCE dials, detects call progress, and generates the CNG tone. It then waits for a DIS frame. On detection of the first Phase B preamble (V.21 ch. 2 modulated by 300 bps HDLC flags), it reports the "+FCON" message to the DTE. The DCE then switches to 19200 bps.

The DCE generates a DCS frame based on the received DIS frame and on the previously set +FDIS parameter. A +FDT command from the DTE releases the DCE to transmit that DCS frame.

The DCE reports the initial received T.30 negotiation messages, including the DIS frame and the optional CSI ID string. The +FDIS: report is followed by the OK final result code.

6.3.2 ATA, Answer a Call

The DCE can support a DTE command to answer an incoming call using the ATA command (see Section 3.2).

The DTE may issue an Answer command in response to an incoming ring.

If the Answer command is unsuccessful, the DCE will report an appropriate failure or error type result code, such as NO CARRIER (see Section 3.3).

Manual Call Answer

If this call is successful, the typical DCE response (answer and receive) is:

```
+FCON
[+FTSI:<remote ID string>]
+FDCS:<T.30 subparameter string>
OK
(DTE should issue +FDR command here)
```

Upon receipt of an Answer command from the DTE, the DCE answers and generates the CED tone. The DCE then generates a DIS frame (derived from the +FDIS parameter) and hunts for the first T.30 negotiation frames. Upon detection of the first Phase B preamble (V.21 ch 2 modulated by 300 bps HDLC flags), it reports the "+FCON" message to the DTE.

The DTE should report the initial received T.30 negotiation messages, including the DCS frame. The +FDCS: report will be followed by the OK final result code.

Automatic Answer

The modem provides for automatic answering of incoming calls. If configured for automatic answer, the modem answers an incoming call in compliance with T.30, and reports the same messages as described for manual answer.

Connection as a Data Modem

If configured to do so by the +FAA parameter, the DCE will adaptively answer as a facsimile DCE or as a data DCE. If the DCE answers as a data DCE, it resets the +FCLASS parameter to 0 and issues the appropriate final result code (e.g., CONNECT, or NO CARRIER) to the DTE.

AT Commands for Central Site Modems Reference Manual

6.3.3 +FDT, Data Transmission

Syntax: +FDT <CR>

The +FDT command prefixes Phase C data transmission. When the DCE is ready to accept Phase C data, it issues the negotiation responses and the CONNECT result code to the DTE.

In Phase B, the +FDT command releases the DCE to proceed with negotiation, and releases the DCS message to the remote station. In Phase C, the +FDT command resumes transmission after the end of a prior transmit data stream.

Initiate Page Transmission

Phase B DCE polled response:

[+FCSI:<remote ID string>]	- if new CSI received
[+FDIS:<subparameters from remote station>]	- if new DIS received
+FDCS:<T.30 subparameter string>	
CONNECT	
<XON>	- when ready for data

After placing a call, or after finishing a document exchange, the DTE may command the DCE to re-enter T.30 Phase B to attempt to negotiate a document transmission.

Continue a Page

CONNECT
<XON>

The DTE may issue more than one +FDT command for a given page, so that different files may be concatenated together. These files must have the same format.

Phase C Data Framing

Phase C data must be presented to the DCE in stream mode. The DCE expects Phase C data to follow until it detects <DLE><ETX> termination characters. The DCE will filter the stream as described in Section 6.1.2.

The DCE will acknowledge the end of the data by returning the OK result code to the DTE.

If there is data underrun before the next +FDT or +FET= command, the DCE will zero-fill the pad as per T.4 until the Phase C timeout (+FPHCTO) is reached, or until more data is received. The DCE appends an RTC pattern to the transmit data after an +FET= command is received from the DTE.

Phase C Data Format

The Phase C data will be of the format specified by the negotiated T.30 DCS frame. The +FDCS:<string> response is defined in Section 6.4.2. The subparameter values are described in Table 6-2.

The DCE will use the negotiated minimum Scan Time parameter from the DCS frame, and insert sufficient fill bits to pad each line to the minimum scan time. This is reported in the +FDCS:ST subparameter.

If the DCE finds more than one consecutive EOL in Phase C data (e.g., RTC), it will send only one EOL.

1. Phase C data must conform to T.4 specifications.
2. The DTE need not include a final RTC, since the DCE will append an RTC in response to an FET= command.
3. Some facsimile machines may treat two EOLs as an RTC.

<CAN>, Escape from Transmission

The DCE may request the DTE to halt Phase C transmission, by sending a cancel <CAN> character (024) to the DTE. In this case, the DTE should terminate Phase C transmission, issue <CAN>, and wait for the OK response code from the DCE.

AT Commands for Central Site Modems Reference Manual

Table 6-2. T.30 Session Subparameter Codes

Label	Function	Value	Description
VR	Vertical Resolution	0	Normal, 98 lpi
		1	Fine, 196 lpi
BR	Bit Rate (See Note 1)	0	+FDCS (originate) +FDIS (answer) 2400 bps/V.27 ter V.27 ter (2400 only)
		1	4800 bps/V.27 ter V.27 ter
		2	7200 bps/V.29 V.29, V.27 ter
		3	9600 bps /V.29 or V.17 V.29, V.27 ter
		4	12000 bps/V.33 or V.17 V.17, V.33, V.29, V.27 ter
		5	14400 bps/V.33 or V.17 V.17, V.33, V.29, V.27 ter
WD	Page Width	0	1728 pixels in 215 mm
		1	2048 pixels in 255 mm
		2	2432 pixels in 303 mm
		3*	1216 pixels in 151 mm
		4*	864 pixels in 107 mm
LN	Page Length	0	A4, 297 mm
		1	B4, 364 mm
		2	unlimited length
DF	Data Compression Format	0	1-D modified Huffman
		1*	2-D modified Read
		2*	2-D uncompressed mode
		3*	2-D modified modified Read
EC	Error Correction (Annex A/T.30)	0	Disable ECM
		1*	Enable ECM, 64 bytes/frame
		2*	Enable ECM, 256 bytes/frame
BF	Binary File Transfer	0	Disable BFT
		1*	Enable BFT
ST	Scan Time/Line		VR = normal VR = fine
		0	0 ms 0 ms
		1	5 ms 5 ms
		2	10 ms 5 ms
		3	10 ms 10 ms
		4	20 ms 10 ms
		5	20 ms 20 ms
		6	40 ms 20 ms
7	40 ms 40 ms		

Notes: 1. CCITT T.30 does not provide for the answering station to specify all speeds exactly using the DIS frame. Implementation of some BR codes (e.g., code 2) by an answering DCE is manufacturer specific.

* Not supported.

AT Commands for Central Site Modems Reference Manual

6.3.4 +FET, Transmit Page Punctuation

Syntax: +FET=<ppm>[,<pc>,<bc>,<fc>]

DCE response:

+FPTS:<ppr> - when receive from remote OK

This command is used to punctuate page and document transmission after one or more +FDT commands. This command generates T.30 Post Page Messages selected by the <ppm> code (Table 6-3).

The +FET=<ppm> command indicates that the current page is complete; no more data will be appended to it. The value indicates whether there are any additional pages are to be sent and, if so, whether there is a change in any of the document parameters.

The DTE can command the DCE to generate PRI-Q messages with the +FET=<ppm> command using ppm codes 4-6 (Table 6-3).

This command must be sent within the time out specified by +FPHCTO after sending Phase C data, or else the DCE will end the page and document transmission. If the Phase C timeout is reached, the DCE sends an EOP post page message and terminates the session.

The remote facsimile station should respond to the post page message with a post page response. The DCE will report this using the +FPTS:<ppr> response (Table 6-4).

End a Page

The +FET= command causes the DCE to append an RTC (6 EOL) pattern as needed and enter Phase D by sending the selected T.30 Post Page message.

The +FET=1 (EOM) command signals the remote station that the next document will have a new DCS negotiated; this causes the session to re-enter Phase B.

Table 6-3. T.30 Post Page Message Codes

ppm Code	Mnemonic	Description
0	[PPS-]MPS	Another page next, same document
1	[PPS-]EOM	Another document next
2	[PPS-]EOP	No more pages or documents
3	PPS-NULL	Another partial page next
4	[PPS-]PRI-MPS	Another page, procedure interrupt
5	[PPS-]PRI-EOM	Another doc., procedure interrupt
6	[PPS-]PRI-EOP	All done, procedure interrupt
=8+ppm		Post Page Message (ppm code)

Table 6-4. T.30 Post Page Response Messages

ppr Code	Mnemonic	Description
1	MCF	Page good
2	RTN	Page bad; retrain requested
3	RTP	Page good; retrain requested
4	PIN	Page bad; interrupt requested
5	PIP	Page good; interrupt requested

AT Commands for Central Site Modems Reference Manual

6.3.5 +FDR, Begin or Continue Phase C Receive Data

Syntax: +FDR <CR>

Default value: 3 seconds in some places

The +FDR command initiates transition to Phase C data reception. This can occur after answering, dialing, a document is received, or a page is received.

The DCE reports the negotiated T.30 parameters, with the remote ID information if available. When the DCE is ready to commence data transfer, it issues a CONNECT response code. If the DCE cannot resume data transfer because there is no more data, it responds OK. When the DTE is ready to accept data, it issues an <DC2> character (018) to the DCE.

If the DTE issues an <XOFF> character to the DCE for flow control, the DCE signals the DTE when its buffers are empty by sending a <DLE><DC2> (<016><018>) character pair.

When the DCE delivers the last byte of a page, the DCE reports the Page Transfer Status via the +FPTS:<ppr> response (Table 6-4).

After a Page Transfer Status Report, the DCE reports the post page message from the remote facsimile station via the +FET:<ppm> response (Table 6-3) which signals the intentions of the remote station.

The DCE holds the post page response message to the remote facsimile station (MCF, etc.), represented in the +FPTS parameter until the next +FDR command. The DTE may modify the +FPTS parameter before issuing the +FDR command which releases that message. The DTE must issue a +FDR command to release Post Page Messages.

Initiate Document Reception

The +FDR command may be issued in Phase B after an answer command, or in Phase B after a previous document.

The DCE response in stream mode is:

+FCFR	when CFR sent
[+FTSI:<remote ID string>]	if new TSI received
+FDCS:<T.30 subparameter string>]	if new DCS
CONNECT	
(<DC2> needed from DTE here)	
<Phase C data stream>	
<DLE><ETX>	
+FPTS:<ppr>, <lc> [,<blc>, <cbic>]	
+FET:<ppm>	
OK	
(DTE must issue +FDR command to release post page response)	

AT Commands for Central Site Modems Reference Manual

Continue Document Reception

The DTE may issue a +FDR command in Phase D, which releases the post page message, and indicates readiness to receive another page after receipt of a Multipage (+FET:0) or PPS-NULL (+FET:3) message. The DCE response will be:

```
CONNECT
(<DC2> needed from DTE here)

<Phase C data stream>
<DLE><ETX>
+FPTS:<ppr>, <lc> [,<b1c>, <cbc>]
+FET:<ppm>
OK
(DTE must issue +FDR command to release post page response)

If done receiving:

+FHNG: <hangup cause code>
OK
```

Continue page reception

Phase C Data Framing

Phase C data may be presented to the DTE in stream mode. The DCE will transfer a stream of data to the DTE, followed by the <DLE><ETX> stream termination characters. The DCE will filter the stream as described in Section 6.1.2.

Phase C Data Format

The received data format is negotiated under T.30 reported by the +FDCS:VR,BR,WD,LN,DF,EC,BF,ST response.

The DCE will delete the terminating RTC (6 EOLs) patterns.

<CAN>, Escape from Reception

From the +FDR command until the end of Phase D Date, the DCE is in a data transfer state, and will not respond to DTE command characters. The DCE will respond to three ASCII control characters: <DC1> (017) and <DC3> (019) flow control characters, and cancel <CAN> (024).

Upon receipt of the <CAN> character, the DCE will terminate the reporting of received data by sending trailing <DLE><ETX> characters to the DTE, and will then execute an implied +FK command in order to conduct an orderly disconnection.

6.3.6 +FK, Session Termination

Syntax: +FK

The +FK command causes the DCE to terminate the session in an orderly manner. In particular, the DCE will send a DCN message at the next opportunity and hang up. At the end of the termination process, the DCE will report the +FHNG response with result code (Table 6-5).

This operation can be invoked by using the cancel <CAN> character during Phase C data reception (see prior section)

The DCE will wait until the current page completes, unless the reception is of unlimited length; in that case, the DCE may halt reception and terminate the session at any time.

AT Commands for Central Site Modems Reference Manual

6.3.7 +FCIG, Set Polling ID

This command allows setting the Local Polling ID string used in a CIG frame. The syntax of this command is identical to +FLID.

Write syntax: +FCIG="<local ID string>"

Valid value: 20-character ASCII string

Default value: Empty

6.3.8 +FLPL, Indicate a Document for Polling

This command allows setting up an answering modem to know that it has a document available for polling. This allows a calling modem to receive this fax from the answerer. The syntax is:

```
AT+FLPL=?  
0,1
```

```
OK  
AT+FLPL=1
```

```
OK  
AT+FLPL?  
1
```

6.3.9 +FSPL, Enable Polling

This command allows setting up an originating modem to be able to request to receive a document from a polled station. The syntax is:

```
AT+FSPL=?  
0,1
```

```
OK  
AT+FSPL=1
```

```
OK  
AT+FSPL?  
1
```

AT Commands for Central Site Modems Reference Manual

Table 6-5. Hang Up Status Codes

Code	Cause Description
0-9	Call Placement and Termination
0	Normal and proper end of connection
1	Ring Detect without successful handshake
2	Call aborted, from +FK or AN
3	No Loop Current
10-19	Transmit Phase A & Miscellaneous Errors
10	Unspecified Phase A error
11	No Answer (T.30 T1 timeout)
20-39	Transmit Phase B Hangup Codes
20	Unspecified Transmit Phase B error
21	Remote cannot receive or send
22	COMREC error in transmit Phase B
23	COMREC invalid command received
24	RSPEC error
25	DCS sent three times without response
26	DIS/DTC received 3 times; DCS not recognized
27	Failure to train at 2400 bps or +FMINSR value
28	RSPREC invalid response received
40-49	Transmit Phase C Hangup Codes
40	Unspecified Transmit Phase C error
43	DTE to DCE data underflow
50-69	Transmit Phase D Hangup Codes
50	Unspecified Transmit Phase D error
51	RSPREC error
52	No response to MPS repeated 3 times
53	Invalid response to MPS
54	No response to EOP repeated 3 times
55	Invalid response to EOP
56	No response to EOM repeated 3 times
57	Invalid response to EOM
58	Unable to continue after PIN or PIP
70-89	Receive Phase B Hangup Codes
70	Unspecified Receive Phase B error
71	RSPREC error
72	COMREC error
73	T.30 T2 timeout, expected page not received
74	T.30 T1 timeout after EOM received
90-99	Receive Phase C Hangup Codes
90	Unspecified Receive Phase C error
91	Missing EOL after 5 seconds
92	Unused code
93	DCE to DTE buffer overflow
94	Bad CRC or frame (ECM or BFT modes)
100-119	Receive Phase D Hangup Codes
100	Unspecified Receive Phase D errors
101	RSPREC invalid response received
102	COMREC invalid response received
103	Unable to continue after PIN or PIP
120-255	Reserved Codes
Note: Some codes are not implemented.	

AT Commands for Central Site Modems Reference Manual

6.4 SERVICE CLASS 2 DCE RESPONSES

The DCE sends information responses to the DTE as a facsimile session proceeds. They indicate the state of the facsimile session and convey needed information. These messages are solicited messages generated in execution of DTE action commands described in Section 6.3.

The DCE precedes and follows the information responses with <CR><LF>.

The DCE provides the on-line status of several session parameters when they are available during T.30 handshaking. These include the remote ID string and the DIS/DCS parameters. These responses report the T.30 session parameter frames. The subparameters are described in Table 6-2.

6.4.1 +FCON, Facsimile Connection Response

+FCON indicates connection with a fax machine. It is released by detection of HDLC flags in the first received frame. +FCON is generated in response to an Originate or Answer command.

6.4.2 +FDCS:, Report Current Session Capabilities

Syntax: +FDCS:VR,BR,WD,LN,DF,EC,BF,ST

+FDCS:<string> reports the negotiated parameters. Phase C data will be formatted as described by the subparameters. This message may be generated in execution of +FDT or +FDR commands before the CONNECT result code if new DCS frames are generated or received. (See Table 6-2.)

6.4.3 +FDIS:, Report Remote Station Capabilities

Syntax: +FDIS:VR,BR,WD,LN,DF,EC,BF,ST

+FDIS:<string> reports remote facsimile station capabilities and intentions. The parameters are provided in ASCII notation. (See Table 6-2.)

This message is generated in execution of Originate, Answer, +FDT, or +FDR commands.

6.4.4 +FCFR, Indicate Confirmation to Receive

Syntax: +FCFR

The DCE sends a +FCFR response to the DTE upon reception of an acceptable TCF training burst and a valid DCS signal from the remote machine. This indicates that the DCE will receive Phase C data after the remote station receives the local DCE's CFR message. The +FCFR message is generated in execution of a +FDR command.

6.4.5 +FTSI:, Report the Transmit Station ID

Syntax: +FTSI: "<TSI ID string>" Transmit Station ID

This response reports the received transmit station ID string, if any. This message is generated in execution of Originate, Answer, +FDT, or +FDR commands.

6.4.6 +FCSI:, Report the Called Station ID

Syntax: +FCSI: "<CSI ID string>" Called Station ID

This response reports the received called station ID string, if any. This message is generated in execution of Originate, Answer, +FDT, or +FDR commands.

AT Commands for Central Site Modems Reference Manual

6.4.7 +FPTS:, Receive Page Transfer Status

Syntax: +FPTS:<ppr>, <lc> [,<blc>, <cblc>]

The +FPTS:<ppr> is generated by the DCE at the end of Phase C data reception in execution of a +FDR command.

The <ppr> is generated by the DCE; it depends on the DCE capabilities at T.4 error checking. See Table 6-4 for <ppr> values.

The receiving DCE will count the lines. These values are;

<lc> = line count

<blc> = bad line count

<cblc> = <consecutive bad line count

A receiving DTE may inspect <ppr> and write a modified value into the +FPTS parameter. The DCE will hold the corresponding Post Page Response message until released by a +FDR command from the DTE.

6.4.8 +FET:, Post Page Message Response

Syntax: +FET:<ppm>

The +FET:<post page message> response is generated by a receiving DCE after the end of Phase C reception on receipt of the post-page message from the transmitting station. The +FET:<ppm> response is generated in execution of a +FDR command. The <ppm> codes respond to the T.30 post page messages (Table 6-3).

6.4.9 +FPTS:, Transmit Page Transfer Status

Syntax: +FPTS:<ppr>

The +FPTS: response reports a <ppr> number representing the copy quality and related post-page message responses received from the remote DCE. The valid <ppr> values are defined in Table 6-4.

The +FPTS:<ppr> response is generated in execution of a +FET=<ppm> command.

6.4.10 +FHNG:, Call Termination with Status

Syntax: +FHNG:<hangup status code>

+FHNG indicates that the call has been terminated. The hangup cause is reported and stored in the +FAXERR parameter for later inspection. The <hangup status code> values are described in Table 6-5.

+FHNG:<hsc> is a possible intermediate result code to any DTE action command described in Section 6.3. It is always followed by the OK final result code.

Upon termination of a call, the DCE determines the cause of termination and reports it as part of the FHNG:<hsc> response. It also stores this <hsc> code in the +FAXERR parameter for later inspection.

The hangup values are organized according to the phases of the facsimile transaction as defined by T.30. In the Figure A/T.30 flow charts, there are decision boxes labelled "Command Received?"; this is referred to as COMREC in the table. Similarly, decision boxes labelled "Response Received?" are referred to as RSPREC in the table. A COMREC error or RSPREC error indicates that one of two events occurred: 1) a DCN (disconnect) signal was received, or 2) an FCS error was detected and the incoming signal was still present after 3 seconds. (See Figure A/T.30).

The table values are in decimal notation. Leading zero characters are optional.

AT Commands for Central Site Modems Reference Manual

6.4.11 +FCIG:, Report the Polled Station ID

Syntax: +FCIG: "< ID string>" Polled Station ID

This response reports the received transmit station ID string, if any. This message is generated in execution of Originate, Answer, +FDT, or +FDR commands.

6.4.12 +FDTC:, Report the Polled Station Capabilities

Syntax: +FDTC: "< string>" Polled Station Capabilities

If the answerer has a document to poll, it would be communicated to the originator in bit 9 of the DIS frame. The originating station may elect to transmit a fax, and later, send SIG and DTC frames to pick up the polled document. The answering station would report the incoming DTC frame via the +FDTC: response message after command mode is cancelled with the AT+FDR command.

6.4.13 +FPOLL, Indicate Polling Request

Syntax: +FPOLL:

This message is sent to the DTE if the received DIS message indicates that the remote station has a document to poll (by bit 9 in the DIS) and polling has been enabled with the AT+FSPL command. The DTE may then decide to receive rather than transmit.

AT Commands for Central Site Modems Reference Manual

6.5 SERVICE CLASS 2 PARAMETERS

All Service Class 2 parameters can be read, written, and tested for range of legal values by the DCE. The general syntax is described in Section 6.1.

Group 3 FAX devices negotiate session parameters in DIS, DCS, and DTC frames. The following parameters are provided to condition the facsimile DCE for the capabilities it will offer and to report the session settings negotiated.

The three primary T.30 session parameters are +FDCC, +FDIS and +FDCS. They are compound parameters, using values

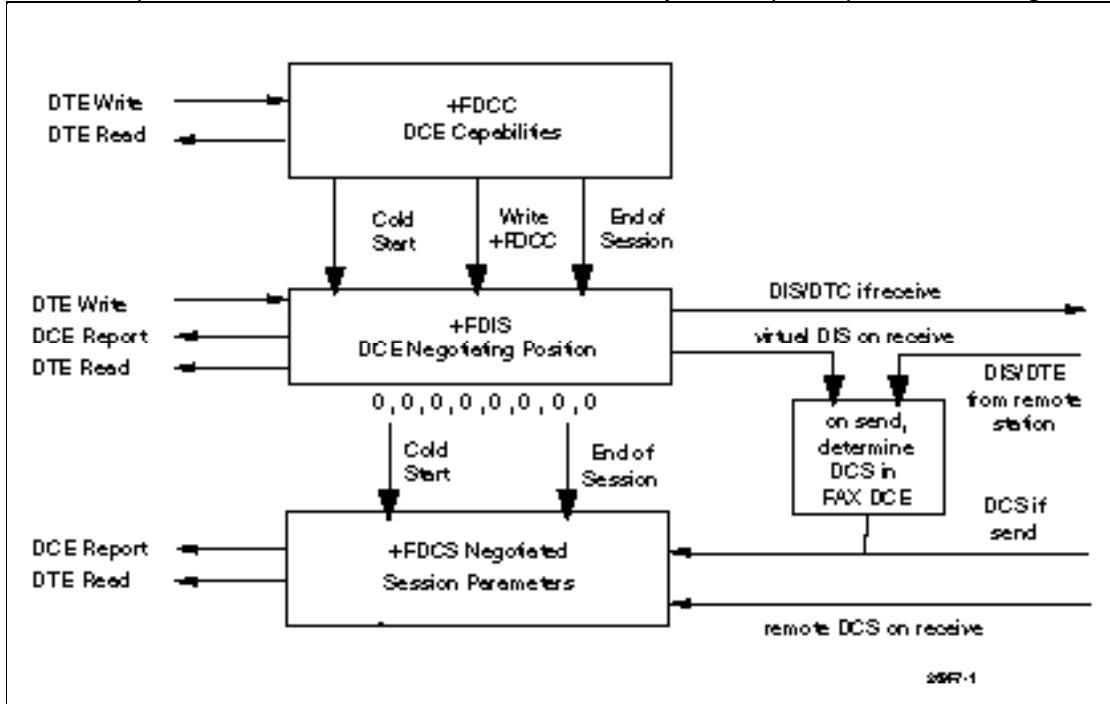

listed in Table 6-2 .

Figure 6-1 illustrates their relationships.

AT Commands for Central Site Modems Reference Manual

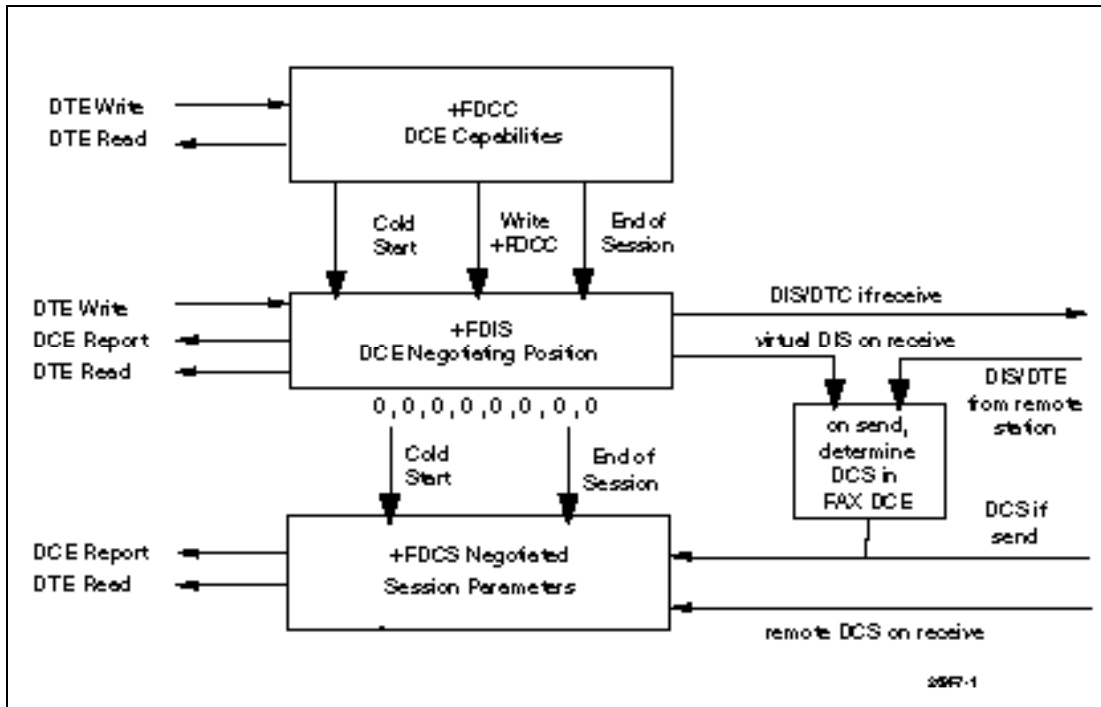

Figure 6-1. T.30 Session Parameter Relationships

6.5.1 +FDCC, DCE Capabilities Parameters

Write syntax: +FDCC=VR,BR,WD,LN,DF,ED,BF,ST

Valid values: See Table 6-2

Default values: 0,3,0,2,0,0,0,0 (9600 bps fax models) or 0,5,0,2,0,0,0,0 (14400 bps fax models)

+FDCC allows the DTE to sense and constrain the capabilities of the facsimile DCE from the choices defined in CCITT T.30 Table 2. When +FDCC is modified by the DTE, the DCE copies +FDCC into +FDIS.

6.5.2 +FDIS, Current Sessions Capabilities Parameters

Write syntax: +FDIS=VR,BR,WD,LN,DF,EC,BF,ST

Valid values: See Table 6-2

Default values: 0,3,0,2,0,0,0,0 (9600 bps fax models) or 0,5,0,2,0,0,0,0 (14400 bps fax models)

The +FDIS parameter allows the DTE to sense and constrain the capabilities used for the current session. The DCE uses +FDIS to generate DIS or DTC messages directly, and uses +FDIS and received DIS messages to generate DCS messages.

The DCE initializes the +FDIS parameter from the +FDCC parameter on initialization, when +FDCC is written, and at the end of a session.

AT Commands for Central Site Modems Reference Manual

6.5.3 +FDCS, Current Session Results Parameters

Read syntax: +FDCS?

DCE response: +FDCS=VR,BR,WD,LN,DF,EC,BF,ST

or +FDCS=

Valid values: See Table 6-2

Default values: 0,0,0,0,0,0,0

The +FDCS parameter is loaded with the negotiated T.30 parameters for the current session. A transmitting DCE generates DCS; a receiving DCE gets DCS from the remote station. The DTE may read this parameter.

The +FDCS parameter is initialized 0,0,0,0,0,0,0 upon initialization and at the beginning of a session. If the DTE issues a +FDCS? command in the initial state, the DCE reports:

```
<CR><LF>0,0,0,0,0,0,0<CR><LF>
```

The contents of +FDCS are spontaneously reported during execution of +FDR or +FDT commands by the +FDCS:VR,BR,WD,LN,BF,EC,BF,ST response using the same compound parameter format.

Several commands and responses reference T.30 session negotiated parameters. These are described by a set of common subparameters. These subparameters are described in Table 6-2 with notes. Optional parameter values are marked with an *. Unspecified parameter values are reserved for future use.

The +FDCC, +FDIS, and +FDCS compound parameters use these session parameters (On writes, unspecified subparameters are unchanged.)

The +FDIS:, +FDCS:, and +FDTC: session report responses use these subparameters.

For test response, ranges of values are reported for each subparameter enclosed in parentheses characters. For example, a DCE response to +FDCC=? could report:

```
<CRLF> (0,1), (0-5), (0-3), (0-2), (0-2), (0-2), (0), (0-7) <CRLF> (14400 fax models)
```

Example:

```
+FDIS=0,5,0,2,0,0,0,1 =
```

VR = 0	98 dpi vertical resolution,
BR = 5	14400 bit/s
WD = 0	1728 pixels,
LN = 2	unlimited length
DF = 0	1-D modified Huffman coding,
EC = 0	no ECM,
BF = 0	no BFT,
ST = 1	5 ms scan time.

AT Commands for Central Site Modems Reference Manual

6.5.4 +FLID=, Local ID String

Write syntax: +FLID="<local ID string>"

Valid value: 20-character ASCII string

Default value: Empty

If FLID is not a null string, it generates a TSI or CSI frame. Table 3/T.30 includes digits 0-9, "+" and space.

If the DCE supports use of Table 3/T.30 only, the response to a +FLID=? command is "(20) (32, 43, 48-57)." If the DCE supports printable ASCII <, the response is: "(20) (32-127)<CRLF>." The first "(20)" represents string length: the second (character values) field reports supported string values.

1. The string is saved in RAM.
2. Non-numeric characters are not filtered out.
3. The string is right justified.

6.5.5 +FCR, Capability to Receive

Write syntax: +FCR=<value>

Valid values: 0 or 1

Default value: 0

+FCR=0 indicates that the DCE will not receive message data. This can be used when the DTE has insufficient storage. The DCE can send and can be polled for a file.

+FCR is sampled in CCITT T.30 Phase A and Phase D.

6.5.6 +FPTS=, Page Transfer Status

Write Syntax: +FPTS=<ppr>

Valid values: 1, 2, 3, 4, 5

Default value: 0

The +FPTS parameter contains a value representing the post page response, including copy quality and related end-of-page status. These values correspond to post page response messages defined in T.30. The receiving DCE sets this parameter after it receives a page of Phase C data. The transmitting DCE sets this parameter with the status reported by the receiving station. The DTE may inspect or modify this parameter.

The set of <ppr> values is defined in Table 6-4. These values are also reported in the +FPTS response to the +FDR command.

6.5.7 +FCQ, Copy Quality Checking

Write syntax: +FCQ=<value>

Valid values: 0

Default value: 0

This parameter controls Copy Quality checking by a receiving facsimile DCE.

The DCE returns +FCQ=0 which indicates the DCE does no quality checking. The DCE will generate Copy Quality OK (MCF) responses to complete pages, and set +FPTS=1.

6.5.8 +FPHCTO, DTE Phase C Response Time-out

Write syntax: +FPHCTO=<value>

Valid values: 0 - 255, 100 millisecond units.

Default value: 30

AT Commands for Central Site Modems Reference Manual

The +FPHCTO command determines how long the DCE will wait for a command after reaching the end of data when transmitting in Phase C. When this time-out is reached, the DCE assumes there are no more pages and no documents to send. It then sends the T.30 EOP response to the remote device.

6.5.9 +FAXERR, T.30 Session Error Report

Read syntax: +FAXERR= <table value>, read only

Valid values: 0 - 255, see Table 6-5 for meaning

This read-only parameter indicates the cause of the hangup. Table 6-5 shows the valid values for this parameter as well as the meaning of the each value. +FAXERR is set by the DCE at the conclusion of a fax session. The DCE resets +FAXERR to 0 at the beginning of Phase A off-hook time.

6.5.10 +FBOR, Data Bit Order

Write syntax: +FBOR=<value>

Valid values: 0, 1, 2, or 3

Default value: 0

This parameter controls the mapping between PSTN facsimile data and the DTE-DCE link. There are two choices:

Direct: The first bit transferred to each byte on the DTE-DCE link is the first bit transferred on the PSTN data carrier.

Reversed: The last bit transferred of each byte on the DTE-DCE link is the first bit transferred on the PSTN data carrier.

There are two data types to control:

This command controls Phase C data (T.4 encoded data) transferred during execution of +FDT or +FDR commands.

The following two codes are supported:

+FBOR=0 or 2 Selects direct bit order for Phase C data.

+FBOR=1 or 3 Selects reversed bit order for Phase C data.

Note that this parameter does not affect the bit order of control characters generated by the DCE.

6.5.11 +FAA, Answer Parameter

Write syntax: +FAA=<value>

Valid values: 0 or 1

Default value: 0

+FAA=0 Constrains the DCE to answer as set by +FCLASS.

+FAA=1 Indicates that the DCE can answer and automatically determine whether to answer as a Class 2 facsimile DCE or as a data modem. If the DCE automatically switches, it modifies FCLASS appropriately.

Fax adaptive answer operates only when +FCLASS=0.

Class 2 adaptive answer is implemented as follows:

First, a data mode handshake is attempted. If the DCE has been configured for automode detection (using the +MS command), the DCE may try several protocols before terminating attempts to make a data mode connection. This can take as long as 6-8 seconds.

If the data mode connection attempt fails, a facsimile Class 2 connection is assumed. When a connection is made as a result of the adaptive answer, the DCE issues the DATA or FAX result code before the CONNECT or +FCON message to inform the DTE of the connection type. After making a Class 2 connection, the DCE stays on-line rather than going into the command mode as with a Class 1 connection.

AT Commands for Central Site Modems Reference Manual

6.5.12 +FBUF?, Buffer Size

Read syntax: +FBUF?

DCE response syntax: <bs>, <xoft>, <xont>, <bc>

where:

<bs> = total buffer size

<xoft> = XOFF threshold

<xcont> = XON threshold

<bc> = current buffer byte count

Example:

+FBUF?

512, 506, 500, 0

The +FBUF parameter allows the DTE to determine the characteristics of the DCE's data buffer. Data buffers are used for flow control. Use of the reported values allow the DTE to transfer data without provoking XOFF.

6.6 EXAMPLE SESSIONS

Tables 6-6 and 6-7 show the typical command and responses for sending and receiving two pages, respectively.

AT Commands for Central Site Modems Reference Manual

Table 6-6. Send Two Pages, 1-D, No Errors

DTE Command	DCE Response	Local DTE Action	Remote Station Action
AT+CLASS=2	OK	Set Class 2	x
AT+FLID="<local ID>"	OK	Set local ID	
AT<dial string>	+FCON [+FCSI:"<csi>"] +FDIS: <dis codes> OK	Off hook, dial Send CNG Detect flags [Get CSI] Get DIS	Answer, Send [CED] V.21 flags [CSI] DIS
AT+FDT <1st page data> <DLE><ETX>	+FDCS:<DCS codes> CONNECT <XON> OK	[Send TSI] Send DCS Send TCF Get CFR Send carrier Send page data	[Get TSI] Get DCS Get TCF Send CFR Receive carrier Receive page data
AT+FET=0	+FPTS:1 OK	Send RTC Get MPS Get MCF	Get RTC Get MPS Send MCF
AT+FDT <2nd page data> <DLE><ETX>	CONNECT <XON> OK	Send carrier Send page data	Receive carrier Receive page data
AT+FET=2	+FPTS:1 +FHNG:0 OK	Send RTC Send EOP Get MCF Send DCN Hang up	Get RTC Get EOP Send MCF Get DCN Hang up

AT Commands for Central Site Modems Reference Manual

Table 6-7. Receive Two Pages, 1-D Data, No Errors

DTE Command	DCE Response	Local DTE Action	Remote Station Action
AT+FCR=1	OK	Enable reception	
AT+FLID="<local ID>"	OK	Set local ID	
	RING	Detect ring	Dials[, Send CNG]
ATA	+FCON [+FTSI:"<tsi>"] +FDCS:<dcs codes> OK	Off hook Send CED Send CSI Send DIS Detect flags [Get TSI] Get DCS Begin TCF receive	Get CED Get CSI Get DIS Send V.21 flags [Send TSI] Send DCS Start TCF
AT+FDR <DC2>	+FCFR [+FDCS:"<dcs codes>"] CONNECT <page data stream> <DLE><ETX> +FPTS:1, <lc> +FET:0 OK	Accept TCF Send CFR Get page carrier Get page data Detect RTC Get MPS	Finish TCF Get CFR Send pager carrier Send page data Send RTC Drop carrier Send MPS
AT+FDR <DC2>	CONNECT <page data stream> <DLE><ETX> +FPTS:1, <lc> +FET:2 OK	Send MCF Get page carrier Get page data Detect RTC Get EOP	Get MCF Send page carrier Send page data Send RTC Drop carrier Send EOP
AT+FDR	+FHNG:0 OK	Send MCF Get DCN	Get MCF Send DCN

7. AT COMMAND SET SUMMARY

7.1 BASIC AT COMMANDS

Command	Function
A/	Re-execute command.
A	Go off-hook and attempt to answer a call.
B0	Select V.22 connection at 1200 bps.
B1	Select Bell 212A connection at 1200 bps.
C1	Return OK message.
Dn	Dial modifier.
E0	Turn off command echo.
E1	Turn on command echo.
H0	Initiate a hang-up sequence.
H1	If on-hook, go off-hook and enter command mode.
I0	Report product code.
I1	Report pre-computed checksum.
I2	Report OK.
I3	Report firmware revision, model, and interface type.
I4	Report response programmed by an OEM.
I5	Report the country code parameter.
I6	Report modem data pump model and code revision.
I7	Reports the DAA code (W-class models only).
L0	Set low speaker volume.
L1	Set low speaker volume.
L2	Set medium speaker volume.
L3	Set high speaker volume.
M0	Turn speaker off.
M1	Turn speaker on during handshaking and turn speaker off while receiving carrier.
M2	Turn speaker on during handshaking and while receiving carrier.
M3	Turn speaker off during dialing and receiving carrier and turn speaker on during answering.
N0	Turn off automode detection.
N1	Turn on automode detection.
O0	Go on-line.
O1	Go on-line and initiate a retrain sequence.
P	Force pulse dialing.
Q0	Allow result codes to DTE.
Q1	Inhibit result codes to DTE.
Sn	Select S-Register as default.
Sn?	Return the value of S-Register n.
=v	Set default S-Register to value v.
?	Return the value of default S-Register.
T	Force DTMF dialing.

AT Commands for Central Site Modems Reference Manual

V0	Report short form (terse) result codes.
V1	Report long form (verbose) result codes.
W0	Report DTE speed in EC mode.
W1	Report line speed, EC protocol and DTE speed.
W2	Report DCE speed in EC mode.
X0	Report basic call progress result codes, i.e., OK, CONNECT, RING, NO CARRIER (also, for busy, if enabled, and dial tone not detected), NO ANSWER and ERROR.
X1	Report basic call progress result codes and connections speeds (OK, CONNECT, RING, NO CARRIER (also, for busy, if enabled, and dial tone not detected), NO ANSWER, CONNECT XXXX, and ERROR.
X2	Report basic call progress result codes and connections speeds, i.e., OK, CONNECT, RING, NO CARRIER (also, for busy, if enabled, and dial tone not detected), NO ANSWER, CONNECT XXXX, and ERROR.
X3	Report basic call progress result codes and connection rate, i.e., OK, CONNECT, RING, NO CARRIER, NO ANSWER, CONNECT XXXX, BUSY, and ERROR.
X4	Report all call progress result codes and connection rate, i.e., OK, CONNECT, RING, NO CARRIER, NO ANSWER, CONNECT XXXX, BUSY, NO DIAL TONE and ERROR.
Y0	Disable long space disconnect before on-hook.
Y1	Enable long space disconnect before on-hook.
Z0	Restore stored profile 0 after warm reset.
Z1	Restore stored profile 1 after warm reset.
&C0	Force RLSD active regardless of the carrier state.
&C1	Allow RLSD to follow the carrier state.
&D0	Interpret DTR ON-to-OFF transition per &Qn: &Q0, &Q5, &Q6 The modem ignores DTR. &Q1, &Q4 The modem hangs up. &Q2, &Q3 The modem hangs up.
&D1	Interpret DTR ON-to-OFF transition per &Qn: &Q0, &Q1, &Q4, &Q5, &Q6 Asynchronous escape. &Q2, &Q3 The modem hangs up.
&D2	Interpret DTR ON-to-OFF transition per &Qn: &Q0 through &Q6 The modem hangs up.
&D3	Interpret DTR ON-to-OFF transition per &Qn: &Q0, &Q1, &Q4, &Q5, &Q6 The modem performs soft reset. &Q2, &Q3 The modem hangs up.
&F0	Restore factory configuration 0.
&F1	Restore factory configuration 1.
&G0	Disable guard tone.
&G1	Disable guard tone.
&G2	Enable 1800 Hz guard tone.
&J0	Set S-Register response only for compatibility.
&J1	Set S-Register response only for compatibility.
&K0	Disable DTE/DCE flow control.
&K3	Enable RTS/CTS DTE/DCE flow control.
&K4	Enable XON/XOFF DTE/DCE flow control.
&K5	Enable transparent XON/XOFF flow control.
&K6	Enable both RTS/CTS and XON/XOFF flow control.
&L0	Select dial up line operation.

* Serial interface operation only.

AT Commands for Central Site Modems Reference Manual

&M0	Select direct asynchronous mode.
&M1	Select sync connect with async off-line command mode. *
&M2	Select sync connect with async off-line command mode and enable DTR dialing of directory zero. *
&M3	Select sync connect with async off-line command mode and enable DTR to act as Talk/Data switch. *
&P0	Set 10 pps pulse dial with 39%/61% make/break.
&P1	Set 10 pps pulse dial with 33%/67% make/break.
&P2	Set 20 pps pulse dial with 39%/61% make/break.
&P3	Set 20 pps pulse dial with 33%/67% make/break.
&Q0	Select direct asynchronous mode.
&Q1	Select sync connect with async off-line command mode. *
&Q2	Select sync connect with async off-line command mode and enable DTR dialing of directory zero. *
&Q3	Select sync connect with async off-line command mode and enable DTR to act as Talk/Data switch. *
&Q4	Select Hayes AutoSync mode.
&Q5	Modem negotiates an error corrected link.
&Q6	Select asynchronous operation in normal mode.
&R0	CTS tracks RTS (async) or acts per V.25 (sync).
&R1	CTS is always active.
&S0	DSR is always active.
&S1	DSR acts per V.25.
&T0	Terminate any test in progress.
&T1	Initiate local analog loopback.
&T2	Returns ERROR result code.
&T3	Initiate local digital loopback.
&T4	Allow remote digital loopback.
&T5	Disallow remote digital loopback request.
&T6	Request an RDL without self-test.
&T7	Request an RDL with self-test.
&T8	Initiate local analog loop with self-test.
&V	Display current configurations.
&V1	Display connection statistics
&W0	Store the active profile in NVRAM profile 0.
&W1	Store the active profile in NVRAM profile 1.
&X0	Select internal timing for the transmit clock.
&X1	Select external timing for the transmit clock.
&X2	Select slave receive timing for the transmit clock.
&Y0	Recall stored profile 0 upon power up.
&Y1	Recall stored profile 1 upon power up.
&Zn=x	Store dial string x (to 34) to location n (0 to 3).
%E0	Disable line quality monitor and auto retrain.
%E1	Enable line quality monitor and auto retrain.
%E2	Enable line quality monitor and fallback/fall forward.
%L	Return received line signal level.
%Q	Report the line signal quality.
%7	Plug and Play serial number
%8	Plug and Play vendor ID and product number

* Serial interface operation only.

AT Commands for Central Site Modems Reference Manual

\Kn	Controls break handling during three states: When modem receives a break from the DTE:
\K0,2,4	Enter on-line command mode, no break sent to the remote modem.
\K1	Clear buffers and send break to remote modem.
\K3	Send break to remote modem immediately.
\K5	Send break to remote modem in sequence with transmitted data.
	When modem receives \B in on-line command state:
\K0,1	Clear buffers and send break to remote modem.
\K2,3	Send break to remote modem immediately.
\K4,5	Send break to remote modem in sequence with transmitted data.
	When modem receives break from the remote modem:
\K0,1	Clear data buffers and send break to DTE.
\K2,3	Send a break immediately to DTE.
\K4,5	Send a break with received data to the DTE.
\N0	Select normal speed buffered mode.
\N1	Select direct mode.
\N2	Select reliable link mode.
\N3	Select auto reliable mode.
\N4	Force LAPM mode.
\N5	Force MNP mode.
\V0	Connect messages are controlled by the command settings X, W, and S95.
\V1	Connect messages are displayed in the single line format.
+MS	Select modulation.
+H0	Disable RPI/Video Ready Mode.
+H1	Enable RPI and set DTE speed to 19200 bps.
+H2	Enable RPI and set DTE speed to 38400 bps.
+H3	Enable RPI and set DTE speed to 57600 bps.
+H11	Enable RPI+ mode.
+H16	Enable Video Ready Mode
**0	Download to flash memory at last sensed speed.
**1	Download to flash memory at 38.4 kbps.
**2	Download to flash memory at 57.6 kbps.
-SDR=0	Disable Distinctive Ring.
-SDR=1	Enable Distinctive Ring Type 1.
-SDR=2	Enable Distinctive Ring Type 2.
-SDR=3	Enable Distinctive Ring Type 1 and 2.
-SDR=4	Enable Distinctive Ring Type 3.
-SDR=5	Enable Distinctive Ring Type 1 and 3.
-SDR=6	Enable Distinctive Ring Type 2 and 3.
-SDR=7	Enable Distinctive Ring Type 1, 2, and 3.

7.2 ECC COMMANDS

%C0	Disable data compression.
%C1	Enable MNP 5 data compression.
%C2	Enable V.42 bis data compression.
%C3	Enable both V.42 bis and MNP 5 compression.
\A0	Set maximum block size in MNP to 64.
\A1	Set maximum block size in MNP to 128.
\A2	Set maximum block size in MNP to 192.
\A3	Set maximum block size in MNP to 256.
\Bn	Send break of n x 100 ms.

AT Commands for Central Site Modems Reference Manual

7.3 MNP 10 COMMANDS

-K0	Disable MNP 10 extended services.
-K1	Enable MNP 10 extended services.
-K2	Enable MNP 10 extended services detection only.
-SEC=0	Disable MNP10-EC.
-SEC=1,[<tx level>]	Enable MNP10-EC and set transmit level <tx level> 0 to 30 (0 dBm to -30 dBm).

7.4 W-CLASS COMMANDS

*B	Display list of permanently blacklisted numbers.
*D	Display list of delayed numbers.
*NCn	Change country to one of eight in NVRAM.

7.5 CALLER ID COMMANDS

#CID=0	Disable Caller ID.
#CID=1	Enable Caller ID with formatted presentation.
#CID=2	Enable Caller ID with unformatted presentation.

7.6 FAX CLASS 1

+FCLASS=n	Service class.
+FAE=n	Data/fax auto answer
+FRH=n	Receive data with HDLC framing.
+FRM=n	Receive data.
+FRS=n	Receive silence.
+FTH=n	Transmit data with HDLC framing.
+FTM=n	Transmit data.
+FTS=n	Stop transmission and wait.

AT Commands for Central Site Modems Reference Manual

7.7 FAX CLASS 2

+FCLASS=n	Service class.
+FAA=n	Adaptive answer.
+FAXERR	Fax error value.
+FBOR	Phase C data bit order.
+FBUF?	Buffer size (read only).
+FCFR	Indicate confirmation to receive.
+FCLASS=	Service class.
+FCON	Facsimile connection response.
+FCIG	Set the polled station identification.
+FCIG:	Report the polled station identification.
+FCR	Capability to receive.
+FCR=	Capability to receive.
+FCSI:	Report the called station ID.
+FDCC=	DCE capabilities parameters.
+FDCS:	Report current session.
+FDCS=	Current session results.
+FDIS:	Report remote capabilities.
+FDIS=	Current sessions parameters.
+FDR	Begin or continue phase C receive data.
+FDT=	Data transmission.
+FDTC:	Report the polled station capabilities.
+FET:	Post page message response.
+FET=N	Transmit page punctuation.
+FHNG	Call termination with status.
+FK	Session termination.
+FLID=	Local ID string.
+FLPL	Document for polling.
+FMDL?	Identify model.
+FMFR?	Identify manufacturer.
+FPHCTO	Phase C time out.
+FPOLL	Indicates polling request.
+FPTS:	Page transfer status.
+FPTS=	Page transfer status.
+FREV?	Identify revision.
+FSPL	Enable polling
+FTSI:	Report the transmit station ID.

AT Commands for Central Site Modems Reference Manual

7.8 SYNCHRONOUS ACCESS MODE COMMANDS

+ES	Enables and disables Synchronous Access Mode in the client or central site modem
+ESA	Configures the operation of the Synchronous Access Submode
+ITF	Selects Transmit Flow Control Thresholds

7.9 CSM UNIQUE COMMANDS

+ISP	Selects Pass-Through Mode or POTS Modem Connection
+ES	Selects Frame Tunneling Mode
#CID	Enables and disables Multi-Frequency (MF) Tone Detection
+TSA	Program the Time Slot Assignment

8. COMMON CONFIGURATION SETUP STRINGS

This appendix describes setup strings to establish commonly used configurations.

1. Force V.42 bis data compression with LAP-M error correction.

AT+N4%C2-K0

2. Force V.42 bis data compression with MNP error correction.

AT+N5%C2

3. Force MNP 5 data compression with MNP error correction.

AT+N5%C1

Note: With the setup strings in examples 1-3, if the remote is unable to negotiate the desired rate mode, the modem will disconnect and respond with NO CARRIER.

4. Auto negotiate data compression and error correction.

AT&F (factory defaults) or

AT+N3%C3

In this mode, the modem prefers LAP-M over MNP 10, MNP 10 over MNP 4, and V.42 bis over MNP 5. If error correction is not negotiated, the modem will connect in normal mode.

AT Commands for Central Site Modems Reference Manual

This page is intentionally blank.

INSIDE BACK COVER NOTES

Headquarters

Rockwell Semiconductor Systems
4311 Jamboree Road,
P.O. Box C
Newport Beach, CA 92658-8902
Phone: (714) 221-4600
Fax: (714) 221-6375

European Headquarters

Rockwell Semiconductor Systems
S.A.R.L.
Les Talissounieres B1
Route des Dolines
Sophia Antipolis Cedex
06905 Valbonne
France
Phone: (33) 93 00 33 35
Fax: (33) 93 00 33 03

For more information:

Call 1-800-854-8099

International information:

Call 1-714-833-6996

URL Address:

<http://www.nb.rockwell.com>

E-Mail Address:

literature@nb.rockwell.com

REGIONAL SALES OFFICES

US Southwest Office

Rockwell Semiconductor Systems
5000 Birch Street
Suite 400
Newport Beach, CA 92660
Phone: (714) 222-9119
Fax: (714) 222-0620

US Southwest Satellite Office

Rockwell Semiconductor Systems
1000 Business Center Circle
Suite 215
Thousand Oaks, CA 91320
Phone: (805) 376-0559
Fax: (805) 376-8180

US South Central Office

Rockwell Semiconductor Systems
2001 North Collins Blvd
Suite 103
Richardson, TX 75080
Phone: (214) 379-9310
Fax: (214) 479-9317

US Southeast Office

Rockwell Semiconductor Systems
900 Ashwood Parkway
Suite 400
Atlanta, GA 30338
Phone: (770) 393-1830
Fax: (770) 395-1419

US Southeast Satellite Office

Rockwell Semiconductor Systems
One Prestige Place
2600 McCormick Drive
Suite 350
Clearwater, FL 34619
Phone: (813) 799-8406
Fax: (813) 799-8306

US Northwest Office

Rockwell Semiconductor Systems
US Northwest Office
3600 Pruneridge Avenue
Suite 100
Santa Clara, CA 95051
Phone: (408) 249-9696
Fax: (408) 249-7113

US North Central Office

Rockwell Semiconductor Systems
Two Pierce Place
Chancellory Park
Suite 810
Itasca, IL 60143
Phone: (630) 773-3454
Fax: (630) 773-3907

US Northeast Office

Rockwell Semiconductor Systems
239 Littleton Road
Suite 4A
Westford, MA 01886
Phone: (508) 692-7660
Fax: (508) 692-8185

Australia

Rockwell Semiconductor Systems
Rockwell Australia Pty Limited
Suite 603, 51 Rawson Street
Epping, NSW 2121
Australia
Phone: (61-2) 9869 4088
Fax: (61-2) 9869 4077

Europe Mediterranean

Rockwell Semiconductor Systems
c/o Rockwell Automation S.r.l.
Via Di Vittorio, 1
20017 Mazzo Di Rho (MI)
Italy
Phone: (39 2) 93179911
Fax: (39 2) 93179913

Europe North

Rockwell Semiconductor Systems, Ltd.
Berkshire Court
Western Road
Bracknell
Berkshire RG12 1RE
England
Phone: +44 1344 486 444
Fax: +44 1344 486 555

Europe South

Rockwell Semiconductor Systems
S.A.R.L.
Tour GAN
Cedex 13
92082 Paris La Defense 2
France
Phone: (33-1) 49-06-3980
Fax: (33-1) 49-06-3990

Germany

Rockwell Semiconductor Systems
Rockwell Int'l GmbH Germany
Paul-Gerhardt-Allee 50 a
81245 Munchen
Germany
Phone: (49-89) 829-1320
Fax: (49-89) 834-2734

Hong Kong

Rockwell Int'l (Asia Pacific) Ltd.
13th Floor, Suites 8-10,
Harbour Centre
25 Harbour Road
Wanchai,
Hong Kong
Phone: (852) 2 827-0181
Fax: (852) 2 827-6488

Japan

Rockwell Int'l Japan Co., Ltd.
Shimomoto Bldg
1-46-3 Hatsudai, Shibuya-ku
Tokyo, 151
Japan
Phone: (81-3) 5371 1520
Fax: (81-3) 5371 1501

Korea

Rockwell-Collins Int'l, Inc.
Room No. 1508
Korea Textile Centre Building
944-31, Daechi-3dong
Kangnam P.O. Box 2037
Kangnam-ku
Seoul
Korea
Phone: (82-2) 565-2880
Fax: (82-2) 565-1440

Singapore

Rockwell Semiconductor Systems
Singapore Branch
1 Kim Seng Promenade
#09-01 Great World City East Tower
Singapore 237994
Phone: (65) 737-7355
Fax: (65) 737-9077

Taiwan

Rockwell Int'l Taiwan Company, Ltd.
Room 2808 International Trade Bldg.
333, Keelung Road, Section I
Taipei,
Taiwan
10548 ROC
Phone: (886-2) 720-0282
Fax: (886-2) 757-6760

SOUND071697