

P87C591 Microcontroller

Program/Verify Specifications

1999 Jan 05



Table 1 PIN DESCRIPTION:PIN DESCRIPTION:

P L C C	Q F P	PIN NAME	NAME DURING PROG.	I/O	FUNCTION DURING PROGRAMMING
4	4				
4	4				
1	39	<u>AVSS</u>	<u>AVSS</u>		<u>Ground</u>
2	40	P1.0	A0	I	Address input 0
3	41	P1.1	A1	I	Address input 1
4	42	P1.2	A2	I	Address input 2
5	43	P1.3	A3	I	Address input 3
6	44	P1.4	A4	I	Address input 4
7	1	P1.5	A5	I	Address input 5
8	2	P1.6	A6	I	Address input 6
9	3	P1.7	A7	I	Address input 7
10	4	<u>RST</u>	<u>RST</u>	I	<u>Reset always connected LOW</u>
11	5	P3.0			
12	6	PWM0			
13	7	P3.1			
14	8	P3.2			
15	9	P3.3			
16	10	P3.4			
17	11	P3.5			
18	12	P3.6	P3.6	I	Mode select
19	13	P3.7	P3.7	I	Mode select
20	14	XTAL2	XTAL2	O	Clock out
21	15	XTAL1	XTAL1	I	Clock in
22	16	V _{SS}	V _{SS}	P	Ground
23	17	<u>V_{DD}</u>	<u>V_{DD}</u>	P	<u>+5V</u>
24	18	P2.0	A8	I	Address input 8
25	19	P2.1	A9	I	Address input 9
26	20	P2.2	A10	I	Address input 10
27	21	P2.3	A11	I	Address input 11
28	22	P2.4	A12	I	Address input 12
29	23	P2.5	A13	I	Address input 13
30	24	P2.6	P2.6	I	Mode select
31	25	P2.7	P2.7	I	Mode select
32	26	<u>PSEN</u>	<u>PSEN</u>	I	<u>PSEN always connected to Low</u>
33	27	<u>ALE</u>	<u>PROG</u>	I	<u>Five active Low Programming pulses</u>
34	28	PWM1			
35	29	<u>EA</u>	V _{PP} /V _{IH}		12.75V or 5V
36	30	P0.7	D7	I/O	Data
37	31	P0.6	D6	I/O	Data
38	32	P0.5	D5	I/O	Data
39	33	P0.4	D4	I/O	Data
40	34	P0.3	D3	I/O	Data
41	35	P0.2	D2	I/O	Data
42	36	P0.1	D1	I/O	Data
43	37	P0.0	D0	I/O	Data
44	38	<u>AV_{REF+}</u>	<u>AV_{REF+}</u>	P	<u>+5V</u>

Table 2 :Product ID

PRODUCT	EPROM SIZE	END ADDRESS	SIGNATURE BYTES			SECURITY BITS		
			30H	31H	60H	1	2	3
P87C591	16K x 8	3FFFH	15H	98H	01H	Y	Y	Y

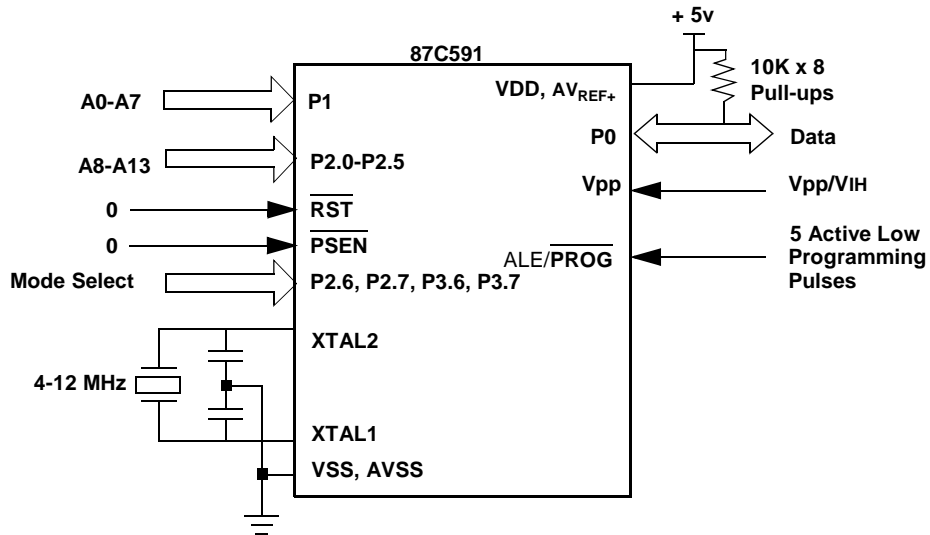

Figure 1. Programming/Verify connection

Note:

1. All address pins have to be driven, some P1 pins do not have pullups and should not be left open.

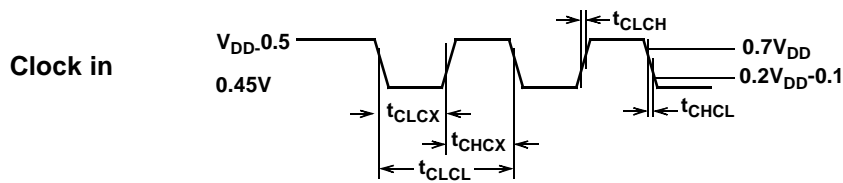

Figure 2. Clock Timing Waveform

Table 3 :Programming modes

MODE	$\overline{\text{RST}}$	$\overline{\text{PSEN}}$	ALE/ PROG	V _{PP}	MODE SELECT				ADDRESS A[13:0] INPUT	DATA D[7:0] I/O
					P2.7	P2.6	P3.7	P3.6		
Read Signature Byte 1	0	0	1	1	EV	0	0	0	30H	Sig.1 out
Read Signature Byte 2	0	0	1	1	EV	0	0	0	31H	Sig.2 out
Read Signature Byte 3	0	0	1	1	EV	0	0	0	60H	Sig.3 out
Program code	0	0	NP	V _{PP}	1	0	1	1	Byte Address	Byte Data In
Verify code	0	0	1	1	EV	0	1	1	Byte Address	Byte Data Out
Program Encryption byte	0	0	NP	V _{PP}	1	0	1	0	0 to 3FH	Byte Data In
Program Security bit 1	0	0	NP	V _{PP}	1	1	1	1	X	X
Program Security bit 2	0	0	NP	V _{PP}	1	1	0	0	X	X
Program Security bit 3	0	0	NP	V _{PP}	EV	1	0	1	X	X
Verify Security bits	0	0	1	1	EV	0	1	0	X	Data Out

Notes:

1. "0" = Valid V_{IL} "1" = Valid V_{IH}
2. V_{PP} = 12.75V ±0.25V
3. V_{DD} = 5V ±0.5V
4. NP = 5 Negative Pulses
5. $\overline{\text{EV}}$ = Enable Verify

Reading Signature bytes

The 3 signature bytes are assigned by Philips to uniquely identify each product. The signature bytes are read out of locations 030H, 031H and 060H. The signature bytes can only be verified, they cannot be programmed by the programmer.

1. Connect V_{DD} = 5V, V_{PP} = 5V, Connect a crystal to pins XTAL1 and XTAL2 or a clock to XTAL1 pin.
2. Connect the mode select inputs as specified in Table 3 for reading signature bytes.
3. Apply Address = 30H; toggle P2.7 from 1 to 0, to enable verify; wait 24 clock cycles (minimum) and read the signature byte on port 0.
4. Repeat reading from address 31H and 60H.

Verify EPROM

1. Connect V_{DD} = 5V, V_{PP} = 5V, Connect a crystal to pins XTAL1 and XTAL2 or a clock to XTAL1 pin.
2. Connect the mode select inputs as specified at Table 3 for code verify.
3. Apply Address = 0H; toggle P2.7 from 1 to 0, to enable verify; wait 24 clock cycles (minimum) and read the code byte on port 0.

4. Repeat reading through all the Program addresses.

EPROM Programming

1. Connect $V_{DD} = 5V$, $V_{PP} = 5V$, Connect a crystal to pins XTAL1 and XTAL2 or a clock to XTAL1 pin.
2. Connect the mode select inputs as specified at Table 3 for programming code and $\overline{PROG}=1$.
3. Wait 10 μ Sec and change $V_{PP} = 5V$ to $V_{PP} = 12.75V$
4. Apply Address and data of the programmed byte, wait 24 clock cycles (minimum).
5. Generate five active low pulses on pin \overline{PROG} to program the byte.
6. Apply Address and data of the next programmed byte, wait 24 clock cycles (minimum).
7. Generate five active low pulses on pin \overline{PROG} to program the byte.
8. repeat 6,7 for all the programmed bytes.
9. Wait 10 μ Sec and change $V_{PP} = 12.75V$ to $V_{PP} = 5V$

Encryption Table Programming

The 87C591 has a 64 byte encryption table.

1. Connect $V_{DD} = 5V$, $V_{PP} = 5V$, Connect a crystal to pins XTAL1 and XTAL2 or a clock to XTAL1 pin.
2. Connect the mode select inputs as specified at Table 3 for Encryption Table programming and $\overline{PROG}=1$.
3. Wait 10 μ Sec and change $V_{PP} = 5V$ to $V_{PP} = 12.75V$
4. Apply Address and data of the programmed byte, wait 24 clock cycles (minimum).
5. Generate five active low pulses on pin \overline{PROG} to program the byte.
6. Apply Address and data of the next programmed byte, wait 24 clock cycles (minimum).
7. Generate five active low pulses on pin \overline{PROG} to program the byte.
8. repeat 6,7 for all the Encryption Table bytes.
9. Wait 10 μ Sec and change V_{PP} from 12.75V to 5V

Security bits Programming

1. Connect $V_{DD} = 5V$, $V_{PP} = 5V$, Connect a crystal to pins XTAL1 and XTAL2 or a clock to XTAL1 pin.
2. Connect the mode select inputs as specified at Table 3 for Security bits programming and $\overline{PROG}=1$.
3. Wait 10 μ Sec and change $V_{PP} = 5V$ to $V_{PP} = 12.75V$
4. Wait 24 clock cycles (minimum).
5. Wait 10 μ Sec and change V_{PP} from 12.75V to 5V
6. Repeat 2-5 for all the security bits.

Verify Security bits

1. Connect $V_{DD} = 5V$, $V_{PP} = 5V$, Connect a crystal to pins XTAL1 and XTAL2 or a clock to XTAL1 pin.
2. Connect the mode select inputs as specified at Table 3 for security bits verify.
3. Toggle P2.7 from 1 to 0, to enable verify; wait 24 clock cycles (minimum) and read the byte on port 0.

Table 4 :Security Bits

PORT 0	SECURITY BITS
P0.7 = 0	Security bit 1 programmed
P0.7 = 1	Security bit 1 not programmed
P0.6 = 0	Security bit 2 programmed
P0.6 = 1	Security bit 2 not programmed
P0.3 = 0	Security bit 3 programmed
P0.3 = 1	Security bit 3 not programmed
P0.5 = 0	This bit is always = 0

Table 5DC Characteristics

DC CHARACTERISTIC $T_A = 0^{\circ}\text{C}$ to 70°C , $V_{DD} = 5V \pm 5\%$, $V_{PP} = 12.75V \pm 0.25V$

SYMBOL	PARAMETER	MIN	TYP	MAX	UNIT	NOTES
IDD	VDD current		20	45	mA	
IPP	VPP current			50	mA	
VIL	Input Low Voltage	-0.5		$.2 \cdot V_{DD} - 0.1$	V	Except P1.0, P1.1, P1.6, P1.7
VIL1	Input Low Voltage	-0.5		$.2 \cdot V_{DD} - 0.3$	V	for \overline{EA}
VIL2	Input Low Voltage	-0.5		1.4	V	P1.0 and P1.1
VIL3	Input Low Voltage	-0.5		$.3 \cdot V_{DD}$	V	P1.6 and P1.7
VIH	Input High Voltage	$.2V_{DD} + .9$		$V_{DD} + 0.5V$	V	Except P1.0, P1.1, P1.6, P1.7, XTAL1, \overline{RST}
VIH1	Input High Voltage	$.7V_{DD}$		$V_{DD} + 0.5V$	V	XTAL1, \overline{RST}
VIH2	Input High Voltage	3		$V_{DD} + 0.5V$	V	P1.0, P1.1
VIH3	Input High Voltage	$.7V_{DD}$		6V	V	P1.6, P1.7

NOTES:

1. V_{DD} must be applied before V_{PP} and removed after V_{PP} .
2. V_{PP} must not exceed 13V including overshoot.
3. V_{IH} is for pins P0, P1, P2, P3, \overline{EA}
4. V_{IH1} is for pins XTAL1, \overline{RST}

Table 6 - AC Characteristics for P87C591

AC CHARACTERISTIC TA = 0°C to 70 °C, VDD = 5V ± 5%, VPP = 12.75V ± 0.25V

SYMBOL	PARAMETER	MIN	MAX	UNIT
1/tCLCL	Oscillator/Clock frequency	3.5	12	MHz
tCHCX	XTAL1 CLK High	20		nSec
tCLCX	XTAL1 CLK Low	20		nSec
tCLCH	XTAL1 CLK rise time		20	nSec
tCHCL	XTAL1 CLK fall time		20	nSec
tAVGL	Address setup to PROG Low	24*tCLCL		
tGHAX	Address hold after PROG change	24*tCLCL		
tDVGL	Data setup to PROG Low	24*tCLCL		
tGHDX	Data hold after PROG change	24*tCLCL		
tEHS	P2.7 (ENABLE) High to VPP High	24*tCLCL		
tSHGL	VPP setup to PROG Low	10		µSec
tGHSL	VPP hold after PROG	10		µSec
tGLGH	PROG pulse width	40	60	µSec
tAVQV	Address to Valid data	7*tCLCL	24*tCLCL	
tELQV	P2.7 (ENABLE) Low to valid data	18*tCLCL	24*tCLCL	
tEHQZ	Data float after P2.7 (ENABLE) High	18*tCLCL	24*tCLCL	
tGHGL	PROG High to PROG Low	10		µSec

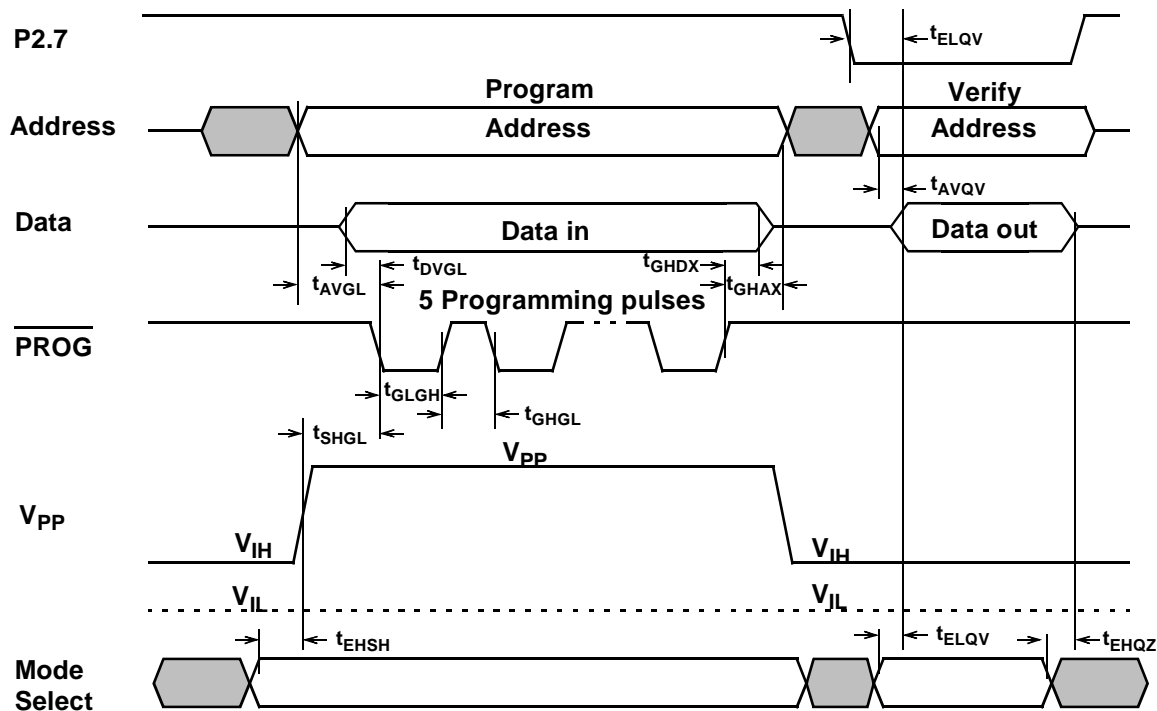

Figure 3. Program/Verify Timings

Single-chip 8-bit microcontroller with CAN controller

P8xC591

6 PINNING INFORMATION

6.1 Pinning diagram

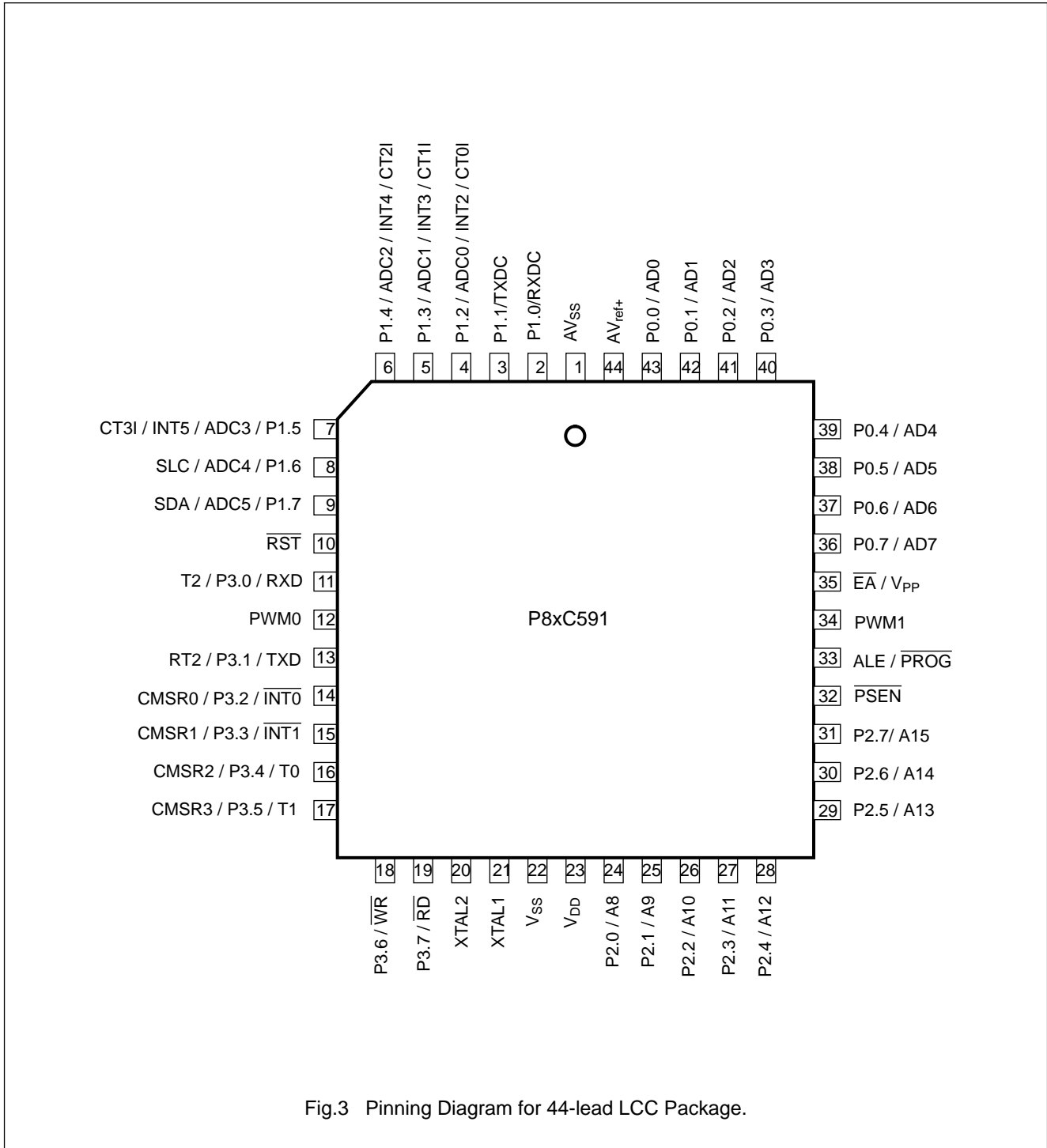
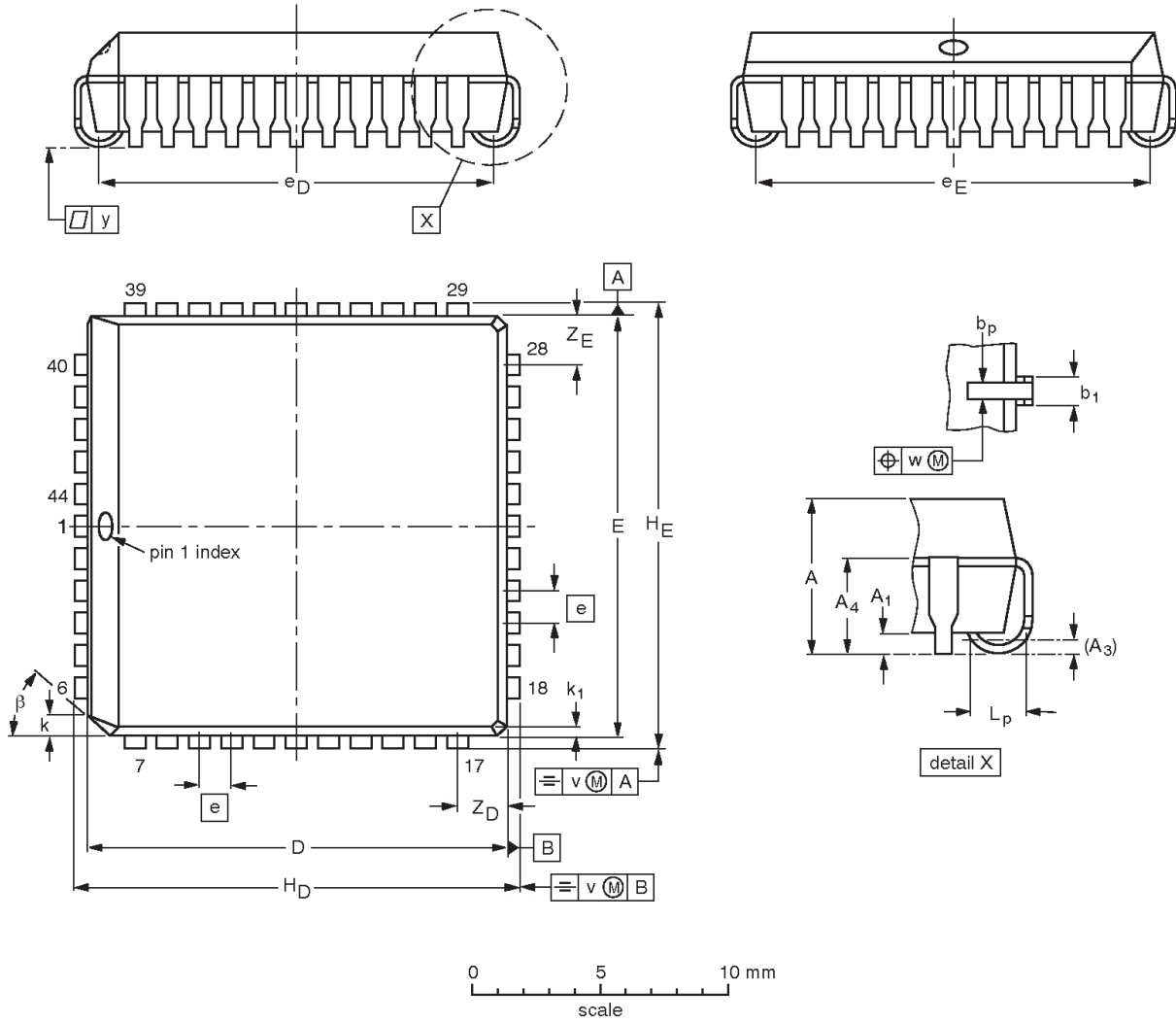

Fig.3 Pinning Diagram for 44-lead LCC Package.

Package outlines

PLCC44: plastic leaded chip carrier; 44 leads

SOT187-2



DIMENSIONS (millimetre dimensions are derived from the original inch dimensions)

UNIT	A	A ₁ min.	A ₃	A ₄ max.	b _p	b ₁	D ⁽¹⁾	E ⁽¹⁾	e	e _D	e _E	H _D	H _E	k	k ₁ max.	L _p	v	w	y	Z _D ⁽¹⁾ max.	Z _E ⁽¹⁾ max.	β
mm	4.57 4.19	0.51	0.25	3.05	0.53 0.33	0.81 0.66	16.66 16.51	16.66 16.51	1.27	16.00 14.99	16.00 14.99	17.65 17.40	17.65 17.40	1.22 1.07	0.51	1.44 1.02	0.18	0.18	0.10	2.16	2.16	45°
inches	0.180 0.165	0.020	0.01	0.12	0.021 0.013	0.032 0.026	0.656 0.650	0.656 0.650	0.05	0.630 0.590	0.630 0.590	0.695 0.685	0.695 0.685	0.048 0.042	0.020	0.057 0.040	0.007	0.007	0.004	0.085	0.085	

Note

1. Plastic or metal protrusions of 0.01 inches maximum per side are not included.

OUTLINE VERSION	REFERENCES				EUROPEAN PROJECTION	ISSUE DATE
	IEC	JEDEC	EIAJ			
SOT187-2	112E10	MO-047AC				95-02-25 97-12-16

Single-chip 8-bit microcontroller with CAN controller

P8xC591

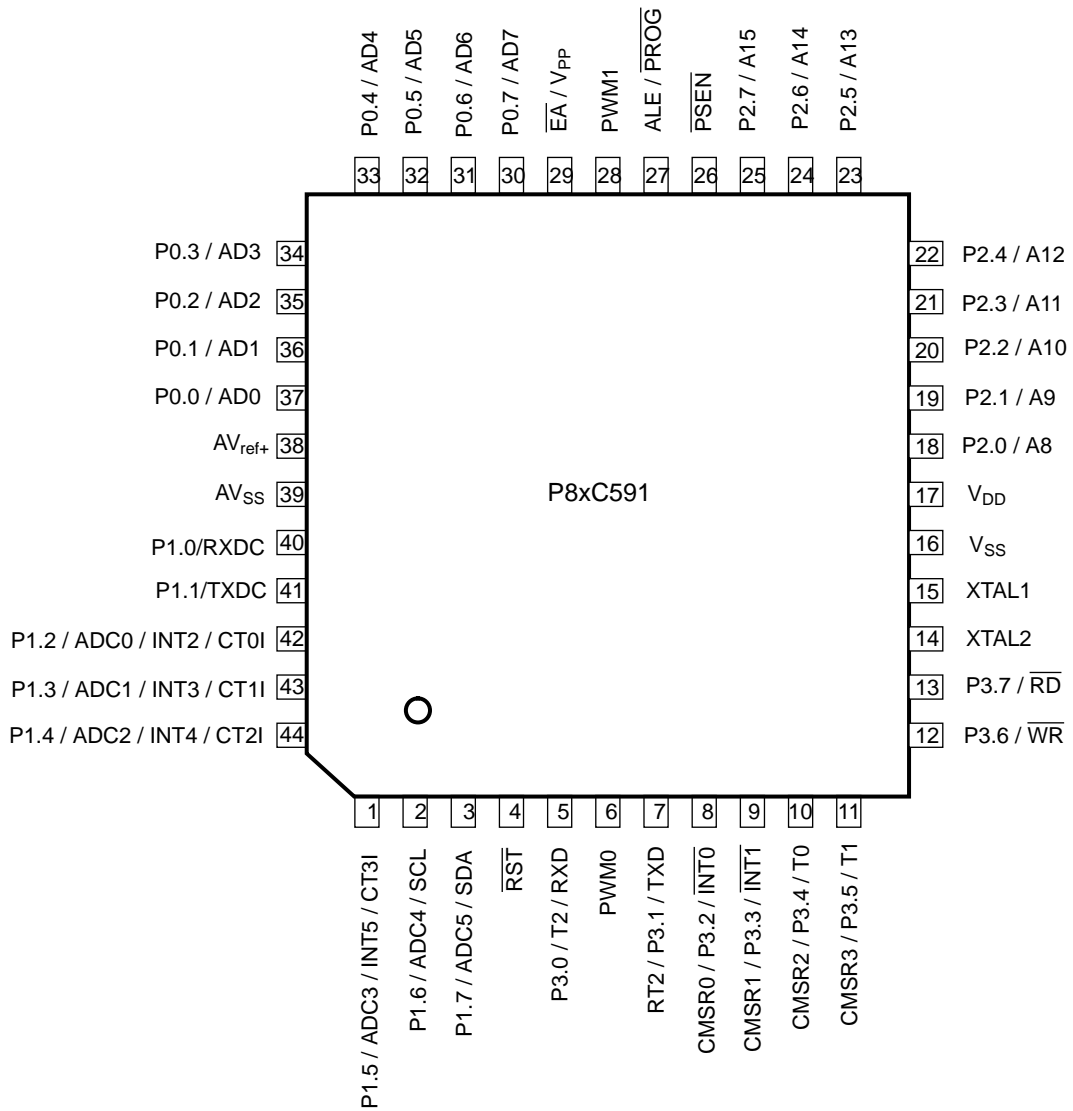
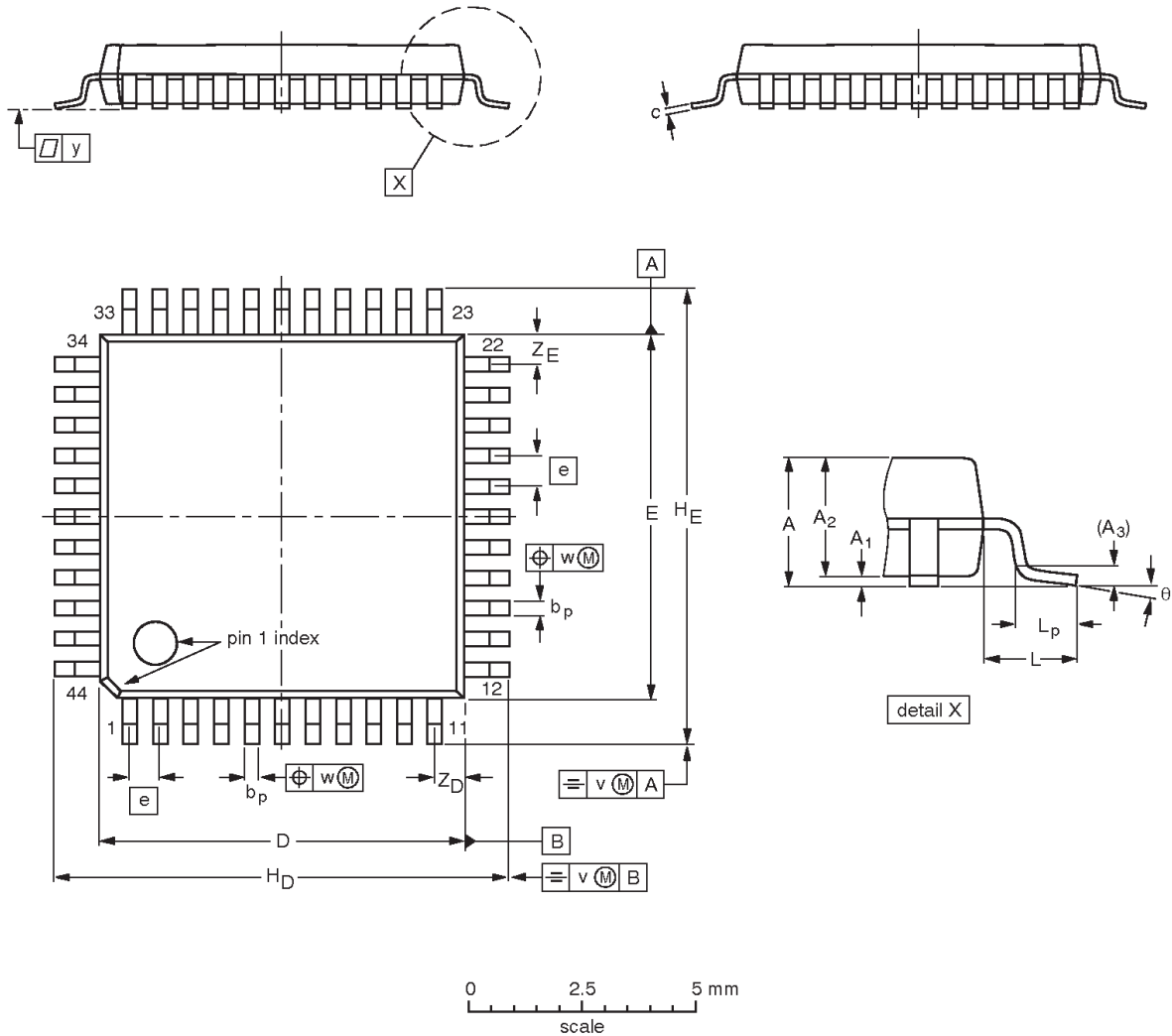

Fig.4 Pinning Diagram for 44-lead Plastic Quad Flat Package (QFP).

Package outlines

QFP44: plastic quad flat package; 44 leads (lead length 1.3 mm); body 10 x 10 x 1.75 mm

SOT307-2



DIMENSIONS (mm are the original dimensions)

UNIT	A _{max.}	A ₁	A ₂	A ₃	b _p	c	D ⁽¹⁾	E ⁽¹⁾	e	H _D	H _E	L	L _p	v	w	y	Z _D ⁽¹⁾	Z _E ⁽¹⁾	θ
mm	2.10	0.25 0.05	1.85 1.65	0.25	0.40 0.20	0.25 0.14	10.1 9.9	10.1 9.9	0.8	12.9 12.3	12.9 12.3	1.3	0.95 0.55	0.15	0.15	0.1	1.2 0.8	1.2 0.8	10° 0°

Note

1. Plastic or metal protrusions of 0.25 mm maximum per side are not included.

OUTLINE VERSION	REFERENCES				EUROPEAN PROJECTION	ISSUE DATE
	IEC	JEDEC	EIAJ			
SOT307-2						95-02-04 97-08-01